

Dimension[®] Xpand[®] Plus Instrument Specifications

Effective: November 2008

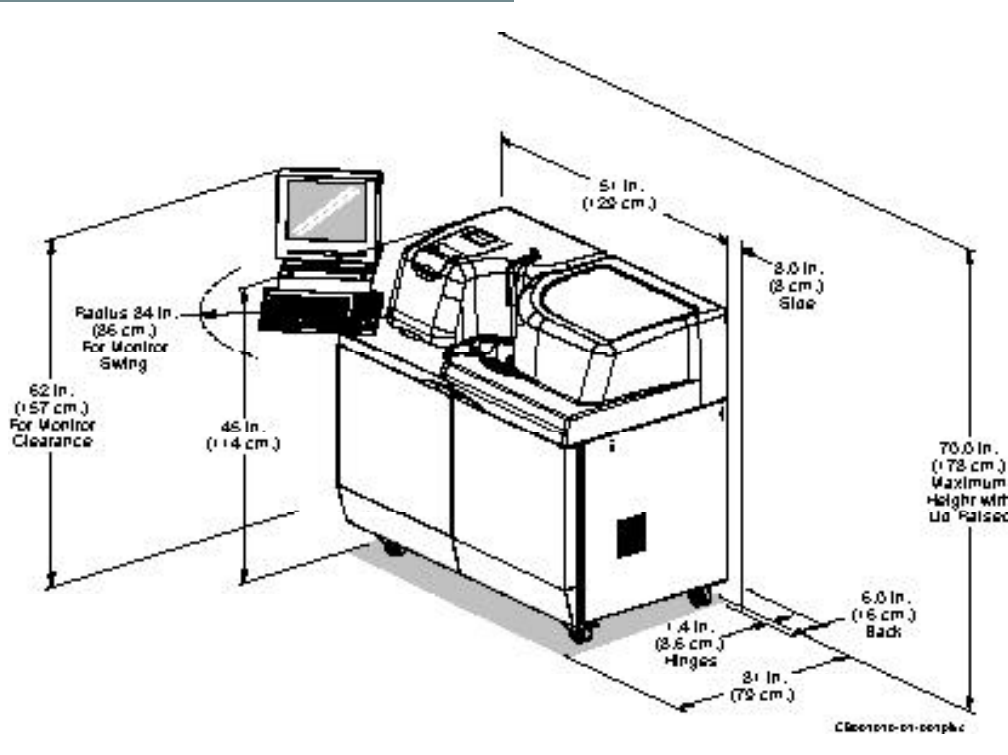

Instrument Weight and Dimensions

Weight

765 lb (348 kg) Basic

783 lb (356 kg) with Heterogeneous Immunoassay (HM) Module

Dimensions

51 in. wide x 45 in. high (without monitor) x 31 in. deep
(129 cm w x 114 cm h x 79 cm d)

Additional Instrument Clearances (Minimum)

- Monitor overhead clearance—62 in. (157 cm)
- Monitor left side clearance—34 in. (86 cm)
- Raised instrument lids clearance—70 in. (178 cm)
- Cooling fan clearance on right side—3 in. (8 cm)
- Ventilation clearance in back—6 in. (16 cm)
- Doorway opening for installation—32 in. (81 cm)

Notes: No leveling required; however, the two front casters should be locked during system operation.

A 360° access is needed for service. Installation and service require at least 36 in. (91 cm) of working space on each side. Access to the back of the instrument requires moving it forward.

Room Environment

Operating Temperature

Room temperature must be 65–85°F (17–30°C) with a maximum fluctuation of 5°F (2.8°C) per hour. The system requires a maximum of 120 minutes to warm up from a cold start to the incubation temperature.

Relative Humidity

Maintain between 20% and 80%

Average Thermal Output

3753 BTU/hr (1100 W)

Average Noise Output

<70 dBA at 1 m while operating

Water Requirements

- Instrument feed water: must maintain stable dO₂ content between 5 and 8 ppm
- Consumption 0.53 gal/hr (2.0 L/hr) at maximum throughput
- Temperature: < 35°C
- Resistivity: ≥ 10 megohms cm
- Bacterial content: ≤ 10 colony-forming units/mL
- System feed water line must not exceed 12 feet
- System is supplied with water system

Waste Requirements

Liquid Waste Output

0.53 gal/hr (2.0 L/hr) at maximum throughput

A 50-ft (15.2-m) tubing is supplied for external waste disposal. Maintenance of the waste tubing from the instrument to the disposal point is the responsibility of the user. The disposal point should be selected in accordance with local hazardous waste guidelines.

Electrical Installation Requirements

Current/Operating Power Requirements

	Nominal Line Voltage vac	Line Voltage range vac	Nominal Line Frequency Hz	Maximum Continuous Current, AMPS	Power Consumption WATTS
Xpand® Plus system	115	103 to 127	47 to 63	~10	1150
	230	207 to 253	47 to 63	~5.0	1150
Xpand® Plus system with HM	115	103 to 127	47 to 63	~11	1265
	230	207 to 253	47 to 63	~5.5	1265

Recommended Service Outlet

115 vac, 60Hz, Single Phase, 20A (North America)
230 vac, 50Hz, Single Phase, 16A (EU)*
*230 VAC/13A for U.K.

Transient Overvoltage

Installation Category II (branch circuit)

Circuit

The instrument must have a separate, dedicated line with Hot, Neutral, and Isolated Ground in its own conduit. The conduit should start at the distribution panel and be continuous to the receptacle. Three-wire distribution to the receptacle is required for each instrument. The third (green) ground wire should start at the distribution panel and be continuous to the receptacle in accordance with NEC paragraph 250.146(d) unless local codes prohibit. The ground wire should not be tied grounds from other loads.

Leakage Current

	115 vac/60 Hz	230 vac/50 Hz
Normal Supply Connections	Under 10 µA	Under 100 µA
Ground Disconnected	Under 70 µA	Under 150 µA
Measurement Standard	UL3101-1	EN61010-1

This complies with the requirement of UL 3101-1, CSA C22.2 #1010.1 and TUVS Certification for EN61010-1 safety standards for laboratory equipment in non-patient-vicinity laboratory equipment.

Wire Size (North America only)

10 AWG wire is required to minimize voltage drop between the distribution panel and the receptacle when the instrument operates at full current load.

Receptacle

Customer must provide a Hospital Grade receptacle, installed by a qualified electrician before arrival of the instrument. The receptacle must be accessible to the 9-ft (2.7-m) power cord furnished with the instrument. The U. S. A. requires NEMA #5-20R 20 amp straight blade receptacle (Hubbell receptacle No. IG-8310 or equivalent).

Electromagnetic Radiation

Do not locate the instrument within 50 ft (15 m) in any direction of an electromagnetic radiation source such as diathermy apparatus.

Phone Line Requirement

A dedicated phone line connected to the Dimension® Xpand® Plus system is required for installation.

- Dedicated, direct line connected only to the Dimension® Xpand® Plus system (not through a switchboard)
- Full duplex, capable of two-way transmission
- Standard phone connection (not digital)
- RJ11C or RJ11W phone jack

Host Interfacing

A 25-pin female connector is required for hookup to the male connector used for host communications port.

Installation

The Dimension® Xpand® Plus clinical chemistry system will be installed by a qualified representative of Siemens Healthcare Diagnostics Inc. The installation will include checkout of all aspects necessary to ensure the equipment is fully operational.

Preventive Maintenance Frequency

Four Siemens service preventive maintenance visits per year for the Dimension® Xpand® Plus system with HM.

Three Siemens service preventive maintenance visits per year for the Dimension® Xpand® Plus system without HM.

Code Compliance

Safety Compliance

The Dimension® Xpand® Plus system has been designed and tested to comply with safety standards UL3101-1, CSA C22.2 #1010.1 and EN61010-1 under the following environmental conditions [subclause 1.4]:

Temperature	5°C (41°F) to 40°C (104°F)
Humidity	Maximum 80% at 31°C to 50% at 40°C
Altitude	Maximum 2,000 m (6,562 ft)
Main Supply	115±10% vac or 230±10% vac, 50/60Hz
Overvoltage Category	Category II, connected to a branch circuit
Pollution degree	Degree 2, normal indoor laboratory environment. Air contains only non-conductive pollutants with occasional condensation.

Additional *functional* environmental conditions are discussed earlier in this document.

Emission Compliance

The Dimension® Xpand® Plus system has been designed and tested to EN55022 Class A. In a domestic environment it may cause radio interference, in which case you may need to take measures to mitigate the interference.

The Dimension® Xpand® Plus system should not be used next to any Industrial Scientific and Medical (ISM) equipment that must functionally produce RF energy (e. g., diathermy equipment).

Barcode Scanner

The barcode scanner uses Class I LEDs (light-emitting diodes) and is not hazardous to your eyes.