

SIEMENS

AXIOM Sensis 2.1 VC01B

AX

DICOM Conformance Statement

Rev. 03 4-Feb-05

© Siemens AG 2004
All rights reserved

Siemens AG, Medical Solutions,
Siemensstr. 1, D-91301 Forchheim, Germany

Headquarters: Berlin and Munich
Siemens AG, Wittelsbacher Platz 2, D-80333 Munich, Germany

Printed in the Federal Republic of Germany
Release 01

Table of Contents

Network Conformance Statement	5
1 Introduction	5
1.1 Overview	5
1.2 Scope and Field	5
1.3 Audience.....	5
1.4 Remarks.....	5
1.5 Definitions, Terms and Abbreviations	7
1.6 References.....	7
1.7 Structure	7
2 Implementation Model Verification	8
2.1 Application Data Flow Diagram	8
2.2 Functional Definitions of Applications	8
2.3 Sequencing of Real-World Activities	8
3 Application Entity Specification Verification	9
3.1 Verification AE Specification	9
3.1.1 Association Establishment Policies	9
3.1.2 Association Initiation Policy	9
3.1.3 Association Acceptance Policy.....	10
4 Implementation Model Storage	11
4.1 Application Data Flow Diagram	11
4.2 Functional Definitions of Application Entities	11
4.3 Sequencing of Real-World Activities	11
5 Application Entity Specification Storage	12
5.1 Storage AEs Specification	12
5.1.1 Association Establishment Policies	12
5.1.2 Association Initiation Policy	13
5.1.3 Association Acceptance Policy.....	16
6 Implementation Model Storage Commitment	20
6.1 Application Data Flow Diagram	20
6.2 Functional Definitions of Application Entities	20
6.3 Sequencing of real World Activities.....	21
7 AE Specification Storage Commitment	22

7.1	Storage Commitment AE Specification	22
7.1.1	Association Establishment Policies	22
7.1.2	Association Initiation Policy	22
7.1.3	Association Acceptance Policy.....	24
8	Implementation Model Query / Retrieve	27
8.1	Application Data Flow Diagram	27
8.2	Functional Definitions of Application Entities	28
8.3	Sequencing of Real-World Activities	28
9	Application Entity Specification Query/Retrieve	29
9.1	Query/Retrieve Service AEs Specification	29
9.1.1	Association Establishment Policies	30
9.1.2	Association Initiation Policy	30
9.1.3	Association Acceptance Policy.....	34
10	Implementation Model Worklist.....	42
10.1	Application Data Flow Diagram	42
10.2	Functional Definitions of Application Entities	42
10.3	Sequencing of Real-World Activities	42
11	Application Entity Specification Worklist.....	43
11.1	Modality Worklist Service AE Specification	43
11.1.1	Association Establishment Policies	43
11.1.2	Association Initiation Policy	44
12	Communication Profiles.....	49
12.1	Supported Communication Stacks	49
12.1.1	OSI Stack.....	49
12.1.2	TCP/IP Stack	49
12.1.3	Point-to-Point Stack.....	49
13	Extensions / Specializations / Privatizations.....	50
13.1.1	Standard Extended / Specialized / Private SOPs.....	50
13.1.2	Private Transfer Syntaxes	50
14	Configuration	50
14.1	AE Title/Presentation Address Mapping.....	50
14.1.1	DICOM Verification	50
14.1.2	DICOM Storage AE Title	50
14.1.3	DICOM Query/Retrieve AE Title.....	50
14.1.4	DICOM Modality Worklist AE Title.....	50
14.2	Configurable Parameters	51
14.2.1	Storage and Query/Retrieve.....	51
14.2.2	Worklist	51
14.3	Default Parameters	51
15	Support of Extended Character Sets	52
Application Profile Conformance Statement.....		54
16	Introduction.....	55
16.1	Purpose.....	55

16.2	Scope	55
16.3	Definitions, Abbreviations	55
16.3.1	Definitions	55
16.3.2	Abbreviations	55
16.4	References.....	56
16.5	Remarks.....	56
17	<i>Implementation Model.....</i>	57
17.1	Application Data Flow Diagram	57
17.2	Functional Definitions of AEs	57
17.3	Sequencing of Real-World Activities	57
17.4	File Meta Information Options	58
18	<i>AE Specifications</i>	58
18.1	DICOM Archive Specification	58
18.1.1	File Meta Information for the Application Entity	58
18.1.2	Real-World Activities for this Application Entity	58
19	<i>Augmented and Private Profiles.....</i>	60
19.1	Augmented Application Profiles	60
19.1.1	AUG-XA1K-CD	60
19.2	Private Application Profiles	60
19.2.1	PRI-XAMAS-CD.....	60
20	<i>Extensions, Specializations and Privatizations of SOP Classes and Transfer Syntaxes</i>	60
20.1	Physical Media and Formats.....	60
20.2	Directory Information in DICOMDIR	61
20.2.1	Additional Keys	61
20.2.2	Private Directory Record Keys	62
20.2.3	Icon Images	62
20.3	SOP Specific Conformance Statement for Basic Directory.....	62
20.3.1	Extension, Specialization for SIEMENS Non-Image Objects.....	62
21	<i>Configuration</i>	63
21.1	AE Title Mapping.....	63
21.1.1	DICOM Media Storage AE Title.....	63
22	<i>Support of Extended Character Sets</i>	63
<i>Annex A: IOD descriptions</i>		64

Network Conformance Statement

1 Introduction

1.1 Overview

This Conformance Statement describes the DICOM interface for the Siemens AXIOM Sensis VC01A in terms of part 2 of [DICOM].

1.2 Scope and Field

The Siemens product AXIOM Sensis is a Cardiac Interventional System for Acquisition and Viewing of Waveform data during a catheterization procedure. The AXIOM Sensis is designed for integration into an environment of medical DICOM-based devices. AXIOM Sensis supports the storage of waveforms and images utilizing the DICOM "Storage Service Class" as SCU and SCP. The retrieval of Images from a PACS System utilizing the DICOM "Query/Retrieve Service Class" as an SCU is supported as well as SCP to support other systems that want to browse the contents of the Sensis database and retrieve images and waveforms from it. The primary purpose for supporting DICOM image storage in AXIOM Sensis is for the ability to include images in the reports. Clinical reports can also be converted to DICOM XA multiframe images to be sent over the network or stored on media. No image viewing, nor viewing of foreign DICOM waveform objects is supported in this release. The "Modality Worklist Service" is supported to minimize patient data input during Patient Registration. Furthermore the handling of CD offline media is supported as a FSC, FSU and FSR.

1.3 Audience

This document is intended for hospital staff, health system integrators, software designers or implementers. It is assumed that the reader has a working understanding of DICOM.

1.4 Remarks

DICOM, by itself, does not guarantee interoperability. However, the Conformance Statement facilitates a first-level validation for interoperability between different applications supporting the same DICOM functionality as SCU and SCP, respectively.

This Conformance Statement is not intended to replace validation with other DICOM equipment to ensure proper exchange of information intended.

The scope of this Conformance Statement is to facilitate communication with Siemens and other vendors' Medical equipment. The Conformance Statement should be read and understood in conjunction with the DICOM 3.0 Standard [DICOM]. However, by itself it is not guaranteed to ensure the desired interoperability and a successful interconnectivity.

Since AXIOM Sensis handles images, waveforms and Siemens private non-image objects, sometimes "object" or "instance" are used as the terms for all information carriers on "image" level.

The user should be aware of the following important issues:

- The comparison of different conformance statements is the first step towards assessing interconnectivity between Siemens and non-Siemens equipment.
- Test procedures should be defined and tests should be performed by the user to validate the connectivity desired. DICOM itself and the conformance parts do not specify this.
- The standard will evolve to meet the users' future requirements. Siemens is actively involved in developing the standard further and therefore reserves the right to make changes to its products or to discontinue its delivery.
- Siemens reserves the right to modify the design and specifications contained herein without prior notice. Please contact your local Siemens representative for the most recent product information.

1.5 Definitions, Terms and Abbreviations

Definitions, terms and abbreviations used in this document are defined within the different parts of the DICOM standard.

Additional Abbreviations and terms are as follows:

ACR	American College of Radiology
AE	DICOM Application Entity
ASCII	American Standard Code for Information Interchange
CSE	Customer Service Engineer
DB	Database
DCS	DICOM Conformance Statement
DSA	Digital Subtraction Angiography
IOD	DICOM Information Object Definition
ISO	International Standard Organization
NEMA	National Electrical Manufacturers Association
O	Optional Key Attribute
R	Required Key Attribute
RIS/HIS	Radiology Information System/Hospital Information System
PDU	DICOM Protocol Data Unit
RWA	Real-World Activity
SCU	DICOM Service Class User (DICOM client)
SCP	DICOM Service Class Provider (DICOM server)
SOP	DICOM Service-Object Pair
U	Unique Key Attribute
UI	User Interface

1.6 References

[DICOM] Digital Imaging and Communications in Medicine (DICOM), NEMA PS 3.1-3.14, 1999

1.7 Structure

The AXIOM Sensis Conformance Statement is subdivided into three Parts, which relate to individual documents needed to declare Conformance according to the requirements of "Part 2 - Conformance" of the DICOM Standard.

Those parts are:

- The "DICOM Conformance Statement" for Network related Services
- A privately defined "Application Profile"
- The "Offline Media Conformance Statement" to support local archive media.
- A general Appendix.

2 Implementation Model Verification

The Siemens AXIOM Sensis DICOM Service Tool application requests Verification to verify the ability of a foreign DICOM application on a remote node to respond to DICOM messages.

Responding to Verification requests from remote nodes is handled by the Storage SCP application.

2.1 Application Data Flow Diagram

The AXIOM Sensis DICOM network implementation is a Windows 2000 application and acts as SCU for the C-ECHO DICOM network service.

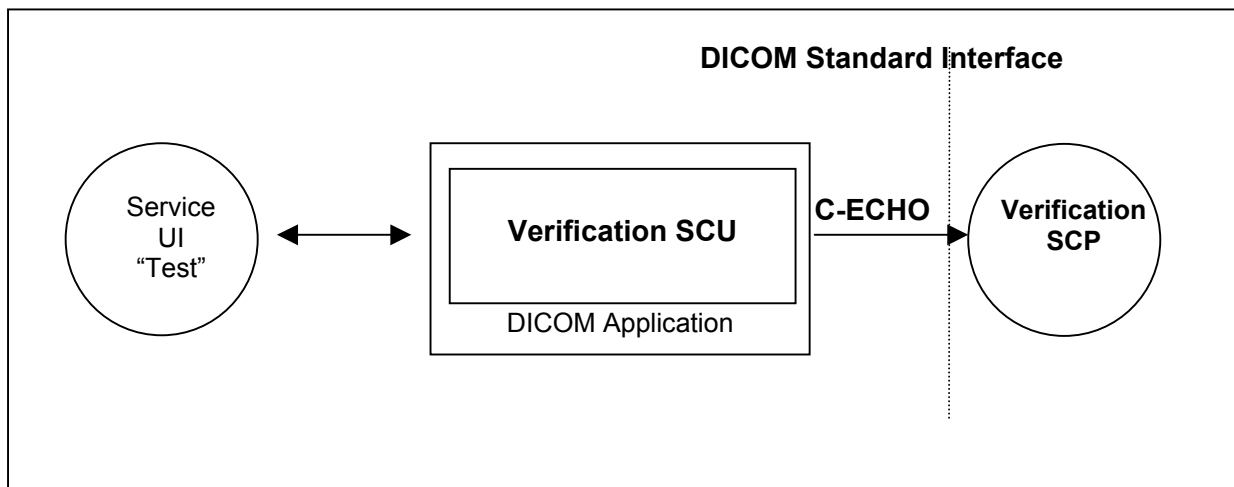

Figure 1: AXIOM Sensis Application Flow Diagram - Verification SCU

2.2 Functional Definitions of Applications

The AXIOM Sensis DICOM Service Tool application opens an association when a "Test" of a remote application is requested during a configuration session. This can be done when entering new data for remote application configuration or to verify existing configuration data.

2.3 Sequencing of Real-World Activities

Not applicable

3 Application Entity Specification Verification

3.1 Verification AE Specification

3.1.1 Association Establishment Policies

3.1.1.1 General

The AXIOM Sensis DICOM Service Tool application attempts to open an association for verification request whenever the "Test" function is activated during network configuration of a remote DICOM application.

3.1.1.2 Number of Associations

The AXIOM Sensis DICOM Service Tool application initiates one association at a time to request verification.

3.1.1.3 Asynchronous Nature

The AXIOM Sensis DICOM software does not support asynchronous communication (multiple outstanding transactions over a single association).

3.1.1.4 Implementation Identifying Information

Implementation Class UID	1.3.12.2.1107.5.9.20000101
Implementation Version Name	"SIEMENS_SWFVC10E"

3.1.2 Association Initiation Policy

The AXIOM Sensis DICOM Service Tool application attempts to initiate a new association for

- DIMSE C-ECHO service operations.

3.1.2.1 Associated Real-World Activity

3.1.2.1.1 Associated Real-World Activity – Request Verification

The associated Real-World activity is a C-ECHO request initiated by Service and Configuration SW environment whenever a "Test" is requested. If an association to a remote Application Entity is successfully established, Verification with the configured AET is requested via the open association. If the C-ECHO Response from the remote Application contains a status other than "Success" this will be indicated in the service environment and the association is closed.

3.1.2.1.2 Proposed Presentation Contexts

The AXIOM Sensis DICOM application will propose Presentation Contexts as shown in the following table:

Presentation Context Table – Verification SCU					
Abstract Syntax		Transfer Syntax		Role	Extended Negotiation
Name	UID	Name List	UID List		
Verification	1.2.840.10008.1.1	Implicit VR Little Endian	1.2.840.10008.1.2	SCU	None

3.1.2.1.3 SOP Specific Conformance – Verification SCU

None.

3.1.3 Association Acceptance Policy

The Verification SCP is part of the Storage SCP – see section 5.1.3.

4 Implementation Model Storage

The Siemens AXIOM Sensis DICOM Application Entity both originates associations for Storage of DICOM Composite Information Objects in Remote Application Entities and receives association requests for Storage from Remote Application Entities.

4.1 Application Data Flow Diagram

The AXIOM Sensis DICOM network implementation is a Windows 2000 application and acts as SCU and SCP for the C-STORE DICOM network service and as SCP for the C-ECHO DICOM network service.

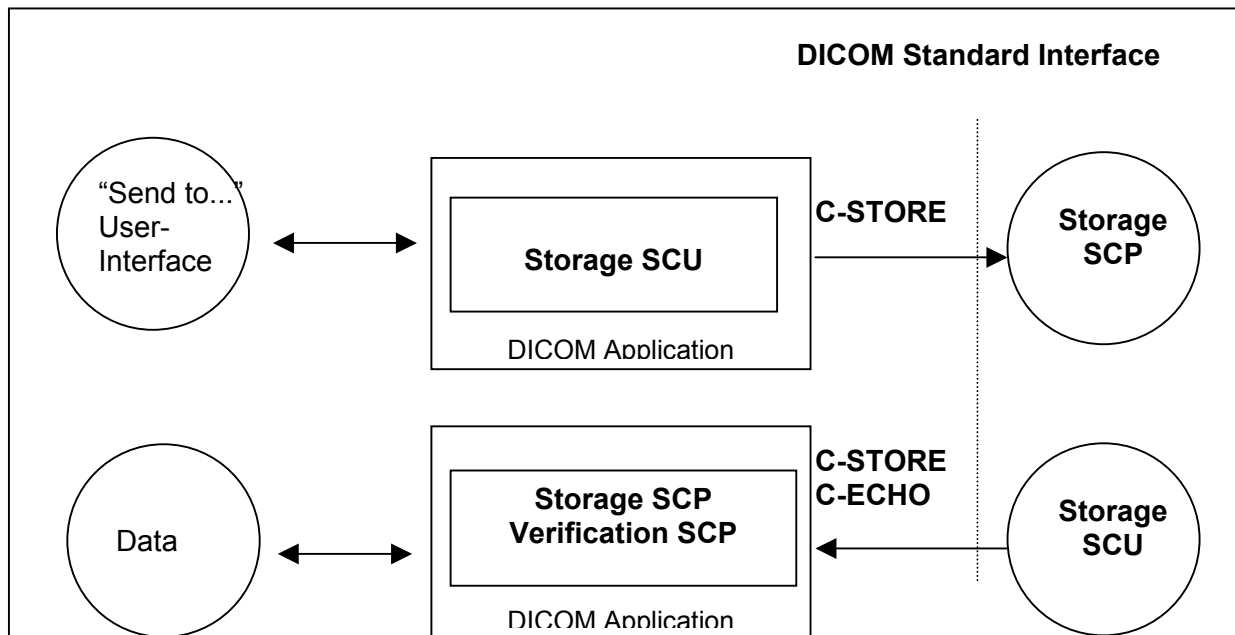

Figure 2: AXIOM Sensis Application Data Flow Diagram – Storage SCU/SCP, Echo SCP

4.2 Functional Definitions of Application Entities

The Storage SCU is invoked by the job control interface that is responsible for processing network archival tasks. The job consists of data describing the composite objects selected for storage and the destination. An association is negotiated with the destination application entity and the data is transferred using the C-STORE DIMSE-Service. Status of the transfer is reported to the job control interface.

The Storage SCP component of the AXIOM Sensis DICOM application is operating as background server process. It is existing when the machine is powered on and waits for Storage association requests. Upon accepting an association with a negotiated Presentation Context it starts to receive the Composite Objects and imports them to local database. Verification requests will be processed and responded by Storage SCP component too.

4.3 Sequencing of Real-World Activities

Not applicable

5 Application Entity Specification Storage

5.1 Storage AEs Specification

The AXIOM Sensis Storage service class user/service class provider applications use one AE when initiating/receiving associations to/from remote DICOM nodes.

SIEMENS AXIOM Sensis DICOM products provide Standard Conformance to the following DICOM V3.0 SOP Classes as an SCU:

SOP Class Name	SOP Class UID
X-Ray Angiographic Image Storage	1.2.840.10008.5.1.4.1.1.12.1
Cardiac Electrophysiology Waveform Storage	1.2.840.10008.5.1.4.1.1.9.3.1

SIEMENS AXIOM Sensis DICOM products provide Private Conformance to the following DICOM V3.0 conform private SOP Classes as an SCU:

SOP Class Name	SOP Class UID
CSA Non-Image Storage	1.3.12.2.1107.5.9.1

SIEMENS AXIOM Sensis DICOM products provide Standard Conformance to the following DICOM V3.0 SOP Classes as an SCP:

SOP Class Name	SOP Class UID
X-Ray Angiographic Image Storage	1.2.840.10008.5.1.4.1.1.12.1
Cardiac Electrophysiology Waveform Storage	1.2.840.10008.5.1.4.1.1.9.3.1
Verification	1.2.840.10008.1.1

SIEMENS AXIOM Sensis DICOM products provide Private Conformance to the following DICOM V3.0 conform private SOP Classes as an SCP:

SOP Class Name	SOP Class UID
CSA Non-Image Storage	1.3.12.2.1107.5.9.1

5.1.1 Association Establishment Policies

5.1.1.1 General

The existence of a job queue entry with network destination will activate the DICOM Storage Application. An association request is sent to the destination AE and upon successful negotiation of a Presentation Context the transfer is started.

The default PDU size used will be 28 KB.

A new Study Instance UID for the study will be generated by the AXIOM Sensis system if the complete study has been stored on an external medium and is later opened for post processing.

5.1.1.2 Number of Associations

The Siemens AXIOM Sensis DICOM application initiates several associations at a time, one for each destination to which a transfer request is being processed in the active job queue list.

5.1.1.3 Asynchronous Nature

The Siemens AXIOM Sensis DICOM software does not support asynchronous communication (multiple outstanding transactions over a single association).

5.1.1.4 Implementation Identifying Information

Implementation Class UID	1.3.12.2.1107.5.9.20000101
Implementation Version Name	"SIEMENS_SWFVC10E"

5.1.2 Association Initiation Policy

If a job with network destination gets active in the job list the Siemens AXIOM Sensis DICOM application attempts to initiate a new association for

- DIMSE C-STORE service operations.

5.1.2.1 Associated Real-World Activity

5.1.2.1.1 Associated Real-World Activity – Send Objects to a Network Destination

The associated Real-World activity is a C-STORE request initiated by an internal daemon process triggered by a job with network destination. If the process successfully establishes an association to a remote Application Entity, it will transfer each object one after another via the open association. If the C-STORE Response from the remote Application contains a status other than "Success" or "Warning", the association is aborted.

5.1.2.1.2 Proposed Presentation Context – Send Objects

The Siemens AXIOM Sensis DICOM application will propose Presentation Contexts as shown in the following table:

Presentation Context Table					
Abstract Syntax		Transfer Syntax		Role	Ext. Neg.
Name	UID	Name List	UID List		
X-Ray Angiographic Image Storage Service Class	1.2.840.10008.5.1.4.1.1.12.1	Implicit VR Little Endian Explicit VR Big Endian Explicit VR Little Endian JPEG Lossless, Process 14 (selection value 1) JPEG Lossy Baseline (Process 1) compression JPEG Lossy Extended (Process 2 & 4)	1.2.840.10008.1.2 1.2.840.10008.1.2.2 1.2.840.10008.1.2.1 1.2.840.10008.1.2.4.70 1.2.840.10008.1.2.4.50 1.2.840.10008.1.2.4.51	SC U	None
Cardiac Electrophysiology Waveform Storage SOP Class	1.2.840.10008.5.1.4.1.1.9.3.1	Implicit VR Little Endian Explicit VR Big Endian Explicit VR Little Endian	1.2.840.10008.1.2 1.2.840.10008.1.2.2 1.2.840.10008.1.2.1	SC U	None
CSA Non-Image Storage	1.3.12.2.1107.5.9.1	Implicit VR Little Endian Explicit VR Big Endian Explicit VR Little Endian	1.2.840.10008.1.2 1.2.840.10008.1.2.2 1.2.840.10008.1.2.1	SC U	None

Note: JPEG compression Transfer Syntaxes are supported only for monochrome images (Photometric Interpretation = "MONOCHROME1" or "MONOCHROME2")

5.1.2.1.3 SOP specific Conformance Statement

The AXIOM Sensis itself will create XA IOD type images from the reporting application. Furthermore a private "Non-Image IOD" will be used to store presentation data and textual report data. The XA IOD will be a "Standard Extended XA Storage" SOP Class.

The AXIOM Sensis (DICOM) application will not change private attributes as long as no modification is done. During a "Save as..." operation all private attributes not defined within the AXIOM Sensis DICOM application will be removed when the new object instance is created.

5.1.2.1.3.1 Optional Attributes

Data Dictionary of DICOM Type 2 and 3 IOD Attributes

Please see "Overview of supplied attributes – X-Ray Angiographic image (ACOM.Report Image)" in the Appendix for a list of all DICOM IOD attributes of type 2 and 3 which are encoded by the AXIOM Sensis applications.

5.1.2.1.3.2 Specialized Information Object Definitions

The DICOM objects created by Siemens AXIOM Sensis DICOM application conform to the DICOM IOD definitions (Standard extended IODs). But they will contain additional private elements, which have to be discarded by a DICOM system when modifying the object.

The DICOM nodes are responsible for data consistency when modifying objects. All unknown private attributes have to be removed upon modification!

Data Dictionary of applied private IOD Attributes

Please see "A.2 Siemens Standard Extended Modules" in the Appendix for definition of the private attributes and the IOD tables in the Appendix for usage in the related IOD encoding.

5.1.2.1.3.3 Image Pixel Attribute Description for Grayscale Images

The Siemens AXIOM Sensis DICOM application supports squared-sized images with the Monochrome2 Photometric Interpretation, the unsigned integer 8 or 16-bit grayscale pixel and graphic overlay format. For 16bit the lower 12 bits are used for pixel and the higher 4 bits are used for the graphic overlay. However no image viewing is possible on AXIOM Sensis.

Pixel plane

- samples per pixel (attribute 0028, 0002) = 1
- photometric interpretation (attribute 0028,0004) = "MONOCHROME2"
- Rows (attribute 0028,0010) <= 1024
- Columns (attribute 0028,0011) <= 1024
- pixel representation (attribute 0028, 0103) = 0
- bits allocated (attribute 0028, 0100) = 8
- bits stored (attribute 0028,0101) = 8
- high bit (attribute 0028,0102) = 7

Overlay plane

- overlay type (attribute 60xx, 0040) = "G"
- bits allocated (attribute 60xx, 0100) = 1
- bit position (attribute 60xx, 0102) = 0
- overlay data (attribute 60xx, 3000) = supported.

5.1.2.1.3.4 Attribute Description for Waveforms

Waveform Sequence

- Sampling Frequency (attribute 003A,001A) = 2000
- Waveform Bits Allocated (attribute 5400,1004) = 16
- Waveform Bits Stored (attribute 003A,021A) = 16
- Modality (attribute 0008,0060) = "EPS". This applies to both the Hemodynamic and Electrophysiology applications in Sensis, because of the same sampling rate of 2000 Hz.

5.1.2.1.3.5 Private Information Object Definitions

To fulfill all application requirements, the AXIOM Sensis DICOM implementation will use private IOD's to store Data currently not defined in the DICOM Standard according the DICOM information model. The privately defined IOD will contain all references to identify the Patient/Study/Series/Instances to which the related information belongs.

Currently this format is used for the “Event Log and Presentation Log objects”.

All IOD used to store this private Information will be based on various Instances of the SIEMENS Non-Image IOD.

Please see “SIEMENS Private Non-Image IOD” and "Private Non-Image IOD" in the Appendix for a detailed overview of the private IOD definition and the IOD tables for value encoding.

Note: The private Non-Image IODs are necessary for opening and viewing a Sensis study. So it is mandatory that any DICOM node handling the Sensis study also supports these IODs.

5.1.3 Association Acceptance Policy

The Siemens AXIOM Sensis DICOM application attempts to accept a new association for

- DIMSE C-ECHO
- DIMSE C-STORE

service operations. Any Information Objects transmitted on that association will be checked on conformance and stored in database if check was successful.

5.1.3.1 Associated Real-World Activity

5.1.3.1.1 Associated Real-World Activity – Receiving Objects from a Remote Node

The daemon receiving process will accept an association and will receive any objects transmitted on that association and will store the objects on disk in the own database if the conformance check is performed successfully.

5.1.3.1.2 Presentation Context Table

The Siemens AXIOM Sensis DICOM application will accept Presentation Contexts as shown in the following table:

Presentation Context Table					
Abstract Syntax		Transfer Syntax		Role	Ext. Neg.
Name	UID	Name List	UID List		
X-Ray Angiographic Image Storage Service Class	1.2.840.10008.5.1.4.1.1.12.1	Implicit VR Little Endian Explicit VR Big Endian Explicit VR Little Endian JPEG Lossless, Process 14 (selection value 1) JPEG Lossy Baseline (Process 1) compression JPEG Lossy Extended (Process 2 & 4)	1.2.840.10008.1.2 1.2.840.10008.1.2.2 1.2.840.10008.1.2.1 1.2.840.10008.1.2.4.70 1.2.840.10008.1.2.4.50 1.2.840.10008.1.2.4.51	SCP	None
Cardiac Electrophysiology Waveform Storage SOP Class	1.2.840.10008.5.1.4.1.1.9.3.1	Implicit VR Little Endian Explicit VR Big Endian Explicit VR Little Endian	1.2.840.10008.1.2 1.2.840.10008.1.2.2 1.2.840.10008.1.2.1	SCP	None
CSA Non-Image Storage	1.3.12.2.1107.5.9.1	Implicit VR Little Endian Explicit VR Big Endian Explicit VR Little Endian	1.2.840.10008.1.2 1.2.840.10008.1.2.2 1.2.840.10008.1.2.1	SCP	None

Presentation Context Table					
Abstract Syntax		Transfer Syntax		Role	Ext. Neg.
Name	UID	Name List	UID List		
Verification	1.2.840.10008.1.1	Implicit VR Little Endian Explicit VR Big Endian Explicit VR Little Endian	1.2.840.10008.1.2 1.2.840.10008.1.2.2 1.2.840.10008.1.2.1	SCP	None

Note: JPEG compression Transfer Syntaxes are supported only for monochrome images (Photometric Interpretation = "MONOCHROME1" or "MONOCHROME2")

The AXIOM Sensis DICOM storage provider will only accept MONOCHROME_{EX} encoded images. Color encoded images (RGB or Palette Color) are not supported.

5.1.3.1.3 SOP-specific Conformance Statement

The Siemens AXIOM Sensis DICOM application conforms to the Full Storage Class at Level 2. In the event of a successful C-STORE operation, the object has successfully been written on disk in the Siemens AXIOM Sensis image/waveform format. For Private Attributes of VR=SQ, only a nesting level of one is supported. This means that Private Sequences containing another Sequence will be removed from the image header during Storage.

The AXIOM Sensis DICOM receiver returns the status Success upon successful operation otherwise one of the following status codes is returned and the association is aborted:

- Refused (A700):
This error status indicates a lack of Resources (e.g. not enough disk space) on the AXIOM Sensis modality.
- Error (A900 or C000):
An error occurred while processing the object, which makes it impossible to proceed. The object will not be stored and the association aborted.

If an object instance is received that is identified by a SOP Instance UID that is already used by an Instance stored in database, then the actual received object will be discarded. The existing Instance is not superseded.

The following sections will differentiate the attribute contents required for Image Viewing. The Siemens AXIOM Sensis DICOM application supports more formats for Storage of Images. However in this release image viewing will not be supported on AXIOM Sensis.

5.1.3.1.3.1 Image Pixel Attribute Acceptance Criterion for Grayscale Images

The AXIOM Sensis application accepts the MONOCHROME1 and MONOCHROME2 photometric interpretation pixel format and graphic overlay with unsigned integer and 8 or 16 bits allocated. The Pixel Matrix has to be in square format. Accepted values:

Pixel plane

- samples per pixel (attribute 0028, 0002) = 1
- photometric interpretation (attribute 0028,0004) = "MONOCHROME1", "MONOCHROME2"
- Rows (attribute 0028,0010) = 512, 1024
- Columns (attribute 0028,0011) = 512, 1024
- pixel representation (attribute 0028, 0103) = 0
- bits allocated (attribute 0028, 0100) = 8, 16
- bits stored (attribute 0028,0101) = 8, 10, 12
- high bit (attribute 0028,0102) = 7, 9, 11

Overlay plane

- overlay type (attribute 60xx, 0040) = "G"
- bits allocated (attribute 60xx, 0100) = 16
- bit position (attribute 60xx, 0102) = 12, 13, 14, 15

Graphic Overlay will be shifted to fill Overlay Planes from Bit 12 and consecutive.

Overlay plane

- overlay type (attribute 60xx, 0040) = "G"
- bits allocated (attribute 60xx, 0100) = 1
- bit position (attribute 60xx, 0102) = 0
- overlay data (attribute 60xx, 3000) = supported

5.1.3.1.3.2 Restrictions for Waveforms

In Sensis VC01A only Waveforms generated by Sensis can be displayed and only if the corresponding NonImage objects are present in the same study.

The maximum size for Waveform objects is 600 MB in order to make them fit one CD for export and long term storage.

5.1.3.1.4 Presentation Context Acceptance Criterion

The AXIOM Sensis DICOM application will accept any number of verification or storage SOP classes that are listed above. The number of presentation contexts accepted is limited to the maximum of 127 (DICOM limit). In the event that the Siemens AXIOM Sensis DICOM application runs out of resources, it will reject the association request.

5.1.3.1.5 Transfer Syntax Selection Policies

The AXIOM Sensis DICOM application currently supports

- the Implicit VR Little Endian, the Explicit VR Little Endian and Explicit VR Big Endian Transfer Syntaxes
- the JPEG Lossless Non-hierarchical Transfer Syntax
- the JPEG Baseline and JPEG Extended Transfer Syntaxes (JPEG Lossy).

Any proposed presentation context including one of these Transfer Syntaxes will be accepted. Any proposed presentation context that does not include one of these Transfer Syntaxes will be rejected.

With Implicit VR Little Endian Transfer Syntax the AXIOM Sensis DICOM application will remove any Private Attributes not known to the application. Decision on removal of a Private Element is done if there is NO entry in the attribute-dictionary of the AXIOM Sensis DICOM application.

Therefore any Explicit VR Transfer Syntax shall preferably be used by the Storage SCU's when sending Composite Image Instances to the AXIOM Sensis DICOM application.

6 Implementation Model Storage Commitment

The Storage Commitment service class defines an application-level class of service which facilitates the commitment to storage. It performs an additional task of commitment of composite objects apart from the network based storage of objects as defined by the Storage Service class. The AXIOM Sensis DICOM implementation supports the Storage Commitment Push Model as SCU and SCP.

6.1 Application Data Flow Diagram

The AXIOM Sensis DICOM network implementation is a Windows XP application and acts as SCU/SCP for the Storage Commitment Push Model Service using the Storage Commitment Service Class.

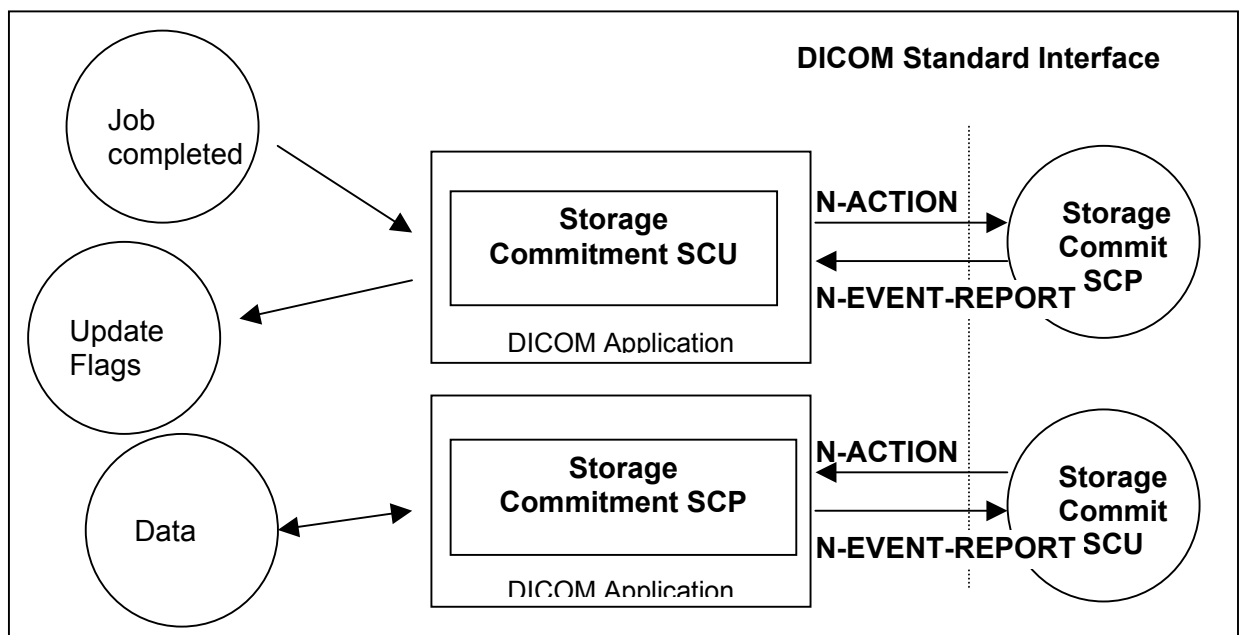

Figure 3: Application Data Flow Diagram – Storage Commitment SCU/SCP

6.2 Functional Definitions of Application Entities

With each successfully completed send job, the AXIOM Sensis DICOM Application will populate the Storage Commitment Push Model Action Information from the SOP Instances sent. Then an a Storage Commit Request is triggered. Depending on configuration, the AXIOM Sensis DICOM application will keep the association open for responses with a configurable time-out, or closes the association and expects responses on a different association that has to be establishes by the remote Storage Commitment SCP.

The commitment status derived from the related trigger response will be indicated in the related Status Flags of the related entity. It is possible to create triggers ("auto rules") from this event.

Note: Only instances saved in database can be tagged with Status Flags. Therefore any temporary objects sent, will not have any indication about successful commitment.

The Transaction UIDs of the pending commitment request are kept "open" (Job-status is "waiting") for a configurable amount in time (default: 1h). If the "open time" for a pending commitment request has elapsed w/o a related response from the provider, the Transaction UID is removed and the related entities are indicated as "commit failed".

In any case, commitment will only be requested for previously and successfully sent instances.

The Storage Commitment SCP is running in background and is ready to receive request when the system is started.

6.3 Sequencing of real World Activities

The Storage Commitment trigger is automatically derived from the successful completion of a Send Job.

7 AE Specification Storage Commitment

7.1 Storage Commitment AE Specification

The Siemens AXIOM Sensis DICOM Application Entity provides Standard Conformance to the following DICOM SOP Class as an SCU and SCP:

SOP Class Name	SOP Class UID
Storage Commitment Push Model	1.2.840.10008.1.20.1

7.1.1 Association Establishment Policies

7.1.1.1 General

With a Send Job successfully completed, the DICOM application will generate the Storage Commitment Action Information which references to all Instances of the processed job. The Commit Request is then sent over a single opened association. AXIOM Sensis will wait for Status responses of the Storage Commitment Request. If the Provider accepts the Storage Commitment with Success Status, the generated Transaction UID, together with study identification data and a time-stamp, is kept. Depending on configuration, the association is closed when the configured time-out has elapsed or a response was received before. If the association is closed before a response was received, the response is then expected on a different association. Multiple Storage Commitment Requests can be pending.

The default PDU size used will be 256 KB.

7.1.1.2 Number of Associations

The AXIOM Sensis DICOM application initiates several associations at a time, one for each destination to which a transfer request is being processed in the active job queue list.

The AXIOM Sensis DICOM application is able to accept multiple associations at a time. It can handle up to 10 associations in parallel.

7.1.1.3 Asynchronous Nature

The AXIOM Sensis DICOM software does not support asynchronous communication (multiple outstanding transactions over a single association).

7.1.1.4 Implementation Identifying Information

Implementation Class UID	1.3.12.2.1107.5.4.7
Implementation Version Name	"SIEMENS_SWFVC10E"

7.1.2 Association Initiation Policy

The AXIOM Sensis DICOM Application Entity acts as a Service Class User (SCU) for the

- Storage Commitment Push Model Service Class (to request commitment for storage of instances previously sent).

To do so, AXIOM Sensis will issue a

- N-ACTION DIMSE to request commitment or a
- N-EVENT-REPORT DIMSE to respond to a received storage commitment request and the association was closed by the remote system prior to response.

7.1.2.1 Real World Activity – Storage Commitment

7.1.2.1.1 Associated Real-World Activity - Job Completed

The AXIOM Sensis Storage Commitment application sends the commit request (N-ACTION-RQ) message and waits for acceptance of this request (N-ACTION-RSP). After receiving this, the transaction is marked as “waiting”.

Depending on a configuration value, the association will then be closed or kept open. In the first case, there is another configurable timeout giving the number of hours (h) and minutes (m) (by default 1h:0m) to wait for the corresponding commit response (N-EVENT-REPORT). In the second case, this time is the (also configurable) time-out for the association. For both cases, if the commit response (N-EVENT-REPORT) does not arrive during the configured time, the transaction will be marked as failed. AXIOM Sensis does not re-send instances from a failed Storage Commitment result in any case.

If the commit response (N-EVENT-REPORT) received has the status of “complete - failure exists”, the transaction is marked as failed, else the transaction is marked as “completed”; In both cases, a message is shown to the user.

7.1.2.1.2 Proposed Presentation Contexts - Job Completed

The AXIOM Sensis DICOM application will propose Presentation Contexts as shown in the following table:

Presentation Context Table					
Abstract Syntax		Transfer Syntax		Role	Ext. Neg.
Name	UID	Name List	UID List		
Storage Commitment Push Model	1.2.840.10008.1.20.1	Implicit VR Little Endian Explicit VR Little Endian Explicit VR Big Endian	1.2.840.10008.1.2 1.2.840.10008.1.2.1 1.2.840.10008.1.2.2	SC U	None

7.1.2.1.3 SOP Specific Conformance Statement- Job Completed

Storage Commitment is supported for all the SOP class UIDs as mentioned in 'Acceptable presentation contexts - Storage' in the Storage SCP section of this document.

The Referenced Study Component Sequence is not supported.

Storage Media File-Set ID and UID Attributes will not be supported in the commitment request (N-ACTION primitive) invoked by the Storage Commitment SCU.

7.1.2.1.4 Associated Real-World Activity - Send Commit Response

Acting as an Storage Commitment Provider, the AXIOM Sensis Storage Commitment AE received a Storage Commitment request, carried out the request, and is ready to send back the response, but the association is not open anymore. In this case it will by itself initiate an association to send the storage commitment response (N-EVENT-REPORT) to the SCU.

7.1.2.1.5 Proposed Presentation Contexts - Send Commitment Response

The Siemens AXIOM Sensis DICOM application will propose Presentation Contexts as shown in the following table:

Presentation Context Table					
Abstract Syntax		Transfer Syntax		Role	Ext. Neg.
Name	UID	Name List	UID List		
Storage Commitment Push Model	1.2.840.10008.1.20.1	Implicit VR Little Endian Explicit VR Little Endian Explicit VR Big Endian	1.2.840.10008.1.2 1.2.840.10008.1.2.1 1.2.840.10008.1.2.2	SCP	None

7.1.2.1.6 SOP Specific Conformance Statement - Send Commitment Response

Storage Media File-Set ID and UID Attributes will not be supported in the N-EVENT-REPORT primitive invoked by the Storage Commitment SCP.

7.1.3 Association Acceptance Policy

The AXIOM Sensis DICOM Application Entity acts as a Service Class Provider (SCP) for the

- Storage Commitment Push Model Service Class (Give a commitment to store previously received instances).

To do so, the AXIOM Sensis attempts to accept a

- N-ACTION DIMSE to receive a commitment request for the instance included or a
- N-EVENT-REPORT DIMSE to receive a storage commitment response from a previous request and the SCP behavior requires a different association than the commit request.

7.1.3.1 Associated Real-World Activity - Commit SCP

7.1.3.1.1 Associated Real-World Activity - Receive Commit Request

When receiving an Storage Commitment request the AXIOM Sensis DICOM application will perform the necessary steps to check the received list Instances against the local database.

7.1.3.1.2 Accepted Presentation Contexts - Receive Commit Request

The Siemens AXIOM Sensis DICOM application will accept Presentation Contexts as shown in the following table:

Presentation Context Table					
Abstract Syntax		Transfer Syntax		Role	Ext. Neg.
Name	UID	Name List	UID List		
Storage Commitment Push Model	1.2.840.10008.1.20.1	Implicit VR Little Endian Explicit VR Little Endian Explicit VR Big Endian	1.2.840.10008.1.2 1.2.840.10008.1.2.1 1.2.840.10008.1.2.2	SC P	None

7.1.3.1.3 SOP-specific Conformance Statement - Receive Commit Request

The AXIOM Sensis Storage Commitment AE will return success for instances that are stored in the local database and failure for instances that are not. However, the committed instances can later be deleted by the user on the SCP side!

Note: Storage Media File-Set ID and UID Attributes will not be supported in the N-EVENT-REPORT primitive invoked by the Storage Commitment SCP.

7.1.3.2 Associated Real-World Activity - Commit SCU

7.1.3.2.1 Associated Real-World Activity - Update Flags

The AXIOM Sensis Storage Commitment DICOM Application has sent a Storage Commitment Request and, being configured to receive response on a separate association, has closed the association, and now it gets an association request from the Storage Commitment SCP that want to send the results. The AXIOM Sensis DICOM application will await Storage commitment Notification triggers. Any incoming Notification will be checked for validity, that is, if the related Transaction UID is still part of the Pending Request Queue.

If the Notification is valid, the Notification Event Information is evaluated and the related Instances are marked with the related status. The over-all Commit Status of the higher Information Entities is derived from propagation of the States of all instance entities included in a study.

The Status Flags directly affected by Storage Commitment results and indicated in the different entities of the Patient Browser list can be one of

- “AC” or “SC” - Successful Commitment, A means archived to configured Archive destination, whereas S means sent to any other destination.
- “Af” or “Sf” - Commitment failed.
- “A?” or “S?” - Commitment request is sent, response is pending.

In case of failure the user has to repeat the transfer of instances to the Archive destination. Another Storage Commitment will be performed after sending is completed successfully.

Note: Setting of Status Flags is only possible for previously stored instances. Any temporary instance sent, will not be affected by a Commit Response, due to the fact that there is no permanent data-set to be updated.

7.1.3.2.2 Accepted Presentation Contexts - Update Flags

The Siemens AXIOM Sensis DICOM application will accept Presentation Contexts as shown in the following table:

Presentation Context Table					
Abstract Syntax		Transfer Syntax		Role	Ext. Neg.
Name	UID	Name List	UID List		
Storage Commitment Push Model	1.2.840.10008.1.20.1	Implicit VR Little Endian Explicit VR Little Endian Explicit VR Big Endian	1.2.840.10008.1.2 1.2.840.10008.1.2.1 1.2.840.10008.1.2.2	SC U	None

7.1.3.2.3 SOP-specific Conformance Statement - Update Flags

If the Commitment response (N-EVENT-REPORT) received has the status of “complete - failure exists”, the transaction is marked as failed, else the transaction is marked as “completed”; In both cases, a message is shown to the user.

The related status flags are set for the committed instances in the local database.

The AXIOM Sensis DICOM application will NOT support the Storage Media File Set ID attributes.

8 Implementation Model Query / Retrieve

The query/retrieve service class defines an application-level class of services which facilitates the management of images, waveforms, non-image and patient data against the well-defined information model of DICOM and allows a DICOM AE to retrieve objects from a remote DICOM node. The AXIOM Sensis DICOM query/retrieve application supports the query/retrieve services to act as SCU and SCP.

8.1 Application Data Flow Diagram

The AXIOM Sensis DICOM network implementation is a Windows 2000 application and acts as SCU and SCP for the query/retrieve network service.

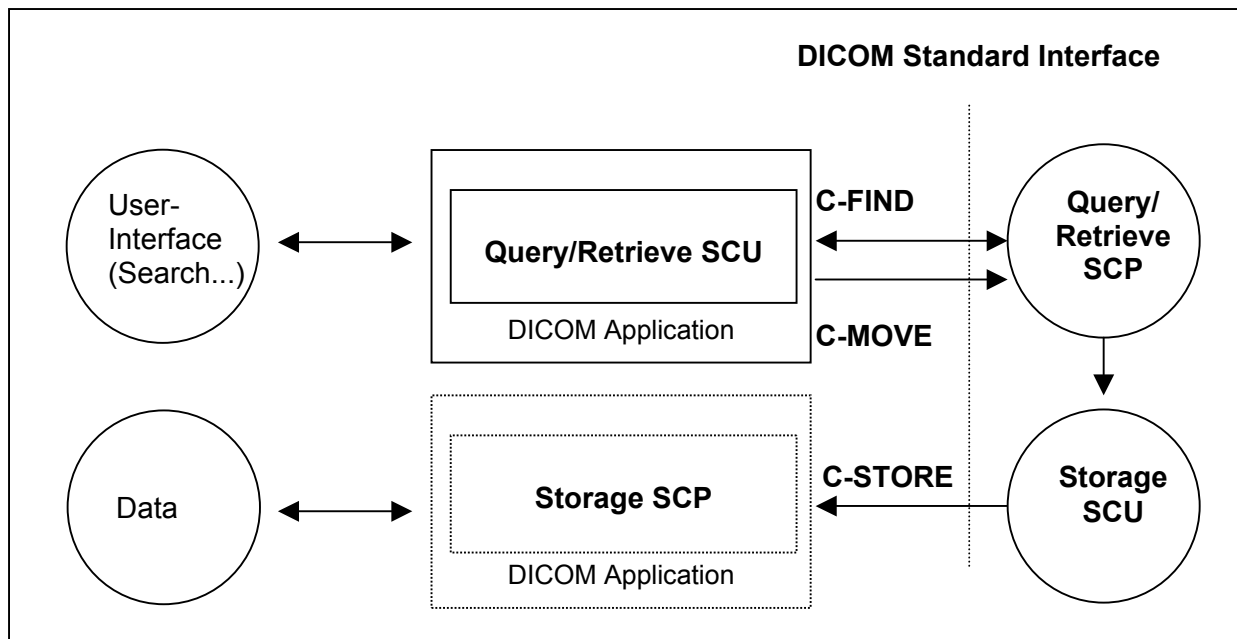

Figure 3: AXIOM Sensis Application Data Flow Diagram – Query/Retrieve SCU

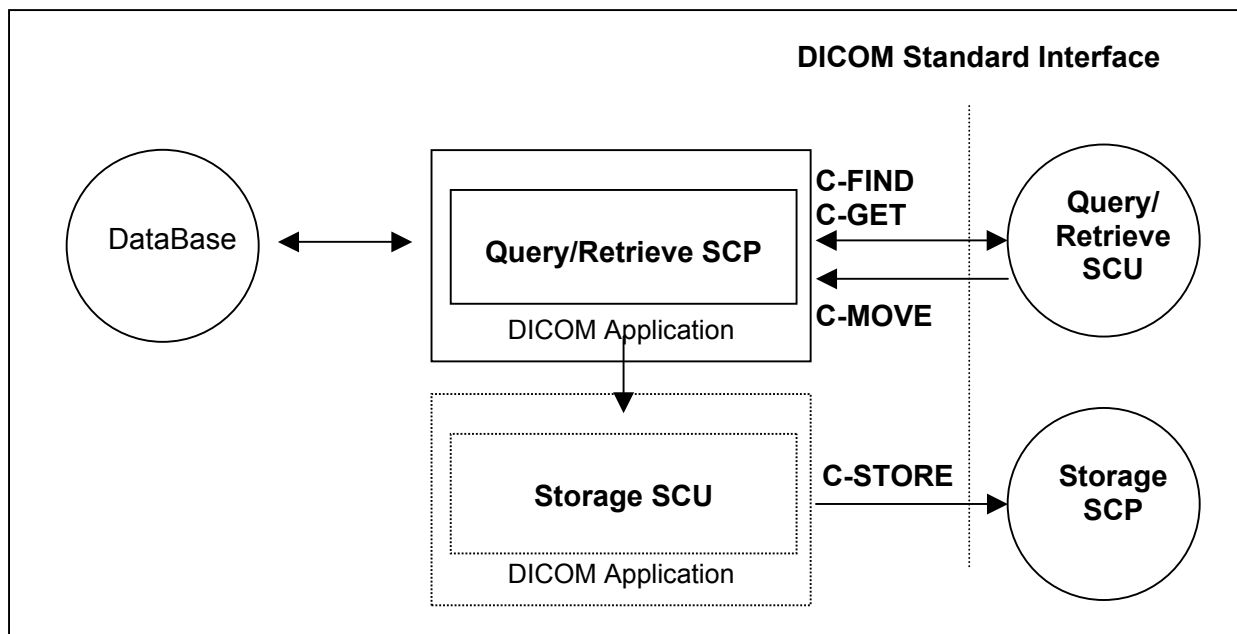

Figure 4: AXIOM Sensis Application Data Flow Diagram – Query/Retrieve SCP

8.2 Functional Definitions of Application Entities

The AXIOM Sensis DICOM query/retrieve SCU requests the remote query/retrieve SCP to perform a search and match to the keys specified in the request in order to display the results in the AXIOM Sensis user interface. Depending on user action (Import) the AXIOM Sensis DICOM SCU sends a C-MOVE DIMSE service to initiate a C-STORE sub-operation on the SCP to start an instance transfer from remote Storage SCU (running on Query/Retrieve SCP) to the AXIOM Sensis Storage SCP.

The AXIOM Sensis DICOM query/retrieve SCP responds to C-FIND DIMSE services from remote SCU. Depending on further remote requests, a C-GET or a C-MOVE involves the Siemens AXIOM Sensis DICOM query/retrieve SCP application to initiate a C-STORE association (by triggering and parametrizing the own Storage SCU) to send objects to a remote Storage SCP.

All components of the Siemens DICOM query/retrieve SCP application are operating as background server processes. They are existing when the machine is powered on and then respond to queries based on the records stored in its database.

8.3 Sequencing of Real-World Activities

Retrieve of objects is only possible if results from a previous "Search..." operation exist and those entities can be selected for "Import".

9 Application Entity Specification Query/Retrieve

9.1 Query/Retrieve Service AEs Specification

The Query/Retrieve SCU requests that the remote SCP performs a match of all keys specified in the request, against the information in its database and the identified instances will be moved over a different (C-MOVE) storage association.

The Query/Retrieve SCP responds to queries based on the records based on its database and instances will be sent to the requesting SCU or to a different storage destination.

SIEMENS AXIOM Sensis DICOM products provide Standard Conformance to the following DICOM V3.0 SOP Classes as SCU:

SOP Class Name	SOP Class UID
Patient Root Query/Retrieve Information Model - FIND	1.2.840.10008.5.1.4.1.2.1.1
Patient Root Query/Retrieve Information Model - MOVE	1.2.840.10008.5.1.4.1.2.1.2
Study Root Query/Retrieve Information Model - FIND	1.2.840.10008.5.1.4.1.2.2.1
Study Root Query/Retrieve Information Model - MOVE	1.2.840.10008.5.1.4.1.2.2.2

SIEMENS AXIOM Sensis DICOM products provide Standard Conformance to the following DICOM V3.0 SOP Classes as an SCP:

SOP Class Name	SOP Class UID
Patient Root Query/Retrieve Information Model - FIND	1.2.840.10008.5.1.4.1.2.1.1
Patient Root Query/Retrieve Information Model - MOVE	1.2.840.10008.5.1.4.1.2.1.2
Patient Root Query/Retrieve Information Model - GET	1.2.840.10008.5.1.4.1.2.1.3
Study Root Query/Retrieve Information Model - FIND	1.2.840.10008.5.1.4.1.2.2.1
Study Root Query/Retrieve Information Model - MOVE	1.2.840.10008.5.1.4.1.2.2.2
Study Root Query/Retrieve Information Model - GET	1.2.840.10008.5.1.4.1.2.2.3
Patient/Study Only Query/Retrieve Information Model - FIND	1.2.840.10008.5.1.4.1.2.3.1
Patient/Study Only Query/Retrieve Information Model - MOVE	1.2.840.10008.5.1.4.1.2.3.2
Patient/Study Only Query/Retrieve Information Model - GET	1.2.840.10008.5.1.4.1.2.3.3

Note: See also the Storage DICOM Conformance Statement of the Siemens AXIOM Sensis DICOM application to compare for conformance of the C-STORE sub-operation generated by the C-GET or C-MOVE DIMSE services. Furthermore compare the supported Storage Service SOP classes described in the Storage DICOM Conformance Statement of the Modality to which the instances shall be transferred to.

9.1.1 Association Establishment Policies

9.1.1.1 General

With the "Search..." function the query data are input and the DICOM query/retrieve application is started. A query request will be sent out to one or more remote nodes and the response data will be displayed for the user. Upon request (Import), the retrieval of selected items is initiated.

The default PDU size used will be 28 KB.

A new Study Instance UID for the study will be generated by the AXIOM Sensis system if the complete study has been received and is opened for post processing.

9.1.1.2 Number of Associations

The Siemens AXIOM Sensis DICOM application initiates one association for each query request being processed to a remote node. The maximum number of active associations is configurable.

9.1.1.3 Asynchronous Nature

The Siemens AXIOM Sensis DICOM software does not support asynchronous communication (multiple outstanding transactions over a single association).

9.1.1.4 Implementation Identifying Information

Implementation Class UID	1.3.12.2.1107.5.9.20000101
Implementation Version Name	"SIEMENS_SWFVC10E"

9.1.2 Association Initiation Policy

The query user interface will request the query-data from user and triggers one C-FIND request to the selected remote node. The response data will be displayed in the query UI for further data navigation.

When requesting Import of related items the browser requests the retrieve application to send a C-MOVE request to the related remote node. Objects will then be received by the Storage SCP as described in the related section.

9.1.2.1 Real World Activity - Find SCU

9.1.2.1.1 Associated Real-World Activity - Find SCU (Search...)

The associated Real-World activity is to fill out a query form with search data and pass it as query to the network application which issues a C-FIND over a previously built association. The remote SCP will respond with related data-entries that will be passed to a browser application. When data transfer is finished the association is closed.

9.1.2.1.2 Proposed Presentation Contexts - Find SCU

The Siemens AXIOM Sensis DICOM application will propose Presentation Contexts as shown in the following table:

Presentation Context Table					
Abstract Syntax		Transfer Syntax		Role	Ext. Neg.
Name	UID	Name List	UID List		
Patient Root Query/Retrieve Model - FIND	1.2.840.10008.5.1.4.1.2.1.1	Implicit VR Little Endian Explicit VR Big Endian Explicit VR Little Endian	1.2.840.10008.1.2 1.2.840.10008.1.2.2 1.2.840.10008.1.2.1	SCU	None
Study Root Query/Retrieve Model - FIND	1.2.840.10008.5.1.4.1.2.2.1	Implicit VR Little Endian Explicit VR Big Endian Explicit VR Little Endian	1.2.840.10008.1.2 1.2.840.10008.1.2.2 1.2.840.10008.1.2.1	SCU	None

It is configurable which of the two query models (or both) are to be used by the AXIOM Sensis DICOM Query SCU application.

9.1.2.1.3 SOP Specific Conformance Statement - Find SCU

The Siemens AXIOM Sensis DICOM Query/Retrieve SCU supports hierarchical queries with all mandatory search keys. The interactive querying of attributes on INSTANCE level is not supported by the Query SCU, hence retrieval of individual Objects is possible. The following table describes the search keys for the different query models that the SCU supports. Matching is either wildcard, which means that the user can supply a string containing wildcards, or universal, which means that the attribute is requested as return value.

Attribute Name	Tag	Type	Matching	User Input	Return Value Display
Patient Level¹					
Patient Name	(0010,0010)	R	Wildcard ²	Enter value	yes
Patient ID	(0010,0020)	U / R	Wildcard ^b	Enter value	yes
Patient's Birthdate	(0010,0030)	O	Universal(Null)	--	yes
Patient's Sex	(0010,0040)	O	Universal(Null)	--	yes
Number of Patient related Studies	(0020,1200)	O	Universal(Null)	--	yes
Number of Patient related Series	(0020,1202)	O	Universal(Null)	--	yes
Number of Patient related Instances	(0020,1204)	O	Universal(Null)	--	yes
Study Level					
Patient Name ³	(0010,0010)	R	Wildcard	Enter value	yes
Patient ID ^c	(0010,0020)	U / R	Wildcard	Enter value	yes
Study Instance UID	(0020,000D)	U	Single value	Select from List	yes
Study ID	(0020,0010)	R	Universal(Null)	--	yes
Study Date	(0008,0020)	R	Universal(Null)	--	yes
Study Time	(0008,0030)	R	Universal(Null)	--	yes
Accession Number	(0008,0050)	R	Universal(Null)	--	yes
Study Description	(0008,1030)	O	Universal(Null)	--	yes
Referring Physician's name	(0008,0090)	O	Universal(Null)	--	yes
Name of Physician Reading Study	(0008,1060)	O	Universal(Null)	--	yes
Modalities in Study	(0008,0061)	O	Universal(Null)	--	yes
Storage Media File-Set ID	(0008,0130)	O	Universal(Null)	--	yes
Retrieve AE Title	(0008,0054)	O	Universal(Null)	--	yes
Number of Study related Series	(0020,1206)	O	Universal(Null)	--	yes
Number of Study related Instances	(0020,1208)	O	Universal(Null)	--	yes

¹ Patient Root Information Model only

² Always a "*" is appended to the user-supplied string

³ Study Root Information Model only

Series Level					
Series Instance UID	(0020,000E)	U	Single Value	Select from List	yes
Series Number	(0020,0011)	R	Universal(Null)	--	yes
Modality	(0008,0060)	R	Universal(Null)	--	yes
Series Date	(0008,0021)	O	Universal(Null)	--	yes
Series Time	(0008,0031)	O	Universal(Null)	--	yes
Series Description	(0008,103E)	O	Universal(Null)	--	yes
Storage Media File-Set ID	(0008,0130)	O	Universal(Null)	--	yes
Retrieve AE Title	(0008,0054)	O	Universal(Null)	--	yes
Protocol Name	(0018,1030)	O	Universal(Null)	--	yes
Performed Procedure Step Start Date	(0040,0244)	O	Universal(Null)	--	yes
Performed Procedure Step Start Time	(0040,0245)	O	Universal(Null)	--	yes
Number of Series related Instances	(0020,1209)	O	Universal(Null)	--	yes
Instance Level					
SOP Instance UID	(0008,0018)	U	Single Value	--	yes
Instance Number	(0020,0013)	R	Universal(Null)	--	yes
Storage Media File-Set ID	(0008,0130)	O	Universal(Null)	--	yes
Retrieve AE Title	(0008,0054)	O	Universal(Null)	--	yes
Instance Date	(0008,0023)	O	Universal(Null)	--	yes
Instance Time	(0008,0033)	O	Universal(Null)	--	yes
Number of Frames	(0028,0008)	O	Universal(Null)	--	yes
Image Comments	(0020,4000)	O	Universal(Null)	--	yes

The Find SCU interprets following status codes:

Service Status	Meaning	Error Codes	Related Fields
Refused	Out of Resources	A700	(0000,0902)
Failed	Identifier does not match SOP Class	A900	(0000,0901) (0000,0902)
	Unable to process	Cxxx	(0000,0901) (0000,0902)
Cancel	Matching terminated due to Cancel request	FE00	None
Success	Matching is complete - No final Identifier is supplied	0000	None
Pending	Matches are continuing - Current Match is supplied and any Optional Keys were supported in the same manner as Required Keys	FF00	Identifier
	Matches are continuing - Warning that one or more Optional Keys were not supported for existence and/or matching for this identifier	FF01	Identifier

9.1.2.2 Real-World Activity – Move SCU

9.1.2.2.1 Associated Real-World Activity – Move SCU (Import)

When selecting a data entry in the Query UI and activate the "Import" function, a retrieval request is passed to the archival application which issues a C-MOVE service according to the Patient Root or Study Root query model. (The Storage Service Class Conformance Statement describes the C-STORE service, which is generated by processing the C-MOVE service.)

The transferred object data are processed as described in the storage class SCP descriptions.

The possibility to request the remote C-MOVE provider (remote application that responded to the C-FIND) to move data to an application entity other than the C-MOVE SCU (the AXIOM Sensis DICOM application) is NOT USED.

9.1.2.2.2 Proposed Presentation Contexts - Move SCU

The Siemens AXIOM Sensis DICOM application will propose Presentation Contexts as shown in the following table:

Presentation Context Table					
Abstract Syntax		Transfer Syntax		Role	Ext. Neg.
Name	UID	Name List	UID List		
Patient Root Query/Retrieve Model – MOVE	1.2.840.10008.5.1.4.1.2.1.2	Implicit VR Little Endian Explicit VR Big Endian Explicit VR Little Endian	1.2.840.10008.1.2 1.2.840.10008.1.2.2 1.2.840.10008.1.2.1	SCU	None
Study Root Query/Retrieve Model – MOVE	1.2.840.10008.5.1.4.1.2.2.2	Implicit VR Little Endian Explicit VR Big Endian Explicit VR Little Endian	1.2.840.10008.1.2 1.2.840.10008.1.2.2 1.2.840.10008.1.2.1	SCU	None

Note: C-MOVE extended negotiation will not be supported by the SCU

C-MOVE operation on PATIENT level is not supported by AXIOM Sensis application.

9.1.2.2.3 SOP Specific Conformance Statement - Move SCU

At association establishment time the C-MOVE presentation context shall be negotiated. The C-STORE sub-operations must be done on a different association to transfer objects to the own Storage Service Class SCP.

The Move SCU interprets following status codes:

Service Status	Meaning	Error Codes	Related Fields
Refused	Out of Resources - Unable to calculate number of matches	A701	(0000,0902)
	Out of Resources - Unable to perform sub operations	A702	(0000,1020) (0000,1021) (0000,1022) (0000,1023)
Failed	Identifier does not match SOP Class	A900	(0000,0901) (0000,0902)
	Unable to process	Cxxx	(0000,0901) (0000,0902)
Cancel	Sub-operations terminated due to Cancel Indication	FE00	(0000,1020) (0000,1021) (0000,1022) (0000,1023)
Warning	Sub-operations Complete - One or more Failures of Warnings	B000	(0000,1020) (0000,1021) (0000,1022) (0000,1023)
Success	Sub-operations Complete - No Failures or Warning	0000	(0000,1020) (0000,1021) (0000,1022) (0000,1023)
Pending	Sub-operations are continuing	FF00	(0000,1020) (0000,1021) (0000,1022) (0000,1023)

9.1.3 Association Acceptance Policy

The Siemens AXIOM Sensis DICOM application will accept associations for the following DIMSE-C operations as SCP:

- C-FIND
- C-GET
- C-MOVE
- C-FIND-CANCEL
- C-GET-CANCEL
- C-MOVE-CANCEL

Extended negotiation - which is relational retrieve - is NOT supported for the above listed services. The AXIOM Sensis DICOM application does support multiple C-FIND requests over the same association, while multiple C-MOVE or C-GET operations are NOT supported over the same association.

9.1.3.1 Real-World Activity - Find SCP

9.1.3.1.1 Associated Real-World Activity – Accept Find request to SCP

The associated Real-World activity is to respond query requests to an SCU with the query model Patient Root, Study Root and Patient/Study Only. Relational retrieve operation is NOT supported. With a C-FIND-CANCEL request the running query can be canceled at any time.

Multiple C-FIND requests over the same association are supported.

9.1.3.1.2 Accepted Presentation Contexts - Find SCP

The Siemens AXIOM Sensis DICOM application will accept Presentation Contexts as shown in the following table

Presentation Context Table					
Abstract Syntax		Transfer Syntax		Role	Ext. Neg.
Name	UID	Name List	UID List		
Patient Root Query/Retrieve Model – FIND	1.2.840.10008.5.1.4.1.2.1.1	Implicit VR Little Endian Explicit VR Little Endian Explicit VR Big Endian	1.2.840.10008.1.2 1.2.840.10008.1.2.1 1.2.840.10008.1.2.2	SCP	None
Study Root Query/Retrieve Model – FIND	1.2.840.10008.5.1.4.1.2.2.1	Implicit VR Little Endian Explicit VR Little Endian Explicit VR Big Endian	1.2.840.10008.1.2 1.2.840.10008.1.2.1 1.2.840.10008.1.2.2	SCP	None
Patient/Study Only Query/Retrieve Model – FIND	1.2.840.10008.5.1.4.1.2.3.1	Implicit VR Little Endian Explicit VR Little Endian Explicit VR Big Endian	1.2.840.10008.1.2 1.2.840.10008.1.2.1 1.2.840.10008.1.2.2	SCP	None

Note: C-FIND Extended Negotiation will NOT be supported.
The order of preference for accepting Transfer Syntaxes is: 1. Explicit VR Little Endian, 2. Explicit VR Big Endian, 3. Implicit VR Little Endian

9.1.3.1.3 SOP Specific Conformance Statement - Find SCP

- The Siemens AXIOM Sensis DICOM Query/Retrieve SCP supports hierarchical queries with all mandatory and optional search keys.

The query attribute contents will be treated case-sensitive.

With wildcard queries the symbol "?" is treated as "*" by the C-FIND SCP application. As a consequence the query string of "?abc*" will be processed as "*abc*".

If the value for the patient-level unique key "Patient ID" is not known, it may be returned with zero length. The attribute "Image Comments" will not be include in the C-FIND-RSP, if it is not set in the DB, even if it was requested as return key in the related C-FIND-RQ.

Usage of Storage Media File-Set ID, Retrieve AE Title with C-FIND-RSP message:

- The Storage Media File-Set ID - if existent - can be returned at Study/Series/Instance Level. Only on Instance Level, the values of ONLINE, NEARLINE or OFFLINE are returned to indicate the Storage Location of the related Instance.
- The Retrieve AE Title - if existent - can only be returned at Instance Level (for Patient Root and Study Root models) or Study Level (for Patient/Study Only model).

Relational Queries are not supported.

A remote DICOM AE can cancel the running query by sending a C-FIND-CANCEL. Matches are possibly continuing (more C-FIND response with status PENDING) until the cancel operation has completed.

The supported attributes on the various query levels of the three supported information models are list in the tables of the following sections.

9.1.3.1.3.1 Patient Root Information Model

Attribute Name	Tag	Usage SCU	Matching
Patient Level			
Patient Name	(0010,0010)	R	Single value, Wildcard, universal
Patient ID	(0010,0020)	U	Single Value, Wildcard, universal
Patient's Birth Date	(0010,0030)	O	Single Value, Range, universal
Patient's Birth Time	(0010,0032)	O	Single Value, Range, universal
Patient's Sex	(0010,0040)	O	Single Value, Wildcard, universal
Ethnic Group	(0010,2160)	O	Single Value, Wildcard, universal
Patient Comments	(0010,4000)	O	Wildcard, universal
Number of Patient related Studies	(0020,1200)	O	universal
Number of Patient related Series	(0020,1202)	O	universal
Number of Patient related Instances	(0020,1204)	O	universal
Study Level			
Study Instance UID	(0020,000D)	U	Single Value, List of UIDs
Study ID	(0020,0010)	R	Single Value, Wildcard, universal
Study Date	(0008,0020)	R	Single Value, Range, universal
Study Time	(0008,0030)	R	Single Value, Range, universal
Accession Number	(0008,0050)	R	Single Value, Wildcard,

Attribute Name	Tag	Usage SCU	Matching
			universal
Referring Physician's Name	(0008,0090)	O	Single Value, Wildcard, universal
Study Description	(0008,1030)	O	Single Value, Wildcard, universal
Admitting Diagnosis Description	(0008,1080)	O	Single Value, Wildcard, universal
Patient's Age	(0010,1010)	O	Single Value, Wildcard, universal
Patient's Size	(0010,1020)	O	Single Value, universal
Patient's Weight	(0010,1030)	O	Single Value, universal
Occupation	(0010,2180)	O	Single Value, Wildcard, universal
Additional Patient History	(0010,21B0)	O	Wildcard, universal
Name of Physician reading the Study	(0008,1060)	O	Single Value, Wildcard, universal
Modalities in Study	(0008,0061)	O	Multiple values, universal
Number of Study Related Series	(0020,1206)	O	universal
Number of Study Related Instances	(0020,1208)	O	universal
Series Level			
Series Instance UID	(0020,000E)	U	Single Value, List of UIDs
Series Number	(0020,0011)	R	Single Value, universal
Modality	(0008,0060)	R	Single Value, Wildcard, universal
Laterality	(0020,0060)	O	Single Value, Wildcard, universal
Body Part Examined	(0018,0015)	O	Single Value, Wildcard, universal
Patient Position	(0018,5100)	O	Single Value, Wildcard, universal
Smallest Pixel Value in Series	(0028,0108)	O	Single Value, universal
Largest Pixel Value in Series	(0028,0109)	O	Single Value, universal
Protocol Name	(0018,1030)	O	Single Value, Wildcard, universal
Series Date	(0008,0021)	O	Single Value, Range, universal
Series Time	(0008,0031)	O	Single Value, Range, universal
Series Description	(0008,103E)	O	Single Value, Wildcard, universal
Operator's Name	(0008,1070)	O	Single Value, Wildcard, universal
Performing Physician's name	(0008,1050)	O	Single Value, Wildcard, universal
Performed Procedure Step Start Date	(0040,0244)	O	universal
Performed Procedure Step Start Time	(0040,0245)	O	universal
Number of Series related Instances	(0020,1209)	O	universal
Instance Level			
SOP Instance UID	(0008,0018)	U	Single Value, List of UIDs
Image Number	(0020,0013)	R	Single Value, universal
Image Date	(0008,0023)	O	Single Value, Range, universal
Image Time	(0008,0033)	O	Single Value, Range, universal
Modality	(0008,0060)	O	Single Value, Wildcard, universal
Image Comments	(0020,4000)	O	universal

Supported Query attributes sorted by Query Level – Patient Root Information Model

9.1.3.1.3.2 Study Root Information Model

Attribute Name	Tag	Usage SCU	Matching
Study Level			
Patient Name	(0010,0010)	R	Single value, Wildcard, universal
Patient ID	(0010,0020)	R	Single Value, Wildcard, universal
Patient's Birth Date	(0010,0030)	O	Single Value, Range, universal
Patient's Birth Time	(0010,0032)	O	Single Value, Range, universal
Patient's Sex	(0010,0040)	O	Single Value, Wildcard, universal
Patient Comments	(0010,4000)	O	Wildcard, universal
Number of Patient related Studies	(0020,1200)	O	universal
Number of Patient related Series	(0020,1202)	O	universal
Number of Patient related Instances	(0020,1204)	O	universal
Study Instance UID	(0020,000D)	U	Single Value, List of UIDs
Study ID	(0020,0010)	R	Single Value, Wildcard, universal
Study Date	(0008,0020)	R	Single Value, Range, universal
Study Time	(0008,0030)	R	Single Value, Range, universal
Accession Number	(0008,0050)	R	Single Value, Wildcard, universal
Referring Physician's Name	(0008,0090)	O	Single Value, Wildcard, universal
Study Description	(0008,1030)	O	Single Value, Wildcard, universal
Admitting Diagnosis Description	(0008,1080)	O	Single Value, Wildcard, universal
Patient's Age	(0010,1010)	O	Single Value, Wildcard, universal
Patient's Size	(0010,1020)	O	Single Value, universal
Patient's Weight	(0010,1030)	O	Single Value, universal
Occupation	(0010,2180)	O	Single Value, Wildcard, universal
Additional Patient History	(0010,21B0)	O	Wildcard, universal
Name of Physician reading the Study	(0008,1060)	O	Single Value, Wildcard, universal
Modalities in Study	(0008,0061)	O	Multiple values, universal
Number of Study Related Series	(0020,1206)	O	universal
Number of Study Related Instances	(0020,1208)	O	universal
Series Level			
Series Instance UID	(0020,000E)	U	Single Value, List of UIDs
Series Number	(0020,0011)	R	Single Value, universal
Modality	(0008,0060)	R	Single Value, Wildcard, universal
Laterality	(0020,0060)	O	Single Value, Wildcard, universal
Body Part Examined	(0018,0015)	O	Single Value, Wildcard, universal
Patient Position	(0018,5100)	O	Single Value, Wildcard, universal
Smallest Pixel Value in Series	(0028,0108)	O	Single Value, universal
Largest Pixel Value in Series	(0028,0109)	O	Single Value, universal
Protocol Name	(0018,1030)	O	Single Value, Wildcard, universal
Series Date	(0008,0021)	O	Single Value, Range, universal
Series Time	(0008,0031)	O	Single Value, Range, universal
Series Description	(0008,103E)	O	Single Value, Wildcard, universal

Attribute Name	Tag	Usage SCU	Matching
Operator's Name	(0008,1070)	O	Single Value, Wildcard, universal
Performing Physician's Name	(0008,1050)	O	Single Value, Wildcard, universal
Performed Procedure Step Start Date	(0040,0244)	O	universal
Performed Procedure Step Start Time	(0040,0245)	O	universal
Number of Series related Instances	(0020,1209)	O	universal
Instance Level			
SOP Instance UID	(0008,0018)	U	Single Value, List of UIDs
Image Number	(0020,0013)	R	Single Value, universal
Image Date	(0008,0023)	O	Single Value, Range, universal
Image Time	(0008,0033)	O	Single Value, Range, universal
Modality	(0008,0060)	O	Single Value, Wildcard, universal
Image Comments	(0020,4000)	O	universal

Supported Query attributes sorted by Query Level – Study Root Information Model

9.1.3.1.3.3 Patient/Study Only Information Model

Attribute Name	Tag	Usage SCU	Matching
Patient Level			
Patient Name	(0010,0010)	R	Single value, Wildcard, universal
Patient ID	(0010,0020)	U	Single Value, Wildcard, universal
Patient's Birth Date	(0010,0030)	O	Single Value, Range, universal
Patient's Birth Time	(0010,0032)	O	Single Value, Range, universal
Patient's Sex	(0010,0040)	O	Single Value, Wildcard, universal
Ethnic Group	(0010,2160)	O	Single Value, Wildcard, universal
Patient Comments	(0010,4000)	O	Wildcard, universal
Number of Patient related Studies	(0020,1200)	O	universal
Number of Patient related Series	(0020,1202)	O	universal
Number of Patient related Instances	(0020,1204)	O	universal
Study Level			
Study Instance UID	(0020,000D)	U	Single Value, List of UIDs
Study ID	(0020,0010)	R	Single Value, Wildcard, universal
Study Date	(0008,0020)	R	Single Value, Range, universal
Study Time	(0008,0030)	R	Single Value, Range, universal
Accession Number	(0008,0050)	R	Single Value, Wildcard, universal
Referring Physician's Name	(0008,0090)	O	Single Value, Wildcard, universal
Study Description	(0008,1030)	O	Single Value, Wildcard, universal
Admitting Diagnosis Description	(0008,1080)	O	Single Value, Wildcard, universal
Patient's Age	(0010,1010)	O	Single Value, Wildcard, universal
Patient's Size	(0010,1020)	O	Single Value, universal
Patient's Weight	(0010,1030)	O	Single Value, universal
Occupation	(0010,2180)	O	Single Value, Wildcard, universal
Additional Patient History	(0010,21B0)	O	Wildcard, universal
Name of Physician reading the Study	(0008,1060)	O	Single Value, Wildcard, universal

Attribute Name	Tag	Usage SCU	Matching
Modalities in Study	(0008,0061)	O	Multiple values, universal
Number of Study Related Series	(0020,1206)	O	universal
Number of Study Related Instances	(0020,1208)	O	universal

Supported Query attributes sorted by Query Level – Patient/Study Only Information Model

The Find SCP returns following status codes:

Service Status	Meaning	Error Codes	Related Fields
Refused	Out of Resources	A700	(0000,0902)
Failed	Identifier does not match SOP Class	A900	(0000,0901) (0000,0902)
	Unable to process	C001	(0000,0901) (0000,0902)
Cancel	Matching terminated due to Cancel request	FE00	None
Success	Matching is complete - No final Identifier is supplied	0000	None
Pending	Matches are continuing - Current Match is supplied and any Optional Keys were supported in the same manner as Required Keys	FF00	Identifier
	Matches are continuing - Warning that one or more Optional Keys were not supported for existence and/or matching for this identifier	FF01	Identifier

9.1.3.2 Real-World Activity - Get SCP

9.1.3.2.1 Associated Real-World Activity – Accept Get request to SCP

The associated Real-World activity is to respond to retrieve requests initiated from a foreign SCU. The SCP supports the query model Patient Root, Study Root and Patient/Study Only. The Storage Service Class Conformance Statement describes the C-STORE service which is generated by the C-GET service. Relational retrieve operation is NOT supported.

Multiple C-GET requests over the same association are NOT supported.

9.1.3.2.2 Accepted Presentation Contexts - Get SCP

The Siemens AXIOM Sensis DICOM application will accept Presentation Contexts as shown in the following table:

Presentation Context Table					
Abstract Syntax		Transfer Syntax		Role	Ext. Neg.
Name	UID	Name List	UID List		
Patient Root Query/Retrieve Model – GET	1.2.840.10008.5.1.4.1.2.1.3	Implicit VR Little Endian Explicit VR Little Endian Explicit VR Big Endian	1.2.840.10008.1.2 1.2.840.10008.1.2.1 1.2.840.10008.1.2.2	SCP	None
Study Root Query/Retrieve Model – GET	1.2.840.10008.5.1.4.1.2.2.3	Implicit VR Little Endian Explicit VR Little Endian Explicit VR Big Endian	1.2.840.10008.1.2 1.2.840.10008.1.2.1 1.2.840.10008.1.2.2	SCP	None
Patient/Study Only Query/Retrieve Model – GET	1.2.840.10008.5.1.4.1.2.3.3	Implicit VR Little Endian Explicit VR Little Endian Explicit VR Big Endian	1.2.840.10008.1.2 1.2.840.10008.1.2.1 1.2.840.10008.1.2.2	SCP	None

9.1.3.2.3 SOP Specific Conformance Statement - Get SCP

At association establishment time the C-GET presentation context must be negotiated along with the C-STORE sub-operations which must be accomplished on the same association as the C-GET operation. Relational retrieve operation is NOT supported.

All unique keys have to be supplied according to the selected Query/Retrieve Level. The related tables in the C-FIND SCP section will give information about "U" marked key attributes.

Note: Get operation has to be done for all object instances in order for a study to be complete on the receiver side. Get can not be done from Patient, Study or Series level only.

The Get SCP returns following status codes:

Service Status	Meaning	Error Codes	Related Fields
Refused	Out of Resources - Unable to calculate number of matches	A701	(0000,0902)
	Out of Resources - Unable to perform sub operations	A702	(0000,1020) (0000,1021) (0000,1022) (0000,1023)
Failed	Identifier does not match SOP Class	A900	(0000,0901) (0000,0902)
	Unable to process	C001	(0000,0901) (0000,0902)
Cancel	Sub-operations terminated due to Cancel Indication	FE00	(0000,1020) (0000,1021) (0000,1022) (0000,1023)
Warning	Sub-operations Complete - One or more Failures of Warnings	B000	(0000,1020) (0000,1021) (0000,1022) (0000,1023)
Success	Sub-operations Complete - No Failures or Warning	0000	(0000,1020) (0000,1021) (0000,1022) (0000,1023)
Pending	Sub-operations are continuing	FF00	(0000,1020) (0000,1021) (0000,1022) (0000,1023)

9.1.3.3 Real-World Activity - Move SCP

9.1.3.3.1 Associated Real-World Activity – Accept Move request to SCP

The associated Real-World activity is to respond to retrieve requests to an SCU. The SCP supports the query model Patient Root, Study Root and Patient/Study Only. The Storage Service Class Conformance Statement describes the C-STORE service, which is generated by the C-MOVE service. Relational retrieve operation is NOT supported.

Multiple C-MOVE requests over the same association are NOT supported.

9.1.3.3.2 Accepted Presentation Contexts - Move SCP

The Siemens AXIOM Sensis DICOM application will accept Presentation Contexts as shown in the following table:

Presentation Context Table					
Abstract Syntax		Transfer Syntax		Role	Ext. Neg.
Name	UID	Name List	UID List		
Patient Root Query/Retrieve Model – MOVE	1.2.840.10008.5.1.4.1.2.1.2	Implicit VR Little Endian Explicit VR Little Endian Explicit VR Big Endian	1.2.840.10008.1.2 1.2.840.10008.1.2.1 1.2.840.10008.1.2.2	SCP	None
Study Root Query/Retrieve Model – MOVE	1.2.840.10008.5.1.4.1.2.2.2	Implicit VR Little Endian Explicit VR Little Endian Explicit VR Big Endian	1.2.840.10008.1.2 1.2.840.10008.1.2.1 1.2.840.10008.1.2.2	SCP	None
Patient/Study Only Query/Retrieve Model – MOVE	1.2.840.10008.5.1.4.1.2.3.2	Implicit VR Little Endian Explicit VR Little Endian Explicit VR Big Endian	1.2.840.10008.1.2 1.2.840.10008.1.2.1 1.2.840.10008.1.2.2	SCP	None

9.1.3.3.3 SOP Specific Conformance Statement - Move SCP

At association establishment time the C-MOVE presentation context shall be negotiated. The C-STORE sub-operations is done on a different association, specified in the C-MOVE request, to transfer objects to a remote SCP of the Storage Service Class. Relational retrieve operation is NOT supported.

All unique keys have to be supplied according to the selected Query/Retrieve Level. The related tables in the C-FIND SCP section will give information about "U" marked key attributes.

Note: Move operation has to be done for all object instances in order for the study to be viewed receiver side. Move can not be done from Patient, Study or Series level only.

The Move SCP returns following status codes:

Service Status	Meaning	Error Codes	Related Fields
Refused	Out of Resources - Unable to calculate number of matches	A701	(0000,0902)
	Out of Resources - Unable to perform sub operations	A702	(0000,1020) (0000,1021) (0000,1022) (0000,1023)
Failed	Identifier does not match SOP Class	A900	(0000,0901) (0000,0902)
	Unable to process	C001	(0000,0901) (0000,0902)
Cancel	Sub-operations terminated due to Cancel Indication	FE00	(0000,1020) (0000,1021) (0000,1022) (0000,1023)
Warning	Sub-operations Complete - One or more Failures of Warnings	B000	(0000,1020) (0000,1021) (0000,1022) (0000,1023)
Success	Sub-operations Complete - No Failures or Warning	0000	(0000,1020) (0000,1021) (0000,1022) (0000,1023)
Pending	Sub-operations are continuing	FF00	(0000,1020) (0000,1021) (0000,1022) (0000,1023)

10 Implementation Model Worklist

The Basic Worklist Management Service class defines an application-level class of service, which facilitates the transfer of worklists from the information system to the imaging modality. The worklist is queried by the AE and supplies the SCU with the scheduled tasks, which have to be performed on the modality. The AXIOM Sensis DICOM worklist application supports the worklist service as SCU.

10.1 Application Data Flow Diagram

The AXIOM Sensis DICOM network implementation is a Windows 2000 application and acts as SCU for the Basic Worklist Service using the Modality Worklist SOP Class.

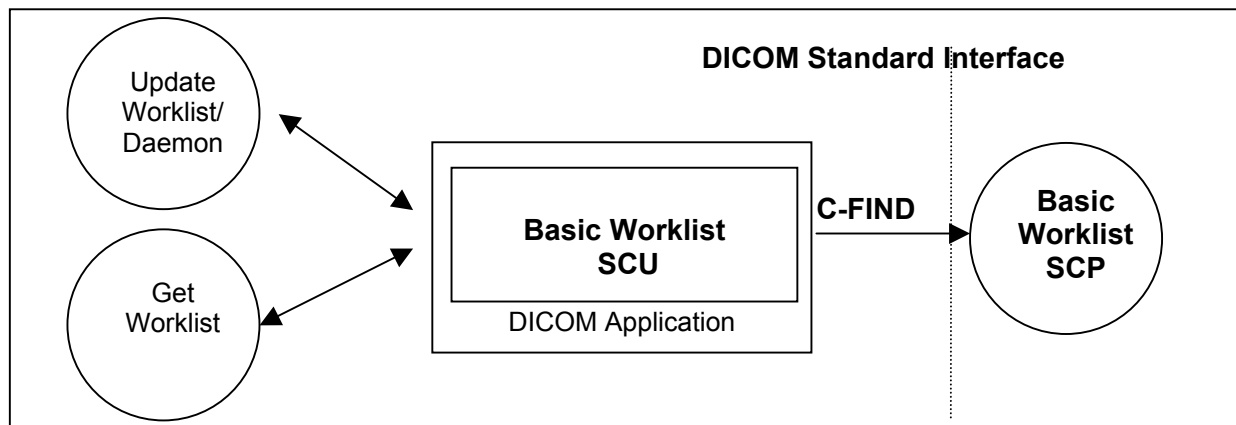

Figure 6: AXIOM Sensis Application Flow Diagram – Basic Worklist SCU

10.2 Functional Definitions of Application Entities

The worklist SCU ("broad query") is invoked from the patient browser user interface or by timer to request the worklist from an remote Information System (Modality Worklist Class SCP) to perform a match to the internal worklist query keys specified in the C-Find DIMSE service issued for the Modality Worklist Model.

The worklist SCP responses to the C-FIND query and scheduled imaging service requests (scheduled procedure steps) and patient demographic information will be downloaded from the information system to the <product> modality. All information retrieved will be hold in the scheduling database for usage during Patient registration procedure.

Furthermore, during Patient Registration dialog, it is possible to update/complete the entered data by a "Get Worklist" function. Some of the entered data will then be used as matching criteria ("narrow query") for the issue worklist query. With the response data then the Patient Registration dialog fields are populated according availability within the worklist response identifier.

10.3 Sequencing of Real-World Activities

The "narrow" (interactive) Worklist Query requires that sufficient matching keys or a unique matching key are/is entered before the query is issued. Only then a single response can be expected to complete the registration dialog.

11 Application Entity Specification Worklist

11.1 Modality Worklist Service AE Specification

The Modality worklist SCU (patient registration in conjunction with the network application) requests that the remote SCP performs a match of all keys specified in the query against the information in its worklist database.

The SIEMENS AXIOM Sensis DICOM network implementation is a Windows 2000 application and acts as SCU for the Basic Worklist Service using the Modality Worklist SOP Class:

SOP Class Name	SOP Class UID
Modality Worklist Information Model - FIND	1.2.840.10008.5.1.4.31

11.1.1 Association Establishment Policies

11.1.1.1 General

There will be a cyclic update of the modality scheduler database by background worklist request with date/time and modality information.

In addition the user can request worklist update with "Update Worklist". The modality will not insert duplicate entries identified by unique identifiers.

An interactive worklist query can be issued with search criteria entered during patient registration.

The default PDU size used will be 28 KB.

SIEMENS AXIOM Sensis application does not handle several Scheduled Procedure Steps for one Requested Procedure. If several Scheduled Procedure Steps are requested for one patient they have to be in different Requested Procedures (separate Study Instance UIDs).

11.1.1.2 Number of Associations

The Siemens AXIOM Sensis DICOM application initiates one association at a time to query worklist entry data.

11.1.1.3 Asynchronous Nature

The Siemens AXIOM Sensis DICOM software does not support asynchronous communication (multiple outstanding transactions over a single association).

11.1.1.4 Implementation Identifying Information

Implementation Class UID	1.3.12.2.1107.5.9.20000101
Implementation Version Name	"SIEMENS_SWFVC10E"

11.1.2 Association Initiation Policy

The network application will cyclically query the worklist and by request of patient registration interface. Ever then it establishes an association by using the DICOM association services. During association establishment the negotiation of SOP classes to exchange the capabilities of the SCU and the SCP is not supported.

The following DIMSE-C operation is supported as SCU:

- C-FIND

11.1.2.1 Real-World Activity

11.1.2.1.1 Associated Real-World Activity - Query (Update) Worklist

A network application will perform worklist queries with the C-FIND request at regular intervals. In addition it can be triggered by immediate request. The received worklist items will be compared with the contents of the local scheduler database. New items will be inserted into scheduler database.

11.1.2.1.2 Proposed Presentation Contexts

The Siemens AXIOM Sensis DICOM application will propose Presentation Contexts as shown in the following table:

Presentation Context Table					
Abstract Syntax		Transfer Syntax		Role	Ext. Neg.
Name	UID	Name List	UID List		
Modality Worklist Information Model- FIND	1.2.840.10008.5.1.4.31	Implicit VR Little Endian Explicit VR Little Endian Explicit VR Big Endian	1.2.840.10008.1.2 1.2.840.10008.1.2.1 1.2.840.10008.1.2.2	SCU	None

11.1.2.1.3 SOP Specific Conformance Statement

Search Key Attributes of the Worklist C-FIND

The Siemens AXIOM Sensis DICOM worklist SCU supports “broad worklist queries” with all required search keys. The following tables describe the “broad query” search keys that the SCU supports.

Attribute Name	Tag	Matching Key Type	Query Value
Scheduled Procedure Step Sequence	(0040,0100)	R	
>Scheduled Station AE Title	(0040,0001)	R	<own AET> or “*” ⁴
>Scheduled Procedure Step Start Date	(0040,0002)	R	<act. Date>-<act. Date> or range from UI ⁵
>Scheduled Procedure Step Start Time	(0040,0003)	R	<zero length> or range from UI ^p

⁴ This depends on user configuration (Options->Configuration->Patient Registration) if the "own AET" is provided or not. Use the "Search" tabcard and (un-)check the "Worklist for Local/Modality" item.

⁵ It depends on user configuration (Options->Configuration->Patient Registration) if the actual Date with a full time range or an interactive input dialog for date/time specification is used.

Attribute Name	Tag	Matching Key Type	Query Value
>Modality	(0008,0060)	R	"*" or <own Modality> ^a
>Scheduled Performing Physician's Name	(0040,0006)	R	NULL

Return Key Attributes of the Worklist C-FIND

The Siemens AXIOM Sensis DICOM worklist SCU supports worklist queries with return key attributes of all types. The following tables describe the return keys that the SCU supports.

Note: Wildcard characters (* and?) are not supported in any return key attribute.

An "x" in the **UI** column will indicate the attribute is visualized when browsing the Worklist results with Patient Browser and/or during Patient Registration. The Patient Browser display is additionally influenced by the related Browser configuration.

An "x" in the **IOD** column will indicate that the related attribute is included into the SOP Instances of the IOD's created during processing of this worklist request.

Note: For SIEMENS Word.Report XA image (see Appendix) some Worklist attributes will not be copied .

Attribute Name	Tag	Return Key Type	UI	IOD
SOP Common				
Specific Character Set	(0008,0005)	1C	-	x
Scheduled Procedure Step				
Scheduled Procedure Step Sequence	(0040,0100)	1		
>Scheduled Station AE Title	(0040,0001)	1	x	
>Scheduled Procedure Step Start Date	(0040,0002)	1	x	
>Scheduled Procedure Step Start Time	(0040,0003)	1	x	
>Scheduled Procedure Step End Date	(0040,0004)	3	-	
>Scheduled Procedure Step End Time	(0040,0005)	3	-	
>Modality	(0008,0060)	1	x	x
>Scheduled Performing Physician's Name	(0040,0006)	1	x	x ^b
>Scheduled Procedure Step Description	(0040,0007)	1C	x	
>Scheduled Station Name	(0040,0010)	2	x	
>Scheduled Procedure Step Location	(0040,0011)	2	x	
>Scheduled Action Item Code Sequence	(0040,0008)	1C	-	
>>Code Value	(0008,0100)	1C	x	
>>Coding Scheme Designator	(0008,0102)	1C	x	
>>Code Meaning	(0008,0104)	3	x	
>Pre-Medication	(0040,0012)	2C	x	
>Scheduled Procedure Step ID	(0040,0009)	1	x	x
>Requested Contrast Agent	(0032,1070)	2C	x	x
>Comments on the Scheduled Procedure Step	(0040,0400)	3	-	
Requested Procedure				
Requested Procedure ID	(0040,1001)	1	x	x
Requested Procedure Description	(0032,1060)	1C	x	x ^b
Requested Procedure Code Sequence	(0032,1064)	1C	-	
>Code Value	(0008,0100)	1C	x	
>Coding Scheme Designator	(0008,0102)	1C	x	
>Code Meaning	(0008,0104)	3	x	
Study Instance UID	(0020,000D)	1	x	x

Attribute Name	Tag	Return Key Type	UI	IOD
Referenced Study Sequence	(0008,1110)	2	-	
>Referenced SOP Class UID	(0008,1150)	1C	-	
>Referenced SOP Instance UID	(0008,1155)	1C	-	
Requested Procedure Priority	(0040,1003)	2	x	
Patient Transport Arrangements	(0040,1004)	2	-	
Reason for the Requested Procedure	(0040,1002)	3	-	
Placer Order Number / Procedure	(0040,1006)	3	-	
Filler Order Number / Procedure	(0040,1007)	3	-	
Confidentiality Code	(0040,1008)	3	-	
Reporting Priority	(0040,1009)	3	-	
Names of intended Recipients of Results	(0040,1010)	3	-	
Requested Procedure Comments	(0040,1400)	3	x	
Requested Procedure Location	(0040,1005)	3	-	
Imaging Service Request				
Accession Number	(0008,0050)	2	x	x
Requesting Physician	(0032,1032)	2	x	x
Referring Physician's Name	(0008,0090)	2	x	x
Reason for Imaging Service Request	(0040,2001)	3	-	
Imaging Service Request Comments	(0040,2400)	3	x	
Requesting Service	(0032,1033)	3	x	
Issuing Date of Imaging Service Request	(0040,2004)	3	-	
Issuing Time of Imaging Service Request	(0040,2005)	3	-	
Placer Order Number / Imaging Service Request	(0040,2006)	3	-	
Filler Order Number / Imaging Service Request	(0040,2007)	3	-	
Order entered by ...	(0040,2008)	3	-	
Order Enterer's location	(0040,2009)	3	-	
Order Callback Number	(0040,2010)	3	-	
Visit Identification				
Admission ID	(0038,0010)	2	x	
Issuer of Admission ID	(0038,0011)	3	-	
Visit Status				
Current Patient Location	(0038,0300)	2	x	
Visit Relationship				
Referenced Patient Sequence	(0008,1120)	2	-	
>Referenced SOP Class UID	(0008,1150)	1C	-	
>Referenced SOP Instance UID	(0008,1155)	1C	-	
Visit Admission				
Institution Name	(0008,0080)	3	x	
Admitting Diagnosis Description	(0008,1080)	3	x	
Patient Identification				
Patient's Name	(0010,0010)	1	x	x
Patient ID	(0010,0020)	1	x	x
Patient Demographic				
Patient's Birth Date	(0010,0030)	2	x	x
Patient's Sex	(0010,0040)	2	x	x
Patient's Weight	(0010,1030)	2	x	x
Confidential constraint on patient data	(0040,3001)	2	x	x
Patient's Address	(0010,1040)	3	x	
Military Rank	(0010,1080)	3	x	
Ethnic Group	(0010,2160)	3	x	
Patient Comment	(0010,4000)	3	x	
Patient Medical				
Patient State	(0038,0500)	2	x	x

Attribute Name	Tag	Return Key Type	UI	IOD
Pregnancy Status	(0010,21C0)	2	x	
Medical Alerts	(0010,2000)	2	x	x
Contrast Allergies	(0010,2110)	2	x	x
Special Needs	(0038,0050)	2	-	x
Smoking Status	(0010,21A0)	3	x	
Last Menstrual Date	(0010,21D0)	3	x	
Additional Patient History	(0010,21B0)	3	x	

¹ "Scheduled Performing Physician's Name" is taken as default for "Performing Physicians's Name"

^b "Requested Procedure Description" is taken as default for "Study Description" in IOD if a match is found with local list of study descriptions. E.g. to match the Study Type "Coronary^Coronary Cardiac Catheterization" the Requested Procedure Description has to be "Coronary^Coronary Cardiac Catheterization" i.e. both the category "Coronary" and the "^" sign have to be present.

11.1.2.1.4 Associated Real-World Activity – Get Worklist

With "Get Worklist" the contents of certain input fields of the Patient Registration UI are used to form a worklist request identifier. With the response data the Patient Registration dialog input is completed. The response data are additionally placed in the scheduler database.

11.1.2.1.5 Proposed Presentation Contexts – Get Worklist

This RWE will propose the same Presentation Contexts as with "Update Worklist". Please see table in section 9.1.2.1.2.

11.1.2.1.6 SOP Specific Conformance – Get Worklist

Search Key Attributes of the Worklist C-FIND

The Siemens AXIOM Sensis DICOM worklist SCU supports "narrow worklist queries" with all required search keys. The following tables describe the "narrow query" search keys that the SCU supports.

Attribute Name	Tag	Matching Key Type	Query Value
Scheduled Procedure Step			
Scheduled Procedure Step Sequence	(0040,0100)	R	
>Scheduled Performing Physician's Name	(0040,0006)	R	input from UI or <zero length>
Requested Procedure			
Requested Procedure ID	(0040,1001)	O	input from UI or <zero length>
Imaging Service Request			
Accession Number	(0008,0050)	O	input from UI or <zero length>
Referring Physician's Name	(0008,0090)	O	input from UI or <zero length>
Visit Status			
Current Patient Location	(0038,0300)	O	input from UI or <zero length>
Patient Identification			
Patient's Name	(0010,0010)	R	input from UI or <zero length>
Patient ID	(0010,0020)	R	input from UI or <zero length>

Return Key Attributes of the Worklist C-FIND

Please see list for "Update Worklist" RWE.

Status Codes of the Worklist C-FIND

The worklist SCU interprets following status codes:

Service Status	Meaning	Error Codes	Related Fields
Refused	Out of Resources	A700	(0000,0902)
Failed	Identifier does not match SOP Class	A900	(0000,0901) (0000,0902)
	Unable to process	Cxxx	(0000,0901) (0000,0902)
Cancel	Matching terminated due to Cancel request	FE00	None
Success	Matching is complete - No final Identifier is supplied	0000	None
Pending	Matches are continuing - Current Match is supplied and any Optional Keys were supported in the same manner as Required Keys	FF00	Identifier
	Matches are continuing - Warning that one or more Optional Keys were not supported for existence and/or matching for this identifier	FF01	Identifier

12 Communication Profiles

12.1 Supported Communication Stacks

The Siemens AXIOM Sensis DICOM application provides DICOM V3.0 TCP/IP Network Communication Support as defined in Part 8 of the DICOM Standard.

12.1.1 OSI Stack

Not supported

12.1.2 TCP/IP Stack

The Siemens AXIOM Sensis DICOM application uses the TCP/IP stack from the Windows 2000 system upon which it executes. It uses the MergeCOM-3 subroutine library from Merge Technologies Inc. that is based on a Berkeley socket interface.

12.1.2.1 API

The Siemens AXIOM Sensis DICOM application uses the MergeCOM library that is based on a TCP/IP socket interface.

12.1.2.2 Physical Media Support

The Siemens AXIOM Sensis DICOM application is indifferent to the physical medium over which TCP/IP executes; it inherits this from the Windows 2000 system upon which it executes.

12.1.3 Point-to-Point Stack

Not supported

13 Extensions / Specializations / Privatizations

13.1.1 Standard Extended / Specialized / Private SOPs

Please refer to Appendix for all information on these topics. A detailed overview is given there.

13.1.2 Private Transfer Syntaxes

Not applicable

14 Configuration

14.1 AE Title/Presentation Address Mapping

To ensure unique identification within the network the hostname should be used as part of the AE Titles (see examples below, hostname = SensisCA1). The string can be up to 16 characters long and must not contain any extended characters, only 7-bit ASCII characters (excluding Control Characters) are allowed according to DICOM Standard.

14.1.1 DICOM Verification

The Verification Service uses the AE configuration of the DICOM Service that is checked with the C-ECHO message. e.g. Verification will use the Storage AE, if initiated to check the configuration of a remote DICOM node.

14.1.2 DICOM Storage AE Title

The DICOM Storage application provides the application entity title, which can be configured via Service UI:

e.g. STU_SensisCA1

The port number is set to the fixed value of

104

14.1.3 DICOM Query/Retrieve AE Title

The DICOM Query/Retrieve application uses the same application entity title as the DICOM Storage AE.

14.1.4 DICOM Modality Worklist AE Title

The DICOM Modality Worklist application provides the application entity title:

e.g. HRI_SensisCA1

The port number is set to the fixed value of

106

14.2 Configurable Parameters

The Application Entity Titles, host names and port numbers are configured using the Siemens AXIOM Sensis Service/Installation Tool. For each AET the list of services supported can be configured.

14.2.1 Storage and Query/Retrieve

The Siemens AXIOM Sensis Service/Installation Tool can be used to set the AET's, port-numbers, host-names, IP-addresses and capabilities for the remote nodes (SCP's). The user can select transfer syntaxes, compression modes and query models for each SCP separately.

14.2.2 Worklist

The Siemens AXIOM Sensis Service/Installation Tool can be used to configure the SCP (Worklist Provider). The AET, host-name, IP-address, port-number and time-outs can be set.

Additional configurable parameters for Basic Worklist Service are:

- *Query Waiting Time* - the time to wait for the C-FIND-RSP after sending the C-FIND-RQ (default 20s)
- *Max Query Match Number* – the maximum number of entries accepted as worklist response (default is 200)
- *Query Interval* - the time between two cyclic C-FIND-RQ to the HIS (default is 60 min)
- Broad Worklist Query behaviour: two values are defined:
 - Set the AE Title search attribute to the own AE Title, and the Modality search attribute to "x"
 - Set the Modality search attribute to the own modality and the AE Title search attribute to "x"

14.3 Default Parameters

This installation tool also uses some default parameters:

- max PDU size set to 28672 Bytes (28 kB)
- time-out for accepting/rejecting an association request: 240 s
- time-out for responding to an association open/close request: 240 s
- time-out for accepting a message over network: 240 s
- time-out for waiting for data between TCP/IP-packets: 240 s

The time-outs for waiting for a Service Request/Response message from the remote node are as follows:

- for Storage SCP/SCU: 600 s
- for Query/Retrieve SCP/SCU: 600 s
- for Basic Worklist SCU; configurable, see section 12.2.2

15 Support of Extended Character Sets

The Siemens AXIOM Sensis DICOM application supports the ISO 8859 Latin 1 (ISO-IR 100) and ISO-IR6 character sets.

Also the Japanese language character sets JIS X 0201 (ISO-IR 13 Japanese katakana and ISO-IR 14 Japanese romaji), JIS X 0208 (ISO-IR 87 Japanese kanji) and JIS X 0212 (IOS-IR 159 Supplementary Japanese kanji) are supported in the DICOM interfaces but will not be correctly represented in the generated reports

When there is a mismatch between the SCS tags (0008,0005) and the characters in an IOD received by the system, then the following measures are taken to make the characters DICOM con-form:

Try to import with ISO_IR 100. If ISO_IR 100 fails, convert each illegal character to a '?'.

Application Profile Conformance Statement

This chapter will contain the Conformance Statement to all "Offline Media Application Profiles (incl. private extensions)" supported by the AXIOM Sensis archive options.

Those application profiles supported shall be:

- Basic Cardiac
- 1024 Extended Cardiac
- General Purpose CDR
- Private Extended Syngo Profile

16 Introduction

16.1 Purpose

This DICOM Conformance Statement is written according to part PS 3.2 of [1].

The applications described in this conformance statement are the SIEMENS Angiographic/Radiographic Workstation (AXIOM Sensis) based products using the AXIOM Sensis software. The AXIOM Sensis DICOM offline media storage service implementation acts as FSC, FSU and/or FSR for the specified application profiles and the related SOP Class instances.

16.2 Scope

This DICOM Conformance Statement refers to SIEMENS AXIOM Sensis based products using AXIOM Sensis software. The following table relates AXIOM Sensis software names to SIEMENS products:

Software Name	SIEMENS AXIOM Sensis Product
VC00A/B	AXIOM Sensis

16.3 Definitions, Abbreviations

16.3.1 Definitions

DICOM	Digital Imaging and Communications in Medicine
DIMSE	DICOM Message Service Element
DIMSE-C	DICOM Message Service Element with Composite information objects

16.3.2 Abbreviations

ACR	American College of Radiology
AE	DICOM Application Entity
ASCII	American Standard Code for Information Interchange
AXIOM Sensis	AX-Workstation (for Angiographic/Radiographic viewing)
DB	Database
DCS	DICOM Conformance Statement
FSC	File Set Creator
FSR	File Set Reader
FSU	File Set Updater
IOD	DICOM Information Object Definition
ISO	International Standard Organization
MOD	Magneto-optical Disk
NEMA	National Electrical Manufacturers Association
O	Optional Key Attribute
PDU	DICOM Protocol Data Unit
R	Required Key Attribute
RWA	Real-World Activity
U	Unique Key Attribute

16.4 References

[1] Digital Imaging and Communications in Medicine (DICOM) 3.0, NEMA PS 3.1-12, 1999

16.5 Remarks

DICOM, by itself, does not guarantee interoperability. However, the Conformance Statement facilitates a first-level validation for interoperability between different applications supporting the same DICOM functionality as SCU and SCP, respectively.

This Conformance Statement is not intended to replace validation with other DICOM equipment to ensure proper exchange of information intended.

The scope of this Conformance Statement is to facilitate communication with Siemens and other vendors' Medical equipment. The Conformance Statement should be read and understood in conjunction with the DICOM 3.0 Standard [DICOM]. However, by itself it is not guaranteed to ensure the desired interoperability and a successful interconnectivity.

The user should be aware of the following important issues:

- The comparison of different conformance statements is the first step towards assessing interconnectivity between Siemens and non-Siemens equipment.
- Test procedures should be defined and tests should be performed by the user to validate the connectivity desired. DICOM itself and the conformance parts do not specify this.
- The standard will evolve to meet the users' future requirements. Siemens is actively involved in developing the standard further and therefore reserves the right to make changes to its products or to discontinue its delivery.
- Siemens reserves the right to modify the design and specifications contained herein without prior notice. Please contact your local Siemens representative for the most recent product information.

17 Implementation Model

17.1 Application Data Flow Diagram

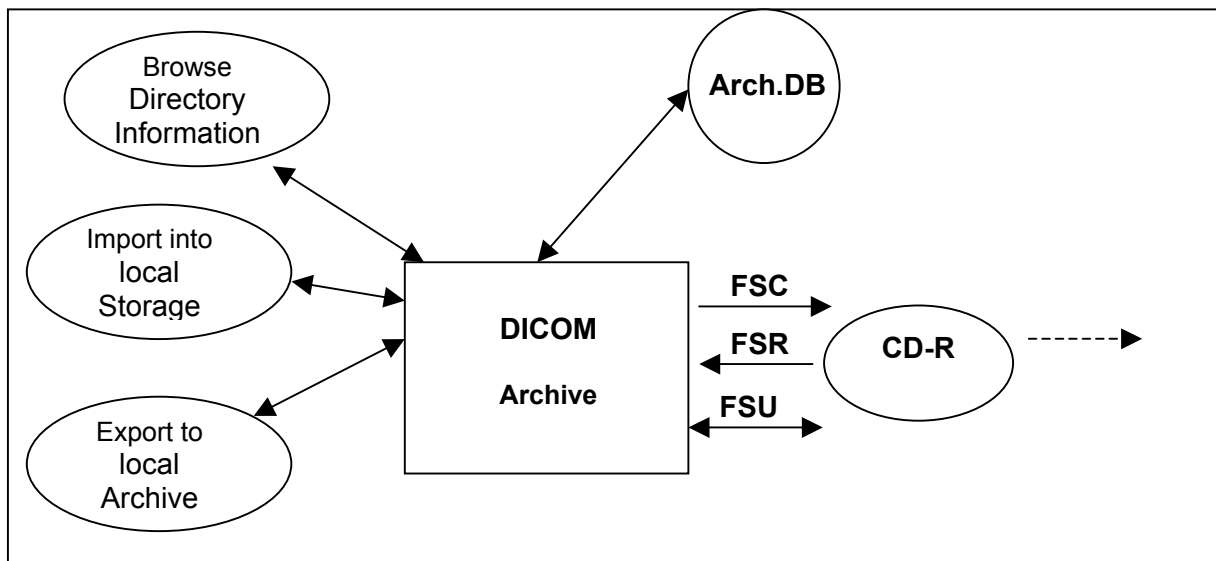

The DICOM archive application will serve as an interface to the CD-R offline medium device. It serves interfaces to include the offline media directory into the browser and to copy SOP instances to a medium or retrieve SOP Instances from medium into local storage.

The DICOM Archive application will support the 120mm CD-R medium.

The FSU role will update new SOP Instances only to media with pre-existing File-sets conforming to the Application Profiles supported.

The contents of the DICOMDIR will be temporarily stored in Archive-Database.

17.2 Functional Definitions of AEs

The AXIOM Sensis DICOM offline media storage application consists of the DICOM Archive application entity serving all interfaces to access offline media. The DICOM Archive application is capable of

1. creating a new File-set onto an unwritten medium (Export to...).
2. updating an existing File-set by writing new SOP Instances onto the medium (Export to...).
3. importing SOP Instances from the medium onto local storage
4. reading the File-sets DICOMDIR information into temporary database and pass it to display applications.

17.3 Sequencing of Real-World Activities

The DICOM Archive application will not perform updates before the Directory information of the DICOMDIR is completely read.

When performing updates, the SOP instances are checked for existence before updating. Duplicate instances will be avoided.

17.4 File Meta Information Options

Implementation Class UID	1.3.12.2.1107.5.9.20000101
Implementation Version Name	"SIEMENS_SWFVC10E"

18 AE Specifications

18.1 DICOM Archive Specification

The DICOM Archive provides Standard conformance to Media Storage Service Class (Interchange Option). In addition Augmented conformance is provided to store extra data attributes important for the full feature support of the AXIOM Sensis product SW. Details are listed in following Table:

Application Profiles Supported	Real-World Activity	Role	SC Option
AUG-XA1K-CD *1 STD-GEN-CD PRI-XAMAS-CD PRI-SYNGO-CD STD-GEN-MOD PRI-SYNGO-MOD	Browse Directory Information	FSR	Interchange
	Import into local Storage	FSR	Interchange
	Export to local Archive Media	FSC, FSU	Interchange
STD-GEN-CD STD-XABC-CD STD-XA1K-CD STD-GEN_MOD PRI-SYNGO-MOD	Browse Directory Information	FSR	Interchange
	Import into local Storage	FSR	Interchange

*1 – With no Private SOP Class used, the PRI-XAMAS-CD profile definitions are appropriate to describe the augmentation of the STD-XA1K-CD Profile.

On AXIOM Sensis based Systems, the Private Extended Syngo Profiles (PRI-SYNGO-CD, PRI-SYNGO-MOD) will be preferably used by the system. The General Purpose Interchange Profile (STD-GEN-CD, STD-GEN-MOD), Basic Cardiac Profile (STD-XABC-CD) and 1024 X-Ray Angiographic Profile (STD-XA1K-CD) will be supported with read, write, and update capability of the related media.

For MOD profiles the same rules apply as for CD profiles.

18.1.1 File Meta Information for the Application Entity

The Source Application Entity Title is set by configuration. See Chapter "Configuration" for details.

18.1.2 Real-World Activities for this Application Entity

18.1.2.1 Real-World Activity: Browse Directory Information

The DICOM Archive application acts as FSR using the interchange option when requested to read the media directory.

The DICOM archive application will read the DICOMDIR and insert those directory entries, that are valid for the application profiles supported, into a local database. The database can then be used for browsing media contents.

Note

IconImageSQ is also supported in DICOMDIR. But only those Icon Images with BitsAllocated (0028,0100) equal to 8 and size of 64x64 or 128x128 pixels are imported into database and are visible in the Browser.

18.1.2.1.1 Application Profiles for the RWA: Browse Directory Information

See Table in section 3.1 for the Application Profiles listed that invoke this Application Entity for the Browse Directory Information RWA.

18.1.2.2 Real-World Activity: Import into local Storage

The DICOM Archive application acts as FSR using the interchange option when requested to read SOP Instances from the medium into the local storage.

The SOP Instance selected from the media directory will be copied into the local storage. All SOP Instances, that are valid for the application profile supported can be retrieved from media storage, but only those listed as supported by the Storage SCP Conformance section (Network DCS, 5.1.3) will be handled by the application.

During operation no "Attribute Value Precedence" is applied to the SOP Instances. Detached Patient Management is not supported.

For media conforming to the STD-GEN-CD Profile the following SOP classes will be supported as an FSR:

Information Object Definition	SOP Class UID	Transfer Syntax UID
X-Ray Angiographic Image	1.2.840.10008.5.1.4.1.1.12.1	Explicit VR Little Endian Uncompressed 1.2.840.10008.1.2.1
Cardiac Electrophysiology Waveform Storage SOP Class	1.2.840.10008.5.1.4.1.1.9.3.1	Explicit VR Little Endian 1.2.840.10008.1.2.1
CSA Non-Image	1.3.12.2.1107.5.9.1	Explicit VR Little Endian Uncompressed 1.2.840.10008.1.2.1

18.1.2.2.1 Application Profiles for the RWA: Import into local Storage

See Table in section 3.1 for the Application Profiles listed that invoke this Application Entity for the Import into Local Storage RWA.

18.1.2.3 Real-World Activity: Export to local Archive Media

The DICOM Archive application acts as FSU (for media with existing DICOM file-set) or FSC (media not initialized) using the interchange option when requested to copy SOP Instances from the local storage to local Archive Medium.

The DICOM Archive application will receive a list of SOP Instances to be copied to the local archive medium. According to the state of the medium inserted (new medium, Medium with DICOM file-set) the validity of the SOP Instances according to the applicable profile is checked. Only valid SOP Instances are accepted.

When the DICOM archive application is requested to copy SOP Instances the preferred application profile according configuration (AUG-XA1K-CD or PRI-XAMAS-CD) will be used to validate and copy the referred SOP Instances. When creating a new file-set no Descriptor File will be allocated and the related ID is not used.

The DICOM archive application will not close the medium.

18.1.2.3.1 Application Profiles for the RWA: Export to local Archive Media

See Table in section 3.1 for the Application Profiles listed that invoke this Application Entity for the Export to local Archive Media RWA.

19 Augmented and Private Profiles

19.1 Augmented Application Profiles

19.1.1 AUG-XA1K-CD

With no private Siemens Non-Images stored onto Medium, the definitions of the PRI-XAMAS-CD Profile are applicable to denote the augmentations for the STD-XA1K-CD Standard Profile.

Storage of Private Information Objects will only be supported with reference to a Private Application Profile (see next section).

19.2 Private Application Profiles

19.2.1 PRI-XAMAS-CD

The DICOM Archive application is conforming to the PRI-XAMAS application profile class provided in a separate document. Please refer to next section for more information on specializations and extensions in accordance to this Application Profile.

20 Extensions, Specializations and Privatizations of SOP Classes and Transfer Syntaxes

The SOP Classes listed refer in majority to those created by the equipment to which this conformance Statement is related to. For SOP classes not listed in this section, please refer to the Storage section of the DICOM Conformance Statement of the product. This will include all SOP Instances that can be received and displayed and therefore will be included into offline media storage even though these SOP Instances are not created by the equipment serving the Media Storage Service.

20.1 Physical Media and Formats

The PRI-SYNGO-CD Profile requires the 120mm CD-R physical media with the ISO/IEC 9660 Media Format, as defined in PS3.12.

The PRI-SYNGO-MOD23 Profile requires the 130mm 2.3 GB R/W MOD physical medium with the PCDOS Media Format, as defined in PS3.12.

The PRI-SYNGO-MOD41 Profile requires the 130mm 4.1 GB R/W MOD physical medium with the PCDOS Media Format, as approved by DICOM Suppl. 62.

20.2 Directory Information in DICOMDIR

Conforming Application Entities shall include in the DICOMDIR File the Basic Directory IOD containing Directory Records at the Patient and subsidiary levels appropriate to the SOP Classes in the File-set. All DICOM files in the File-set incorporating SOP Instances defined for the specific Application profile, shall be referenced by Directory Records.

Note

DICOMDIRs with no directory information are not allowed by this Application Profile

Privately defined IODs will be referenced by "PRIVATE" Directory Records.

20.2.1 Additional Keys

File-set Creators and Updaters are required to generate the mandatory elements specified in PS 3.3, Annex F of the DICOM Standard. Table 3:PRI-SYNGO-CD Additional DICOMDIR Keys specifies the additional associated keys. At each directory record level other additional data elements can be added, but it is not required that File Set Readers be able to use them as keys. Refer to the Basic Directory IOD in PS 3.3.

Key Attribute	Tag	Directory Record Level	Type	Notes
Date of Birth	(0010,0030)	PATIENT	2C	required, if present in SOP Instance
Patient's Sex	(0010,0040)	PATIENT	2C	required, if present in SOP Instance
Series Date	(0008,0021)	SERIES	3	
Series Time	(0008,0031)	SERIES	3	
Institute Name	(0008,0080)	SERIES	2C	required, if present in SOP Instance
Institution Address	(0008,0081)	SERIES	2C	required, if present in SOP Instance
Series Description	(0008,103E)	SERIES	3	
Performing Physician's Name	(0008,1050)	SERIES	2C	required, if present in SOP Instance
Image Type	(0008,0008)	IMAGE	1C	required, if present in SOP Instance
SOP Class UID	(0008,0016)	IMAGE	3	
SOP Instance UID	(0008,0018)	IMAGE	3	
Image Date	(0008,0023)	IMAGE	3	
Image Time	(0008,0033)	IMAGE	3	
Referenced Image Sequence	(0008,1140)	IMAGE	1C	required, if present in SOP Instance
> Referenced SOP Class UID	(0008,1150)			
> Referenced SOP Instance UID	(0008,1155)			
Image Position (Patient)	(0020,0032)	IMAGE	2C	required, if present in SOP Instance
Image Orientation (Patient)	(0020,0037)	IMAGE	2C	required, if present in SOP Instance
Frame of Reference UID	(0020,0052)	IMAGE	2C	required, if present in SOP Instance
Rows	(0028,0010)	IMAGE	3	
Columns	(0028,0011)	IMAGE	3	
Pixel Spacing	(0028,0030)	IMAGE	1C	required, if present in SOP Instance
Calibration Image	(0050,0004)	IMAGE	2C	required, if present in SOP Instance
Icon Image Sequence	(0088,0200)	IMAGE	3	Required for Image SOP Classes
> Samples per Pixel	(0028,0002)			1
> Photometric Interpretation	(0028,0004)			MONOCHROME2
> Rows	(0028,0010)			128 for XA, 64 for others
> Columns	(0028,0011)			128 for XA, 64 for others
> Bits Allocated	(0028,0100)			8
> Bits Stored	(0028,0101)			8
> High Bit	(0028,0102)			7
> Pixel Representation	(0028,0103)			0
> Pixel Data	(7FE0,0010)			Icon Image

20.2.2 Private Directory Record Keys

Private Directory Records are supported by this Application Profile Class at the following Level - IMAGE. The PRIVATE Directory Records will have required elements in addition to the mandatory elements specified in PS 3.3.

The following table will list the additional required keys for PRIVATE Directory Records:

Key Attribute	Tag	Directory Record Level	Type	Notes
Private Record UID	(0004,1432)	PRIVATE	1	See Conformance Statement
SOP Class UID	(0008,0016)	PRIVATE	1C	required, if present in SOP Instance
SOP Instance UID	(0008,0018)	PRIVATE	1C	required, if present in SOP Instance
Image Type	(0008,0008)	PRIVATE	3	
Acquisition Date	(0008,0022)	PRIVATE	3	
Acquisition Time	(0008,0032)	PRIVATE	3	
Acquisition Number	(0020,0012)	PRIVATE	3	
CSA Data Type	(0029,xx08)	PRIVATE	1	private owner code = SIEMENS CSA NON-IMAGE
CSA Data Version	(0029,xx09)	PRIVATE	3	private owner code = SIEMENS CSA NON-IMAGE

20.2.3 Icon Images

Directory Records of type SERIES or IMAGE may include Icon Images. The Icon Image pixel data shall be as specified in PS 3.3 "Icon Image Key Definition", and restricted such, that Bits Allocated (0028,0100) and Bits Stored (0028,0101) shall be equal 8, and Rows (0028,0010) and Columns (0028,0011) shall be equal to 128 for XA Images and 64 for all other Images. The Photometric Interpretation (0028,0004) shall always be restricted to "MONOCHROME2".

PRIVATE Directory Records will not contain Icon Image information.

20.3 SOP Specific Conformance Statement for Basic Directory

20.3.1 Extension, Specialization for SIEMENS Non-Image Objects

According to the PRI-XAMAS Application Profile Class the usage of the Private Creator UIDs and further optional keys for the Directory Records referring to SIEMENS Non-Image Objects are listed in the following tables.

Attribute	Tag	Value used
Private Record UID	(0004,1432)	1.3.12.2.1107.5.9.1
SOP Class UID	(0008,0016)	1.3.12.2.1107.5.9.1

For those "Non-Images" no Icon Image Sequence will be generated.

21 Configuration

21.1 AE Title Mapping

21.1.1 DICOM Media Storage AE Title

The DICOM Storage application provides the application entity title:

Own AET as configured in local service for the Storage SCP

22 Support of Extended Character Sets

The Siemens AXIOM Sensis DICOM application supports the ISO 8859 Latin 1 (ISO-IR 100) and ISO-IR6 character sets.

Also the Japanese language character sets JIS X 0201 (ISO-IR 13 Japanese katakana and ISO-IR 14 Japanese romaji), JIS X 0208 (ISO-IR 87 Japanese kanji) and JIS X 0212 (IOS-IR 159 Supplementary Japanese kanji) are supported in the DICOM interfaces but will not be correctly represented in the generated reports

Annex A: IOD descriptions

SIEMENS Waveform IOD description

Table A.1: WF IOD description for instances created by AXIOM Sensis® application

Attribute	Tag	Value
Group 0002 Length	(0002,0000)	
File Meta Information Version	(0002,0001)	==> binary data; value is 2 bytes long
Media Storage SOP Class UID	(0002,0002)	"1.2.840.10008.5.1.4.1.1.9.3.1"
Media Storage SOP Instance UID	(0002,0003)	"1.3.12.2.1107.5.13.2.serialno.uniqueid"
Transfer Syntax UID	(0002,0010)	"1.2.840.10008.1.2.1"
Implementation Class UID	(0002,0012)	"1.3.12.2.1107.5.9.20000101"
Implementation Version Name	(0002,0013)	"SIEMENS_SWFVC10E"
Source Application Entity Title	(0002,0016)	No value
Private Information Creator UID	(0002,0100)	No value
Private Information	(0002,0102)	No value
Specific Character Set	(0008,0005)	from Configuration
SOP Class UID	(0008,0016)	"1.2.840.10008.5.1.4.1.1.9.3.1"
SOP Instance UID	(0008,0018)	"1.3.12.2.1107.5.13.2.serialno.x.yyyyyyyyyyy"
Study Date	(0008,0020)	<yyyymmdd>
Content Date	(0008,0023)	<hhmmss>
Acquisition Datetime	(0008,002A)	<yyyymmdd hhmmss mmmm>
Study Time	(0008,0030)	<hhmmss mmmm>
Content Time	(0008,0033)	<hhmmss mmmm>
Accession Number	(0008,0050)	RIS or "Accession Number" input
Modality	(0008,0060)	"EPS"
Manufacturer	(0008,0070)	"SIEMENS"
Institution Name	(0008,0080)	From system configuration
Referring Physician's Name	(0008,0090)	RIS or "Referring Physician's name" input
Series Description	(0008,103E)	"WAVEFORM SERIES"
Patient's Name	(0010,0010)	RIS or "Patient Name" input
Patient ID	(0010,0020)	RIS or "Patient ID" input
Patient's Birth Date	(0010,0030)	<yyyymmdd>
Patient's Sex	(0010,0040)	"M", "F" or "O"
Patient's Age	(0010,1010)	calculated from "DoB" input
Synchronization Trigger	(0018,106A)	"NO TRIGGER"
Acquisition Time Synchronized	(0018,1800)	"N"
Patient Position	(0018,5100)	From "Patient Position" input
Study Instance UID	(0020,000D)	from RIS or system generated
Series Instance UID	(0020,000E)	System generated
Study ID	(0020,0010)	RIS or "Study ID" input
Series Number	(0020,0011)	System generated
Instance Number	(0020,0013)	System generated
Synchronization Frame of Reference UID	(0020,0200)	UID System generated
Private Creator	(0029,0010)	"SIEMENS CSA HEADER"
Modality Series Header Type	(0029,1018)	"WAVEFORMSERIES"
Modality Series Header Version	(0029,1019)	From system label
Modality Series Header Info	(0029,1020)	
Study Completion Date	(0032,1050)	<yyyymmdd>
Study Completion Time	(0032,1051)	<hhmmss mmmm>
Acquisition Context Sequence	(0040,0555)	
Annotation Sequence	(0040,B020)	
> Concept-name Code Sequence	(0040,A043)	System generated
>> Code Value	(0008,0100)	System codes
>> Coding Scheme Designator	(0008,0102)	System coding scheme
>> Code Meaning	(0008,0104)	System generated depending on user action
> Referenced Waveform Channels	(0040,A0B0)	System generated depending on affected channel
> Temporal Range Type	(0040,A130)	System generated depending on user action
> Referenced Datetime	(0040,A13A)	<yyyymmdd hhmmss mmmm> See note 1
> Concept Code Sequence	(0040,A168)	
>> Code Value	(0008,0100)	
>> Coding Scheme Designator	(0008,0102)	
>> Code Meaning	(0008,0104)	
Waveform Sequence	(5400,0100)	
> Waveform Originality	(003A,0004)	"ORIGINAL"
> Number of Waveform Channels	(003A,0005)	From configuration

> Number of Waveform Samples	(003A,0010)	Recording length times sampling frequency
> Sampling Frequency	(003A,001A)	"2000"
> Multiplex Group Label	(003A,0020)	From configuration: "ECG", "IECG", "Pressure", or "Indicator" or user defined from configuration.
> Channel Definition Sequence	(003A,0200)	
>> Waveform Channel Number	(003A,0202)	System number
>> Channel Label	(003A,0203)	User configuration
>> Channel Status	(003A,0205)	"OK" or "Disconnected"
>> Channel Source Sequence	(003A,0208)	Several channels at "pullback". See note 2
>>> Code Value	(0008,0100)	System codes
>>> Coding Scheme Designator	(0008,0102)	System coding scheme
>>> Code Meaning	(0008,0104)	System meaning
>> Channel Source Modifier Sequence	(003A,0209)	Electrode positions or "pullback" sites. From configuration
>>> Code Value	(0008,0100)	System codes
>>> Coding Scheme Designator	(0008,0102)	System coding scheme
>>> Code Meaning	(0008,0104)	
>> Channel Sensitivity Units Sequence	(003A,0211)	System generated
>> Channel Sensitivity Correction Factor	(003A,0212)	System generated
>> Channel Baseline	(003A,0213)	System generated
>> Channel Time Skew	(003A,0214)	0
>> Waveform Bits Stored	(003A,021A)	16
>> Filter Low Frequency	(003A,0220)	From configuration
>> Filter High Frequency	(003A,0221)	From configuration
>> Notch Filter Frequency	(003A,0222)	From configuration
>> Channel Label	(003A,0203)	System generated. Defines channel types
> Waveform Bits Allocated	(5400,1004)	16
> Waveform Sample Interpretation	(5400,1006)	"SS"
>Waveform Padding Value	(5400,100A)	==> binary data; value is 2 bytes long
> Waveform Data	(5400,1010)	==> binary data;

Note 1: The time in the recorded data to which the Annotation applies is denoted by the Referenced Datetime (0040,A13A) attribute. The Referenced Waveform Channel (0040,A0B0) refers to the (M,C) value pair of the same channel.

Note 2: The Channel Source Sequence Code Value , Code Scheme Designator and Code Meaning for Waveform IODs created by AXIOM Sensis are internal codes and no standard coding scheme is used.

SIEMENS Word.Report XA IOD description

Table A.2: XA IOD description for instances created by AXIOM Sensis® application:

Module	Attribute Name	TAG	Type	Comments
Patient	Patient's Name	0010,0010	2	RIS or "Patient Name" input
	Patient ID	0010,0020	2	RIS or "Patient ID" input
	Patient's Birth Date	0010,0030	2	RIS or "Patient Birth Date" input
	Patient's Sex	0010,0040	2	RIS or "Patient Sex" input
General Study	Study Instance UID	0020,000D	1	System generated
	Study Date	0008,0020	2	System generated
	Study Time	0008,0030	2	System generated
	Referring Physician's Name	0008,0090	2	RIS or "Referring Physician's name" input
	Study ID	0020,0010	2	RIS or "Study ID" input
	Accession Number	0008,0050	2	RIS or "Accession No" input
	Study Description	0008,1030	3	RIS or "Patient Name" input
General Series	Modality	0008,0060	1	"XA"
	Series Instance UID	0020,000E	1	System generated
	Series Number	0020,0011	2	"100"
	Series Date	0008,0021	3	Date of report creation
	Series Time	0008,0031	3	Time of report creation
	Performing Physician's Name	0008,1050	3	"Performing Physician's Name" input
General Equipment	Manufacturer	0008,0070	2	"SIEMENS "
	Institution Name	0008,0080	3	RIS or "Institution Name" input
	Manufacturer's Model Name	0008,1090	3	"AXIOM Sensis IS"
General Image	Image Number	0020,0013	2	"1"
	Patient Orientation	0020,0020	2C	Empty field
	Image Date	0008,0023	2C	Date of report creation
	Image Time	0008,0033	2C	Time of report creation
	Lossy Image Compression	0028,2110	1C	"01" for WORD reports
Image Pixel	Samples per Pixel	0028,0002	1	1
	Photometric Interpretation	0028,0004	1	"MONOCHROME2"
	Rows	0028,0010	1	See Note below
	Columns	0028,0011	1	See Note below
	Bits Allocated	0028,0100	1	8
	Bits Stored	0028,0101	1	8
	High Bit	0028,0102	1	7
	Pixel Representation	0028,0103	1	0000H (unsigned)
Cine	Pixel Data	7FE0, 0010	1	
	Frame Time	0018,1063	1C	"1000" (1sec per frame)
Multi-Frame	Recommended Display Frame Rate	0008,2144	3	"1"
	Number of Frames	0028,0008	1	Number of report pages
Frame Pointers	Frame Increment Pointer	0028,0009	1C	00181063H
	Representative Frame Number	0028,6010	3	"1"
X-Ray Image	Image Type	0008,0008	1	DERIVED\PRIMARY\SINGLE PLANE\WORD REPORT
	Pixel Intensity Relationship	0028,1040	1	"LIN "
X-Ray Acquisition	KVP	0018,0060	2	Empty field
	Radiation Setting	0018,1155	1	"GR"
	Exposure Time	0018,1150	2C	Empty field
	X-Ray Tube Current	0018,1151	2C	Empty field
XA Positioner	Positioner Motion	0018,1500	2C	"STATIC"
	Positioner Primary Angle	0018,1510	2	Empty field
	Positioner Secondary Angle	0018,1511	2	Empty field
VOLUME	Window Center	0028,1050	3	0..255

	Window Width	0028,1051	1C	1..254
SOP Common	SOP Class UID	0008,0016	1	XA IOD
	SOP Instance UID	0008,0018	1	System generated
	Specific Character Set	0008,0005	1C	"ISO_IR 100"
	Instance Creation Date	0008,0012	3	Date of report creation
	Instance Creation Time	0008,0013	3	Time of report creation

Note: The resulting image matrix size depends on the report type

Table A.3: AXIOM Sensis® report types

Report Type	Image Type Value 4	Columns	Rows	Comments
WORD document	WORD REPORT	1024	792	For WORD document pages in portrait format Printed and Subsampled from original WORD file → Lossy Compression flag 0028,2110 is set to "01"
	WORD REPORT	792	1024	For WORD document pages in landscape format Printed and Subsampled from original WORD file → Lossy Compression flag 0028,2110 is set to "01"

The following table lists the extensions for the image type attribute where the DICOM definitions are extended:

Attribute Name	Tag	Type	Notes
Image Type	(0008,0008)	1	Additional Defined Terms: Defined Terms for value 4: "WORD REPORT"

SIEMENS Private Non-Image IOD

For encoding binary data-streams not representing image data, Siemens has created a private "Non-Image IOD" according to the rules governed by the DICOM Standard. The following section will roll-out the definition of this Private IOD. It can be communicated with Network Storage Service and Offline Media Storage Services.

The Siemens "Non-Image IOD" is identified by a private Non-Image Storage SOP Class UID of

"1.3.12.2.1107.5.9.1"

Siemens Non-Image IOD – E-R Model

The E-R model in A.1.2 depicts those components of the DICOM Information Model which directly refer to the Siemens Non-Image IOD. The Frame of Reference IE, Overlay IE, Modality Lookup-Table IE, VOI Lookup-Table IE and Curve IE are not components of the Siemens Non-Image IOD.

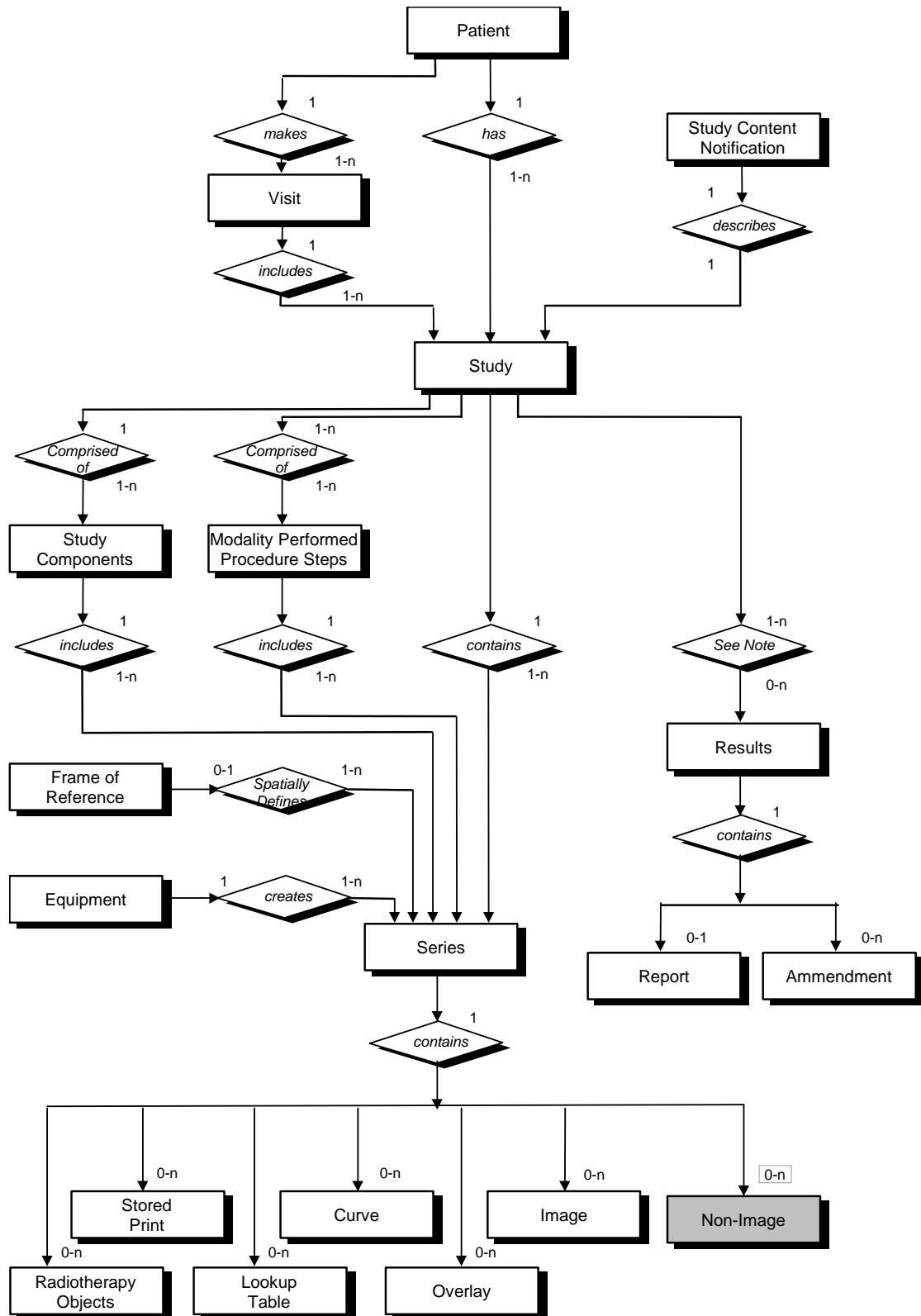

Siemens Non-Image IOD - Module Table

IE	Module	Reference	Usage
Patient	Patient	[1] PS3.3 C.7.1.1	M
Study	General Study	[1] PS3.3 C.7.2.1	M
	Patient Study	[1] PS3.3 C.7.2.2	U
Series	General Series	[1] PS3.3 C.7.3.1	M
Equipment	General Equipment	[1] PS3.3 C.7.5.1	U
CSA	CSA Image Header	A.2.1	U
	CSA Series Header	A.2.2	U
	MEDCOM Header	A.2.3	U
	MEDCOM OOG	A.2.4	U
	CSA Non-Image	A.1.3.1	M
	SOP Common	[1] PS3.3 C.12.1	M

Siemens Non-Image IOD - Modules

CSA Non-Image Module

The table in this section contains private IOD Attributes that describe CSA Non-Images.

Attribute Name	Tag	Owner	Type	Notes
Image Type	(0008,0008)	-	3	Image identification characteristics.
Acquisition Date	(0008,0022)	-	3	The date the acquisition of data that resulted in this data set started.
Acquisition Time	(0008,0023)	-	3	The time the acquisition of data that resulted in this data set started.
Derivation Description	(0008,2111)	-	3	A text description of how this data set was derived.
Acquisition Number	(0020,0012)	-	3	A number identifying the single continuous gathering of data over a period of time which resulted in this data set.
CSA Data Type	(0029,xx08)	SIEMENS CSA NON-IMAGE	1	CSA Data identification characteristics. Defined Terms: WF PRES DATA = Waveform presentation data EVENT LOG DATA = System or user event data
CSA Data Version	(0029,xx09)	SIEMENS CSA NON-IMAGE	3	Version of CSA Data Info (0029,xx10) format and CSA Non-Image Data (7FE1,xx10) format.
CSA Data Info	(0029,xx10)	SIEMENS CSA NON-IMAGE	3	Information to describe the CSA Data (7FE1,xx10).
CSA Data	(7FE1,xx10)	SIEMENS CSA NON-IMAGE	2	Binary data as byte stream.

Siemens Standard Extended Modules

CSA Image Header Module

The table in this section contains private IOD Attributes that describe the CSA Image Header:

Attribute Name	Tag	Owner	Type	Notes
CSA Image Header Type	(0029,xx08)	SIEMENS CSA HEADER	1	CSA Image Header identification

				characteristics. Defined Terms: NUM 4 = NUMARIS/4 SOM 5 = SOMARIS/5
CSA Image Header Version	(0029,xx09)	SIEMENS CSA HEADER	3	Version of CSA Image Header Info (0029,xx10) format.
CSA Image Header Info	(0029,xx10)	SIEMENS CSA HEADER	3	Manufacturer model dependent information.

CSA Series Header Module

The table in this section contains private IOD Attributes that describe the CSA Series Header:

Attribute Name	Tag	Owner	Type	Notes
CSA Series Header Type	(0029,xx28)	SIEMENS CSA HEADER	1	CSA Series Header identification characteristics. Defined Terms: NUM 4 = NUMARIS/4
CSA Series Header Version	(0029,xx29)	SIEMENS CSA HEADER	3	Version of CSA Series Header Info (0029,xx10) format.
CSA Series Header Info	(0029,xx20)	SIEMENS CSA HEADER	3	Manufacturer model dependent information.

MEDCOM Header Module

The table in this section contains private IOD Attributes that describe MEDCOM Header:

Attribute Name	Tag	Owner	Type	Notes
MedCom Header Type	(0029,xx08)	SIEMENS MEDCOM HEADER	1C	MedCom Header identification characteristics. Defined Terms: MEDCOM 1 (Required if MedCom Header Info (0029,xx10) present.)
MedCom Header Version	(0029,xx09)	SIEMENS MEDCOM HEADER	2C	Version of MedCom Header Info (0029,xx10) format. (Required if MEDCOM Header Info (0029,xx10) present.)
MedCom Header Info	(0029,xx10)	SIEMENS MEDCOM HEADER	3	Manufacturer model dependent information. The value of the attribute MedCom Header Info (0029,xx10) can be build up in each user defined format.
MedCom History Information	(0029,xx20)	SIEMENS MEDCOM HEADER	3	MedCom defined Patient Registration history information. See A.1.3.1.
PMTF Information 1	(0029,xx31)	SIEMENS MEDCOM HEADER	3	Transformation Information
PMTF Information 2	(0029,xx32)	SIEMENS MEDCOM HEADER	3	Transformation Information
PMTF Information 3	(0029,xx33)	SIEMENS MEDCOM HEADER	3	Transformation Information
PMTF Information 4	(0029,xx34)	SIEMENS MEDCOM HEADER	3	Transformation Information

MEDCOM History Information

The value of the attribute MEDCOM History Information (0029,xx20) is defined in the following way:

Part	Name	Type	Bytes	Notes
header	Identifier	string	32	Always "CSA HISTORY"
	Version	string	32	e.g. "V1.10"
>n Items	Class Name	string	64	
	Modification String	string	1024	

MEDCOM OOG Module

The table in this section contains private IOD Attributes that describe MEDCOM Object Oriented Graphics (OOG). This module is used whenever object graphics is drawn on the image and need to be stored as graphic object properties. Given the condition that the module contents was not removed by other modalities, the graphic objects remain re-animatable if such an image was transferred and is then retrieved back.

Attribute Name	Tag	Owner	Type	Notes
CSA Series Header Type	(0029,xx28)	SIEMENS MEDCOM OOG	1	MEDCOM Object Oriented Graphics (OOG) identification characteristics. Defined Terms: MEDCOM OOG 1
CSA Series Header Version	(0029,xx29)	SIEMENS MEDCOM OOG	3	Version of MEDCOM OOG Info (0029,xx10) format.
CSA Series Header Info	(0029,xx20)	SIEMENS MEDCOM OOG	3	MEDCOM Object Oriented Graphics (OOG) data.

The graphics objects are also fully drawn in the Image Overlay Plane for compatibility with other products, which do not support the MedCom OOG module. Any system not supporting the MedCom OOG module shall remove the OOG module and it's contents when modifying the image overlay plane content.

Registry of DICOM Data Elements

(0029,xx08)	SIEMENS CSA HEADER	CSA Image Header Type	CS	1
(0029,xx09)	SIEMENS CSA HEADER	CSA Image Header Version	LO	1
(0029,xx10)	SIEMENS CSA HEADER	CSA Image Header Info	OB	1
(0029,xx18)	SIEMENS CSA HEADER	CSA Series Header Type	CS	1
(0029,xx19)	SIEMENS CSA HEADER	CSA Series Header Version	LO	1
(0029,xx20)	SIEMENS CSA HEADER	CSA Series Header Info	OB	1
(0029,xx08)	SIEMENS CSA NON-IMAGE	CSA Data Type	CS	1
(0029,xx09)	SIEMENS CSA NON-IMAGE	CSA Data Version	LO	1
(0029,xx10)	SIEMENS CSA NON-IMAGE	CSA Data Info	OB	1
(0029,xx08)	SIEMENS MEDCOM HEADER	MedCom Header Type	CS	1
(0029,xx09)	SIEMENS MEDCOM HEADER	MedCom Header Version	LO	1
(0029,xx10)	SIEMENS MEDCOM HEADER	MedCom Header Info	OB	1
(0029,xx20)	SIEMENS MEDCOM HEADER	MedCom History Information	OB	1
(0029,xx31)	SIEMENS MEDCOM HEADER	PMTF Information 1	LO	1
(0029,xx32)	SIEMENS MEDCOM HEADER	PMTF Information 2	UL	1
(0029,xx33)	SIEMENS MEDCOM HEADER	PMTF Information 3	UL	1
(0029,xx34)	SIEMENS MEDCOM HEADER	PMTF Information 4	CS	1
(0029,xx08)	SIEMENS MEDCOM OOG	MedCom OOG Type	CS	1
(0029,xx09)	SIEMENS MEDCOM OOG	MedCom OOG Version	LO	1
(0029,xx10)	SIEMENS MEDCOM OOG	MedCom OOG Info	OB	1
(0029,xx00)	CARDIO-D.R. 1.0	Standard Edge Enhancement Sequence	SQ	1
(0029,xx01)	CARDIO-D.R. 1.0	Convolution Kernel Size	US	2
(0029,xx02)	CARDIO-D.R. 1.0	Convolution Kernel Coefficients	US	1-n
(0029,xx03)	CARDIO-D.R. 1.0	Edge Enhancement Gain	FL	1
(7FE1,xx10)	SIEMENS CSA NON-IMAGE	CSA Data	OB	1

Private Non-Image IOD

The AXIOM Sensis system will create numerical data that cannot be correlated to an individual image or waveform instance and therefore need to be stored in separate instance(s). This is necessary to correlate the information in the right level of the DICOM data model hierarchy. Since there is no fitting DICOM SOP Class definition, SIEMENS has created a private "Non-Image IOD" to contain numerical data heaps to be managed within a DICOM structure. Please see previous chapters of the Appendix for IOD definition and the following tables for detailed encoding of the different "Non-Image SOP Class Instances".

"overview of supplied attributes – Non-Image (WF PRES DATA, EVENT LOG DATA)"

Attribute Name	Tag	Value
Specific Character Set	(0008,0005)	from Configuration
SOP Class UID	(0008,0016)	1.3.12.2.1107.5.9.1
SOP Instance UID	(0008,0018)	
Study Date	(0008,0020)	<yyyymmdd>
Series Date	(0008,0021)	<yyyymmdd>
Study Time	(0008,0030)	<hhmmss>
Series Time	(0008,0031)	<hhmmss>
Accession Number	(0008,0050)	RIS or "Accession Number" input
Modality	(0008,0060)	EPS
Manufacturer	(0008,0070)	Siemens
Institution Name	(0008,0080)	
Performing Physician's Name	(0008,1050)	"Performing Physician 1" \ "Performing Physician 2" input
Admitting Diagnosis Description	(0018,1080)	RIS or "Admitting Diagnoses" input
Manufacturer's Model Name	(0008,1090)	AXIOM Sensis
Patient's Name	(0010,0010)	RIS or "Patient Name" input
Patient ID	(0010,0020)	RIS or "Patient ID" input
Patient's Birth Date	(0010,0030)	RIS or checked input
Patient's Sex	(0010,0040)	RIS or input (M or F or O/unknown)
Patient's Age	(0010,1010)	calculated from "DoB" input
Patient's Size	(0010,1020)	(in meters)
Patient's Weight	(0010,1030)	(in kilograms)
Patient's Address	(0010,1040)	"Address" input
Patient Comments	(0010,4000)	"Additional Info" input
Study Instance UID	(0020,000D)	from RIS or system generated
Series Instance UID	(0020,000E)	
Study ID	(0020,0010)	
Series Number	(0020,0011)	
Private Creator	(0029,00xx)	SIEMENS CSA NON-IMAGE
Data Type	(0029,xx08)	WF_PRES_DATA or EVENT_LOG_DATA
Data Version	(0029,xx09)	1.0
Requested Procedure Description	(0032,1060)	from RIS
Study Comments	(0032,4000)	"Exam Comment" input
Private Creator	(7FE1,00xx)	SIEMENS CSA NON-IMAGE
Data	(7FE1,xx10)	binary data