

# SIEMENS

**ACOM.Rec<sup>®</sup> 3.0**  
**VA03A**



**AX**

## **DICOM Conformance Statement**

V3.0 Dec 22<sup>nd</sup>, 2003

© Siemens AG 2003  
All rights reserved

Siemens AG, Medical Solutions,  
Siemensstr. 1, 91301 Forchheim, Germany

Headquarters: Berlin and Munich  
Siemens AG, Wittelsbacher Platz 2, D-80333 Munich, Germany

Table of Contents



- 1. Introduction..... 5**
  - 1.1 Overview .....5
  - 1.2 Scope and Field.....5
  - 1.3 Audience .....5
  - 1.4 Remarks .....5
  - 1.5 Definitions, Terms and Abbreviations.....6
  - 1.6 References .....6
- 2. Network Functionality..... 7**
  - 2.1 Verification.....7**
    - 2.1.1 Application Data Flow Diagram ..... 7
    - 2.1.2 Functional Definition of AE ..... 7
    - 2.1.3 Sequencing of Real World Activities..... 8
  - 2.2 Storage.....8**
    - 2.2.1 Application Data Flow Diagram ..... 8
    - 2.2.2 Functional Definition of AE ..... 8
    - 2.2.3 Sequencing of Real World Activities..... 9
  - 2.3 Query / Retrieve.....9**
    - 2.3.1 Application Data Flow Diagram ..... 9
    - 2.3.2 Functional Definition of AE ..... 10
    - 2.3.3 Sequencing of Real World Activities..... 10
- 3. AE Specifications ..... 11**
  - 3.1 Verification AE Specification .....11**
    - 3.1.1 Association Establishment Policies – Verification SCU..... 11
      - 3.1.1.1 General..... 11
      - 3.1.1.2 Number of Associations..... 11
      - 3.1.1.3 Asynchronous Nature..... 11
      - 3.1.1.4 Implementation Identifying Information ..... 11
    - 3.1.2 Association Initiation by Real-World Activity - Verification SCU 11
      - 3.1.2.1 Associated Real-World Activity - Verification SCU..... 11
      - 3.1.2.2 Proposed Presentation Contexts - Verification SCU..... 11
      - 3.1.2.3 SOP Specific Conformance Statement - Verification SCU ..... 12
    - 3.1.3 Association Acceptance Policy - Verification SCP ..... 12
  - 3.2 Storage AE Specification.....13**

3.2.1	Association Establishment Policies – Storage SCU and SCP	13
3.2.1.1	General .....	13
3.2.1.2	Number of Associations .....	13
3.2.1.3	Asynchronous Nature .....	14
3.2.1.4	Implementation Identifying Information .....	14
3.2.2	Association Initiation by Real-World Activity - Storage SCU	14
3.2.2.1	Associated Real-World Activity - Storage SCU .....	14
3.2.2.2	Proposed Presentation Contexts - Storage SCU .....	14
3.2.2.3	SOP Specific Conformance Statement - Storage SCU .....	18
3.2.3	Association Acceptance Policy - Storage SCP	18
3.2.3.1	Associated Real-World Activity - Storage SCP .....	18
3.2.3.2	Accepted Presentation Contexts - Storage SCP .....	18
3.2.3.3	SOP Specific Conformance Statement - Storage SCP .....	22
3.2.3.4	Presentation Context Acceptance Criterion - Storage SCP .....	22
3.2.3.5	Transfer Syntax Selection Policies - Storage SCP .....	22
3.3	Query / Retrieve AE Specification .....	24
3.3.1	Association Establishment Policies – Query / Retrieve SCU	24
3.3.1.1	General .....	24
3.3.1.2	Number of Associations .....	24
3.3.1.3	Asynchronous Nature .....	24
3.3.1.4	Implementation Identifying Information .....	24
3.3.2	Association Initiation by Real-World Activity – Query / Retrieve SCU .....	25
3.3.2.1	Associated Real-World Activity - Query SCU .....	25
3.3.2.2	Proposed Presentation Contexts – Query SCU .....	25
3.3.2.3	SOP Specific Conformance Statement– Query SCU .....	26
3.3.2.4	Associated Real-World Activity - Retrieve SCU .....	28
3.3.2.5	Proposed Presentation Contexts – Retrieve SCU .....	28
3.3.2.6	SOP Specific Conformance Statement– Retrieve SCU .....	29
3.4	Communication Profiles .....	31
3.4.1	Supported Communication Stacks (part 8) .....	31
3.4.2	TCP/IP Stack .....	31
3.4.3	Physical Media Support .....	31
3.5	Extensions/Specializations/Privatizations .....	31
3.5.1	Standard Extended / specialized / Private SOPs .....	31
3.5.2	Private Transfer Syntaxes .....	31
3.6	Configuration .....	32
3.6.1	AE Title/Presentation Address Mapping .....	32
3.6.2	Configurable Parameters .....	32
3.6.3	Number of Simultaneous Associations .....	32
3.6.4	Maximum PDU Size .....	32
3.6.5	Time Out .....	32
3.7	Support of Extended Character Sets .....	32
4.	Media Storage .....	33
4.1	Implementation Model .....	33
4.1.1	Application Data Flow Diagram .....	33

---

4.1.2	Functional Definition of AE .....	33
4.1.3	Sequencing of Real World Activities.....	33
4.1.4	File Meta Information Options.....	34
<b>4.2</b>	<b>AE Specification.....</b>	<b>34</b>
4.2.1	DICOM Archive Specification .....	34
4.2.1.1	File Meta Information for the Application Entity.....	34
4.2.1.2	Real-World Activities for this Application Entity.....	34
4.2.2	Application profiles.....	35
<b>HICOR/ACOM Report Keys .....</b>		<b>39</b>
4.2.3	Augmented and Private Profiles .....	40
4.2.3.1	AUG-XABC-DYNAMIC-CD.....	41
4.2.3.3	Private Application Profiles PRI-AREC-CD.....	44
4.2.4	Anonymizing of patient data .....	46
<b>4.3</b>	<b>Extensions, Specializations and Privatizations of SOP Classes and Transfer Syntaxes .....</b>	<b>48</b>
4.3.1	Standard Extensions of XA Storage SOP classes .....	48
4.3.2	Private Storage SOP classes .....	48
4.3.2.1	Extension, Specialization for SIEMENS Non-Image Objects.....	48
4.3.3	Private Transfer Syntaxes .....	48
<b>4.4</b>	<b>Configuration.....</b>	<b>49</b>
4.4.1	AE Title Mapping.....	49
<b>4.5</b>	<b>Support of Extended Character Sets .....</b>	<b>49</b>

## 1. Introduction

### 1.1 Overview

The Conformance Statement describes the DICOM interface for the Siemens ACOM.Rec® VA03A application in terms of part 2 of [DICOM].

This introduction describes the application's implemented DICOM functionality in general terms.

### 1.2 Scope and Field

The Siemens product ACOM.Rec® is an application to write images from the Siemens ACOM.PC® product onto DICOM CDs.

The ACOM.Rec® supports the storage of images utilizing the DICOM XA, SC, US, USMF, NM and WF IODs.

### 1.3 Audience

This document is intended for hospital staff, health system integrators, software designers or implementers. It is assumed that the reader has a working understanding of DICOM.

### 1.4 Remarks

DICOM, by itself, does not guarantee interoperability. The Conformance Statement however facilitates a first-level validation for interoperability between different applications supporting the same DICOM functionality as SCU and SCP, respectively.

This Conformance Statement is not intended to replace validation with other DICOM equipment to ensure proper exchange of information intended.

The scope of this Conformance Statement is to facilitate communication with Siemens and other vendors' Medical equipment. The Conformance Statement should be read and understood in conjunction with the DICOM 3.0 Standard [DICOM]. However, by itself it is not guaranteed to ensure the desired interoperability and a successful interconnectivity.

The User should be aware of the following important issues:

The comparison of different conformance statements is the first step towards assessing interconnectivity between Siemens and non-Siemens equipment.

Test procedures should be defined and tests should be performed by the user to validate the connectivity desired. DICOM itself and the conformance parts do not specify this.

The standard will evolve to meet the users' future requirements. Siemens is actively involved in developing the standard further and therefore reserves the right to make changes to its products or to discontinue its delivery.

Siemens reserves the right to modify the design and specification contained herein without prior notice. Please contact your local Siemens representative for the most recent product information.

## 1.5 Definitions, Terms and Abbreviations

Definitions, terms and abbreviations used in this document are defined within the different parts of the DICOM standard.

Additional Abbreviations are as follows

AE	DICOM Application Entity
FSE	Field Service Engineer
FSC	File Set Creator
FSR	File Set Reader
FSU	File Set Updater
O	Optional Key Attribute
R	Required Key Attribute
IOD	DICOM Information Object Definition
PDU	DICOM Protocol Data Unit
SCU	DICOM Service Class User (DICOM client)
SCP	DICOM Service Class Provider (DICOM server)
SOP	DICOM Service-Object Pair
U	Unique Key Attribute
UI	User Interface
UID	Unique Identifier
VR	Value Representation

## 1.6 References

[DICOM] Digital Imaging and Communications in Medicine (DICOM), NEMA PS 3.1-3.13, 2001

## 2. Network Functionality

The ACOM.Rec® DICOM network service implementation acts as SCU or SCP for the specified services:

- DICOM Verification (C-ECHO) as SCU and SCP
- DICOM Storage (C-STORE) as SCU and SCP
- DICOM Query (C-FIND) as SCU
- DICOM Retrieve (C-MOVE) as SCU

### 2.1 Verification

The Verification service class defines an application-level class of service which allows for the operator to verify the ability of an application on a remote node to respond to DICOM messages. The DICOM Service Tool application supports the Verification service to act as SCU.

The other direction - responding to Verification requests from remote applications - is handled by the Storage SCP application.

#### 2.1.1 Application Data Flow Diagram

The Siemens DICOM network implementation is a Windows NT application and acts as SCU for the Verification service.

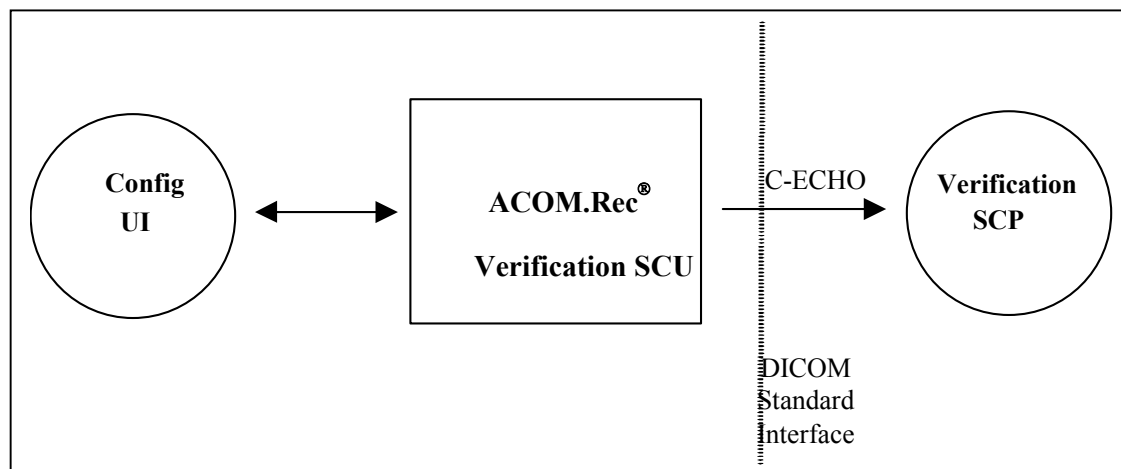

#### 2.1.2 Functional Definition of AE

The ACOM.Rec® product supports the DICOM Verification service as SCU. It opens an association to the remote application and sends a Verification message to verify that the remote application can respond to DICOM messages.

The Verification SCP is included in the Storage SCP.

### 2.1.3 Sequencing of Real World Activities

The ACOM.Rec® application provides configuration pages to configure the devices and also the remote DICOM nodes. There a button is provided to check for a configured remote DICOM node. When the button is pressed then ACOM.Rec will issue a Verification and then a Query Request.

## 2.2 Storage

The ACOM.Rec® application supports the DICOM services

- Send (C-STORE) as an SCU
- Receive (C-STORE) as an SCP
- Verification (C-ECHO) as an SCP

### 2.2.1 Application Data Flow Diagram

The Siemens DICOM network implementation is a Windows NT application and acts as SCU and SCP for the Storage service and as SCP for the Verification service

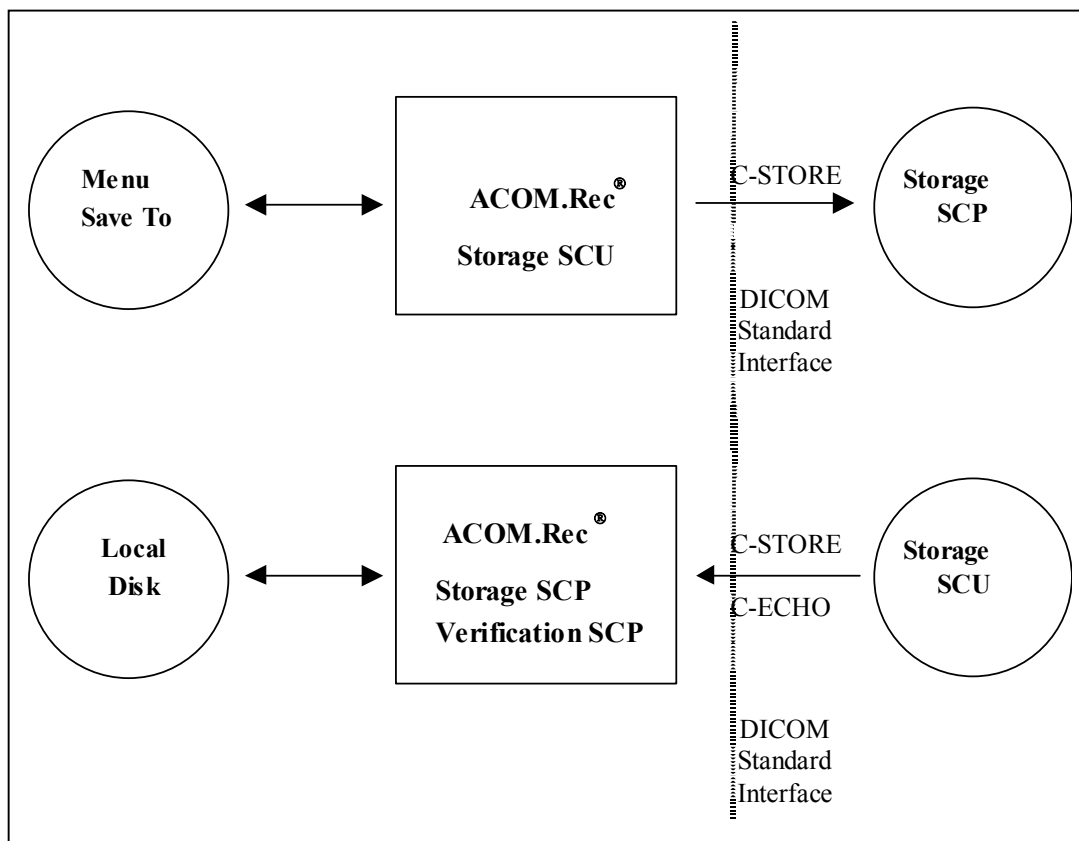

### 2.2.2 Functional Definition of AE

The ACOM.Rec® product supports the DICOM Storage service as SCU. For each selected patient it opens an association to the remote application and sends the images.

The Storage SCP is operating as a background daemon process. It is existing while the ACOM.Rec application is existing or while there are running jobs.

The Verification SCP is included in the Storage SCP.

### 2.2.3 Sequencing of Real World Activities

The ACOM.Rec® VA03A application provides a User Interface to select patients or studies and send to remote DICOM nodes.

## 2.3 Query / Retrieve

The ACOM.Rec® application supports the DICOM services

- Query (C-FIND) as an SCU
- Retrieve (C-MOVE) as an SCU

### 2.3.1 Application Data Flow Diagram

The Siemens DICOM network implementation is a Windows NT application and acts as Query / Retrieve SCU to request database information and images from remote nodes

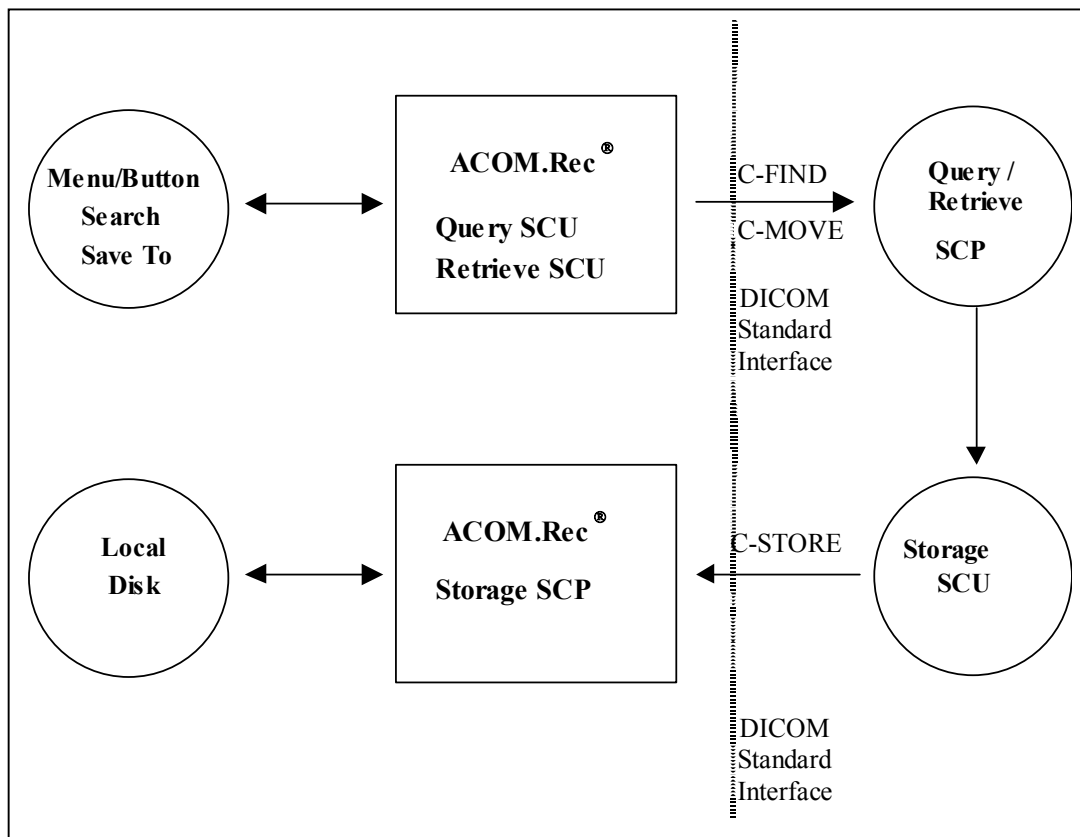

### **2.3.2 Functional Definition of AE**

The ACOM.Rec® product supports the DICOM Query and Retrieve service as SCU. It opens an association to the remote application and queries for database information or retrieves the images of a selected study or series.

### **2.3.3 Sequencing of Real World Activities**

The ACOM.Rec® VA03A application provides a User Interface to query a remote node for its patient information (with or without explicit query criteria) or select studies or series and request a Retrieve from the remote DICOM node.

## 3. AE Specifications

### 3.1 Verification AE Specification

#### 3.1.1 Association Establishment Policies – Verification SCU

##### 3.1.1.1 General

The configuration of the ACOM.Rec application defines the Application Entity Title.

##### 3.1.1.2 Number of Associations

The Siemens DICOM application initiates one association at a time, one for each Verification request being initiated by the user.

##### 3.1.1.3 Asynchronous Nature

The ACOM.Rec software does not support asynchronous communication (multiple outstanding transactions over a single association).

##### 3.1.1.4 Implementation Identifying Information

Implementation Class UID	"1.3.12.2.1107.5.4.9.40"
Implementation Version Name	"ACOM_PC_40"

#### 3.1.2 Association Initiation by Real-World Activity - Verification SCU

The ACOM.Rec application attempts to initiate a new association for

- DIMSE C-ECHO

Service operations.

##### 3.1.2.1 Associated Real-World Activity - Verification SCU

The associated Real-World activity is a C-ECHO request initiated by the DICOM Configuration User Interface of the ACOM.Rec application. If the process successfully establishes an association to a remote Application Entity, it will send the C-ECHO-Request via the open association to verify that the remote Application Entity is responding to DICOM messages.

##### 3.1.2.2 Proposed Presentation Contexts - Verification SCU

The Siemens DICOM application will propose Presentation Contexts as shown in the following table

Presentation Context Table					
Abstract Syntax		Transfer Syntax		Role	Extended Negotiation
Name	UID	Name List	UID List		
Verification Service Class	1.2.840.10008.1.1	DICOM Implicit VR Little Endian	1.2.840.10008.1.2	SCU	None

**3.1.2.3 SOP Specific Conformance Statement - Verification SCU**

The Application conforms to the definition of a Verification SCU in accordance to the DICOM Standard.

**3.1.3 Association Acceptance Policy - Verification SCP**

The Verification SCP is part of the Storage SCP – see next section.

## 3.2 Storage AE Specification

The ACOM.Rec® application provides one AE being used when initiating associations to remote DICOM nodes.

SIEMENS ACOM.Rec DICOM product provides Standard Conformance to the following DICOM SOP Classes as an SCU and SCP:

SOP Class Name	SOP Class UID
XA (X-Ray Angiographic) Image Storage	1.2.840.10008.5.1.4.1.1.12.1
SC (Secondary Capture) Image Storage	1.2.840.10008.5.1.4.1.1.7
US (Ultrasound) Image Storage	1.2.840.10008.5.1.4.1.1.6.1
US Multi-Frame Image Storage	1.2.840.10008.5.1.4.1.1.3.1
Ultrasound Image Storage (retired)	1.2.840.10008.5.1.4.1.1.6
Ultrasound Multi-frame Image Storage (retired)	1.2.840.10008.5.1.4.1.1.3
NM (Nuclear Medicine) Image Storage	1.2.840.10008.5.1.4.1.1.20
12-lead ECG Waveform Storage	1.2.840.10008.5.1.4.1.1.9.1.1
General ECG Waveform Storage	1.2.840.10008.5.1.4.1.1.9.1.2
Ambulatory ECG Waveform Storage	1.2.840.10008.5.1.4.1.1.9.1.3
Hemodynamic Waveform Storage	1.2.840.10008.5.1.4.1.1.9.2.1
Cardiac Electrophysiology Waveform Storage	1.2.840.10008.5.1.4.1.1.9.3.1
Basic Voice Audio Waveform Storage	1.2.840.10008.5.1.4.1.1.9.4.1
Syngo Non Image Storage	1.3.12.2.1107.5.9.1
Verification (only SCP)	1.2.840.10008.1.1

### 3.2.1 Association Establishment Policies – Storage SCU and SCP

#### 3.2.1.1 General

The configuration of the ACOM.Rec application defines the Application Entity Title and its port number.

#### 3.2.1.2 Number of Associations

The Siemens DICOM application initiates several associations at a time, one for the selected images of each patient to be transferred.

It accepts and handles multiple associations in parallel.

### 3.2.1.3 Asynchronous Nature

The ACOM.Rec software does not support asynchronous communication (multiple outstanding transactions over a single association).

### 3.2.1.4 Implementation Identifying Information

Implementation Class UID	"1.3.12.2.1107.5.4.9.40"
Implementation Version Name	" ACOM_PC_40"

## 3.2.2 Association Initiation by Real-World Activity - Storage SCU

The ACOM.Rec application attempts to initiate a new association for

- DIMSE C-STORE

Service operations.

### 3.2.2.1 Associated Real-World Activity - Storage SCU

The associated Real-World activity is a C-Store request initiated by User Interface of the ACOM.Rec application. If the process successfully establishes an association to the remote Application Entity, it will send the selected images of that patient one after the other via the open association.

If the C-STORE Response from the remote Application contains an error status the association is aborted.

### 3.2.2.2 Proposed Presentation Contexts - Storage SCU

The Siemens DICOM application will propose Presentation Contexts as shown in the following table

Presentation Context Table					
Abstract Syntax		Transfer Syntax		Role	Extended Negotiation
Name	UID	Name List	UID List		
XA Image Storage Service Class	1.2.840.10008.5.1.4.1.1.12.1	DICOM Explicit VR Little Endian	1.2.840.10008.1.2.1	SCU	None
		DICOM Explicit VR Big Endian	1.2.840.10008.1.2.2		
		DICOM Implicit VR Little Endian	1.2.840.10008.1.2		
		JPEG lossy Baseline (8bit)	1.2.840.10008.1.2.4.50		

		JPEG lossy Extended (12bit)	1.2.840.10008.1.2.4.51		
		JPEG lossless Process 14	1.2.840.10008.1.2.4.70		
SC Image Storage Service Class	1.2.840.10008.5.1.4.1.1.7	DICOM Explicit VR Little Endian	1.2.840.10008.1.2.1	SCU	None
		DICOM Explicit VR Big Endian	1.2.840.10008.1.2.2		
		DICOM Implicit VR Little Endian	1.2.840.10008.1.2		
		JPEG lossy Baseline (8bit)	1.2.840.10008.1.2.4.50		
		JPEG lossy Extended (12bit)	1.2.840.10008.1.2.4.51		
		JPEG lossless Process 14	1.2.840.10008.1.2.4.70		
US Image Storage Service Class	1.2.840.10008.5.1.4.1.1.6.1	DICOM Explicit VR Little Endian	1.2.840.10008.1.2.1	SCU	None
		DICOM Explicit VR Big Endian	1.2.840.10008.1.2.2		
		DICOM Implicit VR Little Endian	1.2.840.10008.1.2		
		RLE lossless	1.2.840.10008.1.2.5		
		JPEG lossy Baseline (8bit)	1.2.840.10008.1.2.4.50		
US Multiframe Image Storage Service Class	1.2.840.10008.5.1.4.1.1.3.1	DICOM Explicit VR Little Endian	1.2.840.10008.1.2.1	SCU	None
		DICOM Explicit VR Big Endian	1.2.840.10008.1.2.2		
		DICOM Implicit VR Little Endian	1.2.840.10008.1.2		
		RLE lossless	1.2.840.10008.1.2.5		
		JPEG lossy Baseline (8bit)	1.2.840.10008.1.2.4.50		
		JPEG lossy Extended (12bit)	1.2.840.10008.1.2.4.51		

Ultrasound Image Storage (retired)	1.2.840.10008.5.1.4.1.1.6	DICOM Explicit VR Little Endian	1.2.840.10008.1.2.1	SCU	None
		DICOM Explicit VR Big Endian	1.2.840.10008.1.2.2		
		DICOM Implicit VR Little Endian	1.2.840.10008.1.2		
		JPEG lossy Baseline (8bit)	1.2.840.10008.1.2.4.50		
		JPEG lossy Extended (12bit)	1.2.840.10008.1.2.4.51		
		JPEG lossless Process 14	1.2.840.10008.1.2.4.70		
Ultrasound Multi-frame Image Storage (retired)	1.2.840.10008.5.1.4.1.1.3	DICOM Explicit VR Little Endian	1.2.840.10008.1.2.1	SCU	None
		DICOM Explicit VR Big Endian	1.2.840.10008.1.2.2		
		DICOM Implicit VR Little Endian	1.2.840.10008.1.2		
		JPEG lossy Baseline (8bit)	1.2.840.10008.1.2.4.50		
		JPEG lossy Extended (12bit)	1.2.840.10008.1.2.4.51		
		JPEG lossless Process 14	1.2.840.10008.1.2.4.70		
NM Image Storage Service Class	1.2.840.10008.5.1.4.1.1.20	DICOM Explicit VR Little Endian	1.2.840.10008.1.2.1	SCU	None
		DICOM Explicit VR Big Endian	1.2.840.10008.1.2.2		
		DICOM Implicit VR Little Endian	1.2.840.10008.1.2		
12-lead ECG Waveform Storage	1.2.840.10008.5.1.4.1.1.9.1.1	DICOM Explicit VR Little Endian	1.2.840.10008.1.2.1	SCU	None
		DICOM Explicit VR Big Endian	1.2.840.10008.1.2.2		
		DICOM Implicit VR Little Endian	1.2.840.10008.1.2		

General ECG Waveform Storage	1.2.840.10008.5.1.4.1.1.9.1. 2	DICOM Explicit VR Little Endian	1.2.840.10008.1.2.1	SCU	None
		DICOM Explicit VR Big Endian	1.2.840.10008.1.2.2		
		DICOM Implicit VR Little Endian	1.2.840.10008.1.2		
Ambulatory ECG Waveform Storage	1.2.840.10008.5.1.4.1.1.9.1. 3	DICOM Explicit VR Little Endian	1.2.840.10008.1.2.1	SCU	None
		DICOM Explicit VR Big Endian	1.2.840.10008.1.2.2		
		DICOM Implicit VR Little Endian	1.2.840.10008.1.2		
Hemodynamic Waveform Storage	1.2.840.10008.5.1.4.1.1.9.2. 1	DICOM Explicit VR Little Endian	1.2.840.10008.1.2.1	SCU	None
		DICOM Explicit VR Big Endian	1.2.840.10008.1.2.2		
		DICOM Implicit VR Little Endian	1.2.840.10008.1.2		
Cardiac Electrophysiology Waveform Storage	1.2.840.10008.5.1.4.1.1.9.3. 1	DICOM Explicit VR Little Endian	1.2.840.10008.1.2.1	SCU	None
		DICOM Explicit VR Big Endian	1.2.840.10008.1.2.2		
		DICOM Implicit VR Little Endian	1.2.840.10008.1.2		
Basic Voice Audio Waveform Storage	1.2.840.10008.5.1.4.1.1.9.4. 1	DICOM Explicit VR Little Endian	1.2.840.10008.1.2.1	SCU	None
		DICOM Explicit VR Big Endian	1.2.840.10008.1.2.2		
		DICOM Implicit VR Little Endian	1.2.840.10008.1.2		
Syngo Non Image private Storage Service Class	1.3.12.2.1107.5.9.1	DICOM Explicit VR Little Endian	1.2.840.10008.1.2.1	SCU	None
		DICOM Explicit VR Big Endian	1.2.840.10008.1.2.2		
		DICOM Implicit VR Little Endian	1.2.840.10008.1.2		

All uncompressed Transfer syntaxes are presented in one Presentation Context, with the Explicit VR Little Endian as the preferred Transfer Syntax.

ACOM.Rec will not change Transfer Syntaxes when trying to send out RLE or JPEG lossy images. If a DICOM SCP cannot handle RLE or JPEG lossy compression then ACOM.Rec will not send those

images.

### 3.2.2.3 SOP Specific Conformance Statement - Storage SCU

The ACOM.Rec application will merge Detached Patient Management information into the image objects when sending them to the network. This will create new Study, Series and SOP Instance UIDs.

The DICOM images sent by the ACOM.Rec application may contain additional private elements that have to be discarded by a DICOM system when modifying the image.

The DICOM nodes are responsible for data consistency when modifying images. All unknown private attributes have to be removed upon modification!

### 3.2.3 Association Acceptance Policy - Storage SCP

The ACOM.Rec application attempts to accept a new association for

- DIMSE C-ECHO
- DIMSE C-STORE

Service operations.

#### 3.2.3.1 Associated Real-World Activity - Storage SCP

The associated Real-World activity is an Image transfer initiated by a remote node. After successfully establishing an association, the ACOM.Rec background process will receive the images via the open association and store them to the local hard disk.

#### 3.2.3.2 Accepted Presentation Contexts - Storage SCP

The Siemens DICOM application will accept Presentation Contexts as shown in the following table

Presentation Context Table					
Abstract Syntax		Transfer Syntax		Role	Extended Negotiation
Name	UID	Name List	UID List		

<p>XA Image Storage Service Class</p>	<p>1.2.840.10008.5.1.4.1.1.12.1</p>	<p>DICOM Explicit VR Little Endian                      DICOM Explicit VR Big Endian                      DICOM Implicit VR Little Endian                      JPEG lossy Baseline (8bit)                      JPEG lossy Extended (12bit)                      JPEG lossless Process 14</p>	<p>1.2.840.10008.1.2.1                      1.2.840.10008.1.2.2                      1.2.840.10008.1.2                      1.2.840.10008.1.2.4.50                      1.2.840.10008.1.2.4.51                      1.2.840.10008.1.2.4.70</p>	<p>SCP</p>	<p>None</p>
<p>SC Image Storage Service Class</p>	<p>1.2.840.10008.5.1.4.1.1.7</p>	<p>DICOM Explicit VR Little Endian                      DICOM Explicit VR Big Endian                      DICOM Implicit VR Little Endian                      JPEG lossless Process 14                      JPEG lossy Baseline (8bit)                      JPEG lossy Extended (12bit)</p>	<p>1.2.840.10008.1.2.1                      1.2.840.10008.1.2.2                      1.2.840.10008.1.2                      1.2.840.10008.1.2.4.70                      1.2.840.10008.1.2.4.50                      1.2.840.10008.1.2.4.51</p>	<p>SCP</p>	<p>None</p>
<p>US Image Storage Service Class</p>	<p>1.2.840.10008.5.1.4.1.1.6.1</p>	<p>DICOM Explicit VR Little Endian                      DICOM Explicit VR Big Endian                      DICOM Implicit VR Little Endian                      RLE lossless                      JPEG lossy Baseline (8bit)</p>	<p>1.2.840.10008.1.2.1                      1.2.840.10008.1.2.2                      1.2.840.10008.1.2                      1.2.840.10008.1.2.5                      1.2.840.10008.1.2.4.50</p>	<p>SCP</p>	<p>None</p>
<p>US Multiframe Image Storage Service Class</p>	<p>1.2.840.10008.5.1.4.1.1.3.1</p>	<p>DICOM Explicit VR Little Endian                      DICOM Explicit VR Big Endian                      DICOM Implicit VR Little Endian</p>	<p>1.2.840.10008.1.2.1                      1.2.840.10008.1.2.2                      1.2.840.10008.1.2</p>	<p>SCP</p>	<p>None</p>

		RLE lossless	1.2.840.10008.1.2.5		
		JPEG lossy Baseline (8bit)	1.2.840.10008.1.2.4.50		
		JPEG lossy Extended (12bit)	1.2.840.10008.1.2.4.51		
Ultrasound Image Storage (retired)	1.2.840.10008.5.1.4.1.1.6	DICOM Explicit VR Little Endian	1.2.840.10008.1.2.1	SCP	None
		DICOM Explicit VR Big Endian	1.2.840.10008.1.2.2		
		DICOM Implicit VR Little Endian	1.2.840.10008.1.2		
		JPEG lossy Baseline (8bit)	1.2.840.10008.1.2.4.50		
		JPEG lossy Extended (12bit)	1.2.840.10008.1.2.4.51		
		JPEG lossless Process 14	1.2.840.10008.1.2.4.70		
Ultrasound Multi-frame Image Storage (retired)	1.2.840.10008.5.1.4.1.1.3	DICOM Explicit VR Little Endian	1.2.840.10008.1.2.1	SCP	None
		DICOM Explicit VR Big Endian	1.2.840.10008.1.2.2		
		DICOM Implicit VR Little Endian	1.2.840.10008.1.2		
		JPEG lossy Baseline (8bit)	1.2.840.10008.1.2.4.50		
		JPEG lossy Extended (12bit)	1.2.840.10008.1.2.4.51		
		JPEG lossless Process 14	1.2.840.10008.1.2.4.70		
NM Image Storage Service Class	1.2.840.10008.5.1.4.1.1.20	DICOM Explicit VR Little Endian	1.2.840.10008.1.2.1	SCP	None
		DICOM Explicit VR Big Endian	1.2.840.10008.1.2.2		
		DICOM Implicit VR Little Endian	1.2.840.10008.1.2		

12-lead ECG Waveform Storage	1.2.840.10008.5.1.4.1.1.9.1. 1	DICOM Explicit VR Little Endian	1.2.840.10008.1.2.1	SCP	None
		DICOM Explicit VR Big Endian	1.2.840.10008.1.2.2		
		DICOM Implicit VR Little Endian	1.2.840.10008.1.2		
General ECG Waveform Storage	1.2.840.10008.5.1.4.1. 1.9.1.2	DICOM Explicit VR Little Endian	1.2.840.10008.1.2.1	SCP	None
		DICOM Explicit VR Big Endian	1.2.840.10008.1.2.2		
		DICOM Implicit VR Little Endian	1.2.840.10008.1.2		
Ambulatory ECG Waveform Storage	1.2.840.10008.5.1.4.1.1.9.1. 3	DICOM Explicit VR Little Endian	1.2.840.10008.1.2.1	SCP	None
		DICOM Explicit VR Big Endian	1.2.840.10008.1.2.2		
		DICOM Implicit VR Little Endian	1.2.840.10008.1.2		
Hemodynamic Waveform Storage	1.2.840.10008.5.1.4.1.1.9.2. 1	DICOM Explicit VR Little Endian	1.2.840.10008.1.2.1	SCP	None
		DICOM Explicit VR Big Endian	1.2.840.10008.1.2.2		
		DICOM Implicit VR Little Endian	1.2.840.10008.1.2		
Cardiac Electrophysiology Waveform Storage	1.2.840.10008.5.1.4.1.1.9.3. 1	DICOM Explicit VR Little Endian	1.2.840.10008.1.2.1	SCP	None
		DICOM Explicit VR Big Endian	1.2.840.10008.1.2.2		
		DICOM Implicit VR Little Endian	1.2.840.10008.1.2		
Basic Voice Audio Waveform Storage	1.2.840.10008.5.1.4.1.1.9.4. 1	DICOM Explicit VR Little Endian	1.2.840.10008.1.2.1	SCP	None
		DICOM Explicit VR Big Endian	1.2.840.10008.1.2.2		
		DICOM Implicit VR Little Endian	1.2.840.10008.1.2		
Syngo Non Image private Storage Service Class	1.3.12.2.1107.5.9.1	DICOM Explicit VR Little Endian	1.2.840.10008.1.2.1	SCP	None
		DICOM Explicit VR Big Endian	1.2.840.10008.1.2.2		
		DICOM Implicit VR Little Endian	1.2.840.10008.1.2		

Verification	1.2.840.10008.1.1	DICOM Explicit VR Little Endian	1.2.840.10008.1.2.1	SCP	None
		DICOM Explicit VR Big Endian	1.2.840.10008.1.2.2		
		DICOM Implicit VR Little Endian	1.2.840.10008.1.2		

### 3.2.3.3 SOP Specific Conformance Statement - Storage SCP

The ACOM.Rec application conforms to the Full Storage Service Class at Level 2.

The DICOM images received by the ACOM.Rec application may contain additional private elements. They are not discarded when stored to local hard disk (if the images were received with Explicit Value Representation). ACOM.Rec will not convert private attributes either.

ACOM.Rec will fill in missing offset tables for the JPEG transfer syntaxes when receiving the images. It will also create DICOMDIR objects for the images and generate the IconImageSQ items (Icon image size 128<sup>2</sup> or smaller depending on original image size).

In the event of a successful C-STORE operation, the image has been successfully written onto disk.

The DICOM receiver returns the status Success upon successful operation otherwise one of the following status codes is returned:

- Refused (A700):  
This error status indicates a lack of Resources (e.g. not enough disk space)
- Error (A900 or C000):  
An error occurred while processing the image that makes it impossible to proceed. The image will not be stored.

### 3.2.3.4 Presentation Context Acceptance Criterion - Storage SCP

The ACOM.Rec DICOM application will accept any number of verification or storage SOP classes that are listed above. There is no limit on the number of presentation contexts accepted except for the DICOM limit. In the event that the Siemens DICOM application runs out of resources, it will reject the association request.

### 3.2.3.5 Transfer Syntax Selection Policies - Storage SCP

The Siemens DICOM application supports

- the Implicit VR Little Endian, the Explicit VR Little Endian and Explicit VR Big Endian transfer syntaxes  
Explicit VR Little Endian should be preferred by SCU for uncompressed image transfer.
- the RLE lossless transfer syntax
- the JPEG Lossless Non-hierarchical transfer syntax.
- the JPEG lossy baseline and extended transfer syntaxes

Any proposed presentation context that includes one of these transfer syntaxes will be accepted. Any proposed presentation context that does not include one of these transfer syntaxes will be rejected.

### 3.3 Query / Retrieve AE Specification

The ACOM.Rec® application provides one AE being used when initiating associations to remote DICOM nodes.

SIEMENS ACOM.Rec DICOM product provides Standard Conformance to the following DICOM SOP Classes as an SCU:

SOP Class Name	SOP Class UID
Study Root Query/Retrieve Information Model - FIND	1.2.840.10008.5.1.4.1.2.2.1
Study Root Query/Retrieve Information Model - MOVE	1.2.840.10008.5.1.4.1.2.2.2

#### 3.3.1 Association Establishment Policies – Query / Retrieve SCU

##### 3.3.1.1 General

The configuration of the ACOM.Rec application defines the Application Entity Title and its port number.

##### 3.3.1.2 Number of Associations

The Siemens DICOM application initiates several associations at a time.

For Query it initiates a new association to the remote node and issues the C-FIND request to retrieve all the requested patient and study information matching the search criteria. ACOM.Rec initiates in parallel a second association to the destination node to query for all the series information for each study information returned on the first association.

For the Retrieve request (C-MOVE) only one association is initiated per destination.

But ACOM.Rec accepts and handles multiple associations in parallel, for example to receive the requested images in parallel from different destinations.

##### 3.3.1.3 Asynchronous Nature

The ACOM.Rec software does not support asynchronous communication (multiple outstanding transactions over a single association).

##### 3.3.1.4 Implementation Identifying Information

Implementation Class UID	"1.3.12.2.1107.5.4.9.40"
Implementation Version Name	"ACOM_PC_40"

### 3.3.2 Association Initiation by Real-World Activity – Query / Retrieve SCU

The ACOM.Rec application attempts to initiate a new association for

- DIMSE C-FIND
- DIMSE C-MOVE

Service operations.

**The DIMSE C-FIND-CANCEL is issued on the C-FIND association.**

#### 3.3.2.1 Associated Real-World Activity - Query SCU

The associated Real-World activity is a C-FIND request initiated by User Interface of the ACOM.Rec application. If the process successfully establishes an association to the remote Application Entity, it will send the query request for the patient and study information over the open association.

In parallel ACOM.Rec tries to initiate a second association to the remote Application Entity. This second association is used to automatically query for the series information of each Study returned by the remote AE on the first association.

All Patient/Study/Series information is then combined and displayed in the Browsing User Interface of ACOM.Rec. There the user can select a patient or specific study/exam and ask to retrieve them from the remote AE.

If the C-FIND Response from the remote Application contains an error status the association is aborted.

If the remote node returns more results than the maximum number of matches (default is 3000), then ACOM.Rec will issue a C-FIND-CANCEL Request. If the remote AE still continues sending results then ACOM.Rec will abort the association.

#### 3.3.2.2 Proposed Presentation Contexts – Query SCU

The Siemens DICOM application will propose Presentation Contexts as shown in the following table

Presentation Context Table					
Abstract Syntax		Transfer Syntax		Role	Extended Negotiation
Name	UID	Name List	UID List		
Study Root Query/Retrieve Find	1.2.840.10008.5.1.4.1.2.2.1	DICOM Explicit VR Little Endian	1.2.840.10008.1.2.1	SCU	None
		DICOM Explicit VR Big Endian	1.2.840.10008.1.2.2		
		DICOM Implicit VR Little Endian	1.2.840.10008.1.2		

Note: C-FIND Extended Negotiation will be NOT supported by the SCU.

### 3.3.2.3 SOP Specific Conformance Statement– Query SCU

The Siemens DICOM Query/Retrieve SCU supports hierarchical queries with all mandatory search keys. The following tables describe the search keys for the supported query model that the Siemens Query application supports as an SCU:

#### STUDY LEVEL KEYS FOR THE STUDY ROOT QUERY/RETRIEVE INFORMATION MODEL: Query Level (0008,0052) = STUDY

Attribute Description	Tag	Type	Matching	User input	Return value displayed
Patient's Name	(0010,0010)	R	Wildcard or Universal (Null)	Enter value	yes
Patient ID	(0010,0020)	R	Wildcard or Universal (Null)	Enter value	yes
Patient's Birth Date	(0010,0030)	O	Single value or Universal (Null)	Enter value	yes
Patient's Sex	(0010,0040)	O	Wildcard or Universal (Null)	Enter value	yes
Patient Comments	(0010,4000)	O	Universal (Null)	-	yes
Study ID	(0020,0010)	R	Wildcard or Universal (Null)	Enter value	yes
Accession Number	(0008,0050)	R	Wildcard or Universal (Null)	Enter value	yes
Study Date	(0008,0020)	R	Range or Universal (Null)	Range of dates	yes
Study Time	(0008,0030)	R	Universal (Null)	-	yes
Study Instance UID	(0020,000D)	U	Universal (Null)	-	-
Referring Physician's Name	(0008,0090)	O	Universal (Null)	-	yes
Study Description	(0008,1030)	O	Wildcard or Universal (Null)	Enter value	Yes

#### SERIES LEVEL KEYS FOR THE STUDY ROOT QUERY/RETRIEVE INFORMATION MODEL: Query Level (0008,0052) = SERIES

Attribute Description	Tag	Type	Matching	User input	Return value displayed
Modality	(0008,0060)	R	Single Value or Universal (Null)	Select value	Yes
Series Number	(0020,0011)	R	Universal (Null)	-	-
Series Instance UID	(0020,000E)	U	Universal (Null)	-	-
Performing Physician's Name	(0008,1050)	O	Wildcard or Universal (Null)	Enter value	Yes

Series Date	(0008,0021)	O	Range or Universal (Null)	Range of dates	Yes
Series Time	(0008,0031)	O	Universal (Null)	-	Yes
Series Description	(0008,103E)	O	Universal (Null)	-	-
Institution Name	(0008,0080)	O	Wildcard or Universal (Null)	Enter value	Yes
PerformedProcedureStep ID	(0040,0253)	O	Universal (Null)	-	-
PerformedProcedureStep Start Date	(0040, 0244)	O	Universal (Null)	-	-
PerformedProcedureStep Start Time	(0040, 0245)	O	Universal (Null)	-	-
PerformedProcedureStep Description	(0040,0254)	O	Universal (Null)	-	-
From Study level					
Study Instance UID	(0020,000D)	U	Single value	-	-

The following Element will be part in every query request message and always have the fixed value of "ISO\_IR 100".

Specific Character Set	(0008,0005)	O	-	-	-
------------------------	-------------	---	---	---	---

The Search string for the Performing Physicians Name is extended with a wildcard in front and after the entered string to support also the search on second and third physician.

Note: The Search on a DICOM device is Case Sensitive!

Support for:

- DIMSE C-FIND-CANCEL

The ACOM.Rec Application does issue a C-FIND-Cancel request if it receives more than the maximum number of matches (default is 3000). If the remote AE still continues sending results then ACOM.Rec will (after another 30 results received) abort the association.

The Find SCU interprets following status codes:

Service Status	Further Meaning	Status Codes	Related Fields
Refused	Out of Resources	A700	(0000,0902)
Failed	Identifier does not match SOP Class	A900	(0000,0901) (0000,0902)
	Unable to process	Cxxx	(0000,0901) (0000,0902)
Cancel	Matching terminated due to Cancel request	FE00	None

Success	Matching is complete - No final Identifier is supplied.	0000	None
Pending	Matches are continuing - Current Match is supplied and any Optional Keys were supported in the same manner as Required Keys.	FF00	Identifier
	Matches are continuing - Warning that one or more Optional Keys were not supported for existence and/or matching for this Identifier.	FF01	Identifier

After ACOM.Rec application has received the C-FIND response with Status 'Success' then it will close both associations. Same is true after Status 'Cancel' when ACOM.Rec had previously issued a C-FIND-CANCEL request.

### 3.3.2.4 Associated Real-World Activity - Retrieve SCU

The associated Real-World activity is a C-MOVE request initiated by User Interface of the ACOM.Rec application. In the browsing User Interface one or more patients/studies/series can be selected and asked to be retrieved from the remote Application Entity.

ACOM.Rec will try to establish an association to the remote Application Entity and request the one or more series (based on selection) to be transferred to ACOM.Rec.

Then the ACOM.Rec DICOM application waits for the new association from the remote AE and for the images to be transferred. The images are stored to Local hard disk. After all images are transferred and the association closed by the remote AE the ACOM.Rec Browsing User Interface is updated automatically.

If the C-MOVE Response from the remote Application contains an error status the association is aborted.

### 3.3.2.5 Proposed Presentation Contexts – Retrieve SCU

The Siemens DICOM application will propose Presentation Contexts as shown in the following table

Presentation Context Table					
Abstract Syntax		Transfer Syntax		Role	Extended Negotiation
Name	UID	Name List	UID List		
Study Root Query/Retrieve Move	1.2.840.10008.5.1.4.1.2.2.2	DICOM Explicit VR Little Endian	1.2.840.10008.1.2.1	SCU	None
		DICOM Explicit VR Big Endian	1.2.840.10008.1.2.2		
		DICOM Implicit VR Little Endian	1.2.840.10008.1.2		

Note: C-MOVE Extended Negotiation will NOT be supported by the SCU.

### 3.3.2.6 SOP Specific Conformance Statement– Retrieve SCU

The Siemens DICOM Query/Retrieve SCU supports hierarchical queries with all mandatory search keys. The following tables describe the search keys for the supported query model that the Siemens Query application supports as an SCU:

**STUDY LEVEL KEYS FOR THE STUDY ROOT QUERY/RETRIEVE INFORMATION MODEL:**  
Query Level (0008,0052) = STUDY

Attribute Description	Tag	Type	Matching	User input	Return value displayed
Study Instance UID	(0020,000D)	U	List of UID	Select from list	-

**SERIES LEVEL KEYS FOR THE STUDY ROOT QUERY/RETRIEVE INFORMATION MODEL:**  
Query Level (0008,0052) = SERIES

Attribute Description	Tag	Type	Matching	User input	Return value displayed
Series Instance UID	(0020,000E)	U	List of UID	Select from list	-
From Study level					
Study Instance UID	(0020,000D)	U	Single value	Select from list	-

**INSTANCE LEVEL KEYS FOR THE STUDY ROOT QUERY/RETRIEVE INFORMATION MODEL:**  
Query Level (0008,0052) = IMAGE

Attribute Description	Tag	Type	Matching	User input	Return value displayed
SOP Instance UID	(0008,0018)	U	List of UID	-	-
From Study and Series level					
Study Instance UID	(0020,000D)	U	Single value	Select from list	-
Series Instance UID	(0020,000E)	U	Single value	Select from list	-

The ACOM.Rec Application does not issue a C-MOVE-Cancel request.

A separate C-MOVE request is issued for each series.

The Retrieve can be aborted by deleting the open jobs in the transfer queue. ACOM.Rec will then finish the current C-MOVE for the current series but not issue any new C-MOVE requests.

The Move SCU interprets following status codes:

Service Status	Further Meaning	Status Codes	Related Fields
Refused	Out of Resources – Unable to calculate number of matches	A701	(0000,0902)
	Out of Resources – Unable to perform sub-operations	A702	(0000,1020) (0000,1021) (0000,1022) (0000,1023)
	Move Destination unknown	A801	(0000,0902)
Failed	Identifier does not match SOP Class	A900	(0000,0901) (0000,0902)
	Unable to Process	Cxxx	(0000,0901) (0000,0902)
Cancel	Sub-operations terminated due to Cancel Indication	FE00	(0000,1020) (0000,1021) (0000,1022) (0000,1023)
Warning	Sub-operations Complete - One or more Failures	B000	(0000,1020) (0000,1022) (0000,1023)
Success	Sub-operations Complete - No Failures	0000	(0000,1020) (0000,1021) (0000,1022) (0000,1023)
Pending	Sub-operations are continuing	FF00	(0000,1020) (0000,1021) (0000,1022) (0000,1023)

ACOM.Rec will display a Success message at its user interface only after receiving the C-MOVE Response status of 'Success'.

## 3.4 Communication Profiles

### 3.4.1 Supported Communication Stacks (part 8)

The DICOM Interface of the ACOM.Rec® provides DICOM TCP/IP Network Communication Support as defined in Part 8 of the DICOM Standard.

### 3.4.2 TCP/IP Stack

The DICOM Interface of the ACOM.Rec® uses the TCP/IP stack from the operating system upon which executes. It uses the MergeCOM subroutine library.

### 3.4.3 Physical Media Support

The DICOM Interface of the ACOM.Rec® is indifferent to the physical medium over which TCP/IP executes; it inherits this from the Windows NT operating system upon which it executes.

## 3.5 Extensions/Specializations/Privatizations

### 3.5.1 Standard Extended / specialized / Private SOPs

See section 4.3 on page 48

### 3.5.2 Private Transfer Syntaxes

None.

## 3.6 Configuration

### 3.6.1 AE Title/Presentation Address Mapping

The DICOM Application Entity Title of the own Siemens ACOM.Rec® application and the Application Entity Titles for the remote applications are configurable in the configuration pages. There also the port numbers are configured, default for the own application is port 104.

### 3.6.2 Configurable Parameters

The Application Entity Titles, Host names and Port numbers are configured using the configuration pages. For a description please see the user manual.

In the configuration User Interface of ACOM.Rec a DICOM Test can be performed. If the Test button is pressed then ACOM.Rec will issue first a C-ECHO request and if successful also a C-FIND request.

### 3.6.3 Number of Simultaneous Associations

ACOM.Rec® supports multiple associations at a time.

### 3.6.4 Maximum PDU Size

- max PDU size: 28 kB

### 3.6.5 Time Out

- time-out until a SCP has to accept/reject an association request: 240 sec
- time-out for responding to an association open request: 240 sec
- time-out for responding to an association close request: 240 sec
- time-out for a network write to be accepted: 120 sec
- time-out for data between TCP/IP packets when receiving a message: 120 sec
- time-out for accepting a message over network: 120 sec
- SCU-timeout waiting for Response message: 120 sec
- SCP-timeout for waiting for the next message after sending response: 120 sec

## 3.7 Support of Extended Character Sets

ISO-IR 100 (ISO 8859-1 Latin Alphabet N 1)

## 4. Media Storage

The ACOM.Rec® DICOM off-line media storage service implementation acts as FSC, FSU and FSR for the specified application profiles and the related SOP Class instances.

### 4.1 Implementation Model

#### 4.1.1 Application Data Flow Diagram

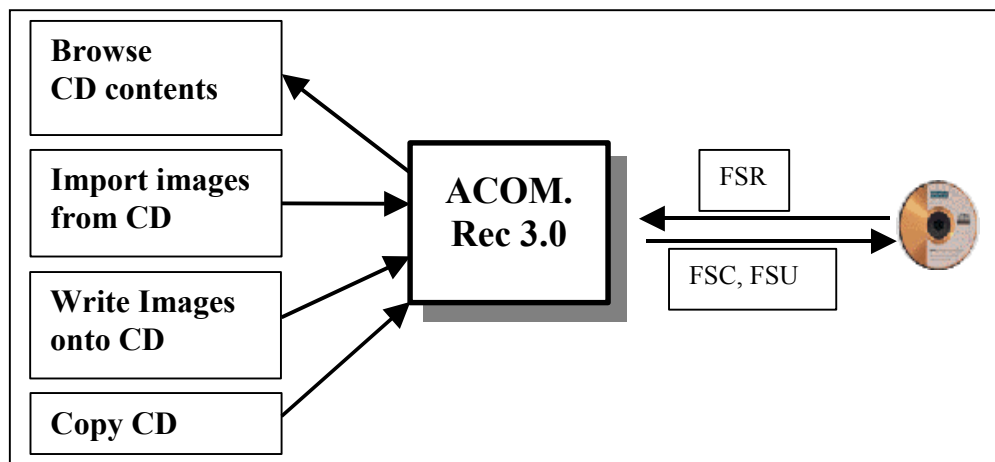

The ACOM.Rec® application will serve as an interface to the CD-R off-line medium device for the ACOM.PC® application to create interchange media. It can write SOP instances to a medium or copy a DICOM CD directly onto an empty CD-R medium.

#### 4.1.2 Functional Definition of AE

The ACOM.Rec® product DICOM off-line media storage application consists all interfaces to access off-line media. It is capable of

- creating a new File-set onto an unwritten CD-R medium.
- Updating an existing File-set by writing new SOP Instances onto the medium.
- Reading the File-sets DICOMDIR information temporarily into the browser.
- Importing the File-sets from CD into local storage or transfer to DICOM destination
- Copy an existing medium directly onto an empty CD-R medium.

#### 4.1.3 Sequencing of Real World Activities

The ACOM.Rec® VA03A application will not perform updates before the Directory information of the DICOMDIR is completely read.

#### 4.1.4 File Meta Information Options

Implementation Class UID	"1.3.12.2.1107.5.4.9.40"
Implementation Version Name	"ACOM_PC_40"

## 4.2 AE Specification

### 4.2.1 DICOM Archive Specification

The ACOM.Rec® Application provides Standard conformance to Media Storage Service Class (Interchange Option).

*Application profiles, Activities, and Roles for DICOM Archive*

Application Profiles Supported	Real World Activity	Role	SC Option
STD-XABC-CD AUG-XABC-DYNAMIC-CD	Browse Directory Information	FSR	Interchange
STD-XA1k-CD AUG-GEN-CD PRI-AREC-CD	Export to local archive media	FSC, FSU	Interchange
	Copy existing media onto new one	FSC	Interchange

The STD-XABC-CD application profile is used when writing images from the ACOM.PC® local directory onto a CD-R or also when copying a CD written in STD-XABC-CD profile. The augmented AUG-XABC-DYNAMIC-CD profile is only used when copying CDs written in AUG-XABC-DYNAMIC-CD profile (for example by an ACOM.M® product).

#### 4.2.1.1 File Meta Information for the Application Entity

The Source Application Entity Title is set to the AET of the ACOM.Rec application (own AET of the Storage SCP, configurable).

#### 4.2.1.2 Real-World Activities for this Application Entity

##### 4.2.1.2.1 Real-World Activity: Browse Directory Information

The ACOM.Rec® application acts as FSR and reads the DICOMDIR file as soon as a DICOM CD is inserted into the drive. The DICOMDIR contents are evaluated and the Patients listed in the Patient Browser. When a Patient entry is selected in this Patient Browser then the corresponding information about the studies on CD is displayed in the Browser. If Detached Patient Management objects are present then the new values from those objects take precedence over the image attributes.

#### 4.2.1.2.2 Real-World Activity: Import Images from CD-ROM

The ACOM.Rec® application acts as FSR when requested to read images from CD-ROM device to the local storage or a network drive or to transfer to a DICOM destination.

If Detached Patient Management objects are present then the new values from those objects take precedence over the image attributes when the images are sent over network. When importing into local storage or network drive the Detached Patient Management objects are also imported without change.

#### 4.2.1.2.3 Real-World Activity: Export to local Archive Media

The ACOM.Rec® application acts as an FSU (for media with existing DICOM file-set) or FSC (for not-initialized media) when requested to write Images to the local archive medium (only CD-R supported). In case of new media (media not initialized) it will create a DICOMDIR file on the medium or otherwise (already existing DICOM file-set on medium) it will update the existing DICOMDIR file when writing the new SOP Instances to medium. ACOM.Rec allows anonymizing the data when writing onto CD-R media (see separate section 4.2.4 for more details).

The ACOM.Rec® application will not close the CD-R medium.

ACOM.Rec® can also burn a DICOM viewer onto the CD with the images. This DICOM viewer will be automatically started when such a CD is inserted into a PC which has the autostart option enabled for the CD-ROM drive and does not have the ACOM.PC® Viewer installed.

#### 4.2.1.2.4 Real-World Activity: Copy Media

The ACOM.Rec® application acts as an FSC when requested to copy a local medium (CD-ROM) onto a new empty archive medium (only CD-R supported). It will copy all files (including DICOMDIR) without modification.

But the ACOM.Rec® application will copy only media containing DICOM File-sets so at least a DICOMDIR file has to be present otherwise the copy operation will be rejected.

### 4.2.2 Application profiles

#### 4.2.2.1 DICOMDIR keys

The DICOMDIR file will contain the following attributes for the levels Patient – Study – Series – Image/Waveform/Private for the new SOP instances written by ACOM.Rec® application:

*DICOMDIR keys:*

Attribute Name	Tag	Type	Notes
<b>File-Set Meta information</b>			
File Meta Information Version	(0002,0001)	1	00 01
Media Storage SOP Class UID	(0002,0002)	1	Media Storage Directory SOP Class

Media Storage SOP Instance UID	(0002,0003)	1	
Transfer Syntax UID	(0002,0010)	1	Explicit VR Little Endian
Implementation Class UID	(0002,0012)	1	
Implementation Version Name	(0002,0013)	3	
Source Application Entity Title	(0002,0016)	3	ACOM_REC_20
<b>File-Set identification</b>			
File-set ID	(0004,1130)	2	ACOM_PC_40
<b>Directory information</b>			
Offset of the First Directory Record of the Root Directory Entry	(0004,1200)	1	
Offset of the Last Directory Record of the Root Directory Entity	(0004,1202)	1	
File-set Consistency Flag	(0004,1212)	1	0000H
Directory Record Sequence	(0004,1220)	2	
> Offset of the Next Directory Record	(0004,1400)	1C	
> Record In-use flag	(0004,1410)	1C	FFFFH
> Offset of Referenced Lower-Level Directory Entity	(0004,1420)	1C	
> Directory Record Type	(0004,1430)	1C	PATIENT, STUDY, SERIES, IMAGE, PRIVATE, WAVEFORM
> Private Record UID	(0004,1432)	1C	Required for Directory Record type PRIVATE
> Referenced File ID	(0004,1500)	1C	contains the filename on media for the Directory Record of Type IMAGE or PRIVATE
> Referenced SOP Class UID in File	(0004,1510)	1C	for the Directory Record of Type IMAGE or PRIVATE
> Referenced SOP Instance UID in File	(0004,1511)	1C	for the Directory Record of Type IMAGE or PRIVATE
> Referenced Transfer Syntax UID in File	(0004,1512)	1C	for the Directory Record of Type IMAGE or PRIVATE
> Record Selection Keys	see below		
<b>Patient Keys</b>			<b>Directory Record Type PATIENT</b>
Specific Character Set	(0008,0005)	1C	
Patient's Name	(0010,0010)	2	
Patient ID	(0010,0020)	1	
Date Of Birth	(0010,0030)	2	
Patient's Sex	(0010,0040)	2	
<b>Study Keys</b>			<b>Directory Record Type STUDY</b>
Specific Character Set	(0008,0005)	1C	
Study Date	(0008,0020)	1	

Study Time	(0008,0030)	1	
Accession Number	(0008,0050)	2	
Referring Physician's Name	(0008,0090)	3	
Study Description	(0008,1030)	2	
PrivateCreator	(0009,0010)	3	“CARDIO-SMS 1.0“
ACOM flags	(0009,1008)	3	Hex 7\10004\10004\7
Study Instance UID	(0020,000D)	1	
Study ID	(0020,0010)	1	Must be filled by data set creator
<b>Series Keys</b>			<b>Directory Record Type SERIES</b>
Specific Character Set	(0008,0005)	1C	
Modality	(0008,0060)	1	
Institution name	(0008,0080)	2	
Institution Address	(0008,0081)	2	Required by STD-XABC-CD profile
Performing Physician's Name	(0008,1050)	2	
Series Instance UID	(0020,000E)	1	
Series Number	(0020,0011)	1	
<b>Image Keys</b>			<b>Directory Record Type IMAGE</b>
Specific Character Set	(0008,0005)	1C	
Image Type	(0008,0008)	1	
Referenced Image Sequence	(0008,1140)	1C	Required if associated Biplane image exists
> Referenced SOP Class UID	(0008,1150)	1C	
> Referenced SOP Instance UID	(0008,1155)	1C	
SOP Class UID	(0008,1150)	3	
SOP Instance UID	(0008,1155)	3	
Private Creator	(0009,0010)	1C	“CARDIO-D.R. 1.0” required if Alternate Image Sequence is present
Alternate Image Sequence	(0009,xx40)	1C	Required by AUG-XABC-DYNAMIC-CD profile if associated Lossy Directory Record exists
> Referenced SOP Class UID	(0008,1150)	1C	
> Referenced SOP Instance UID	(0008,1155)	1C	
Frame Time	(0018,1063)	3	
Positioner Motion	(0018,1500)	3	Used in AUG-XABC-DYNAMIC-CD profile
Positioner Primary Angle	(0018, 1510)	3	
Positioner Secondary Angle	(0018, 1511)	3	
Image Number	(0020,0013)	1	
Number of Frames	(0028,0008)	3	

Frame Increment Pointer	(0028,0009)	3	
Calibration image	(0050,0004)	2	Required by STD-XABC-CD profile
Icon Image Sequence	(0088,0200)	1	Required for STD-XABC-CD Application profile
> Samples per Pixel	(0028,0002)		1
> Photometric Interpretation	(0028,0004)		MONOCHROME2 or Palette Color (for US)
> Rows	(0028,0010)		128 if image rows or columns is > 128, 64 otherwise
> Columns	(0028,0011)		128 if image rows or columns is > 128, 64 otherwise
> Bits Allocated	(0028,0100)		8
> Bits Stored	(0028,0101)		8
> High Bit	(0028,0102)		7
> Pixel Representation	(0028,0103)		0 (unsigned)
> Pixel Data	(7FE0,0010)		Icon Image pixel data
<b>Dynaview Image Keys</b>			<b>Directory Record Type PRIVATE</b>
Specific Character Set	(0008,0005)	1C	
Image Type	(0008,0008)	1	
Referenced Image Sequence	(0008,1140)	1C	Required if associated Biplane image exists
> Referenced SOP Class UID	(0008,1150)	1C	
> Referenced SOP Instance UID	(0008,1155)	1C	
Source Image Sequence	(0008,2112)	1	Required by AUG-XABC-DYNAMIC-CD profile for lossy Dynaview image to reference the corresponding JPEG lossless compressed image
> Referenced SOP Class UID	(0008,1150)	1C	
> Referenced SOP Instance UID	(0008,1155)	1C	
Frame Time	(0018,1063)	3	
Positioner Motion	(0018,1500)	3	
Positioner Primary Angle	(0018,1510)	3	
Positioner Secondary Angle	(0018,1511)	3	
Image Number	(0020,0013)	1	
Number of Frames	(0028,0008)	3	
Icon Image Sequence	(0088,0200)	3	Optional in AUG-XABC-DYNAMIC-CD Application profile
> Samples per Pixel	(0028,0002)		1
> Photometric Interpretation	(0028,0004)		MONOCHROME2
> Rows	(0028,0010)		128
> Columns	(0028,0011)		128
> Bits Allocated	(0028,0100)		8
> Bits Stored	(0028,0101)		8

> High Bit	(0028,0102)		7
> Pixel Representation	(0028,0103)		0 (unsigned)
> Pixel Data	(7FE0,0010)		Icon Image pixel data
<b>Waveform Keys</b>			<b>Directory Record Type WAVEFORM</b>
Specific Character Set	(0008,0005)	1C	
Content Date	(0008,0023)	1	
Content Time	(0008,0033)	1	
Instance Number	(0020,0013)	1	
<b>HICOR/ACOM Report Keys</b>			<b>Directory Record Type PRIVATE</b>
Specific Character Set	(0008,0005)	1C	
Image Type	(0008,0008)	1	“ORIGINAL\PRIMARY\SINGLE PLANE\SINGLE A”
Positioner Motion	(0018,1500)	3	NULL length
Positioner Primary Angle	(0018, 1510)	3	
Positioner Secondary Angle	(0018, 1511)	3	
Image Number	(0020,0013)	1	
Number of Frames	(0028,0008)	3	“1” (stored as XA IOD with only one frame)
<b>syngo CsaNonImage Keys</b>			<b>Directory Record Type IMAGE</b>
Specific Character Set	(0008,0005)	1C	
Image Type	(0008,0008)	3	
Acquisition Number	(0020,0012)	3	
Private Creator	(0029,0010)	1	“SIEMENS CSA NON-IMAGE”
Syngo Data Type	(0029,1008)	1	Syngo Data identification
Syngo Data Version	(0029,1009)	3	Version information

The AUG-XABC-DYNAMIC-CD Augmented Application Profile utilizes the same requirements for the Directory information in DICOMDIR as the STD-XABC-CD Application Profile with the addition that Directory Records associated with Dynaview Lossy XA Image IODs shall exist as Private Directory Records.

**4.2.2.2 STD-XABC-CD**

For media conforming to the STD-XABC-CD Profile the following SOP classes will be supported:

Information Object Definitions	SOP Class UID	Transfer Syntax and UID	FSC	FSR	FSU

XA Image	1.2.840.10008.5.1.4.1.1.12.1	JPEG lossless Process 14 1.2.840.10008.1.2.4.70	Yes	Yes	Yes
Detached Patient Management	1.2.840.10008.3.1.2.1.1	Explicit VR Little Endian 1.2.840.10008.1.2.1	No	Yes	No

Detached Patient Management IOD is supported when browsing the media contents. ACOM.Rec will automatically merge the Detached Patient Management information into the objects when they are sent over network to other DICOM nodes.

Standalone IODs (Standalone Overlay, Standalone Curve, ..) are not supported.

This profile is used if CARD image data (including HICOR®/ACOM® Images or Reports) are stored from the ACOM.net® server or the ACOM.PC® Local directory onto CD-R.

#### 4.2.2.3 STD-XA1k-CD

For media conforming to the STD-XA1k-CD Profile the following SOP classes will be supported:

Information Object Definitions	SOP Class UID	Transfer Syntax and UID	FSC	FSR	FSU
XA Image	1.2.840.10008.5.1.4.1.1.12.1	JPEG lossless Process 14 1.2.840.10008.1.2.4.70	Yes	Yes	Yes
SC Image	1.2.840.10008.5.1.4.1.1.7	Explicit VR Little Endian 1.2.840.10008.1.2.1	Yes	Yes	Yes
Detached Patient Management	1.2.840.10008.3.1.2.1.1	Explicit VR Little Endian 1.2.840.10008.1.2.1	No	Yes	No

Detached Patient Management IOD is supported when browsing the media contents. ACOM.Rec will automatically merge the Detached Patient Management information into the objects when they are sent over network to other DICOM nodes.

Standalone IODs (Standalone Overlay, Standalone Curve, ..) are not supported.

This profile is used if ANGIO image data (including AXIOM.Artis® or Polytron TOP® 1k<sup>2</sup> Images) are stored from the ACOM.net® server, from AXIOM.Artis or the ACOM.PC® Local directory onto CD-R.

#### 4.2.3 Augmented and Private Profiles

The following Augmented Application Profiles are supported:

#### 4.2.3.1 AUG-XABC-DYNAMIC-CD

This profile extends the STD-XABC-CD application profile to store XA SOP Instances also in JPEG lossy transfer syntax. It is used by HICOR®/ACOM® when writing a patient with Dynaview images onto CD-R. ACOM.Rec® only uses this profile when copying a CD already written in this profile.

For media conforming to the AUG-XABC-DYNAMIC-CD Profile the following SOP classes will be supported:

Information Object Definitions	SOP Class UID	Transfer Syntax and UID	FSC	FSR	FSU
XA Image	1.2.840.10008.5.1.4.1.1.12.1	JPEG lossless Process 14 1.2.840.10008.1.2.4.70  JPEG lossy Process 1 1.2.840.10008.1.2.4.50	Yes	Yes	Yes
Detached Patient Management	1.2.840.10008.3.1.2.1.1	Explicit VR Little Endian 1.2.840.10008.1.2.1	No	Yes	No

Detached Patient Management IOD is supported when browsing the media contents. ACOM.Rec will automatically merge the Detached Patient Management information into the objects when they are sent over network to other DICOM nodes.

#### 4.2.3.2 AUG-GEN-CD

For media conforming to the AUG-GEN-CD Profile the following SOP classes will be supported:

Information Object Definitions	SOP Class UID	Transfer Syntax and UID	FSC	FSR	FSU
XA Image	1.2.840.10008.5.1.4.1.1.1 2.1	Explicit VR Little Endian 1.2.840.10008.1.2.1  JPEG lossless Process 14 1.2.840.10008.1.2.4.70  JPEG lossy Baseline (8bit) 1.2.840.10008.1.2.4.50 JPEG lossy Extended (12bit) 1.2.840.10008.1.2.4.51	Yes	Yes	Yes
Secondary Capture Image	1.2.840.10008.5.1.4.1.1.7	Explicit VR Little Endian 1.2.840.10008.1.2.1  JPEG lossless Process 14	Yes	Yes	Yes

		1.2.840.10008.1.2.4.70  JPEG lossy Baseline (8bit) 1.2.840.10008.1.2.4.50 JPEG lossy Extended (12bit) 1.2.840.10008.1.2.4.51			
Ultrasound Image	1.2.840.10008.5.1.4.1.1.6.1	Explicit VR Little Endian 1.2.840.10008.1.2.1  RLE lossless 1.2.840.10008.1.2.5  JPEG lossless Process 14 1.2.840.10008.1.2.4.70  JPEG lossy Baseline (8bit) 1.2.840.10008.1.2.4.50 JPEG lossy Extended (12bit) 1.2.840.10008.1.2.4.51	Yes	Yes	Yes
Ultrasound Multiframe Image	1.2.840.10008.5.1.4.1.1.3.1	Explicit VR Little Endian 1.2.840.10008.1.2.1  RLE lossless 1.2.840.10008.1.2.5  JPEG lossless Process 14 1.2.840.10008.1.2.4.70  JPEG lossy Baseline (8bit) 1.2.840.10008.1.2.4.50  JPEG lossy Extended (12bit) 1.2.840.10008.1.2.4.51	Yes	Yes	Yes
Ultrasound Image Storage (retired)	1.2.840.10008.5.1.4.1.1.6	Explicit VR Little Endian 1.2.840.10008.1.2.1  JPEG lossless Process 14 1.2.840.10008.1.2.4.70  JPEG lossy Baseline (8bit) 1.2.840.10008.1.2.4.50  JPEG lossy Extended (12bit) 1.2.840.10008.1.2.4.51	Yes	Yes	Yes
Ultrasound Multi-frame Image Storage (retired)	1.2.840.10008.5.1.4.1.1.3	Explicit VR Little Endian 1.2.840.10008.1.2.1  JPEG lossless Process 14	Yes	Yes	Yes

		1.2.840.10008.1.2.4.70  JPEG lossy Baseline (8bit) 1.2.840.10008.1.2.4.50  JPEG lossy Extended (12bit) 1.2.840.10008.1.2.4.51			
Nuclear Medicine Image	1.2.840.10008.5.1.4.1.1.2 0	Explicit VR Little Endian 1.2.840.10008.1.2.1	Yes	Yes	Yes
12-lead ECG Waveform Storage	1.2.840.10008.5.1.4.1.1.9. 1.1	Explicit VR Little Endian 1.2.840.10008.1.2.1	Yes	Yes	Yes
General ECG Waveform Storage	1.2.840.10008.5.1.4.1.1.9. 1.2	Explicit VR Little Endian 1.2.840.10008.1.2.1	Yes	Yes	Yes
Ambulatory ECG Waveform Storage	1.2.840.10008.5.1.4.1.1.9. 1.3	Explicit VR Little Endian 1.2.840.10008.1.2.1	Yes	Yes	Yes
Hemodynamic Waveform Storage	1.2.840.10008.5.1.4.1.1.9. 2.1	Explicit VR Little Endian 1.2.840.10008.1.2.1	Yes	Yes	Yes
Cardiac Electrophysiolog y Waveform Storage	1.2.840.10008.5.1.4.1.1.9. 3.1	Explicit VR Little Endian 1.2.840.10008.1.2.1	Yes	Yes	Yes
Basic Voice Audio Waveform Storage	1.2.840.10008.5.1.4.1.1.9. 4.1	Explicit VR Little Endian 1.2.840.10008.1.2.1	Yes	Yes	Yes
Detached Patient Management	1.2.840.10008.3.1.2.1.1	Explicit VR Little Endian 1.2.840.10008.1.2.1	No	Yes	No

Detached Patient Management IOD is supported when browsing the media contents. ACOM.Rec will automatically merge the Detached Patient Management information into the objects when they are sent over network to other DICOM nodes.

Standalone IODs (Standalone Overlay, Standalone Curve, ..) are not supported.

This profile augments the STD-GEN-CD profile as it also allows to store XA and SC images with JPEG lossless transfer syntax and US images with RLE lossless, JPEG lossless or lossy transfer syntax.

This profile is used if patient data are to be stored from the ACOM.net® server or the ACOM.PC® Local directory onto CD-R which contain Ultrasound, Nuclear Medicine or Secondary Capture images or Waveform objects.

### 4.2.3.3 Private Application Profiles PRI-AREC-CD

For media conforming to the PRI-AREC-CD Profile the following SOP classes will be supported:

Information Object Definitions	SOP Class UID	Transfer Syntax and UID	FSC	FSR	FSU
XA Image	1.2.840.10008.5.1.4.1.1.1 2.1	Explicit VR Little Endian 1.2.840.10008.1.2.1  JPEG lossless Process 14 1.2.840.10008.1.2.4.70  JPEG lossy Baseline (8bit) 1.2.840.10008.1.2.4.50  JPEG lossy Extended (12bit) 1.2.840.10008.1.2.4.51	Yes	Yes	Yes
Secondary Capture Image	1.2.840.10008.5.1.4.1.1.7	Explicit VR Little Endian 1.2.840.10008.1.2.1  JPEG lossless Process 14 1.2.840.10008.1.2.4.70  JPEG lossy Baseline (8bit) 1.2.840.10008.1.2.4.50  JPEG lossy Extended (12bit) 1.2.840.10008.1.2.4.51	Yes	Yes	Yes
Ultrasound Image	1.2.840.10008.5.1.4.1.1.6. 1	Explicit VR Little Endian 1.2.840.10008.1.2.1  RLE lossless 1.2.840.10008.1.2.5  JPEG lossless Process 14 1.2.840.10008.1.2.4.70  JPEG lossy Baseline (8bit) 1.2.840.10008.1.2.4.50 JPEG lossy Extended (12bit) 1.2.840.10008.1.2.4.51	Yes	Yes	Yes
Ultrasound Multiframe Image	1.2.840.10008.5.1.4.1.1.3. 1	Explicit VR Little Endian 1.2.840.10008.1.2.1  RLE lossless 1.2.840.10008.1.2.5	Yes	Yes	Yes

		JPEG lossless Process 14 1.2.840.10008.1.2.4.70			
		JPEG lossy Baseline (8bit) 1.2.840.10008.1.2.4.50 JPEG lossy Extended (12bit) 1.2.840.10008.1.2.4.51			
Ultrasound Image Storage (retired)	1.2.840.10008.5.1.4.1.1.6	Explicit VR Little Endian 1.2.840.10008.1.2.1  JPEG lossless Process 14 1.2.840.10008.1.2.4.70  JPEG lossy Baseline (8bit) 1.2.840.10008.1.2.4.50 JPEG lossy Extended (12bit) 1.2.840.10008.1.2.4.51	Yes	Yes	Yes
Ultrasound Multi-frame Image Storage (retired)	1.2.840.10008.5.1.4.1.1.3	Explicit VR Little Endian 1.2.840.10008.1.2.1  JPEG lossless Process 14 1.2.840.10008.1.2.4.70  JPEG lossy Baseline (8bit) 1.2.840.10008.1.2.4.50 JPEG lossy Extended (12bit) 1.2.840.10008.1.2.4.51	Yes	Yes	Yes
Nuclear Medicine Image	1.2.840.10008.5.1.4.1.1.20	Explicit VR Little Endian 1.2.840.10008.1.2.1	Yes	Yes	Yes
12-lead ECG Waveform Storage	1.2.840.10008.5.1.4.1.1.9.1.1	Explicit VR Little Endian 1.2.840.10008.1.2.1	Yes	Yes	Yes
General ECG Waveform Storage	1.2.840.10008.5.1.4.1.1.9.1.2	Explicit VR Little Endian 1.2.840.10008.1.2.1	Yes	Yes	Yes
Ambulatory ECG Waveform Storage	1.2.840.10008.5.1.4.1.1.9.1.3	Explicit VR Little Endian 1.2.840.10008.1.2.1	Yes	Yes	Yes
Hemodynamic Waveform Storage	1.2.840.10008.5.1.4.1.1.9.2.1	Explicit VR Little Endian 1.2.840.10008.1.2.1	Yes	Yes	Yes
Cardiac Electrophysiology Waveform Storage	1.2.840.10008.5.1.4.1.1.9.3.1	Explicit VR Little Endian 1.2.840.10008.1.2.1	Yes	Yes	Yes
Basic Voice Audio Waveform Storage	1.2.840.10008.5.1.4.1.1.9.4.1	Explicit VR Little Endian 1.2.840.10008.1.2.1	Yes	Yes	Yes

CSA Non-Image	1.3.12.2.1107.5.9.1	Explicit VR Little Endian 1.2.840.10008.1.2.1	Yes	Yes	Yes
Detached Patient Management	1.2.840.10008.3.1.2.1.1	Explicit VR Little Endian 1.2.840.10008.1.2.1	Yes	Yes	Yes

Detached Patient Management IOD is supported when browsing the media contents. ACOM.Rec will automatically merge the Detached Patient Management information into the objects when they are sent over network to other DICOM nodes.

#### 4.2.4 Anonymizing of patient data

ACOM.Rec 3,0 can also write patient data in an anonymized way onto CD-R media. The DICOM data are modified on the fly according to following table:

Attribute Name	Tag	Type	Change
Instance Creator UID	(0008,0014)	3	Attribute deleted
SOP Instance UID	(0008,0018)		New value
Accession Number	(0008,0050)	2	Value deleted
Institution Name	(0008,0080)	2	Value deleted
Institution Address	(0008,0081)	2	Value deleted
Referring Physician's Name	(0008,0090)	3	Attribute deleted
Referring Physician's Address	(0008,0092)		Value deleted
Referring Physician's Telephone Numbers	(0008,0094)		Value deleted
Station Name	(0008,1010)	3	Attribute deleted
Study Description	(0008,1030)	2	Remains unchanged
Series Description	(0008,103E)	3	Remains unchanged
Institutional Department Name	(0008,1040)	3	Remains unchanged
Physician(s) of Record	(0008,1048)	3	Attribute deleted
Performing Physicians' Name	(0008,1050)	2	Value deleted
Name of Physician(s) Reading Study	(0008,1060)	3	Attribute deleted
Operators' Name	(0008,1070)	2	Value deleted
Admitting Diagnoses Description	(0008,1080)	3	Attribute deleted
Referenced SOP Instance UID	(0008,1155)	1C	Value deleted
Derivation Description	(0008,2111)	3	Attribute deleted
Patient's Name	(0010,0010)	2	From user input (Default: "").
Patient ID	(0010,0020)	1	From user input (Default: "xx").
Patient's Birth Date	(0010,0030)	2	Value is deleted but before the patient's Age is calculated and stored in Patient's Age (0010,1010)
Patient's Birth Time	(0010,0032)	3	Attribute deleted
Patient's Sex	(0010,0040)	2	Remains unchanged
Other Patient Ids	(0010,1000)	3	Attribute deleted
Other Patient Names	(0010,1001)	3	Attribute deleted

Attribute Name	Tag	Type	Change
Patient's Age	(0010,1010)	3	Calculated from Patient's Birth Date (0010,0030)
Patient's Size	(0010,1020)	3	Remains unchanged
Patient's Weight	(0010,1030)	3	Remains unchanged
Patient's Address	(0010,1040)	3	Attribute deleted
Military Rank	(0010,1080)	3	Attribute deleted
Medical Record Locator	(0010,1090)		Value deleted
Ethnic Group	(0010,2160)	3	Attribute deleted
Occupation	(0010,2180)	3	Attribute deleted
Additional Patient's History	(0010,21B0)	3	Attribute deleted
Patient Comments	(0010,4000)	3	Attribute deleted
Device Serial Number	(0018,1000)	2 or 3	Value deleted
Protocol Name	(0018,1030)	3	Attribute deleted
Study Instance UID	(0020,000D)	1	New UID created
Series Instance UID	(0020,000E)	1	New UID created
Study ID	(0020,0010)	1	Changed to "xx"
Frame of Reference UID	(0020,0052)	1 or 1C	Value deleted
Synchronization Frame of Reference UID	(0020,0200)	1	Value deleted
Image Comments	(0020,4000)	3	Attribute deleted
Requesting Physician	(0032,1032)	3	Attribute deleted
Request Attributes Sequence	(0040,0275)	3	Attribute deleted
UID	(0040,A124)	1C	Value deleted
Content Sequence	(0040,A730)	1C	Value deleted
Storage Media File-set UID	(0088,0140)	2C or 3	Value deleted
Referenced Frame of Reference UID	(3006,0024)	1C	Value deleted
Related Frame of Reference UID	(3006,00C2)	1C	Value deleted

## 4.3 Extensions, Specializations and Privatizations of SOP Classes and Transfer Syntaxes

### 4.3.1 Standard Extensions of XA Storage SOP classes

When exchanged under the AUG-XABC-DYNAMIC-CD Augmented Application Profile, the lossless and lossy XA image IODs shall contain, in addition to the attributes required for the XA image IOD in the STD-XABC-CD application profile, the attributes listed in the following table:

Attribute Name	Tag	Type (lossless)	Type (lossy)	Notes
<b>Edge Enhancement Sequence</b>	(0029,xx00)	1	1	Private Creator "CARDIO-D.R. 1.0"
> Private Creator	(0029,00xx)	1	1	"CARDIO-D.R. 1.0"
> Convolution Kernel Size	(0029,xx01)	1	1	Number of rows/columns in the convolution kernel
> Convolution Kernel coefficients	(0029,xx02)	1	1	The coefficients organized by row from left to right starting with the top row.
> Edge Enhancement Gain	(0029,xx03)	1	1	
<b>Alternate Image Sequence</b>	(0009,xx40)	1	-	Used in lossless image to reference the corresponding lossy image
> Referenced SOP Class UID	(0008,1150)	1		
> Referenced SOP Instance UID	(0008,1155)	1		
<b>Source Image Sequence</b>	(0008,2112)	-	1	Used in lossy image to reference the corresponding lossless image
> Referenced SOP Class UID	(0008,1150)		1	
> Referenced SOP Instance UID	(0008,1155)		1	

### 4.3.2 Private Storage SOP classes

#### 4.3.2.1 Extension, Specialization for SIEMENS Non-Image Objects

The Private Creator UIDs and further optional keys for the Directory Records referring to SIEMENS Non-Image Objects are listed in the following tables.

Attribute	Tag	Value used
Private Record UID	(0004,1432)	1.3.12.2.1107.5.9.1
SOP Class UID	(0008,0016)	1.3.12.2.1107.5.9.1

For those "Non-Images" no Icon Image Sequence will be included in the DICOMDIR. No further optional keys for the directory Records inside the DICOMDIR will be used.

The Non-Image object is described in detail in the Appendix.

### 4.3.3 Private Transfer Syntaxes

Not applicable

## **4.4 Configuration**

### **4.4.1 AE Title Mapping**

When creating a new File-set on media or updating an existing File-set then ACOM.Rec® will set the Source Application Entity Title in the DICOMDIR to the AET of the own ACOM.Rec® application (own AET of the Storage SCP, configurable).

## **4.5 Support of Extended Character Sets**

ISO-IR 100 (ISO 8859-1:1987 Latin Alphabet N 1. supplementary set)

## **A APPENDIX**

### **A.1 SIEMENS Private syngo Non-Image IOD**

For encoding binary data-streams not representing image data, Siemens has created a private "Non-Image IOD" according to the rules governed by the DICOM Standard. The following section will roll-out the definition of this Private IOD. It can be communicated with Network Storage Service and Offline Media Storage Services.

The Siemens "Non-Image IOD" is identified by a private Non-Image Storage SOP Class UID of "1.3.12.2.1107.5.9.1"

#### **A.1.1 Siemens syngo Non-Image IOD – E-R Model**

The E-R model in A.1.2 depicts those components of the DICOM Information Model which directly refer to the Siemens Non-Image IOD. The Frame of Reference IE, Overlay IE, Modality Lookup-Table IE, VOI Lookup-Table IE and Curve IE are not components of the Siemens Non-Image IOD.

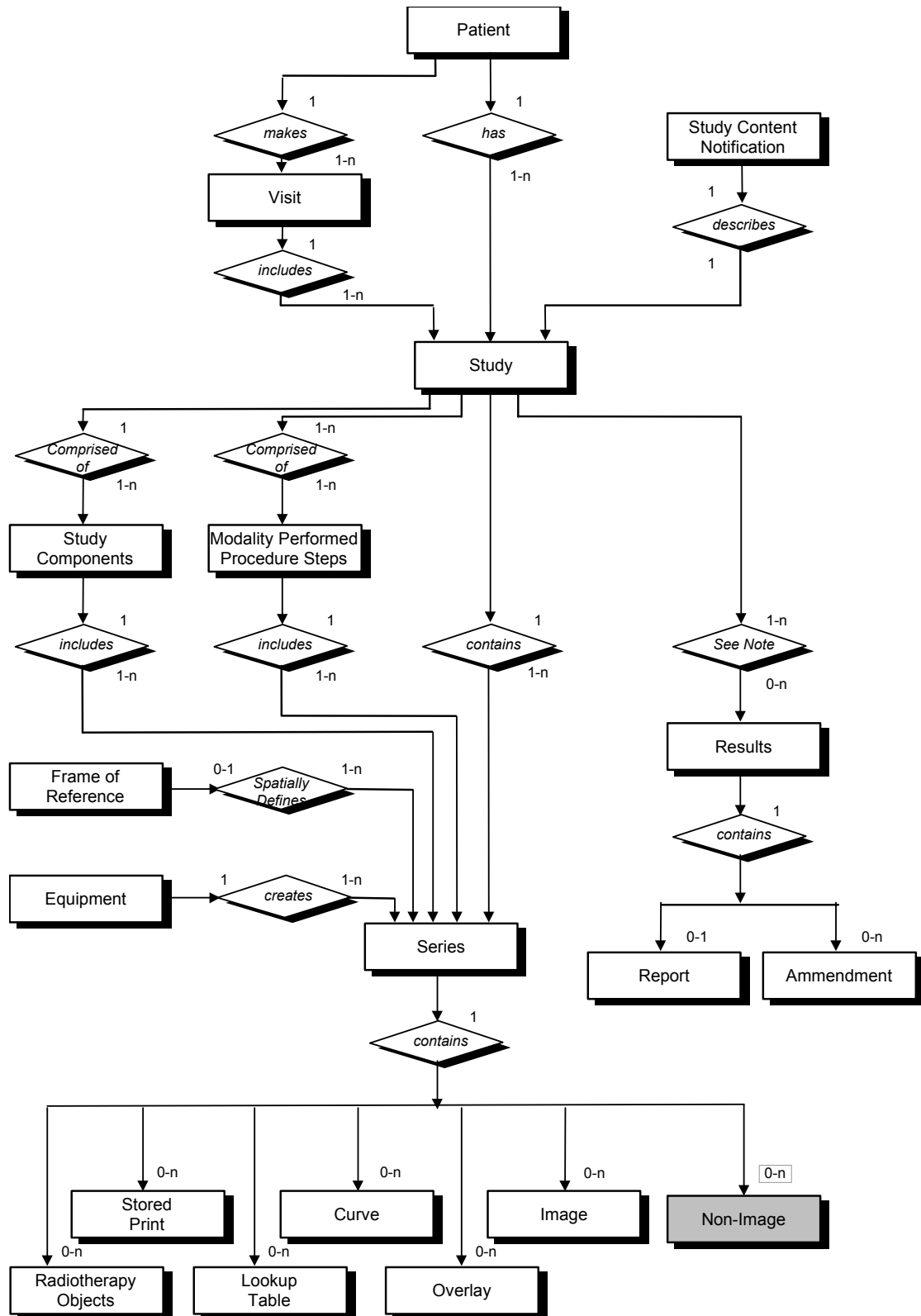

## A.1.2 Siemens syngo Non-Image IOD - Module Table

IE	Module	Reference	Usage
Patient	Patient	[DICOM] PS3.3 C.7.1.1	M
Study	General Study	[DICOM] PS3.3 C.7.2.1	M
	Patient Study	[DICOM] PS3.3 C.7.2.2	U
Series	General Series	[DICOM] PS3.3 C.7.3.1	M
Equipment	General Equipment	[DICOM] PS3.3 C.7.5.1	U
CSA	CSA Image Header	A.2.1	U
	CSA Series Header	A.2.2	U
	MEDCOM Header	A.2.3	U
	CSA Non-Image	A.1.3.1	M
	SOP Common	[DICOM] PS3.3 C.12.1	M

## A.1.3 Siemens syngo Non-Image IOD - Modules

### A.1.3.1 CSA Non-Image Module

The table in this section contains private IOD Attributes that describe CSA Non-Images.

Attribute Name	Tag	Owner	Type	Notes
Image Type	(0008,0008)	-	3	Image identification characteristics.
Acquisition Date	(0008,0022)	-	3	The date the acquisition of data that resulted in this data set started.
Acquisition Time	(0008,0023)	-	3	The time the acquisition of data that resulted in this data set started.
Derivation Description	(0008,2111)	-	3	A text description of how this data set was derived.
Acquisition Number	(0020,0012)	-	3	A number identifying the single continuous gathering of data over a period of time which resulted in this data set.
CSA Data Type	(0029,xx08)	SIEMENS CSA NON-IMAGE	1	CSA Data identification characteristics. Defined Terms: BSR REPORT = Study Report Data
CSA Data Version	(0029,xx09)	SIEMENS CSA NON-IMAGE	3	Version of CSA Data Info (0029,xx10) format and CSA Non-Image Data (7FE1,xx10) format.
CSA Data Info	(0029,xx10)	SIEMENS CSA NON-IMAGE	3	Information to describe the CSA Data (7FE1,xx10).
CSA Data	(7FE1,xx10)	SIEMENS CSA NON-IMAGE	2	Binary data as byte stream.

## A.2 Siemens Standard Extended Modules

### A.2.1 CSA Image Header Module

The table in this section contains private IOD Attributes that describe the CSA Image Header:

Attribute Name	Tag	Owner	Type	Notes
CSA Image Header Type	(0029,xx08)	SIEMENS CSA HEADER	1	CSA Image Header identification characteristics.
CSA Image Header Version	(0029,xx09)	SIEMENS CSA HEADER	3	Version of CSA Image Header Info (0029,xx10) format.
CSA Image Header Info	(0029,xx10)	SIEMENS CSA HEADER	3	Manufacturer model dependent information.

### A.2.2 CSA Series Header Module

The table in this section contains private IOD Attributes that describe the CSA Series Header:

Attribute Name	Tag	Owner	Type	Notes
CSA Series Header Type	(0029,xx28)	SIEMENS CSA HEADER	1	CSA Series Header identification characteristics.
CSA Series Header Version	(0029,xx29)	SIEMENS CSA HEADER	3	Version of CSA Series Header Info (0029,xx10) format.
CSA Series Header Info	(0029,xx20)	SIEMENS CSA HEADER	3	Manufacturer model dependent information.

### A.2.3 MEDCOM Header Module

The table in this section contains private IOD Attributes that describe MEDCOM Header:

Attribute Name	Tag	Owner	Type	Notes
MedCom Header Type	(0029,xx08)	SIEMENS MEDCOM HEADER	1C	MedCom Header identification characteristics. Defined Terms: MEDCOM 1 (Required if MedCom Header Info (0029,xx10) present.)
MedCom Header Version	(0029,xx09)	SIEMENS MEDCOM HEADER	2C	Version of MedCom Header Info (0029,xx10) format. (Required if MEDCOM Header Info (0029,xx10) present.)
MedCom Header Info	(0029,xx10)	SIEMENS MEDCOM HEADER	3	Manufacturer model dependent information. The value of the attribute MedCom Header Info (0029,xx10) can be build up in each user defined format.
MedCom History Information	(0029,xx20)	SIEMENS MEDCOM HEADER	3	MedCom defined Patient Registration history information. See A.1.3.1.
PMTF Information 1	(0029,xx31)	SIEMENS MEDCOM HEADER	3	Transformation Information
PMTF Information 2	(0029,xx32)	SIEMENS MEDCOM HEADER	3	Transformation Information
PMTF Information 3	(0029,xx33)	SIEMENS MEDCOM HEADER	3	Transformation Information
PMTF Information 4	(0029,xx34)	SIEMENS MEDCOM HEADER	3	Transformation Information

### A.3 Private AXIOM.Artis Study Report (syngo Non-Image IOD)

The AXIOM Artis system will create numerical data that cannot be correlated to an individual image instance and therefore need to be stored in separate instance(s). This is necessary to correlate the information in the right level of the DICOM data model hierarchy. Since there is no fitting DICOM SOP Class definition, SIEMENS has created a private "Non-Image IOD" to contain numerical data heaps to be managed within a DICOM structure. Please see previous chapters of the Appendix for IOD definition and the following tables for detailed encoding of the different "Non-Image SOP Class Instances". Attached below is header dump of such an AXIOM.Artis Study Report:

*"overview of supplied attributes – Non-Image (Study Report)"*

Attribute Name	Tag	Value
Specific Character Set	(0008,0005)	from Configuration
Image Type	(0008,0008)	ORIGINAL\PRIMARY\SINGLE PLANE\STUDY REPORT
SOP Class UID	(0008,0016)	1.3.12.2.1107.5.9.1

Attribute Name	Tag	Value
SOP Instance UID	(0008,0018)	
Study Date	(0008,0020)	<yyyymmdd>
Series Date	(0008,0021)	<yyyymmdd>
Study Time	(0008,0030)	<hhmmss>
Series Time	(0008,0031)	<hhmmss>
Accession Number	(0008,0050)	RIS or "Accession Number" input
Modality	(0008,0060)	XA
Manufacturer	(0008,0070)	Siemens
Institution Name	(0008,0080)	
Performing Physician's Name	(0008,1050)	"Performing Physician 1" \ "Performing Physician 2" input
Admitting Diagnosis Description	(0018,1080)	RIS or "Admitting Diagnoses" input
Manufacturer's Model Name	(0008,1090)	AXIOM Artis
Patient's Name	(0010,0010)	RIS or "Patient Name" input
Patient ID	(0010,0020)	RIS or "Patient ID" input
Patient's Birth Date	(0010,0030)	RIS or checked input
Patient's Sex	(0010,0040)	RIS or input (M or F or O/unknown)
Patient's Age	(0010,1010)	calculated from "DoB" input
Patient's Size	(0010,1020)	(in meters)
Patient's Weight	(0010,1030)	(in kilograms)
Patient's Address	(0010,1040)	"Adress" input
Patient Comments	(0010,4000)	"Additional Info" input
Protocol Name	(0018,1030)	STUDY REPORT
Study Instance UID	(0020,000D)	from RIS or system generated
Series Instance UID	(0020,000E)	
Study ID	(0020,0010)	
Series Number	(0020,0011)	
Private Creator	(0029,00xx)	SIEMENS CSA NON-IMAGE
Data Type	(0029,xx08)	BSR REPORT
Data Version	(0029,xx09)	1.0
Requested Procedure Description	(0032,1060)	from RIS
Study Comments	(0032,4000)	"Exam Comment" input
Private Creator	(7FE1,00xx)	SIEMENS CSA NON-IMAGE
Data	(7FE1,xx10)	<Study Report data> (encoded as 8-Bit ASCII data, with <LF> as line separator)