

# SIEMENS

## FLUOROSPOT<sup>®</sup> T.O.P. VB15A

**AX**

### DICOM Conformance Statement

V1.5 16-June-00

© Siemens AG 2000  
All rights reserved

Siemens AG, Medical Engineering Group,  
Siemensstr. 1, D-91301 Forchheim, Germany

Headquarters: Berlin and Munich  
Siemens AG, Wittelsbacher Platz 2, D-80333 Munich, Germany

Manual Layout  
medigration GmbH, D-91058 Erlangen, Germany

Printed in the Federal Republic of Germany  
Release 06.00

## Table of Contents

<b>1</b>	<b>Introduction .....</b>	<b>5</b>
1.1	Overview .....	5
1.2	Scope and Field .....	5
1.3	Audience .....	5
1.4	Remarks .....	5
1.5	Definitions, Terms and Abbreviations .....	6
1.6	References .....	6
<b>2</b>	<b>Image Storage .....</b>	<b>7</b>
2.1	Implementation Model .....	7
2.1.1	Application Data Flow Diagram .....	7
2.1.2	Functional Definition "Image Send" .....	7
2.1.3	Sequencing of Real-World Activities .....	8
2.2	AE Specification .....	8
2.2.1	Association Establishment Policies .....	8
2.2.1.1	General .....	8
2.2.1.2	Number of Associations .....	8
2.2.1.3	Asynchronous Nature .....	8
2.2.1.4	Implementation Identifying Information .....	8
2.2.2	Association Initiation by Real-World Activity .....	9
2.2.2.1	Associated Real-World Activity .....	9
2.2.2.2	Proposed Presentation Context (Presentation Context Table) .....	9
2.2.2.3	SOP specific Conformance Statement .....	9
2.2.3	Association Acceptance Policy .....	10
2.3	Communication Profiles .....	10
2.3.1	Supported Communication Stacks (part 8) .....	10
2.3.2	TCP/IP Stack .....	10
2.3.3	Physical Media Support .....	10
2.4	Extensions / Specializations / Privatizations .....	10
2.4.1	Standard Extended / Specialized / Private SOPs .....	10
2.4.2	Private Transfer Syntaxes .....	10
2.5	Configuration .....	10
2.5.1	AE Title/Presentation Address Mapping .....	10
2.5.2	Configurable Parameters .....	10
2.5.2.1	Number of Simultaneous Associations .....	10
2.5.2.2	Maximum PDU Size (configurable in Service) .....	11
2.5.2.3	Time Out (configurable in Service) .....	11
2.6	Support of Extended Character Sets .....	11
<b>3</b>	<b>Worklist Management .....</b>	<b>12</b>
3.1	Implementation Model .....	12

3.1.1	Application Data Flow Diagram.....	12
3.1.2	Functional Definition "Worklist Update" .....	12
3.1.3	Sequencing of Real-World Activities.....	13
<b>3.2</b>	<b>AE Specification.....</b>	<b>13</b>
3.2.1	Association Establishment Policies.....	13
3.2.1.1	General.....	13
3.2.1.2	Number of Associations .....	13
3.2.1.3	Asynchronous Nature.....	13
3.2.1.4	Implementation Identifying Information .....	14
3.2.2	Association Initiation by Real-World Activity.....	14
3.2.2.1	Associated Real-World Activity .....	14
3.2.2.2	Proposed Presentation Context (Presentation Context Table) .....	14
3.2.2.3	SOP Specific Conformance Statement .....	14
3.2.3	Association Acceptance Policy .....	15
<b>3.3</b>	<b>Communication Profiles .....</b>	<b>15</b>
3.3.1	Supported Communication Stacks (part 8).....	15
3.3.2	TCP/IP Stack.....	15
3.3.3	Physical Media Support .....	15
<b>3.4</b>	<b>Extensions/Specializations/Privatizations .....</b>	<b>15</b>
3.4.1	Standard Extended Basic Worklist Management .....	15
3.4.2	Private Transfer Syntaxes.....	15
<b>3.5</b>	<b>Configuration .....</b>	<b>15</b>
3.5.1	AE Title/Presentation Address Mapping.....	15
3.5.2	Configurable Parameters .....	15
3.5.2.1	Number of Simultaneous Associations .....	16
3.5.2.2	Maximum PDU Size (configurable in Service) .....	16
3.5.2.3	Time Out (configurable in Service).....	16
<b>3.6</b>	<b>Support of Extended Character Sets .....</b>	<b>16</b>
<b>4</b>	<b>Verification .....</b>	<b>17</b>
<b>4.1</b>	<b>Implementation Model .....</b>	<b>17</b>
4.1.1	Application Data Flow Diagram.....	17
4.1.2	Functional Definition Verification.....	17
4.1.3	Sequencing of Real-World Activities.....	17
<b>4.2</b>	<b>AE Specification.....</b>	<b>17</b>
4.2.1	Association Establishment Policies.....	18
4.2.1.1	General.....	18
4.2.1.2	Number of Associations .....	18
4.2.1.3	Asynchronous Nature.....	18
4.2.1.4	Implementation Identifying Information .....	18
4.2.2	Association Initiation by Real-World Activity.....	19
4.2.2.1	Associated Real-World Activity .....	19
4.2.2.2	Proposed Presentation Context (Presentation Context Table) .....	19
4.2.2.3	SOP Specific Conformance Statement .....	19
4.2.3	Association Acceptance Policy .....	19
<b>4.3</b>	<b>Communication Profiles .....</b>	<b>19</b>
4.3.1	Supported Communication Stacks (part 8).....	19
4.3.2	TCP/IP Stack.....	20
4.3.3	Physical Media Support .....	20
<b>4.4</b>	<b>Extensions/Specializations/Privatizations .....</b>	<b>20</b>
4.4.1	Standard Extended Basic Worklist Management .....	20
4.4.2	Private Transfer Syntaxes.....	20
<b>4.5</b>	<b>Configuration .....</b>	<b>20</b>

4.5.1	AE Title/Presentation Address Mapping .....	20
4.5.2	Configurable Parameters .....	20
4.5.2.1	Number of Simultaneous Associations .....	20
4.5.2.2	Maximum PDU Size (configurable in Service) .....	21
4.5.2.3	Time Out (configurable in Service) .....	21
<b>4.6</b>	<b>Support of Extended Character Sets .....</b>	<b>21</b>
<b><i>Annex A: Siemens DICOM Storage Standard Extended IOD Description .....</i></b>		<b>22</b>
<b>Table A.1: Standard Secondary Capture Elements.....</b>		<b>22</b>
<b>Table A.2: Elements of the XRF IOD Supported in SC Images.....</b>		<b>23</b>
<b>Table A.3: Other Elements Supported .....</b>		<b>23</b>
<b>Table A.4: Retired Elements Supported.....</b>		<b>23</b>
<b>Table A.5: Private Elements, Displayed on the User Interface.....</b>		<b>24</b>
<b><i>Annex B: Siemens Worklist Request Identifier Description .....</i></b>		<b>25</b>
<b>Table B.1: Worklist Request Identifier .....</b>		<b>25</b>

## 1 Introduction

### 1.1 Overview

The Conformance Statement describes the DICOM interface for the Siemens FLUOROSPOT® T.O.P. VB15A in terms of part 2 of [DICOM].

This introduction describes the application's implemented DICOM functionality in general terms.

### 1.2 Scope and Field

The Siemens product FLUOROSPOT® T.O.P is a Multipurpose System for digital R/F, Angiography and Interventional Procedures. The FLUOROSPOT® T.O.P. is designed to be integrated into an environment of medical DICOM-based devices. FLUOROSPOT® T.O.P. supports the storage of images utilizing the DICOM "Storage Service Class" and the retrieval of worklists from an Information System utilizing the DICOM "Basic Worklist Management Service Class". For testing it is utilizing the DICOM "Verification Service Class"

### 1.3 Audience

This document is intended for hospital staff, health system integrators, software designers or implementers. It is assumed that the reader has a working understanding of DICOM.

### 1.4 Remarks

DICOM, by itself, does not guarantee interoperability. However, the Conformance Statement facilitates a first-level validation for interoperability between different applications supporting the same DICOM functionality as SCU and SCP, respectively.

This Conformance Statement is not intended to replace validation with other DICOM equipment to ensure proper exchange of information intended.

The scope of this Conformance Statement is to facilitate communication with Siemens and other vendors' Medical equipment. The Conformance Statement should be read and understood in conjunction with the DICOM 3.0 Standard [DICOM]. However, by itself it is not guaranteed to ensure the desired interoperability and a successful interconnectivity.

The user should be aware of the following important issues:

- The comparison of different conformance statements is the first step towards assessing interconnectivity between Siemens and non-Siemens equipment.
- Test procedures should be defined and tests should be performed by the user to validate the connectivity desired. DICOM itself and the conformance parts do not specify this.
- The standard will evolve to meet the users' future requirements. Siemens is actively involved in developing the standard further and therefore reserves the right to make changes to its products or to discontinue its delivery.

## 1.5 Definitions, Terms and Abbreviations

Definitions, terms and abbreviations used in this document are defined within the different parts of the DICOM standard.

Additional Abbreviations and terms are as follows:

CSE	Customer Service Engineer
DSA	Digital Subtraction Angiography
RIS	Radiology Information System
SIREGRAPH CF	Overtable System by SIEMENS
SIT	Siemens Installation Tool, configuration tool used by CSE
SUN OS	UNIX operating system from SUN Microsystems, Inc., Palo Alto, USA

## 1.6 References

[DICOM] Digital Imaging and Communications in Medicine (DICOM), NEMA PS 3.1-3.14, 1999

## 2 Image Storage

### 2.1 Implementation Model

#### 2.1.1 Application Data Flow Diagram

Image Send is performed on the user's request for each study completed or for specific images selected. Upon request, an association will be initiated, one of the images selected will be sent to the remote node and the association will be closed. This procedure will be repeated until all images selected are sent.

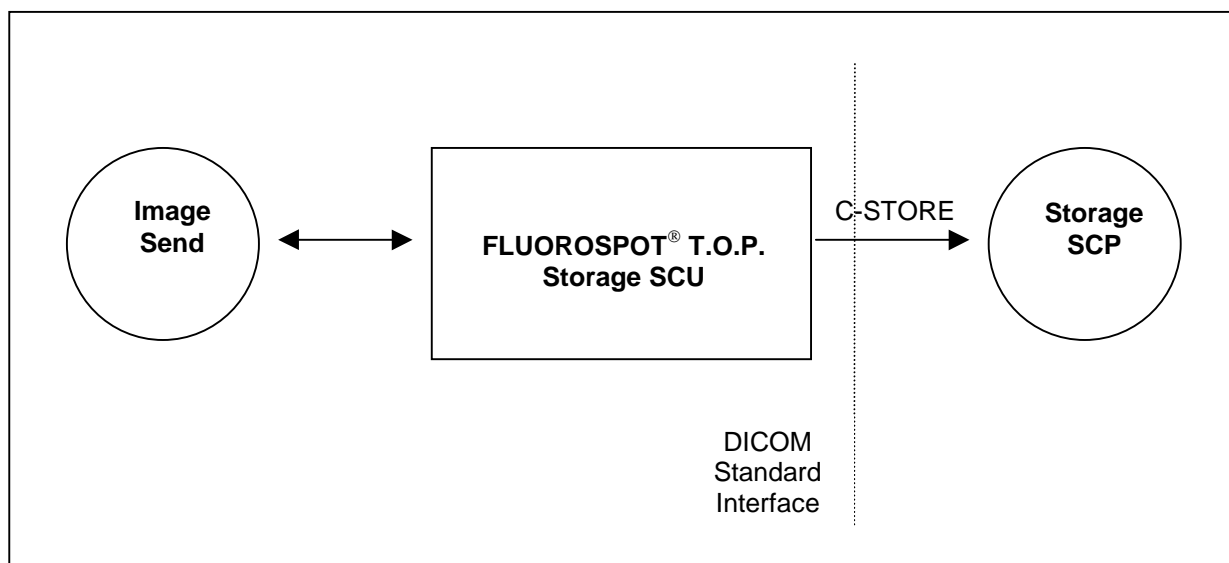

Figure 1: FLUOROSPOT® T.O.P. DICOM Storage Implementation Model

#### 2.1.2 Functional Definition "Image Send"

The FLUOROSPOT® T.O.P. DICOM Application Entity acts as a Service Class User (SCU) for the

- Storage Service Class (to store images in a remote DICOM Node)

Upon the completion of an imaging procedure the FLUOROSPOT® T.O.P. will build a DICOM standard extended SC IOD data set and initiates sequential associations for each image to be sent.

For more information regarding the DICOM standard extended data sets, please refer to Section 2.2.2.3 "SOP specific Conformance Statement" and Annex A.

The Image Send Functionality is initiated through the user interface. The remote destination has to be defined during the configuration procedure.

If any other SCP response status than "Success" or "Warning" is received by FLUOROSPOT® T.O.P., a notification to check for network problems will appear on the user interface.

During the transmission of images to the remote node, a yellow "busy-light" will be displayed. After completion the light turns off automatically.

### 2.1.3 Sequencing of Real-World Activities

not applicable

## 2.2 AE Specification

The FLUOROSPOT® T.O.P. Application Entity provides Standard Conformance to the following DICOM SOP Class as a SCU:

SOP Class Name	SOP Class UID
Secondary Capture Image Storage	1.2.840.10008.5.1.4.1.1.7

### 2.2.1 Association Establishment Policies

#### 2.2.1.1 General

Application Context Name (ACN)	1.2.840.10008.3.1.1.1
Maximum Length PDU offered	configurable in Service, default 28 KB

#### 2.2.1.2 Number of Associations

FLUOROSPOT® T.O.P. will attempt to initiate one association at a time, one for each Image to be sent.

#### 2.2.1.3 Asynchronous Nature

Asynchronous communication, i.e. multiple outstanding transactions over a single association, is not supported.

#### 2.2.1.4 Implementation Identifying Information

Implementation Class UID	1.3.12.2.1107.5.3.3.1
--------------------------	-----------------------

Implementation Version Name	"SIEMENS_FLT_ST"
-----------------------------	------------------

**2.2.2 Association Initiation by Real-World Activity**

FLUOROSPOT® T.O.P. will attempt to initiate a new association for:

- DICOM Image Send (C-STORE)

**2.2.2.1 Associated Real-World Activity**

Image Send attempts to send an Image Object to a remote node. If the FLUOROSPOT® T.O.P. AE establishes an association to a remote AE, it will transfer one image at a time via the open association. If the C-STORE response from the remote node contains a status other than "Success" or "Warning", the association is aborted. The image remains on the FLUOROSPOT® T.O.P. with the status "Aborted". Image Send can be restarted at any time by user interaction.

The DICOM target nodes will be configured by a CSE with the SIT service tool. For each node it is configurable, whether the SC IOD or the modality specific (XRF or XA) IOD is used.

**2.2.2.2 Proposed Presentation Context (Presentation Context Table)**

The DICOM Interface of the FLUOROSPOT® T.O.P. will propose the following presentation contexts:

Presentation Context Table					
Abstract Syntax		Transfer Syntax		Role	Extended Negotiation
Name	UID	Name List	UID List		
Secondary Captured Image Storage Service Class	1.2.840.10008.5.1.4.1.1.7	DICOM Implicit VR Little Endian	1.2.840.10008.1.2	SCU	None

**2.2.2.3 SOP specific Conformance Statement**

The DICOM images created by the DICOM interface of the FLUOROSPOT® T.O.P. conform to the DICOM IOD definitions (Standard extended IODs). The objects contain additional elements, so-called "retired" elements from earlier versions of the standard. Please refer to Annex A for a complete listing of all supported DICOM elements.

The receiving DICOM nodes are responsible for data consistency when modifying images. All unknown private data elements have to be removed upon modification.

### 2.2.3 Association Acceptance Policy

not applicable

## 2.3 Communication Profiles

### 2.3.1 Supported Communication Stacks (part 8)

The DICOM Interface of the FLUOROSPOT® T.O.P. provides DICOM TCP/IP Network Communication Support as defined in Part 8 of the DICOM Standard.

### 2.3.2 TCP/IP Stack

The DICOM Interface of the FLUOROSPOT® T.O.P. uses the TCP/IP stack from the SUN-OS Solaris 2.x system upon which it executes. It uses a subroutine library, based on a Berkeley socket interface.

### 2.3.3 Physical Media Support

The DICOM Interface of the FLUOROSPOT® T.O.P. is indifferent to the physical medium over which TCP/IP executes. It inherits this from the SUN-OS UNIX System upon which it executes.

## 2.4 Extensions / Specializations / Privatizations

### 2.4.1 Standard Extended / Specialized / Private SOPs

For extended IODs see Appendix A

### 2.4.2 Private Transfer Syntaxes

None

## 2.5 Configuration

### 2.5.1 AE Title/Presentation Address Mapping

The Application Entity Title, Host name and Port number are defined via the SIT service tool. The SIT service tool is intended to be used by a CSE only.

### 2.5.2 Configurable Parameters

The Application Entity Titles, Host names and Port numbers are configured using the SIT.

Maximum PDU Size and time outs are configured using the SIT.

The tag Modality (0008,0060) is configurable in the system configuration. Default is "RF".

#### 2.5.2.1 Number of Simultaneous Associations

FLUOROSPOT® T.O.P. supports for one service only one association at a time.

**2.5.2.2 Maximum PDU Size (configurable in Service)**

- max PDU size: default 28 KB

**2.5.2.3 Time Out (configurable in Service)**

- time-out until a SCP has to accept/reject an association request: default 30 sec
- time-out for accepting a message over network: default 15 sec
- time-out for waiting for data between packets: default 15 sec

**2.6 Support of Extended Character Sets**

ISO-IR 100 (ISO 8859-1:1987 Latin Alphabet N 1. supplementary set)

### 3 Worklist Management

#### 3.1 Implementation Model

##### 3.1.1 Application Data Flow Diagram

Worklist Update is performed as a result of an operator request, or automatically at certain time intervals. Each request results in an initiation for an association. Under normal conditions the association will be closed after receiving a "Success" response from the Information System.

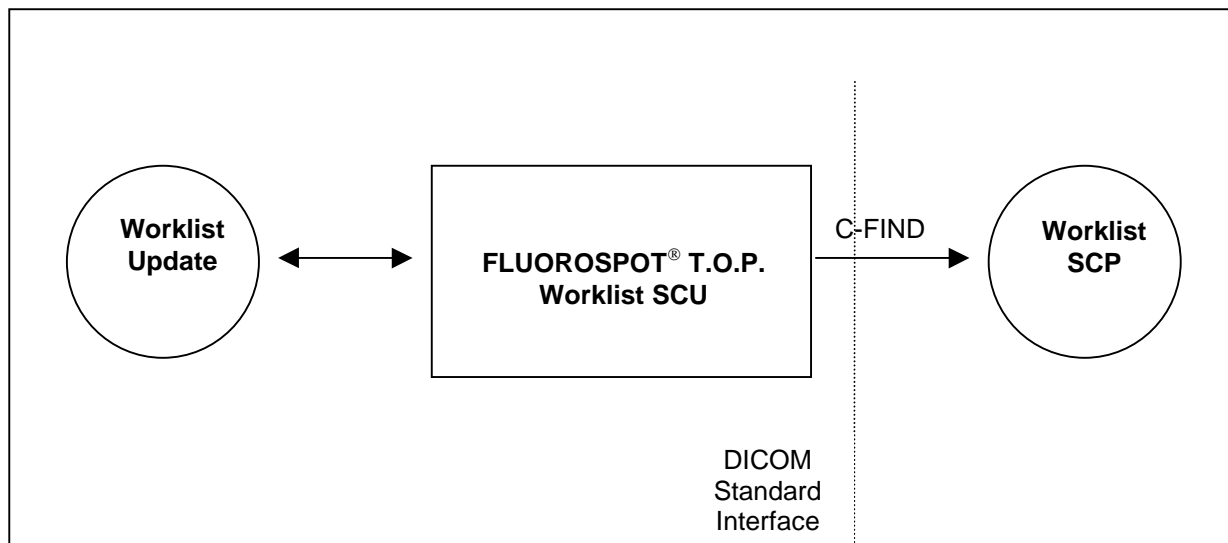

Figure 2: FLUOROSPOT® T.O.P. DICOM Worklist Implementation Model

##### 3.1.2 Functional Definition "Worklist Update"

The FLUOROSPOT® T.O.P. DICOM Application Entity acts as a Service Class User (SCU) for the

- Basic Worklist Management Service Class (to request a Worklist from a RIS)

The request for a Worklist Update is initiated by user interaction, i.e. pressing the button "Update", or automatically at certain time intervals. These intervals are configurable, from one to 60 minutes.

Upon initiation of the request, the FLUOROSPOT® T.O.P. will build an Identifier for the C-FIND request, will initiate an association to send the request and will wait for Worklist responses. After retrieval of all responses, FLUOROSPOT® T.O.P. will access the local data base to add or update patient demographic data.

FLUOROSPOT® T.O.P. requests all items for a specific day (actual date) scheduled for this modality (DF or RF, to be configured) or scheduled for the station (AET). The choice is configurable within the SIT service tool (CSE only).

If any other SCP response status than "Success" or "Pending" is received by FLUOROSPOT® T.O.P., a notification to check for network problems will appear on the user interface.

The FLUOROSPOT® T.O.P. Worklist Request Identifier is described in Annex B "Siemens Worklist Request Identifier Description".

### 3.1.3 Sequencing of Real-World Activities

not applicable

## 3.2 AE Specification

The FLUOROSPOT® T.O.P. Application Entity provides Standard Conformance to the following DICOM SOP Class as a SCU:

SOP Class Name	SOP Class UID
Modality Worklist Information Model - FIND	1.2.840.10008.5.1.4.31

### 3.2.1 Association Establishment Policies

#### 3.2.1.1 General

Application Context Name (ACN)	1.2.840.10008.3.1.1.1
Maximum Length PDU offered	configurable in Service, default 28 KB

#### 3.2.1.2 Number of Associations

FLUOROSPOT® T.O.P. will attempt to initiate one association for a Worklist Update request.

#### 3.2.1.3 Asynchronous Nature

Asynchronous communication, i.e. multiple outstanding transactions over a single association, is not supported.

### 3.2.1.4 Implementation Identifying Information

Implementation Class UID	1.3.12.2.1107.5.3.3.2
Implementation Version Name	"SIEMENS_FLT_WL"

### 3.2.2 Association Initiation by Real-World Activity

FLUOROSPOT® T.O.P. will attempt to initiate a new association for:

- DICOM Worklist Update (C-FIND)

#### 3.2.2.1 Associated Real-World Activity

Worklist Update attempts to download a Worklist from a remote node. If the FLUOROSPOT® T.O.P. AE establishes an association to a remote AE, it will transfer all worklist items via the open association.

If the C-FIND responses from the remote node contain a status other than "Success" or "Pending", the association is aborted. The next attempt to establish an association will take place automatically after the configured time interval for Worklist Update (one to 60 minutes), or at the user's request by pressing the Update button.

#### 3.2.2.2 Proposed Presentation Context (Presentation Context Table)

The DICOM Interface of the FLUOROSPOT® T.O.P. will propose the following presentation contexts:

Presentation Context Table					
Abstract Syntax		Transfer Syntax		Role	Extended Negotiation
Name	UID	Name List	UID List		
Modality Worklist Information Model FIND	1.2.840.10008.5.1.4.31	DICOM Implicit VR Little Endian	1.2.840.10008.1.2	SCU	None
		DICOM Explicit VR Little Endian	1.2.840.10008.1.2.1	SCU	None
		DICOM Explicit VR Big Endian	1.2.840.10008.1.2.2	SCU	None

#### 3.2.2.3 SOP Specific Conformance Statement

Please refer to Annex B for the description of the Siemens Worklist Request Identifier.

### 3.2.3 Association Acceptance Policy

not applicable

## 3.3 Communication Profiles

### 3.3.1 Supported Communication Stacks (part 8)

The DICOM Interface of the FLUOROSPOT® T.O.P. provides DICOM TCP/IP Network Communication Support as defined in Part 8 of the DICOM Standard.

### 3.3.2 TCP/IP Stack

The DICOM Interface of the FLUOROSPOT® T.O.P. uses the TCP/IP stack from the SUN-OS Solaris 2.x system upon which it executes. It uses a subroutine library, based on a Berkeley socket interface.

### 3.3.3 Physical Media Support

The DICOM Interface of the FLUOROSPOT® T.O.P. is indifferent to the physical medium over which TCP/IP executes. It inherits this from the SUN-OS UNIX System upon which it executes.

## 3.4 Extensions/Specializations/Privatizations

### 3.4.1 Standard Extended Basic Worklist Management

Please refer to Annex B for the description of the Siemens Worklist Request Identifier.

### 3.4.2 Private Transfer Syntaxes

None

## 3.5 Configuration

### 3.5.1 AE Title/Presentation Address Mapping

The Application Entity Title, Host name and Port number are defined via the SIT service tool. The SIT service tool is intended to be used by a CSE only.

### 3.5.2 Configurable Parameters

The Application Entity Titles, Host names and Port numbers are configured using the SIT.

Maximum PDU Size and time outs are configured using the SIT.

Within the SIT is configurable, if all data for the given modality or only the data for the specific AET is received.

The tag Modality (0008,0060) for the worklist query is configurable in the system configuration. Default is "RF"

### 3.5.2.1 Number of Simultaneous Associations

FLUOROSPOT® T.O.P. supports for one service only one association at a time.

### 3.5.2.2 Maximum PDU Size (configurable in Service)

- max PDU size: default 28 KB

### 3.5.2.3 Time Out (configurable in Service)

- time-out until a SCP has to accept/reject an association request: default 30 sec
- time-out for accepting a message over network: default 15 sec
- time-out for waiting for data between packets: default 15 sec

## 3.6 Support of Extended Character Sets

ISO-IR 100 (ISO 8859-1:1987 Latin Alphabet N 1. supplementary set)

**4 Verification**

**4.1 Implementation Model**

**4.1.1 Application Data Flow Diagram**

Verification is performed by a CSE to verify the ability of a foreign DICOM application on a remote node to respond to DICOM messages.

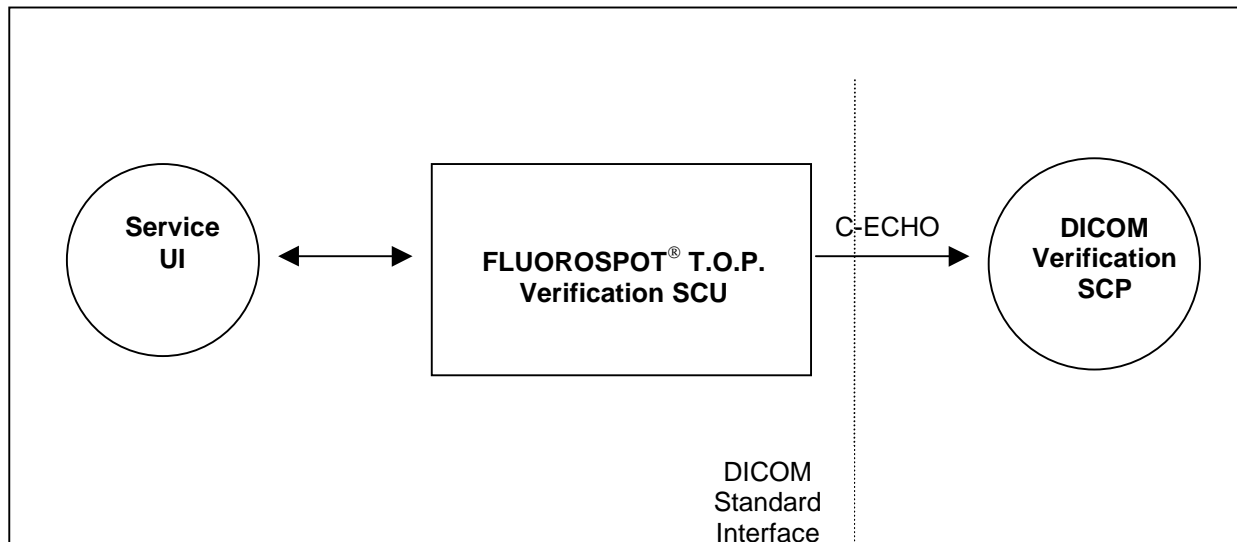

Figure 4: FLUOROSPOT® T.O.P. DICOM Verification Implementation Model

**4.1.2 Functional Definition Verification**

The Service UI Tool opens an association when a test of a remote application is requested during a configuration session. This can be done after adding or change a remote node in the configuration to verify the communication.

**4.1.3 Sequencing of Real-World Activities**

not applicable

**4.2 AE Specification**

The FLUOROSPOT® T.O.P. Application Entity provides Standard Conformance to the following DICOM SOP Class as a SCU:

SOP Class Name	SOP Class UID
Verification	1.2.840.10008.1.1

## 4.2.1 Association Establishment Policies

### 4.2.1.1 General

Application Context Name (ACN)	1.2.840.10008.3.1.1.1
Maximum Length PDU offered to a Storage SCP	configurable in Service, default 28 KB
Maximum Length PDU offered to a Worklist SCP	configurable in Service, default 28 KB

### 4.2.1.2 Number of Associations

FLUOROSPOT® T.O.P. will attempt to initiate one association for verification.

### 4.2.1.3 Asynchronous Nature

Asynchronous communication, i.e. multiple outstanding transactions over a single association, is not supported.

### 4.2.1.4 Implementation Identifying Information

Implementation Class UID	Same as tested service
Implementation Version Name	Same as tested service

## 4.2.2 Association Initiation by Real-World Activity

FLUOROSPOT® T.O.P. will attempt to initiate a new association for:

- DICOM Verification (C-ECHO)

### 4.2.2.1 Associated Real-World Activity

The associated Real-World Activity is C-ECHO request initiated by the CSE to check whether a remote node is correctly configured. Any response other than "Success" implies an error in configuration either at the local or at the remote node.

### 4.2.2.2 Proposed Presentation Context (Presentation Context Table)

The DICOM Interface of the FLUOROSPOT® T.O.P. will propose the following presentation contexts:

Presentation Context Table					
Abstract Syntax		Transfer Syntax		Role	Extended Negotiation
Name	UID	Name List	UID List		
Verification	1.2.840.10008.1.1	DICOM Implicit VR Little Endian	1.2.840.10008.1.2	SCU	None
		DICOM Explicit VR Little Endian	1.2.840.10008.1.2.1	SCU	None
		DICOM Explicit VR Big Endian (not for Storage)	1.2.840.10008.1.2.2	SCU	None

### 4.2.2.3 SOP Specific Conformance Statement

DICOM Explicit VR Big Endian is not used for testing a Storage SCP

## 4.2.3 Association Acceptance Policy

not applicable

## 4.3 Communication Profiles

### 4.3.1 Supported Communication Stacks (part 8)

The DICOM Interface of the FLUOROSPOT® T.O.P. provides DICOM TCP/IP Network Communication Support as defined in Part 8 of the DICOM Standard.

### **4.3.2 TCP/IP Stack**

The DICOM Interface of the FLUOROSPOT® T.O.P. uses the TCP/IP stack from the SUN-OS Solaris 2.x system upon which it executes. It uses a subroutine library, based on a Berkeley socket interface.

### **4.3.3 Physical Media Support**

The DICOM Interface of the FLUOROSPOT® T.O.P. is indifferent to the physical medium over which TCP/IP executes. It inherits this from the SUN-OS UNIX System upon which it executes.

## **4.4 Extensions/Specializations/Privatizations**

### **4.4.1 Standard Extended Basic Worklist Management**

None

### **4.4.2 Private Transfer Syntaxes**

None

## **4.5 Configuration**

### **4.5.1 AE Title/Presentation Address Mapping**

The Application Entity Title, Host name and Port number are defined via the SIT service tool. The SIT service tool is intended to be used by a CSE only.

### **4.5.2 Configurable Parameters**

The Application Entity Titles, Host names and Port numbers are configured using the SIT.

Maximum PDU Size and time outs depend on the service to be tested. For each service they are configured using the SIT.

#### **4.5.2.1 Number of Simultaneous Associations**

FLUOROSPOT® T.O.P. supports for one service only one association at a time.

#### 4.5.2.2 Maximum PDU Size (configurable in Service)

- max PDU size (testing a Storage SCP): default 28 KB
- max PDU size (testing a Worklist SCP): default 28 KB
- max PDU size (testing a Print SCP): default 28 KB

#### 4.5.2.3 Time Out (configurable in Service)

- time-out until a SCP has to accept/reject an association request: default 30 sec
- time-out for accepting a message over network: default 15 sec
- time-out for waiting for data between packets: default 15 sec

#### 4.6 Support of Extended Character Sets

ISO-IR 100 (ISO 8859-1:1987 Latin Alphabet N 1. supplementary set)

## Annex A: Siemens DICOM Storage Standard Extended IOD Description

### Table A.1: Standard Secondary Capture Elements

Module	Attribute Name	TAG	Type	Comments	Visibility
Patient	Patient's Name	0010,0010	2	RIS or User Input	Patient List, New Patient, Image View, Film
	Patient ID	0010,0020	2	RIS or user input	Patient List, New Patient, Image View, Film
	Patient's Birth Date	0010,0030	2	RIS or user input	Patient List, New Patient, Image View, Film
	Patient's Sex	0010,0040	2	RIS or user input	New Patient
General Study	Study Instance UID	0020,000D	1	RIS or system generated	
	Study Date	0008,0020	2		Patient List
	Study Time	0008,0030	2		Patient List
	Referring Physician's Name	0008,0090	2	RIS	
	Study ID	0020,0010	2	System generated	
	Accession Number	0008,0050	2	RIS or User Input	Patient List*, New Patient, Film*
Patient Study	Admitting Diagnosis Description	0008,1080	3	RIS	
General Series	Modality	0008,0060	1	Configurable, default: "RF"	
	Series Instance UID	0020,000E	1		
	Series Number	0020,0011	2		
	Laterality	0020,0060	2C	always zero length	
	Performing Physician's Name	0008,1050	3	User input	Patient List, New Patient, Film
General Equipment	Manufacturer	0008,0070	2	"SIEMENS "	
	Institution Name	0008,0080	3	User input	Film
	Station Name	0008,1010	3	Service input (PLA)	
	Institutional Department Name	0008,1040	3	Same as 0008,0080	
	Manufacturer's Model Name	0008,1090	3	"FLUOROSPOT_TOP01"	Film
	Device Serial Number	0018,1000	3	Host ID	
	Software Versions	0018,1020	3		
SC Equipment	Conversion Type	0008,0064	1	Defined Term "DI" is used	
	Modality	0008,0060	3	See "General Series"	
General Image	Image Number	0020,0013	2		
	Patient Orientation	0020,0020	2C	always zero length	
	Image Date	0008,0023	2C		Image View, Film
	Image Time	0008,0033	2C		Image View, Film
	Image Type	0008,0008	3		
	Acquisition Number	0020,0012	3	Same as 0020,0013	
	Acquisition Date	0008,0022	3	Same as 0008,0023	
	Acquisition Time	0008,0032	3	Same as 0008,0033	
	Image Comments	0020,4000	3	User input	Image View, Film
	Image Pixel	Samples per Pixel	0028,0002	1	Always "1"
Photometric Interpretation		0028,0004	1	"MONOCHROME2"	
Rows		0028,0010	1	1024 or 2048	Image View, Film
Columns		0028,0011	1	1024 or 2048	Image View, Film
Bits Allocated		0028,0100	1	16	
Bits Stored		0028,0101	1	12	
High Bit		0028,0102	1	11	
Pixel Representation		0028,0103	1	0	
Pixel Data		7FE0,0010	1		
Overlay Plane		Overlay Rows	6000,0010	1	Same as 0028,0010
	Overlay Columns	6000,0011	1	Same as 0028,0011	
	Overlay Type	6000,0040	1	"G "	
	Origin	6000,0050	1	1,1	
	Overlay Bits Allocated	6000,0100	1	16	
	Bit Position	6000,0102	1	15	
VOI LUT	Window Center	0028,1050	3	-1024 .. 5120	
	Window Width	0028,1051	1C	8 .. 4096	
SOP Common	SOP Class UID	0008,0016	1		
	SOP Instance UID	0008,0018	1		
	Specific Character Set	0008,0005	1C	"ISO_IR 100"	

\* It is configurable by the user if Accession No., Requested Procedure ID or Organ (Requested Procedure Description), respectively, are shown in the Patient List and on Film.

**Table A.2: Elements of the XRF IOD Supported in SC Images**

Module	Attribute Name	Tag	Type	Comments	Visibility
Cine	Cine Rate	0018,0040	3	(0.5 is rounded to 1)	Image Report
X-Ray Image	Pixel Intensity Relationship	0028,1040	1	"LIN "	
	Scan Options	0018,0022	3	Only with tomo and peri images	
X-Ray Acquisition	KVP	0018,0060	2		Image Report
	Radiation Setting	0018,1155	1		
	Exposure Time	0018,1150	2C		
	Exposure	0018,1152	2C	Rounded to integer	Image Report
	Grid	0018,1166	3		
	Average Pulse Width	0018,1154	3		Image Report
	Radiation Mode	0018,115A	3		
	Intensifier Size	0018,1162	3		
	Field of View Shape	0018,1147	3	"ROUND "	
	Field of View Dimension(s)	0018,1149	3		Image Report
X-Ray Table	Table Motion	0018,1134	3	"STATIC"	
XRF Positioner	Distance Source to Patient	0018,1111	3	not with SIREGRAPH CF	
	Distance Source to Detector	0018,1110	3	not with SIREGRAPH CF	
XRF Tomo Acquisition	Tomo Layer Height	0018,1460	1	Only with Tomo Images; not with SIREGRAPH CF	Image View, Film
	Tomo Time	0018,1480	3	Only with Tomo Images; not with SIREGRAPH CF	

**Table A.3: Other Elements Supported**

Module	Attribute	Tag	Type	Comments	Visibility
Patient Medical	Medical Alerts	0010,2000		RIS	
	Contrast Allergies	0010,2110		RIS	
	Pregnancy Status	0010,21C0		RIS	
Image Plane	Pixel Spacing	0028,0030		Used for distance measurement	
Requested Procedure	Requested Procedure Description	0032,1060		RIS or user input ("Organ")	Patient List*, New Patient, Film*
Visit Status	Current Patient Location	0038,0300		RIS or user input	Patient List, New Patient, Film
Requested Procedure	Requested Procedure ID	0040,1001		RIS or user input	Patient List*, New Patient, Film*

\* It is configurable by the user if Accession No., Requested Procedure ID or Organ (Requested Procedure Description), respectively, are shown in the Patient List and on Film.

**Table A.4: Retired Elements Supported**

Module	Attribute Name	Tag	Type	Comments	Visibility
	DATA Set Type	0008,0040	RET	0	
	DATA Set Subtype	0008,0041	RET	"IMA DFR " or "IMA TOMO"	
	Comments	0018,4000	RET	Same as 0020,4000	

**Table A.5: Private Elements, Displayed on the User Interface**

<b>Attribute</b>	<b>Private Creator</b>	<b>Tag</b>	<b>Comments</b>	<b>Visibility</b>
Edge Enhancement [%] ("E:")	SIEMENS DFR.01 MANIPULATED	0017,xx29	[0..100]	Image View, Film
Harmonization [%] ("H:")	SIEMENS DFR.01 MANIPULATED	0017,xx30	[0..100]	Image View, Film
Landmark	SIEMENS DFR.01 MANIPULATED	0017,xx71	[0..100]	Image View, Film
Pixel Shift horizontal	SIEMENS DFR.01 MANIPULATED	0017,xx77	[-20.0 .. +20.0]	Image View, Film
Pixel Shift vertical	SIEMENS DFR.01 MANIPULATED	0017,xx78	[-20.0 .. +20.0]	Image View, Film
Left Marker	SIEMENS DFR.01 MANIPULATED	0017,xx83	Text, i.e. "L"	Image View, Film
Right Marker	SIEMENS DFR.01 MANIPULATED	0017,xx84	Text, i.e. "R"	Image View, Film
Image Name Extension 1	SIEMENS DFR.01 MANIPULATED	0017,xxA2	Image Number 1 <sup>st</sup> line	Image View, Film
Image Name Extension 2	SIEMENS DFR.01 MANIPULATED	0017,xxA3	Image Number 2 <sup>nd</sup> line	Image View, Film

## Annex B: Siemens Worklist Request Identifier Description

**Table B.1: Worklist Request Identifier**

Module Name Attribute Name	Matching Key Type	Return Key Type	Tag	M	R	DICOM Part 3 Tables
<b>Scheduled Procedure Step</b> Scheduled Procedure Step Sequence > Modality > Scheduled Station AETitle > Scheduled Procedure Step Start Date	R R R R	1 1 1 1	0040,0100 0008,0060 0040,0001 0040,0002		F F R	C.4-10
<b>Requested Procedure</b> Requested Procedure ID Requested Procedure Description Study Instance UID	O O O	1 1C 1	0040,1001 0032,1060 0020,000D		x x x	C.4-11
<b>Imaging Service Request</b> Accession Number Referring Physician's Name	O O	2 2	0008,0050 0008,0090		x x	C.4-12
<b>Visit Status</b> Current Patient Location	O	2	0038,0300		x	C.3-3
<b>Visit Admission</b> Admitting Diagnosis Description	O	3	0008,1080		x	C.3-4
<b>Patient Identification</b> Patient Name Patient ID	R R	1 1	0010,0010 0010,0020	*	x x	C.2-2
<b>Patient Demographic</b> Patient's Birth Date Patient's Sex	O O	2 2	0010,0030 0010,0040		x x	C.2-3
<b>Patient Medical</b> Medical Alerts Contrast Allergies Pregnancy Status	O O O	2 2 2	0010,2000 0010,2110 0010,21C0		x x x	C.2-4

### Matching Types

M: Matching Key

F: Fixed Single Value (Value configured by CSE)

R: Range matching for start date only (always for actual date, i.e. 19980811-19980811 )

S: Single Value matching

W: Wildcard matching

R: Return Keys

x: Universal Matching

The Information Model Module Table defines the fixed structure of the Worklist Request Identifier.

The table should be read as follows:

- First column: Module Name and attributes supported to build a FLUOROSPOT® T.O.P. Worklist Request Identifier.
- Second column: Requested [R] or optional [O] Matching key. FLUOROSPOT® T.O.P. assumes that the Modality Worklist SCP supports Matching Keys as defined in DICOM PS 3.4 K.2.2.1.1, i.e. that a SCP is able to at least perform Fixed Single Value, Wildcard and Date Range matching.
- Third column: Mandatory, conditional and optional Return key.
- Fourth column: Appropriate DICOM tag for this attribute.
- Next two columns: FLUOROSPOT® T.O.P. only expects a "Fixed Value Matching" for "Modality" or Scheduled Station AETitle, respectively, "Range Matching" for "Scheduled

Procedure Step Start Date" and Wildcard Matching for Patient Name. All other attribute are defined as Return Keys only.

- Last column: Reference to the DICOM standard