

syngo CT 2012E

DICOM Conformance Statement

www.siemens.com/healthcare

SIEMENS



This product is provided with a CE mark in accordance with the regulations stated in Council Directive 93/42/EEC of June 14th, 1993, concerning Medical Devices.

The CE marking applies only to Medical Devices which have been put on the market according to the above-mentioned EC Directive. Unauthorized changes to this product are not covered by the CE mark and the related Declaration of Conformity.

The original language of this document is English.



Table of Contents

Introduction

A DICOM Conformance Statement Network

- A.1 Implementation Models
- A.2 AE Specifications
- A.3 Communication Profiles
- A.4 Extensions/Specializations/Privatizations
- A.5 Configuration
- A.6 Support of Extended Character Sets

B DICOM Conformance Statement Media Storage

- B.1 Implementation Model
- B.2 Application Entity Specifications
- B.3 Augmented and Private Profiles
- B.4 Extensions, Specializations and Privatizations of SOP Classes and Transfer Syntaxes
- B.5 Configuration
- B.6 Support of Extended Character Sets

Appendix



Introduction

Overview

This DICOM Conformance Statement is written according to part PS 3.2 of [1].

The applications described in this conformance statement are implemented in the Siemens SOMATOM products using software Somaris/5 *syngo* CT 2012E (internal: VB41A).

The Somaris/5 DICOM network implementation acts as SCU and SCP for the DICOM Verification, Storage, Storage Commitment Push Model, and Query/Retrieve Services. It acts as SCU for the DICOM Print Management Service, the Modality Worklist Service, and the Performed Procedure Step Service.

These services are described in "Part I".

The Somaris/5 DICOM Media Storage Service implementation acts as FSC, FSU, and FSR for the specified application profiles and the related SOP Class instances. These services are described in "Part II".

Somaris/5 is based on a Siemens common medical platform. This platform is shared with other Siemens modalities in order to provide a common look and feel and common interoperability features.

In this document parts of the Siemens common medical platform are referenced by the terms "*syngo*"^{®1}, "MedCom", and "CSA".

As Somaris/5 is a *syngo* based product, this DICOM Conformance Statement is based on the corresponding *syngo* template [2].

1. '*syngo*' and '*We speak syngo*' are registered trademarks of Siemens AG

Audience

This document is intended for hospital staff, health system integrators, hospital IT-managers, and software designers or implementors. It is assumed that the reader has a working understanding of DICOM.

Scope

This DICOM Conformance Statement refers to Siemens SOMATOM products using software Somaris/5. The following table relates software names to Siemens products.

Siemens Product	Software Name	Internal
Sensation Open	Somaris/5 <i>syngo</i> CT 2012E	VB41A
Sensation 40	Somaris/5 <i>syngo</i> CT 2012E	VB41A
Sensation 64	Somaris/5 <i>syngo</i> CT 2012E	VB41A
Sensation Cardiac 64	Somaris/5 <i>syngo</i> CT 2012E	VB41A
Emotion 6-slice configuration	Somaris/5 <i>syngo</i> CT 2012E	VB41A
Emotion 16-slice configuration	Somaris/5 <i>syngo</i> CT 2012E	VB41A

Definitions

- ❑ **DICOM**: Digital Imaging and Communications in Medicine
- ❑ **DIMSE**: DICOM Message Service Element
- ❑ **DIMSE-C**: DICOM Message Service Element with Composite information objects

Acronyms and Abbreviations

- ❑ **ACR**: American College of Radiology
- ❑ **AE**: DICOM Application Entity
- ❑ **ASCII**: American Standard Code for Information Interchange
- ❑ **FSC**: File Set Creator
- ❑ **FSR**: File Set Reader
- ❑ **FSU**: File Set Updater
- ❑ **HIS**: Hospital Information System
- ❑ **IOD**: DICOM Information Object Definition
- ❑ **ISO**: International Standard Organization
- ❑ **NEMA**: National Electrical Manufacturers Association
- ❑ **O**: Optional Key Attribute
- ❑ **R**: Required Key Attribute
- ❑ **RIS**: Radiology Information System
- ❑ **RWA**: Real-World Activity
- ❑ **PDU**: DICOM Protocol Data Unit
- ❑ **SCU**: DICOM Service Class User (DICOM client)
- ❑ **SCP**: DICOM Service Class Provider (DICOM server)
- ❑ **SOP**: DICOM Service-Object Pair
- ❑ **U**: Unique Key Attribute
- ❑ **UID**: Unique Identifier
- ❑ **VR**: Value Representation

References

[1]: Digital Imaging and Communications in Medicine (DICOM) 3.0, NEMA PS 3.1-3.14

DICOM Standard is under continuous maintenance, the current official version is available at: <http://dicom.nema.org>

[2]: *syngo* VE32B DICOM Conformance Statement

Connectivity and Interoperability

The implementation of the Somaris/5 DICOM interface has been carefully tested to assure correspondence with this Conformance Statement. But the Conformance Statement and the DICOM standard do not guarantee interoperability of Siemens modalities and modalities of other vendors. The user must compare the relevant Conformance Statements and if a successful interconnection should be possible, the user is responsible to specify an appropriate test suite and to validate the interoperability, which is required. A network environment may need additional functions out of the scope of DICOM.

PART
A

DICOM Conformance Statement

Network



Verification

The Verification service class defines an application-level class of service which allows for the operator to verify the ability of an application on a remote node to respond to DICOM messages. The DICOM Service Tool application supports the Verification service to act as SCU.

The other direction – responding to Verification requests from remote applications – is handled by the Storage SCP application.

Application Data Flow Diagram

The Somaris/5 DICOM network implementation acts as SCU for the C-ECHO DICOM network service. The product target operating system is Windows XP.

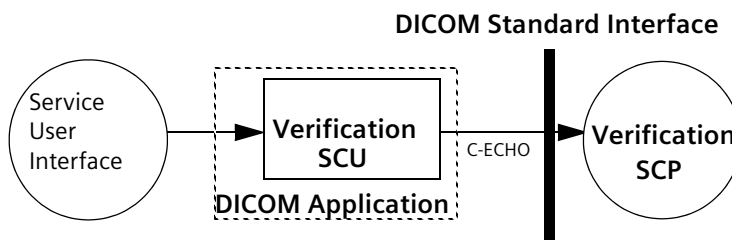

Functional Definitions of Application Entities

The DICOM Service Tool application opens an association to an application on the remote node and sends a Verification message to verify that the remote application can respond to DICOM messages.

Sequencing of Real-World Activities

Newly configured data of a remote AE have to be saved first, before a "verification" of these data is possible.

Storage

The Somaris/5 DICOM Application Entity both originates associations for Storage of DICOM Composite Information Objects in Remote Application Entities and accepts association requests for Storage from Remote Application Entities.

Application Data Flow Diagram

The Somaris/5 DICOM network implementation acts as SCU and SCP for the C-STORE DICOM network service and as SCP for the C-ECHO DICOM network service. The product target operating system is Windows XP.

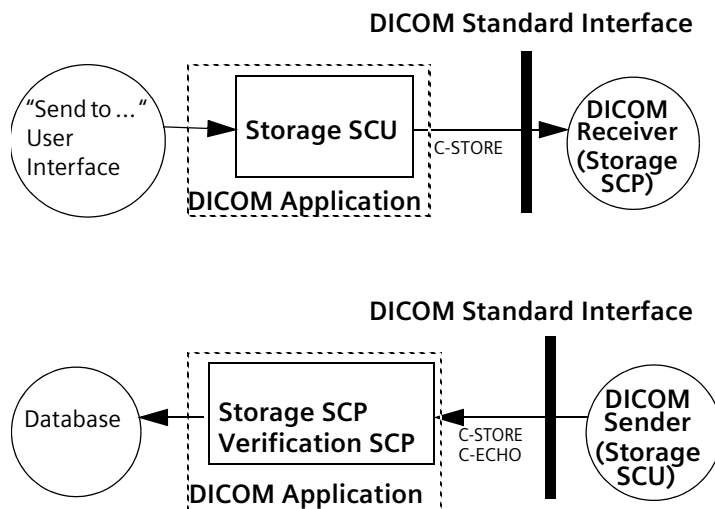

Functional Definitions of Application Entities

The Storage SCU is invoked by the job control interface that is responsible for processing network archiving tasks. The job consists of data describing the composite image objects selected for storage and the destination. An association is negotiated with the destination application entity and the image data is transferred using the C-STORE DIMSE-Service. Status of the transfer is reported to the job control interface.

The Storage SCP component of the Siemens Somaris/5 DICOM application is operating as background server process. It is existing, when the machine is powered on and waits for Storage association requests. Upon accepting an association with a negotiated Presentation Context it starts to receive the Composite Image Objects and imports them to local database. Verification requests will be processed and responded to by Storage SCP component, too.

Sequencing of Real-World Activities

Not applicable.

Storage Commitment

The Storage Commitment service class defines an application-level class of service which facilitates the commitment to storage. It performs an additional task of commitment of composite objects apart from the network based storage of images as defined by the Storage Service class. The Somaris/5 DICOM implementation supports the Storage Commitment Push Model as SCU.

Application Data Flow Diagram

The Somaris/5 DICOM network implementation acts as SCU for the Storage Commitment Push Model Service using the Storage Commitment Service Class. The product target operating system is Windows XP.

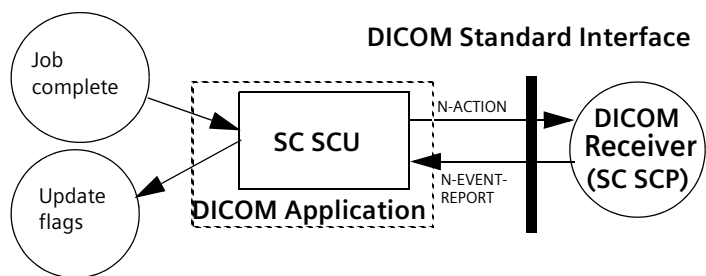

Functional Definitions of Application Entities

With each successfully completed send job the Somaris/5 DICOM application will create a Storage Commitment Push Model Identifier from the SOP Instances sent. Then a Storage Commit Request is triggered. Depending on configuration, the Somaris/5 DICOM application will keep the association open for responses with a configurable time-out, or closes the association and expects responses on a different association that has to be established by the remote Storage Commitment SCP.

The commitment status derived from the related trigger response will be indicated in the Status Flags of the related entry. It is possible to create triggers ("auto rules") from this event.

The Transaction UIDs of the pending commitment request are kept "open" for a configurable amount in time (default: 1h). If the "open time" for a pending commitment request has elapsed without a related response from the provider, the Transaction UID is removed and the related entities are indicated as "commit failed".

In any case, commitment will only be requested for previously and successfully sent images.

Sequencing of real World Activities

The Storage Commitment trigger is automatically derived from the successful completion of a Send job.

Query/Retrieve

The query/retrieve service class defines an application-level class of services which facilitates the management of images and patient data against the well defined information model of DICOM and allows a DICOM AE to retrieve images from a remote DICOM node or to request a remote DICOM AE to initiate a transfer of images to another DICOM AE. The DICOM query/retrieve application supports the query/retrieve services to act as SCU and SCP.

Application Data Flow Diagram

The Somaris/5 DICOM network implementation acts as SCU and SCP for the query/retrieve network service. The product target operating system is Windows XP.

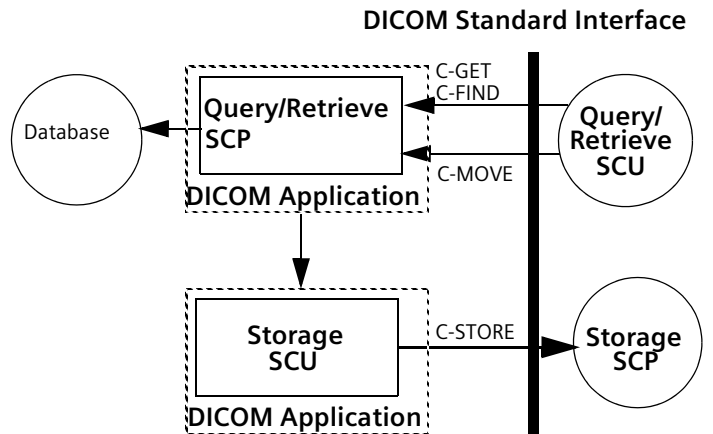
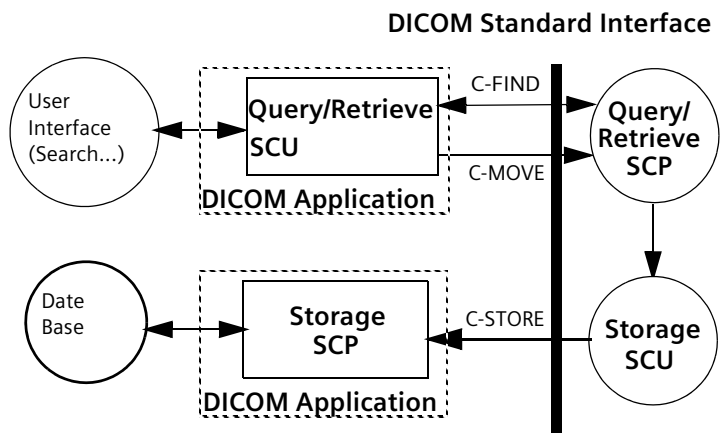

Functional Definitions of Application Entities

The query/retrieve SCU requests the remote query/retrieve SCP to perform a search and match to the keys specified in the request in order to display the results in the user interface. Depending on user action (Import) the Somaris/5 DICOM SCU sends a C-MOVE DIMSE service to initiate a C-STORE sub-operation on the SCP to start an image transfer from the remote Storage SCU to the Somaris/5 DICOM Storage SCP.

The query/retrieve SCP responds to C-FIND DIMSE services from remote SCU applications. Depending on further remote request, a C-GET or a C-MOVE involves the Somaris/5 DICOM query/retrieve SCP application to initiate a C-STORE association (by triggering and parameterizing the own Storage SCU) to send image objects to a remote Storage SCP.

All components of the Somaris/5 DICOM query/retrieve SCP application are operating as background server processes. They are existing when the machine is powered on and then respond to queries based on the records stored in its database.

Note

The Somaris/5 DICOM query/retrieve SCU application will execute new queries based upon the data found in the higher level query. For details see → Page A.2–47.

Sequencing of Real-World Activities

Retrieve of images is only possible if results from a previous "Search..." operation exist and those entities can be selected for "Import".

Print

The Print Management Service Classes define an application-level class of services which facilitate the printing of images on a hardcopy medium. The print management SCU and print management SCP are peer DICOM print management application entities. The DICOM print application supports the print management DIMSE services to act as SCU.

Application Data Flow Diagram

The Somaris/5 DICOM network implementation acts as SCU for the print management network service. The product target operating system is Windows XP.

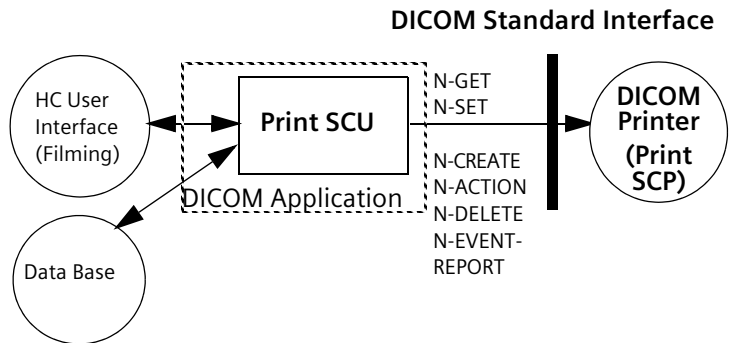

Functional Definitions of Application Entities

The Print SCU is invoked by the user interface to set up film sheet layout and whenever an image is ready to be printed on film. The print SCU will hold and maintain all data needed to compile a complete film sheet from the data (images, layout, configuration) received. Whenever a film sheet is ready to print the related data is used to supply the information to the SOP Classes of the Print Management Service Class. A queue is maintained in order to intermediately store several film sheets in case of resource problems on printer. The SCU will only supply and require the mandatory SOP Classes of the Print Management Service Class.

Sequencing of Real-World Activities

Not applicable.

Worklist

The Basic Worklist Service Class defines an application-level class of service which facilitates the transfer of worklists from the information system to the imaging modality. The worklist is queried by the AE and supplies the SCU with the scheduled tasks, which have to be performed on the modality. The DICOM worklist application supports the worklist service as SCU.

Application Data Flow Diagram

The Somaris/5 DICOM network implementation acts as SCU for the Basic Worklist Service using the Modality Worklist SOP Class. The product target operating system is Windows XP.

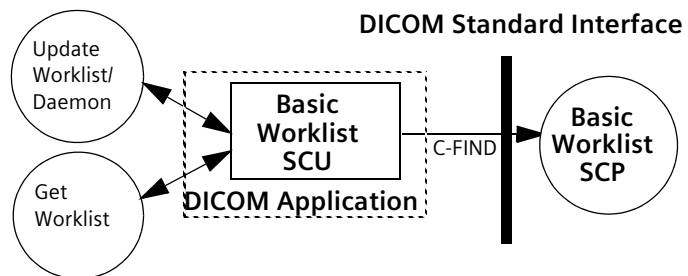

Note: It is configurable to get the worklist updates either automatically (in a configurable time interval) or manually (initiated by the user). There are two kinds of query the user can do: broad worklist query (all jobs for the own modality or own application entity) and patient based worklist query (where more search keys can be given, including Patient Name and Patient ID).

Functional Definitions of Application Entities

The worklist SCU ("broad query") is invoked from the patient browser user interface or by timer to request the worklist from a remote Information System (Modality Worklist SCP). This is done to perform a match to the internal worklist query keys specified in the C-FIND DIMSE service issued for the Modality Worklist Model.

The Worklist SCP responds to the C-FIND query and scheduled imaging service requests (scheduled procedure steps) and patient demographic information will be downloaded from the information system to the Somaris/5 modality. All information retrieved will be held in the scheduling database for usage during patient registration procedure.

Sequencing of Real-World Activities

The "narrow" (patient based) Worklist Query requires that sufficient matching keys or a unique matching key are/is entered before the query is issued. Only then a single response can be expected to complete the registration dialog.

Modality Performed Procedure Step

The Modality Performed Procedure Step service class defines an application-level class of service which facilitates the transfer of billing and radiation dose information from the imaging modality to the information system. The performed procedure step is created and set by the AE and supplies the SCP with the information about a real world procedure which is performed on the modality. The DICOM Modality Performed Procedure Step application supports the MPPS service as SCU.

Application Data Flow Diagram

The Somaris/5 DICOM network implementation is acts as SCU for the performed procedure step network service. The target operating system is Windows XP.

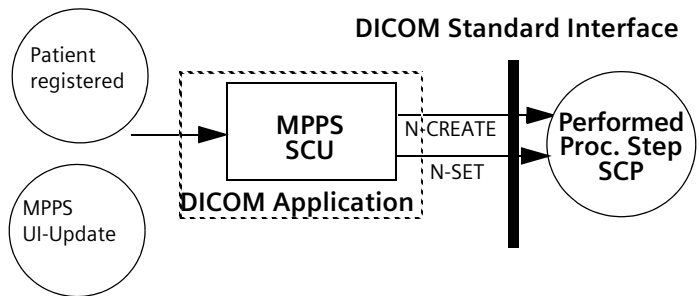

Functional Definitions of Application Entities

With registration of a patient (i.e. a Scheduled Procedure Step from Worklist), the Somaris/5 DICOM application will create a MPPS instance and communicate it to the MPPS SCP.

Furthermore a manual update can be performed with the Somaris/5 MPPS user interface. Only there it is possible to set the state of the MPPS to "Completed" or "Discontinued". If done so, the DICOM application will no longer allow updates on the related MPPS Instance.

Somaris/5 will not only allow a "1:1 relationship" of Scheduled Procedure Steps and Performed Procedure Steps, but also supports the "group case" (grouping several SPS of the same or different Requested Procedures) and "append case" from the respective IHE scenarios.

Somaris/5 supports creation of "unscheduled cases" by allowing MPPS instances to be communicated for locally registered patients.

Sequencing of real World Activities

Not applicable.

Verification AE Specification

Association Establishment Policies

General

The Somaris/5 DICOM Service Tool application attempts to initiate a new open an association for verification request whenever the "verification" function is activated during network configuration of a remote DICOM application.

Number of Associations

The Somaris/5 DICOM Service Tool application initiates several associations one association at a time, one for each destination time to which a transfer request is being processed in the active job queue listverification.

Asynchronous Nature

The Somaris/5 DICOM implementation Service Tool application does not support asynchronous communication (multiple outstanding transactions over a single association).

Implementation Identifying Information

The Somaris/5 DICOM implementation Service Tool application provides the Implementation Class UID of

❑ "1.3.12.2.1107.5.1.4"

and an Implementation Version Name of

❑ "SIEMENS_S5VB41A".

Association Initiation by Real-World Activity

The Somaris/5 DICOM Service Tool application attempts to initiate a new association for

- ❑ DIMSE C-ECHO service operations.

Associated Real-World Activity - Verification

Associated Real-World Activity - Verification SCU

The associated Real-World activity is a C-ECHO request initiated by the Service and Configuration SW environment whenever a "verification" is requested. If an association to a remote Application Entity is successfully established, Verification with the configured AET is requested via the open association. If the C-ECHO Response from the remote Application contains a status other than "Success" this will be indicated in the service environment and the association is closed.

Proposed Presentation Contexts - Verification SCU

The Somaris/5 DICOM application will propose Presentation Contexts as shown in the following table:

Presentation Context Table

Abstract Syntax		Transfer Syntax		Role	Extended Negotiation
Name	UID	Name List	UID List		
Verification	1.2.840.10008.1.1	Implicit VR Little Endian	1.2.840.10008.1.2	SCU	None
		Explicit VR Big Endian	1.2.840.10008.1.2.2		
		Explicit VR Little Endian	1.2.840.10008.1.2.1		

SOP Specific Conformance Statement - Verification SCU

The Application conforms to the definition of a Verification SCU in accordance to the DICOM Standard.

Association Acceptance Policy

The Verification SCP is part of the Storage SCP – see
→ page A.2–17, *Association Acceptance Policy*.

Storage AE Specification

The Somaris/5 Storage service class user applications and service class provider applications use one AE when initiating/receiving associations to/from remote DICOM nodes.

The SIEMENS Somaris/5 DICOM implementation provides Standard Conformance to the following DICOM V3.0 SOP Classes as both an SCU and SCP:

SOP Class Name	SOP Class UID
Computed Radiography Image Storage	1.2.840.10008.5.1.4.1.1.1
Digital X-Ray Image Storage - For Presentation	1.2.840.10008.5.1.4.1.1.1.1
Digital X-Ray Image Storage - For Processing	1.2.840.10008.5.1.4.1.1.1.1.1
Digital Mammography X-Ray Image Storage - For Presentation	1.2.840.10008.5.1.4.1.1.1.2
Digital Mammography X-Ray Image Storage - For Processing	1.2.840.10008.5.1.4.1.1.1.2.1
Digital Intra-oral X-Ray Image Storage - For Presentation	1.2.840.10008.5.1.4.1.1.1.3
Digital Intra-oral X-Ray Image Storage - For Processing	1.2.840.10008.5.1.4.1.1.1.3.1
Computed Tomography Image Storage	1.2.840.10008.5.1.4.1.1.2

SOP Class Name	SOP Class UID
UltraSound Multi-Frame Image Storage (retired) (SCP only)	1.2.840.10008.5.1.4.1.1.3
UltraSound Multi-Frame Image Storage	1.2.840.10008.5.1.4.1.1.3.1
Magnetic Resonance Image Storage	1.2.840.10008.5.1.4.1.1.4
UltraSound Image Storage (retired) (SCP only)	1.2.840.10008.5.1.4.1.1.6
UltraSound Image Storage	1.2.840.10008.5.1.4.1.1.6.1
Secondary Capture Image Storage	1.2.840.10008.5.1.4.1.1.7
12-lead ECG Waveform Storage	1.2.840.10008.5.1.4.1.1.9.1.1
General ECG Waveform Storage	1.2.840.10008.5.1.4.1.1.9.1.2
Ambulatory ECG Waveform Storage	1.2.840.10008.5.1.4.1.1.9.1.3
Hemodynamic Waveform Storage	1.2.840.10008.5.1.4.1.1.9.2.1
Cardiac Electrophysiology Waveform Storage	1.2.840.10008.5.1.4.1.1.9.3.1
Basic Voice Audio Waveform Storage	1.2.840.10008.5.1.4.1.1.9.4.1
X-Ray Angiographic Image Storage	1.2.840.10008.5.1.4.1.1.12.1
X-Ray RadioFluoroscopic Image Storage	1.2.840.10008.5.1.4.1.1.12.2
Nuclear Medicine Image Storage	1.2.840.10008.5.1.4.1.1.20

SOP Class Name	SOP Class UID
Basic Text SR	1.2.840.10008.5.1.4.1.1.88.11
Enhanced SR	1.2.840.10008.5.1.4.1.1.88.22
Comprehensive SR	1.2.840.10008.5.1.4.1.1.88.33
Procedure Log	1.2.840.10008.5.1.4.1.1.88.40
Mammography CAD SR	1.2.840.10008.5.1.4.1.1.88.50
Chest CAD SR	1.2.840.10008.5.1.4.1.1.88.65
X-Ray Radiation Dose SR	1.2.840.10008.5.1.4.1.1.88.67
PET Image Storage	1.2.840.10008.5.1.4.1.1.128
Radio Therapy Image Storage	1.2.840.10008.5.1.4.1.1.481.1
Radio Therapy Dose Storage	1.2.840.10008.5.1.4.1.1.481.2
Radio Therapy Structure Set Storage	1.2.840.10008.5.1.4.1.1.481.3
Radio Therapy Plan Storage	1.2.840.10008.5.1.4.1.1.481.5
Radio Therapy Ion Plan Storage	1.2.840.10008.5.1.4.1.1.481.8
Radio Therapy Ion Beams Treatment Record Storage	1.2.840.10008.5.1.4.1.1.481.9
Verification (only SCP)	1.2.840.10008.1.1

Somaris/5 DICOM implementation provides Private Conformance to the following DICOM V3.0 conform Private SOP Classes as both an SCU and SCP:

SOP Class Name	SOP Class UID
CSA Non-Image Storage	1.3.12.2.1107.5.9.1

Association Establishment Policies

General

The existence of a job queue with network destination or an internal trigger from processing a retrieve request will activate the DICOM Storage Application. An association request is sent to the destination AE and upon successful negotiation of a Presentation Context the transfer is started.

The default PDU size will be 28 KB.

Number of Associations

The Somaris/5 DICOM application initiates several associations at a time, one for each destination to which a transfer request is being processed in the active job queue list.

The Somaris/5 DICOM application is able to accept multiple associations at a time. It can handle up to 10 associations in parallel.

The number of Simultaneous DICOM associations can be configured via the Service-UI. The dialog can be found in Configuration / DICOM / General.

Asynchronous Nature

The Somaris/5 DICOM application does not support asynchronous communication (multiple outstanding transactions over a single association).

Implementation Identifying Information

The Somaris/5 DICOM implementation provides the Implementation Class UID of

❑ "1.3.12.2.1107.5.1.4"

and an Implementation Version Name of

❑ "SIEMENS_S5VB41A".

Associated Real-World Activity - Send Image Objects to a Network Destination*Association Initiation Policy*

If a job with network destination becomes active in the job list or a retrieve sub-operation is processed the Somaris/5 DICOM application attempts to initiate a new association for

- DIMSE C-STORE

service operations.

Associated Real-World Activity - Send (Storage SCU)

The associated Real-World activities are:

- A user wants to send one or more composite objects to a remote node. A job with network destination triggers an internal process, which initiates a C-STORE request.
- A user on a remote node wants to retrieve one or more composite objects: The local C-MOVE SCP initiates C-STORE suboperations as a reaction to a C-MOVE-RQ coming from a remote node.

For both cases, if the process successfully establishes an association to a remote Application Entity, it will transfer each image one after another via the open association. If the C-STORE Response from the remote Application contains a status other than "Success" or "Warning", the association is aborted or released.

Proposed Presentation Contexts - Send Images (Storage SCU)

The Somaris/5 DICOM application will propose Presentation Contexts as shown in the following table:

Presentation Context Table

Abstract Syntax		Transfer Syntax		Role	Extended
Name	UID	Name List	UID List		Negotiation
Computed Radiography Image	1.2.840.10008.5.1.4.1.1.1	Implicit VR Little Endian	1.2.840.10008.1.2	SCU	None
		Explicit VR Little Endian	1.2.840.10008.1.2.1		
		Explicit VR Big Endian	1.2.840.10008.1.2.2		
		JPEG Lossy Baseline (Process 1)	1.2.840.10008.1.2.4.50		
		JPEG Lossy Extended (2 & 4)	1.2.840.10008.1.2.4.51		
		JPEG Lossless, Process 14 (selection value 1)	1.2.840.10008.1.2.4.70		
Digital X-Ray Image for presentation	1.2.840.10008.5.1.4.1.1.1.1	Implicit VR Little Endian	1.2.840.10008.1.2	SCU	None
		Explicit VR Little Endian	1.2.840.10008.1.2.1		
		Explicit VR Big Endian	1.2.840.10008.1.2.2		
		JPEG Lossy Baseline (Process 1)	1.2.840.10008.1.2.4.50		
		JPEG Lossy Extended (2 & 4)	1.2.840.10008.1.2.4.51		
		JPEG Lossless, Process 14 (selection value 1)	1.2.840.10008.1.2.4.70		
Digital X-Ray Image for processing	1.2.840.10008.5.1.4.1.1.1.1.1	Implicit VR Little Endian	1.2.840.10008.1.2	SCU	None
		Explicit VR Little Endian	1.2.840.10008.1.2.1		
		Explicit VR Big Endian	1.2.840.10008.1.2.2		
		JPEG Lossy Baseline (Process 1)	1.2.840.10008.1.2.4.50		
		JPEG Lossy Extended (2 & 4)	1.2.840.10008.1.2.4.51		
		JPEG Lossless, Process 14 (selection value 1)	1.2.840.10008.1.2.4.70		

Digital MammoGraphy X-Ray Image for presentation	1.2.840.10008.5.1.4.1.1.1.2	Implicit VR Little Endian Explicit VR Little Endian Explicit VR Big Endian JPEG Lossy Baseline (Process 1) JPEG Lossy Extended (2 & 4) JPEG Lossless, Process 14 (selection value 1)	1.2.840.10008.1.2 1.2.840.10008.1.2.1 1.2.840.10008.1.2.2 1.2.840.10008.1.2.4.50 1.2.840.10008.1.2.4.51 1.2.840.10008.1.2.4.70	SCU	None
Digital MammoGraphy X-Ray Image for processing	1.2.840.10008.5.1.4.1.1.1.2.1	Implicit VR Little Endian Explicit VR Little Endian Explicit VR Big Endian JPEG Lossy Baseline (Process 1) JPEG Lossy Extended (2 & 4) JPEG Lossless, Process 14 (selection value 1)	1.2.840.10008.1.2 1.2.840.10008.1.2.1 1.2.840.10008.1.2.2 1.2.840.10008.1.2.4.50 1.2.840.10008.1.2.4.51 1.2.840.10008.1.2.4.70	SCU	None
Digital Intra- oral X-Ray Image for presentation	1.2.840.10008.5.1.4.1.1.1.3	Implicit VR Little Endian Explicit VR Little Endian Explicit VR Big Endian JPEG Lossy Baseline (Process 1) JPEG Lossy Extended (2 & 4) JPEG Lossless, Process 14 (selection value 1)	1.2.840.10008.1.2 1.2.840.10008.1.2.1 1.2.840.10008.1.2.2 1.2.840.10008.1.2.4.50 1.2.840.10008.1.2.4.51 1.2.840.10008.1.2.4.70	SCU	None
Digital Intra- oral X-Ray Image for processing	1.2.840.10008.5.1.4.1.1.1.3.1	Implicit VR Little Endian Explicit VR Little Endian Explicit VR Big Endian JPEG Lossy Baseline (Process 1) JPEG Lossy Extended (2 & 4) JPEG Lossless, Process 14 (selection value 1)	1.2.840.10008.1.2 1.2.840.10008.1.2.1 1.2.840.10008.1.2.2 1.2.840.10008.1.2.4.50 1.2.840.10008.1.2.4.51 1.2.840.10008.1.2.4.70	SCU	None



Computed Tomography Image	1.2.840.10008.5.1.4.1.1.2	Implicit VR Little Endian	1.2.840.10008.1.2	SCU	None
		Explicit VR Little Endian	1.2.840.10008.1.2.1		
		Explicit VR Big Endian	1.2.840.10008.1.2.2		
		JPEG Lossy Baseline (Process 1)	1.2.840.10008.1.2.4.50		
		JPEG Lossy Extended (2 & 4)	1.2.840.10008.1.2.4.51		
		JPEG Lossless, Process 14 (selection value 1)	1.2.840.10008.1.2.4.70		
UltraSound Multi-Frame Image	1.2.840.10008.5.1.4.1.1.3.1	Implicit VR Little Endian	1.2.840.10008.1.2	SCU	None
		Explicit VR Little Endian	1.2.840.10008.1.2.1		
		Explicit VR Big Endian	1.2.840.10008.1.2.2		
		JPEG Lossy Baseline (Process 1)	1.2.840.10008.1.2.4.50		
		JPEG Lossy Extended (2 & 4)	1.2.840.10008.1.2.4.51		
		JPEG Lossless, Process 14 (selection value 1)	1.2.840.10008.1.2.4.70		
Magnetic Resonance Image	1.2.840.10008.5.1.4.1.1.4	Implicit VR Little Endian	1.2.840.10008.1.2	SCU	None
		Explicit VR Little Endian	1.2.840.10008.1.2.1		
		Explicit VR Big Endian	1.2.840.10008.1.2.2		
		JPEG Lossy Baseline (Process 1)	1.2.840.10008.1.2.4.50		
		JPEG Lossy Extended (2 & 4)	1.2.840.10008.1.2.4.51		
		JPEG Lossless, Process 14 (selection value 1)	1.2.840.10008.1.2.4.70		
UltraSound Image	1.2.840.10008.5.1.4.1.1.6.1	Implicit VR Little Endian	1.2.840.10008.1.2	SCU	None
		Explicit VR Little Endian	1.2.840.10008.1.2.1		
		Explicit VR Big Endian	1.2.840.10008.1.2.2		
		JPEG Lossy Baseline (Process 1)	1.2.840.10008.1.2.4.50		
		JPEG Lossy Extended (2 & 4)	1.2.840.10008.1.2.4.51		
		JPEG Lossless, Process 14 (selection value 1)	1.2.840.10008.1.2.4.70		

Secondary Capture Image	1.2.840.10008.5.1.4.1.1.7	Implicit VR Little Endian	1.2.840.10008.1.2	SCU	None
		Explicit VR Little Endian	1.2.840.10008.1.2.1		
		Explicit VR Big Endian	1.2.840.10008.1.2.2		
		JPEG Lossy Baseline (Process 1)	1.2.840.10008.1.2.4.50		
		JPEG Lossy Extended (2 & 4)	1.2.840.10008.1.2.4.51		
		JPEG Lossless, Process 14 (selection value 1)	1.2.840.10008.1.2.4.70		
Waveform 12-lead ECG Object	1.2.840.10008.5.1.4.1.1.9.1.1	Implicit VR Little Endian	1.2.840.10008.1.2	SCU	None
		Explicit VR Big Endian	1.2.840.10008.1.2.2		
		Explicit VR Little Endian	1.2.840.10008.1.2.1		
Waveform General ECG Object	1.2.840.10008.5.1.4.1.1.9.1.2	Implicit VR Little Endian	1.2.840.10008.1.2	SCU	None
		Explicit VR Big Endian	1.2.840.10008.1.2.2		
		Explicit VR Little Endian	1.2.840.10008.1.2.1		
Waveform Ambulatory ECG Object	1.2.840.10008.5.1.4.1.1.9.1.3	Implicit VR Little Endian	1.2.840.10008.1.2	SCU	None
		Explicit VR Big Endian	1.2.840.10008.1.2.2		
		Explicit VR Little Endian	1.2.840.10008.1.2.1		
Waveform Hemodynamic Object	1.2.840.10008.5.1.4.1.1.9.2.1	Implicit VR Little Endian	1.2.840.10008.1.2	SCU	None
		Explicit VR Big Endian	1.2.840.10008.1.2.2		
		Explicit VR Little Endian	1.2.840.10008.1.2.1		
Waveform Cardiac Electro- physiology Object	1.2.840.10008.5.1.4.1.1.9.3.1	Implicit VR Little Endian	1.2.840.10008.1.2	SCU	None
		Explicit VR Big Endian	1.2.840.10008.1.2.2		
		Explicit VR Little Endian	1.2.840.10008.1.2.1		
Waveform Basic Audio Object	1.2.840.10008.5.1.4.1.1.9.4.1	Implicit VR Little Endian	1.2.840.10008.1.2	SCU	None
		Explicit VR Big Endian	1.2.840.10008.1.2.2		
		Explicit VR Little Endian	1.2.840.10008.1.2.1		
X-Ray Angiographic Image	1.2.840.10008.5.1.4.1.1.12.1	Implicit VR Little Endian	1.2.840.10008.1.2	SCU	None
		Explicit VR Little Endian	1.2.840.10008.1.2.1		
		Explicit VR Big Endian	1.2.840.10008.1.2.2		
		JPEG Lossy Baseline (Process 1)	1.2.840.10008.1.2.4.50		
		JPEG Lossy Extended (2 & 4)	1.2.840.10008.1.2.4.51		
		JPEG Lossless, Process 14 (selection value 1)	1.2.840.10008.1.2.4.70		

X-Ray Radio Fluoro-scopic Image	1.2.840.10008.5.1.4.1.1.12.2	Implicit VR Little Endian	1.2.840.10008.1.2	SCU	None
		Explicit VR Little Endian	1.2.840.10008.1.2.1		
		Explicit VR Big Endian	1.2.840.10008.1.2.2		
		JPEG Lossy Baseline (Process 1)	1.2.840.10008.1.2.4.50		
		JPEG Lossy Extended (2 & 4)	1.2.840.10008.1.2.4.51		
		JPEG Lossless, Process 14 (selection value 1)	1.2.840.10008.1.2.4.70		
Nuclear Medicine Image	1.2.840.10008.5.1.4.1.1.20	Implicit VR Little Endian	1.2.840.10008.1.2	SCU	None
		Explicit VR Little Endian	1.2.840.10008.1.2.1		
		Explicit VR Big Endian	1.2.840.10008.1.2.2		
		JPEG Lossy Baseline (Process 1)	1.2.840.10008.1.2.4.50		
		JPEG Lossy Extended (2 & 4)	1.2.840.10008.1.2.4.51		
		JPEG Lossless, Process 14 (selection value 1)	1.2.840.10008.1.2.4.70		
Basic Text SR	1.2.840.10008.5.1.4.1.1.88.11	Implicit VR Little Endian	1.2.840.10008.1.2	SCU	None
		Explicit VR Little Endian	1.2.840.10008.1.2.1		
		Explicit VR Big Endian	1.2.840.10008.1.2.2		
Enhanced SR	1.2.840.10008.5.1.4.1.1.88.22	Implicit VR Little Endian	1.2.840.10008.1.2	SCU	None
		Explicit VR Little Endian	1.2.840.10008.1.2.1		
		Explicit VR Big Endian	1.2.840.10008.1.2.2		
Comprehensive SR	1.2.840.10008.5.1.4.1.1.88.33	Implicit VR Little Endian	1.2.840.10008.1.2	SCU	None
		Explicit VR Little Endian	1.2.840.10008.1.2.1		
		Explicit VR Big Endian	1.2.840.10008.1.2.2		
Mammography CAD SR	1.2.840.10008.5.1.4.1.1.88.55	Implicit VR Little Endian	1.2.840.10008.1.2	SCU	None
		Explicit VR Little Endian	1.2.840.10008.1.2.1		
		Explicit VR Big Endian	1.2.840.10008.1.2.2		
Chest CAD SR	1.2.840.10008.5.1.4.1.1.88.65	Implicit VR Little Endian	1.2.840.10008.1.2	SCU	None
		Explicit VR Little Endian	1.2.840.10008.1.2.1		
		Explicit VR Big Endian	1.2.840.10008.1.2.2		
X-Ray Radiation Dose SR	1.2.840.10008.5.1.4.1.1.88.67	Implicit VR Little Endian	1.2.840.10008.1.2	SCU	None
		Explicit VR Little Endian	1.2.840.10008.1.2.1		
		Explicit VR Big Endian	1.2.840.10008.1.2.2		



PET Image	1.2.840.10008.5.1.4.1.1.128	Implicit VR Little Endian	1.2.840.10008.1.2	SCU	None
		Explicit VR Little Endian	1.2.840.10008.1.2.1		
		Explicit VR Big Endian	1.2.840.10008.1.2.2		
		JPEG Lossy Baseline (Process 1)	1.2.840.10008.1.2.4.50		
		JPEG Lossy Extended (2 & 4)	1.2.840.10008.1.2.4.51		
		JPEG Lossless, Process 14 (selection value 1)	1.2.840.10008.1.2.4.70		
RT Image	1.2.840.10008.5.1.4.1.1.481.1	Implicit VR Little Endian	1.2.840.10008.1.2	SCU	None
		Explicit VR Little Endian	1.2.840.10008.1.2.1		
		Explicit VR Big Endian	1.2.840.10008.1.2.2		
		JPEG Lossy Baseline (Process 1)	1.2.840.10008.1.2.4.50		
		JPEG Lossy Extended (2 & 4)	1.2.840.10008.1.2.4.51		
		JPEG Lossless, Process 14 (selection value 1)	1.2.840.10008.1.2.4.70		
RT Dose	1.2.840.10008.5.1.4.1.1.481.2	Implicit VR Little Endian	1.2.840.10008.1.2	SCU	None
		Explicit VR Little Endian	1.2.840.10008.1.2.1		
		Explicit VR Big Endian	1.2.840.10008.1.2.2		
		JPEG Lossy Baseline (Process 1)	1.2.840.10008.1.2.4.50		
		JPEG Lossy Extended (2 & 4)	1.2.840.10008.1.2.4.51		
		JPEG Lossless, Process 14 (selection value 1)	1.2.840.10008.1.2.4.70		
RT Structure Set	1.2.840.10008.5.1.4.1.1.481.3	Implicit VR Little Endian	1.2.840.10008.1.2	SCU	None
		Explicit VR Little Endian	1.2.840.10008.1.2.1		
		Explicit VR Big Endian	1.2.840.10008.1.2.2		
RT Plan	1.2.840.10008.5.1.4.1.1.481.5	Implicit VR Little Endian	1.2.840.10008.1.2	SCU	None
		Explicit VR Little Endian	1.2.840.10008.1.2.1		
		Explicit VR Big Endian	1.2.840.10008.1.2.2		
RT Brachy Treatment Record	1.2.840.10008.5.1.4.1.1.481.6	Implicit VR Little Endian	1.2.840.10008.1.2	SCU	None
		Explicit VR Little Endian	1.2.840.10008.1.2.1		
		Explicit VR Big Endian	1.2.840.10008.1.2.2		



RT Brachy Treatment Summary Record	1.2.840.10008.5.1.4.1.1.481.7	Implicit VR Little Endian	1.2.840.10008.1.2	SCU	None
		Explicit VR Little Endian	1.2.840.10008.1.2.1		
		Explicit VR Big Endian	1.2.840.10008.1.2.2		
RT Ion Plan	1.2.840.10008.5.1.4.1.1.481.8	Implicit VR Little Endian	1.2.840.10008.1.2	SCU	None
		Explicit VR Little Endian	1.2.840.10008.1.2.1		
		Explicit VR Big Endian	1.2.840.10008.1.2.2		
RT Ion Beams Treatment Record	1.2.840.10008.5.1.4.1.1.481.9	Implicit VR Little Endian	1.2.840.10008.1.2	SCU	None
		Explicit VR Little Endian	1.2.840.10008.1.2.1		
		Explicit VR Big Endian	1.2.840.10008.1.2.2		
CSA Non-Image	1.3.12.2.1107.5.9.1	Implicit VR Little Endian	1.2.840.10008.1.2	SCU	None
		Explicit VR Little Endian	1.2.840.10008.1.2.1		
		Explicit VR Big Endian	1.2.840.10008.1.2.2		

Note

Uncompressed transfer syntaxes are proposed together in a single presentation context for each abstract syntax.

The "MOVE" destinations must be configured as Storage destinations. This will include the configuration of Transfer Syntax capabilities.

SOP Specific Conformance Statement - Storage SCU

Not all the listed transfer syntaxes will be proposed all the time. For some abstract syntaxes only a list of uncompressed (UC) transfer syntaxes (one or more) will be proposed, for other abstract syntaxes also JPEG Lossless (LL) syntax will be proposed and/or a list of JPEG Lossy (LY) transfer syntaxes. The contents of this lists is configurable, e.g. UC could be configured to contain only Implicit Little Endian for instance. For further configuration details see → page A.5–3.

It is not possible to send an image that is locally stored in a Lossy compressed format using an uncompressed or lossless transfer syntax.

The DICOM images created by Somaris/5 DICOM application conform to the DICOM IOD definitions (Standard Extended IODs). But they will contain additional private elements which have to be discarded by a DICOM system when modifying the image.

The DICOM nodes are responsible for data consistency when modifying images. All unknown private attributes have to be removed upon modification!

Somaris/5 does not change private attributes if no modification is done. But during a *Save as* operation all non *syngo* defined private attributes will be removed. For association and DIMSE level time outs refer

→ page A.5–3, *Configurable Parameters*

Association Acceptance Policy

The Somaris/5 DICOM application attempts to accept a new association for

- DIMSE C-ECHO
- DIMSE C-STORE

service operations. Any Information Object transmitted on that association will be checked for conformance and stored in the database if check was successful.

Real-World Activity - Receive (Storage SCP)

The daemon receiving process will accept an association and will receive any images transmitted on that association and will store the images on disk in the own database if the conformance check is performed successfully.

**Associated Real-World
Activity - Receiving
Images from Remote Note
(Storage SCP)**

Proposed Presentation Contexts - Receiving Images (Storage SCP)

The Somaris/5 DICOM application will propose Presentation Contexts as shown in the following table:

Presentation Context Table

Abstract Syntax		Transfer Syntax		Role	Extended Negotiation
Name	UID	Name List	UID List		
Computed Radiography Image	1.2.840.10008.5.1.4.1.1.1	Implicit VR Little Endian	1.2.840.10008.1.2	SCP	None
		Explicit VR Little Endian	1.2.840.10008.1.2.1		
		Explicit VR Big Endian	1.2.840.10008.1.2.2		
		JPEG Lossy Baseline (Process 1)	1.2.840.10008.1.2.4.50		
		JPEG Lossy Extended (2 & 4)	1.2.840.10008.1.2.4.51		
		JPEG Lossless, Process 14 (selection value 1)	1.2.840.10008.1.2.4.70		
Digital X-Ray Image for presentation	1.2.840.10008.5.1.4.1.1.1.1	Implicit VR Little Endian	1.2.840.10008.1.2	SCP	None
		Explicit VR Little Endian	1.2.840.10008.1.2.1		
		Explicit VR Big Endian	1.2.840.10008.1.2.2		
		JPEG Lossy Baseline (Process 1)	1.2.840.10008.1.2.4.50		
		JPEG Lossy Extended (2 & 4)	1.2.840.10008.1.2.4.51		
		JPEG Lossless, Process 14 (selection value 1)	1.2.840.10008.1.2.4.70		
Digital X-Ray Image for processing	1.2.840.10008.5.1.4.1.1.1.1.1	Implicit VR Little Endian	1.2.840.10008.1.2	SCP	None
		Explicit VR Little Endian	1.2.840.10008.1.2.1		
		Explicit VR Big Endian	1.2.840.10008.1.2.2		
		JPEG Lossy Baseline (Process 1)	1.2.840.10008.1.2.4.50		
		JPEG Lossy Extended (2 & 4)	1.2.840.10008.1.2.4.51		
		JPEG Lossless, Process 14 (selection value 1)	1.2.840.10008.1.2.4.70		
		RLE Lossless	1.2.840.10008.1.2.2		



Digital MammoGraphy X-Ray Image for presentation	1.2.840.10008.5.1.4.1.1.1.2	Implicit VR Little Endian	1.2.840.10008.1.2	SCP	None
		Explicit VR Little Endian	1.2.840.10008.1.2.1		
		Explicit VR Big Endian	1.2.840.10008.1.2.2		
		JPEG Lossy Baseline (Process 1)	1.2.840.10008.1.2.4.50		
		JPEG Lossy Extended (2 & 4)	1.2.840.10008.1.2.4.51		
		JPEG Lossless, Process 14 (selection value 1)	1.2.840.10008.1.2.4.70		
		RLE Lossless	1.2.840.10008.1.2.2		
Digital MammoGraphy X-Ray Image for processing	1.2.840.10008.5.1.4.1.1.1.2.1	Implicit VR Little Endian	1.2.840.10008.1.2	SCP	None
		Explicit VR Little Endian	1.2.840.10008.1.2.1		
		Explicit VR Big Endian	1.2.840.10008.1.2.2		
		JPEG Lossy Baseline (Process 1)	1.2.840.10008.1.2.4.50		
		JPEG Lossy Extended (2 & 4)	1.2.840.10008.1.2.4.51		
		JPEG Lossless, Process 14 (selection value 1)	1.2.840.10008.1.2.4.70		
		RLE Lossless	1.2.840.10008.1.2.2		
Digital Intra-oral X-Ray Image for presentation	1.2.840.10008.5.1.4.1.1.1.3	Implicit VR Little Endian	1.2.840.10008.1.2	SCP	None
		Explicit VR Little Endian	1.2.840.10008.1.2.1		
		Explicit VR Big Endian	1.2.840.10008.1.2.2		
		JPEG Lossy Baseline (Process 1)	1.2.840.10008.1.2.4.50		
		JPEG Lossy Extended (2 & 4)	1.2.840.10008.1.2.4.51		
		JPEG Lossless, Process 14 (selection value 1)	1.2.840.10008.1.2.4.70		
		RLE Lossless	1.2.840.10008.1.2.2		
Digital Intra-oral X-Ray Image for processing	1.2.840.10008.5.1.4.1.1.1.3.1	Implicit VR Little Endian	1.2.840.10008.1.2	SCP	None
		Explicit VR Little Endian	1.2.840.10008.1.2.1		
		Explicit VR Big Endian	1.2.840.10008.1.2.2		
		JPEG Lossy Baseline (Process 1)	1.2.840.10008.1.2.4.50		
		JPEG Lossy Extended (2 & 4)	1.2.840.10008.1.2.4.51		
		JPEG Lossless, Process 14 (selection value 1)	1.2.840.10008.1.2.4.70		
		RLE Lossless	1.2.840.10008.1.2.2		



Computed Tomography Image	1.2.840.10008.5.1.4.1.1.2	Implicit VR Little Endian	1.2.840.10008.1.2	SCP	None
		Explicit VR Little Endian	1.2.840.10008.1.2.1		
		Explicit VR Big Endian	1.2.840.10008.1.2.2		
		JPEG Lossy Baseline (Process 1)	1.2.840.10008.1.2.4.50		
		JPEG Lossy Extended (2 & 4)	1.2.840.10008.1.2.4.51		
		JPEG Lossless, Process 14 (selection value 1)	1.2.840.10008.1.2.4.70		
		RLE Lossless	1.2.840.10008.1.2.2		
UltraSound Multi-Frame Image	1.2.840.10008.5.1.4.1.1.3.1	Implicit VR Little Endian	1.2.840.10008.1.2	SCP	None
	1.2.840.10008.5.1.4.1.1.3 (retired) *1	Explicit VR Little Endian	1.2.840.10008.1.2.1		
		Explicit VR Big Endian	1.2.840.10008.1.2.2		
		JPEG Lossy Baseline (Process 1)	1.2.840.10008.1.2.4.50		
		JPEG Lossy Extended (2 & 4)	1.2.840.10008.1.2.4.51		
		JPEG Lossless, Process 14 (selection value 1)	1.2.840.10008.1.2.4.70		
		RLE Lossless	1.2.840.10008.1.2.2		
Magnetic Resonance Image	1.2.840.10008.5.1.4.1.1.4	Implicit VR Little Endian	1.2.840.10008.1.2	SCP	None
		Explicit VR Little Endian	1.2.840.10008.1.2.1		
		Explicit VR Big Endian	1.2.840.10008.1.2.2		
		JPEG Lossy Baseline (Process 1)	1.2.840.10008.1.2.4.50		
		JPEG Lossy Extended (2 & 4)	1.2.840.10008.1.2.4.51		
		JPEG Lossless, Process 14 (selection value 1)	1.2.840.10008.1.2.4.70		
		RLE Lossless	1.2.840.10008.1.2.2		
UltraSound Image	1.2.840.10008.5.1.4.1.1.6.1	Implicit VR Little Endian	1.2.840.10008.1.2	SCP	None
	1.2.840.10008.5.1.4.1.1.6 (retired) *1	Explicit VR Little Endian	1.2.840.10008.1.2.1		
		Explicit VR Big Endian	1.2.840.10008.1.2.2		
		JPEG Lossy Baseline (Process 1)	1.2.840.10008.1.2.4.50		
		JPEG Lossy Extended (2 & 4)	1.2.840.10008.1.2.4.51		
		JPEG Lossless, Process 14 (selection value 1)	1.2.840.10008.1.2.4.70		
		RLE Lossless	1.2.840.10008.1.2.2		



Secondary Capture Image	1.2.840.10008.5.1.4.1.1.7	Implicit VR Little Endian	1.2.840.10008.1.2	SCP	None
		Explicit VR Little Endian	1.2.840.10008.1.2.1		
		Explicit VR Big Endian	1.2.840.10008.1.2.2		
		JPEG Lossy Baseline (Process 1)	1.2.840.10008.1.2.4.50		
		JPEG Lossy Extended (2 & 4)	1.2.840.10008.1.2.4.51		
Waveform 12-lead ECG Object	1.2.840.10008.5.1.4.1.1.9.1.1	JPEG Lossless, Process 14 (selection value 1)	1.2.840.10008.1.2.4.70	SCP	None
		RLE Lossless	1.2.840.10008.1.2.2		
		Implicit VR Little Endian	1.2.840.10008.1.2		
Waveform General ECG Object	1.2.840.10008.5.1.4.1.1.9.1.2	Explicit VR Big Endian	1.2.840.10008.1.2.2	SCP	None
		Explicit VR Little Endian	1.2.840.10008.1.2.1		
		Implicit VR Little Endian	1.2.840.10008.1.2		
Waveform Ambulatory ECG Object	1.2.840.10008.5.1.4.1.1.9.1.3	Explicit VR Big Endian	1.2.840.10008.1.2.2	SCP	None
		Explicit VR Little Endian	1.2.840.10008.1.2.1		
		Implicit VR Little Endian	1.2.840.10008.1.2		
Waveform Hemodynamic Object	1.2.840.10008.5.1.4.1.1.9.2.1	Explicit VR Big Endian	1.2.840.10008.1.2.2	SCP	None
		Explicit VR Little Endian	1.2.840.10008.1.2.1		
		Implicit VR Little Endian	1.2.840.10008.1.2		
Waveform Cardiac Electro-physiology Object	1.2.840.10008.5.1.4.1.1.9.3.1	Explicit VR Big Endian	1.2.840.10008.1.2.2	SCP	None
		Explicit VR Little Endian	1.2.840.10008.1.2.1		
		Implicit VR Little Endian	1.2.840.10008.1.2		
Waveform Basic Audio Object	1.2.840.10008.5.1.4.1.1.9.4.1	Explicit VR Big Endian	1.2.840.10008.1.2.2	SCP	None
		Explicit VR Little Endian	1.2.840.10008.1.2.1		
		Implicit VR Little Endian	1.2.840.10008.1.2		

X-Ray Angiographic Image	1.2.840.10008.5.1.4.1.1.12.1	Implicit VR Little Endian	1.2.840.10008.1.2	SCP	None
		Explicit VR Little Endian	1.2.840.10008.1.2.1		
		Explicit VR Big Endian	1.2.840.10008.1.2.2		
		JPEG Lossy Baseline (Process 1)	1.2.840.10008.1.2.4.50		
		JPEG Lossy Extended (2 & 4)	1.2.840.10008.1.2.4.51		
		JPEG Lossless, Process 14 (selection value 1)	1.2.840.10008.1.2.4.70		
		RLE Lossless	1.2.840.10008.1.2.2		
X-Ray RadioFluoroscopic Image	1.2.840.10008.5.1.4.1.1.12.2	Implicit VR Little Endian	1.2.840.10008.1.2	SCP	None
		Explicit VR Little Endian	1.2.840.10008.1.2.1		
		Explicit VR Big Endian	1.2.840.10008.1.2.2		
		JPEG Lossy Baseline (Process 1)	1.2.840.10008.1.2.4.50		
		JPEG Lossy Extended (2 & 4)	1.2.840.10008.1.2.4.51		
		JPEG Lossless, Process 14 (selection value 1)	1.2.840.10008.1.2.4.70		
		RLE Lossless	1.2.840.10008.1.2.2		
Nuclear Medicine Image	1.2.840.10008.5.1.4.1.1.20	Implicit VR Little Endian	1.2.840.10008.1.2	SCP	None
		Explicit VR Little Endian	1.2.840.10008.1.2.1		
		Explicit VR Big Endian	1.2.840.10008.1.2.2		
		JPEG Lossy Baseline (Process 1)	1.2.840.10008.1.2.4.50		
		JPEG Lossy Extended (2 & 4)	1.2.840.10008.1.2.4.51		
		JPEG Lossless, Process 14 (selection value 1)	1.2.840.10008.1.2.4.70		
		RLE Lossless	1.2.840.10008.1.2.2		
Basic Text SR	1.2.840.10008.5.1.4.1.1.88.11	Implicit VR Little Endian	1.2.840.10008.1.2	SCP	None
		Explicit VR Little Endian	1.2.840.10008.1.2.1		
		Explicit VR Big Endian	1.2.840.10008.1.2.2		
Enhanced SR	1.2.840.10008.5.1.4.1.1.88.22	Implicit VR Little Endian	1.2.840.10008.1.2	SCP	None
		Explicit VR Little Endian	1.2.840.10008.1.2.1		
		Explicit VR Big Endian	1.2.840.10008.1.2.2		
Comprehensive SR	1.2.840.10008.5.1.4.1.1.88.33	Implicit VR Little Endian	1.2.840.10008.1.2	SCP	None
		Explicit VR Little Endian	1.2.840.10008.1.2.1		
		Explicit VR Big Endian	1.2.840.10008.1.2.2		



Mammography CAD SR	1.2.840.10008.5.1.4.1.1.88.55	Implicit VR Little Endian	1.2.840.10008.1.2	SCP	None
		Explicit VR Little Endian	1.2.840.10008.1.2.1		
		Explicit VR Big Endian	1.2.840.10008.1.2.2		
Chest CAD SR	1.2.840.10008.5.1.4.1.1.88.65	Implicit VR Little Endian	1.2.840.10008.1.2	SCP	None
		Explicit VR Little Endian	1.2.840.10008.1.2.1		
		Explicit VR Big Endian	1.2.840.10008.1.2.2		
X-Ray Radiation Dose SR	1.2.840.10008.5.1.4.1.1.88.67	Implicit VR Little Endian	1.2.840.10008.1.2	SCP	None
		Explicit VR Little Endian	1.2.840.10008.1.2.1		
		Explicit VR Big Endian	1.2.840.10008.1.2.2		
PET Image	1.2.840.10008.5.1.4.1.1.128	Implicit VR Little Endian	1.2.840.10008.1.2	SCP	None
		Explicit VR Little Endian	1.2.840.10008.1.2.1		
		Explicit VR Big Endian	1.2.840.10008.1.2.2		
		JPEG Lossy Baseline (Process 1)	1.2.840.10008.1.2.4.50		
		JPEG Lossy Extended (2 & 4)	1.2.840.10008.1.2.4.51		
		JPEG Lossless, Process 14 (selection value 1)	1.2.840.10008.1.2.4.70		
		RLE Lossless	1.2.840.10008.1.2.2		
RT Image	1.2.840.10008.5.1.4.1.1.481.1	Implicit VR Little Endian	1.2.840.10008.1.2	SCP	None
		Explicit VR Little Endian	1.2.840.10008.1.2.1		
		Explicit VR Big Endian	1.2.840.10008.1.2.2		
		JPEG Lossy Baseline (Process 1)	1.2.840.10008.1.2.4.50		
		JPEG Lossy Extended (2 & 4)	1.2.840.10008.1.2.4.51		
		JPEG Lossless, Process 14 (selection value 1)	1.2.840.10008.1.2.4.70		
		RLE Lossless	1.2.840.10008.1.2.2		
RT Dose	1.2.840.10008.5.1.4.1.1.481.2	Implicit VR Little Endian	1.2.840.10008.1.2	SCP	None
		Explicit VR Little Endian	1.2.840.10008.1.2.1		
		Explicit VR Big Endian	1.2.840.10008.1.2.2		
		JPEG Lossy Baseline (Process 1)	1.2.840.10008.1.2.4.50		
		JPEG Lossy Extended (2 & 4)	1.2.840.10008.1.2.4.51		
		JPEG Lossless, Process 14 (selection value 1)	1.2.840.10008.1.2.4.70		
		RLE Lossless	1.2.840.10008.1.2.2		

RT Structure Set	1.2.840.10008.5.1.4.1.1.481.3	Implicit VR Little Endian	1.2.840.10008.1.2	SCP	None
		Explicit VR Little Endian	1.2.840.10008.1.2.1		
		Explicit VR Big Endian	1.2.840.10008.1.2.2		
RT Beams Treatment Record	1.2.840.10008.5.1.4.1.1.481.4	Implicit VR Little Endian	1.2.840.10008.1.2	SCP	None
		Explicit VR Little Endian	1.2.840.10008.1.2.1		
		Explicit VR Big Endian	1.2.840.10008.1.2.2		
RT Plan	1.2.840.10008.5.1.4.1.1.481.5	Implicit VR Little Endian	1.2.840.10008.1.2	SCP	None
		Explicit VR Little Endian	1.2.840.10008.1.2.1		
		Explicit VR Big Endian	1.2.840.10008.1.2.2		
RT Branchy Treatment Record	1.2.840.10008.5.1.4.1.1.481.6	Implicit VR Little Endian	1.2.840.10008.1.2	SCP	None
		Explicit VR Little Endian	1.2.840.10008.1.2.1		
		Explicit VR Big Endian	1.2.840.10008.1.2.2		
RT Treatment Summary Record	1.2.840.10008.5.1.4.1.1.481.7	Implicit VR Little Endian	1.2.840.10008.1.2	SCP	None
		Explicit VR Little Endian	1.2.840.10008.1.2.1		
		Explicit VR Big Endian	1.2.840.10008.1.2.2		
RT Ion Plan	1.2.840.10008.5.1.4.1.1.481.8	Implicit VR Little Endian	1.2.840.10008.1.2	SCP	None
		Explicit VR Little Endian	1.2.840.10008.1.2.1		
		Explicit VR Big Endian	1.2.840.10008.1.2.2		
RT Ion Beams Treatment Record	1.2.840.10008.5.1.4.1.1.481.9	Implicit VR Little Endian	1.2.840.10008.1.2	SCP	None
		Explicit VR Little Endian	1.2.840.10008.1.2.1		
		Explicit VR Big Endian	1.2.840.10008.1.2.2		
CSA Non-Image	1.3.12.2.1107.5.9.1	Implicit VR Little Endian	1.2.840.10008.1.2	SCP	None
		Explicit VR Little Endian	1.2.840.10008.1.2.1		
		Explicit VR Big Endian	1.2.840.10008.1.2.2		
Verification	1.2.840.10008.1.1	Implicit VR Little Endian	1.2.840.10008.1.2	SCP	None
		Explicit VR Little Endian	1.2.840.10008.1.2.1		
		Explicit VR Big Endian	1.2.840.10008.1.2.2		

***1:** US Retired and US Multiframe Retired images are converted to US images/US Multiframe images before storing them into the local database. The conversion creates new images, which implies new UIDs.

Note

With RLE Lossless Transfer Syntax the DICOM application will decompress the image before storing it into the database.

Note

JPEG 2000 decompression supported only for import in connection with COSMOS / *syngo* Imaging workplace.

Note

Private attributes in sequence items will be removed during import in *syngo*.

SOP Specific Conformance Statement - Receiving Images

The Somaris/5 DICOM application conforms to the Full Storage Service Class at Level 2.

Upon successfully receiving a C-STORE-RQ, the SIEMENS Somaris/5 DICOM receiver performs a quick plausibility test on the received image and available system resources. If this test succeeds, it returns the status SUCCESS, otherwise one of the following status codes is returned and the association is aborted:

❑ Refused (A700):

This error status indicates a lack of Resources (e.g. not enough disk space) on the Somaris/5 modality.

❑ Invalid Dataset (A900):

The dataset is not containing one of the attributes "Study Instance UID", "Series UID" or "SOP Instance UID", or one of them has an invalid value.

❑ Processing Error (0110 or C000):

An error occurred while processing the image which makes it impossible to proceed.

Attention! Only after sending the response, the image will be saved into the database. If an error occurs during this operation, the association will be aborted. This implies that a C-STORE-RSP with status SUCCESS does not mean that the image was successfully stored into the database.

In order to confirm that the images sent were successfully stored into the database, the sending application should use Storage Commitment Service.

If an image instance is received that is identified by a SOP Instance UID which is already used by an Instance stored in the database then the received image will be discarded. The existing image is not superseded. So if a remote node sends twice the same image (same SOP Instance UID) then there will still be only one image (the first) in the database of the DICOM receiver.

The following sections will differentiate the attribute contents required for Image Viewing. The Somaris/5 DICOM application supports more formats for Storage of images than Viewing.

Image Pixel Attribute Acceptance Criterion for Grayscale Images

The Display application accepts the MONOCHROME1 and MONOCHROME2 photometric interpretation pixel format and graphic overlay with unsigned integer and 8 or 16 bits allocated. Accepted values:

Pixel plane

- samples per pixel (attribute 0028, 0002) = 1
- photometric interpretation (attribute 0028,0004) = "MONOCHROME1"
- photometric interpretation (attribute 0028,0004) = "MONOCHROME2"
- pixel representation (attribute 0028, 0103) = 0 (unsigned)
- bits allocated (attribute 0028, 0100) = 8, 16
- bits stored (attribute 0028,0101) = 8, 10, 12, 14, 15, 16
- high bit (attribute 0028,0102) = bits stored - 1
- only aspect ratio (attribute 0028,0034) 1:1 is supported

Overlay plane

- overlay type (attribute 60xx, 0040) = "G"
- overlay bits allocated (attribute 60xx, 0100) = 16
- overlay bit position (attribute 60xx, 0102) = 12, 13, 14, 15 (only bits above high bit permitted)
- Graphic Overlay will be shifted to fill Overlay Planes from Bit 12 and consecutive.

Overlay plane

- overlay type (attribute 60xx, 0040) = "G"
- overlay bits allocated (attribute 60xx, 0100) = 1
- overlay bit position (attribute 60xx, 0102) = 0
- overlay data (attribute 60xx, 3000) = supported

The Somaris/5 DICOM application accepts also the MONOCHROME1 and MONOCHROME2 photometric interpretation pixel format with binary 2's complement integer and 16 bits allocated. Accepted values:

Pixel plane

- samples per pixel (attribute 0028, 0002) = 1
- photometric interpretation (attribute 0028,0004) = "MONOCHROME1"
- photometric interpretation (attribute 0028,0004) = "MONOCHROME2"
- pixel representation (attribute 0028, 0103) = 1 (signed)
- bits allocated (attribute 0028, 0100) = 16
- bits stored (attribute 0028,0101) = 16
- high bit (attribute 0028,0102) = 15
- only aspect ratio (attribute 0028,0034) 1:1 is supported

Overlay plane

- overlay type (attribute 60xx, 0040) = "G"
- overlay bits allocated (attribute 60xx, 0100) = 1
- overlay bit position (attribute 60xx, 0102) = 0
- overlay data (attribute 60xx, 3000) = supported

For MOD LUT both the linear LUT (Rescale Slope/Intercept) and the MOD LUT SQ are supported and considered when pixel data is displayed. However there are two limitations. The MOD LUT SQ will be ignored in the following cases:

- 8 bit signed pixels
- The pixel format is changed by the MOD LUT (e.g. 8 bit -> 16 bit).
- If the MOD LUT SQ contains multiple LUTs then only the first one is used.

For VOI LUT also both the linear LUT (Window Center/Width) and the VOI LUT SQ are supported (VOI LUT SQ with 8 or 16 bit LUT data).

But if both a VOI LUT SQ and a linear MOD LUT are specified within one image, then the value of Rescale Slope is restricted to 1.

If the VOI LUT SQ contains multiple LUTs, then only the first one is used by default. The other VOI LUTs are selectable.

In this version the Display application supports only rectangular and circular Shutters. Images with other shutter types will be displayed without Shutter.

Image Pixel Attribute Acceptance Criterion for Color Images

The Siemens Display application supports the RGB color image description with the unsigned integer 24 bit color image plane pixel format. Accepted values:

- samples per pixel (attribute 0028, 0002) = 3
- photometric interpretation (attribute 0028,0004) = "RGB"
- pixel representation (attribute 0028, 0103) = 0
- bits allocated (attribute 0028, 0100) = 8
- bits stored (attribute 0028,0101) = 8
- high bit (attribute 0028,0102) = 7
- planar configuration (attribute 0028,0006) = 0 (pixel interleave) or 1 (plane interleave)

The Siemens Display application supports the "Palette Color" color image description with unsigned integer and 2's complement pixel format:

- samples per pixel (attribute 0028, 0002) = 1
- photometric interpretation (attribute 0028,0004) = "PALETTE COLOR"
- pixel representation (attribute 0028, 0103) = 0
- bits allocated (attribute 0028, 0100) = 8 and bits stored (attribute 0028,0101) = 8
- bits allocated (attribute 0028, 0100) = 16 and bits stored (attribute 0028,0101) = 16
- high bit (attribute 0028,0102) = 7, 15

Both 8bit and 16bit palettes are supported - but no Segmented Palette Color LUTs.

The Siemens Display application supports the YBR_FULL color image description with the unsigned integer pixel format.

Accepted values:

- samples per pixel (attribute 0028, 0002) = 3
- photometric interpretation (attribute 0028,0004) = "YBR_FULL" or "YBR_FULL_422"
- pixel representation (attribute 0028, 0103) = 0
- bits allocated (attribute 0028, 0100) = 8
- bits stored (attribute 0028,0101) = 8
- high bit (attribute 0028,0102) = 7

If Somaris/5 software is making any persistent changes on a YBR image, the resulting new image will be saved with Photometric Interpretation "RGB".

**Presentation Context
Acceptance Criterion -
Storage SCP**

The Somaris/5 DICOM application will accept any number of Verification or storage SOP classes that are listed above. The number of presentation contexts accepted is limited to the maximum of 127 (DICOM limit). In case the Siemens Somaris/5 DICOM application runs out of resources, it will reject the association request.

Transfer Syntax Selection Policies - Storage SCP

The Somaris/5 DICOM application supports

- ⇒ the Implicit VR Little Endian, the Explicit VR Little Endian and Explicit VR Big Endian transfer syntaxes
- ⇒ the JPEG Baseline and JPEG Extended transfer syntaxes (JPEG lossy)
- ⇒ the JPEG lossless Non-Hierarchical transfer syntax
- ⇒ the RLE Lossless Transfer Syntax
- ⇒ the JPEG 2000 Lossless and Lossy Transfer Syntax

Any proposed presentation context which includes one of these transfer syntaxes will be accepted. Any proposed presentation context that does not include one of these transfer syntaxes will be rejected.

The order of preference in accepting Transfer Syntaxes within Presentation Contexts or Presentation Contexts with single Transfer Syntaxes is:

1. JPEG Lossy Extended
2. JPEG Lossless Non-hierarchical
3. JPEG Lossy Baseline
4. RLE Lossless
5. Explicit VR Little Endian
6. Explicit VR Big Endian
7. Implicit VR Little Endian
8. JPEG 2000 Lossy
9. JPEG 2000 Lossless

With RLE Lossless Transfer Syntax the Somaris/5 application will decompress the image before storing it to the database.

With Implicit VR Little Endian Transfer Syntax the Somaris/5 DICOM application will remove any private attributes not known to the application. Decision on removal of a Private Element is done if there is NO entry in the attribute dictionary of the Somaris/5 DICOM application.

Thus any Explicit VR Transfer Syntax shall preferably be used by the Storage SCUs when sending Composite Image Instances to the Somaris/5 application.

Storage Commitment AE Specification

The Somaris/5 DICOM application provides Standard Conformance to the following DICOM V3.0 SOP Classes as SCU.

SOP Class Name	SOP Class UID
Storage Commitment Push Model	1.2.840.10008.1.20.1

Association Establishment Policies

General

With a Send Job successfully completed, the DICOM application will generate a Storage Commitment Identifier which references all instances of the processed job. The Commit Request is then sent over a single opened association. Somaris/5 will wait for Status responses of the Storage Commitment Request. If the Provider accepts the Storage Commitment with Success Status, the generated Transaction UID, together with study identification data and time stamp, is kept. Depending on configuration, the association is closed when the configured time out has elapsed or a response was received before. If the association is closed before a response was received, the response is then expected on a different association. Multiple Storage Commitment Requests can be pending.

The default PDU size will be 28 KB.

Number of Associations

The Somaris/5 DICOM application initiates several association at a time, one for each destination to which a transfer request is being processed in the active job queue list.



The Somaris/5 DICOM application is able to accept multiple association at a time. It can handle up to 10 associations in parallel.

Asynchronous Nature

The Somaris/5 DICOM application does not support asynchronous communication (multiple outstanding transactions over a single association).

Implementation Identifying Information

The Somaris/5 DICOM application provides the Implementation Class UID of

❑ "1.3.12.2.1107.5.1.4"

and an Implementation Version Name of

❑ "SIEMENS_S5VB41A".

Association Initiation Policy

The Somaris/5 Storage Commitment Application Entity acts as a SCU for the

- ❑ Storage Commitment Push Model Service Class (to request commitment for storage of instances previously sent)

To do so, Somaris/5 will issue a

- ❑ N-ACTION DIMSE to request commitment or a
- ❑ N-EVENT-REPORT DIMSE to respond to a received storage commitment request and the association was closed by the remote system prior to response.

Real-World Activity - Send Storage Commitment Request

Associated Real-World Activity - Job Completed

The Somaris/5 Storage Commitment application sends the commit request (N-ACTION_RQ) message and waits for acceptance of this request (N_ACTION-RSP). After receiving this, the transaction is marked as "waiting".

Depending on a configuration value, the association will then be closed or kept open. In the first case there is another configurable timeout giving the number of hours (h) and minutes (m) (by default 1h:0m) to wait for the corresponding commit response (N_EVENT-REPORT). In the second case, this time is the (also configurable) time out for the association. For both cases, if the commit response (N-EVENT-REPORT) does not arrive during the configured time, the transaction will be marked as failed. Somaris/5 does not re-send objects because of a failed Storage Commitment result in any case.

If the commit response (N-EVENT-REPORT) received has the status of "complete - failure exists", the transaction is marked as failed, else the transaction is marked as "completed"; in both cases, a message is shown to the user.

Proposed Presentation Contexts - Job Completed

The Somaris/5 Storage Commitment AE will propose Presentation Contexts as shown in the following table:

Presentation Context Table					
Abstract Syntax		Transfer Syntax		Role	Extended
Name	UID	Name List	UID List		Negotiation
Storage Commitment Push Model	1.2.840.10008.1.20.1	Implicit VR Little Endian	1.2.840.10008.1.2	SCU	None
		Explicit VR Little Endian	1.2.840.10008.1.2.1		
		Explicit VR Big Endian	1.2.840.10008.1.2.2		

SOP Specific Conformance Statement - Job Completed

Storage Commitment is supported for all the SOP class UIDs as mentioned in table → page A.2–18.

The Referenced Study Component Sequence is not supported.

Storage Media File-Set ID and UID Attributes will not be supported in the commitment request (N-ACTION primitive) invoked by the Storage Commitment SCU.

Association Acceptance Policy

The Somaris/5 Storage Commitment AE accepts an association in this case: when acting as SCU if configured to receive N-EVENT-REPORT on a separate association.

Real World Activity - Receive Storage Commitment Response

Associated Real World Activity - Update Flags

The Somaris/5 Storage Commitment AE has sent a Storage Commitment Request and, being configured to receive response on a separate association, has closed the association, and now it gets an association request from the Storage Commitment SCP that wants to send the results. The application will wait for Storage Commitment Notification triggers. Any incoming notification will be checked for validity, that is, if the related Transaction UID is still part of the Pending Request Queue.

If the Notification is valid, the Notification Identifier is evaluated and the related Instances marked with the related status. The over all Commit Status of the higher Information Entities is derived from propagation of all Image entities included in a study.

The status flags directly affected by Storage Commitment results and indicated in the different entities of the Patient Browser list can be one of (English UI assumed):

- "AC" or "SC" - Successful Commitment. A means archived to configured archive destination, whereas S means sent to any other destination.
- "Af" or "Sf" - Commitment failed
- "A?" or "S?" - Commitment request is sent, response is pending

In case of failure the user has to repeat the transfer of images to the Archive destination. Another Storage Commitment will be performed after sending is completed successfully.

Accepted Presentation Contexts - Update Flags

The Somaris/5 Storage Commitment AE will accept Presentation Contexts as shown in the following table:

Presentation Context Table					
Abstract Syntax		Transfer Syntax		Role	Extended
Name	UID	Name List	UID List		Negotiation
Storage Commitment Push Model SOP class	1.2.840.10008.1.20.1	Implicit VR Little Endian Explicit VR Little Endian Explicit VR Big Endian	1.2.840.10008.1.2 1.2.840.10008.1.2.1 1.2.840.10008.1.2.2	SCU	None

SOP Specific Conformance Statement - Receive Storage Commitment Response

If the Commitment Response (N_EVENT_REPORT) received has the status of "complete - failure exists", the transaction is marked as failed, else the transaction is marked as "completed"; In both cases, a message is shown to the user.

The related status flags are set for the committed images in the local database.

The Somaris/5 DICOM application will NOT support the Storage Media File Set ID attributes.

Query/Retrieve AE Specification

The Query/Retrieve SCU requests that the remote SCP performs a match of all keys specified in the request against the information in its database and the identified images will be moved over a different (C-MOVE) storage association.

The Query/Retrieve SCP responds to queries of the records based on its database and images will be sent to the requesting SCU or to a different storage destination.

The Somaris/5 DICOM application provides Standard Conformance to the following DICOM V3.0 SOP Classes as SCU and SCP:

SOP Class Name	SOP Class UID
Patient Root Query/Retrieve Information Model - FIND	1.2.840.10008.5.1.4.1.2.1.1
Patient Root Query/Retrieve Information Model - MOVE	1.2.840.10008.5.1.4.1.2.1.2
Study Root Query/Retrieve Information Model - FIND	1.2.840.10008.5.1.4.1.2.2.1
Study Root Query/Retrieve Information Model - MOVE	1.2.840.10008.5.1.4.1.2.2.2
Patient/Study Only Query/Retrieve Information Model - FIND	1.2.840.10008.5.1.4.1.2.3.1
Patient/Study Only Query/Retrieve Information Model - MOVE	1.2.840.10008.5.1.4.1.2.3.2

Somaris/5 DICOM implementation provides Standard Conformance to the following DICOM V3.0 SOP Classes as an SCP:

SOP Class Name	SOP Class UID
Patient Root Query/Retrieve Information Model - FIND	1.2.840.10008.5.1.4.1.2.1.1
Patient Root Query/Retrieve Information Model - MOVE	1.2.840.10008.5.1.4.1.2.1.2
Patient Root Query/Retrieve Information Model - GET	1.2.840.10008.5.1.4.1.2.1.3
Study Root Query/Retrieve Information Model - FIND	1.2.840.10008.5.1.4.1.2.2.1
Study Root Query/Retrieve Information Model - MOVE	1.2.840.10008.5.1.4.1.2.2.2
Study Root Query/Retrieve Information Model - GET	1.2.840.10008.5.1.4.1.2.2.3
Patient/Study Only Query/Retrieve Information Model - FIND	1.2.840.10008.5.1.4.1.2.3.1
Patient/Study Only Query/Retrieve Information Model - MOVE	1.2.840.10008.5.1.4.1.2.3.2
Patient/Study Only Query/Retrieve Information Model - GET	1.2.840.10008.5.1.4.1.2.3.3

Note

See also the Storage DICOM Conformance Statement (→ page A.2–17, *Association Acceptance Policy*) to compare for conformance of the C-STORE sub-operation generated by the C-MOVE and C-GET DIMSE services. Furthermore compare the supported Storage Service SOP classes described in the Storage DICOM Conformance Statement of the Modality to which the images shall be transferred to.

Association Establishment Policies

General

With the "Search..." function the query data are entered and the DICOM Query/Retrieve application is started. A query request will be sent out to one remote node that can be selected from a list of configured Query Providers and the response data will be displayed for the user. In order to provide detailed information early additional queries are sent for the more detailed levels not yet covered by the first results. Upon request (Import), the retrieval of selected items is initiated.

The default PDU size used will be 28 KB.

Number of Associations

The Somaris/5 DICOM Query/Retrieve application initiates several association at a time, one for each query/retrieve request being processed.

The Somaris/5 DICOM Query/Retrieve application is able to accept multiple associations at a time. It can handle up to 10 associations in parallel.

Asynchronous Nature

The Somaris/5 DICOM Query/Retrieve application does not support asynchronous communication (multiple outstanding transactions over a single association).

Implementation Identifying Information

The Somaris/5 DICOM Query/Retrieve AE provides the Implementation Class UID of

❑ "1.3.12.2.1107.5.1.4"

and an Implementation Version Name of

❑ "SIEMENS_S5VB41A".



Association Initiation Policy

The Query/Retrieve user interface will request the query data from the user and triggers C-FIND requests to the selected remote node. The response data will be displayed in the query UI for further data navigation.

When requesting Import of related items the browser requests the retrieve application to send a C_MOVE request to the related remote node. Images will then be received by the Storage SCP as described in the related section.

The following DIMSE-C operations are supported as SCU:

- C-FIND
- C-MOVE

Real-World Activity - Find SCU

Associated Real-World Activity - Find SCU "Search"

The associated Real-World activity is to fill out a query form with search data and pass it as queries to the network application which issues a C-FIND over a previously built association. The remote SCP will respond with related data entries that will be passed to a browser application. When data transfer is finished the association is closed.

Proposed Presentation Contexts - Find SCU

The Somaris/5 DICOM Query application will propose Presentation Contexts as shown in the following table:

Presentation Context Table

Abstract Syntax		Transfer Syntax		Role	Extended Negotiation
Name	UID	Name List	UID List		
Patient Root Query/Retrieve Model - FIND	1.2.840.10008.5.1.4.1.2.1.1	DICOM Implicit VR Little Endian Transfer Syntax	1.2.840.10008.1.2	SCU	See Note
		DICOM Explicit VR Little Endian Transfer Syntax	1.2.840.10008.1.2.1		
		DICOM Explicit VR Big Endian Transfer Syntax	1.2.840.10008.1.2.2		



Study Root Query/Retrieve Model - FIND	1.2.840.10008.5.1.4.1.2.2.1	DICOM Implicit VR Little	1.2.840.10008.1.2	SCU	See Note
		Endian Transfer Syntax			
		DICOM Explicit VR Little	1.2.840.10008.1.2.1		
		Endian Transfer Syntax			
Patient Study only Query/ Retrieve Model - FIND	1.2.840.10008.5.1.4.1.2.3.1	DICOM Implicit VR Little	1.2.840.10008.1.2	SCU	See Note
		Endian Transfer Syntax			
		DICOM Explicit VR Little	1.2.840.10008.1.2.1		
		Endian Transfer Syntax			
		DICOM Explicit VR Big	1.2.840.10008.1.2.2		
		Endian Transfer Syntax			

It is configurable which of the three query models are to be used by the Somaris/5 Query SCU application. If Patient and Study Root Abstract Syntaxes are configured, the C_FIND SCU will use the Patient Root Model only for C-FIND requests on PATIENT level. For all other levels it will use the STUDY Root Model.

It is highly recommended to configure only the Study Root Model if the corresponding Query SCP supports this Model. If the Query SCP does not support queries on Series Level, Patient Study Only Model should be used.

SOP Specific Conformance Statement - Find SCU

The Somaris/5 DICOM Query/Retrieve SCU supports hierarchical queries with all mandatory search keys. On each level, the unique attributes of all previous levels are also sent (values are provided by the user by selection from a list). For instance for a query using the patient root model on Series level, the Patient ID of the current selected patient and the Study Instance UID of the current selected study are included in the message. The interactive querying of attributes on IMAGE level is not supported by the Query SCU. Nevertheless, retrieval of individual Objects is possible.

The Query dialog in Somaris/5 offers search keys on different levels (Patient, Study, Series). Depending on the used Query Model (Patient Root, Study Root, Patient Study Only) the Somaris/5 DICOM Query/Retrieve SCU will execute multiple queries sequentially.

E.g. Patient Root Model:

The first query is performed on patient level with the entered patient level query keys. For each query result a new query is performed on study level with the entered study level query keys. At last for each result on study level a query is performed on series level with the entered series level keys.

The following table *Query attributes* describes the search keys for the three query models (Patient Root, Study Root and Patient Study Only) that the Somaris/5 Query/Retrieve application supports as an SCU. Matchings are either wildcard, which means that the user can supply a string containing wildcards, either universal, or means that the attribute is returned no matter what value it has.



Attribute name	Tag	Type	Matching	User input	Return value displayed
Patient level^a					
Patient name	(0010,0010)	R	wildcard ^d	enter value	yes
Patient ID	(0010,0020)	U	wildcard ^d	enter value	yes
Patient's birth date	(0010,0030)	O	universal (NULL)	enter value	yes
Patient's sex	(0010,0040)	O	universal (NULL)	enter value	yes
Number of Patient related studies	(0020,1200)	O	universal (NULL)	-	yes ^b
Number of Patient relates series	(0020,1202)	O	universal (NULL)	-	no
Number of Patient related instances	(0020,1204)	O	universal (NULL)	-	no
Study level					
Patient name ^c	(0010,0010)	R	wildcard ^d	enter value	yes
Patient ID	(0010,0020)	R	wildcard ^d	enter value	yes
Patient's birth date ^c	(0010,0030)	O	universal (NULL)	enter value	yes
Patient's sex ^c	(0010,0040)	O	universal (NULL)	enter value	yes
Study Instance UID	(0020,000D)	U	single value	-	yes
Study ID	(0020,0010)	R	universal (NULL)	enter value ^d	yes
Study date	(0008,0020)	R	universal (NULL)	enter value ^e	yes

Attribute name	Tag	Type	Matching	User input	Return value displayed
Study time	(0008,0030)	R	universal (NULL)	-	yes
Accession number	(0008,0050)	R	universal (NULL)	enter value ^d	yes
Study description	(0008,1030)	O	universal (NULL)	enter value ^d	yes
Referring physician's name	(0008,0090)	O	universal (NULL)	enter value ^d	yes
Name of physician reading study	(0008,1060)	O	universal (NULL)	enter value ^d	yes
Modalities in Study	(0008,0061)	O	universal (NULL)	enter value ^d	yes
Storage Media File Set ID	(0008,0130)	O	universal (NULL)	-	no
Retrieve AE Title	(0008,0054)	O	universal (NULL)	-	no
Number of study related series	(0020,1206)	O	universal (NULL)	-	yes ^f
Number of study related instances	(0020,1208)	O	universal (NULL)	-	no
Series level					
Series instance UID	(0020,000E)	U	single value	-	yes
Series number	(0020,0011)	R	universal (NULL)	-	yes
Modality	(0008,0060)	R	universal (NULL)	enter value	yes

Attribute name	Tag	Type	Matching	User input	Return value displayed
Series date	(0008,0021)	O	universal (NULL)	-	yes
Series time	(0008,0031)	O	universal (NULL)	-	yes
Study ID	(0020,0010)	O	universal (NULL)	-	yes
Series description	(0008,103E)	O	universal (NULL)	enter value ^d	yes
Storage Media File Set ID	(0008,0130)	O	universal (NULL)	-	yes
Retrieve AE Title	(0008,0054)	O	universal (NULL)	-	yes
Body Part Examined	(0018,0015)	O	universal (NULL)	enter value ^d	yes
Protocol name	(0018,1030)	O	universal (NULL)	-	no
Performing Physician	(0018,1050)	O	universal (NULL)	enter value ^d	yes
Performed procedure step start date	(0040,0244)	O	universal (NULL)	-	yes
Performed procedure step start time	(0040,0245)	O	universal (NULL)	-	yes
Request Attribute Sequence	(0040,0275)	O	universal (NULL)	-	yes
> Requested Procedure ID	(0040,1001)	O	universal (NULL)	-	yes
> Scheduled Procedure ID	(0040,0009)	O	universal (NULL)	-	yes

Attribute name	Tag	Type	Matching	User input	Return value displayed
Number of series related instances	(0020,1209)	O	universal (NULL)	-	yes
Image Level					
SOP Instance UID	(0008,0018)	U	single value	-	no
Instance Number	(0020,0013)	R	universal (NULL)	-	yes
Storage Media File Set ID	(0008,0130)	O	universal (NULL)	-	no
Retrieve AE Title	(0008,0054)	O	universal (NULL)	-	no
Content date	(0008,0023)	O	universal (NULL)	-	no
Content time	(0008,0033)	O	universal (NULL)	-	no
Number of Frames	(0028,0008)	O	universal (NULL)	-	yes
Image comments	(0020,4000)	O	universal (NULL)	-	no
Referenced Request	(0040,A370)	O	sequence matching	-	yes
> Accession Number	(0008,0050)	O	single value, universal	-	yes
> Requested Procedure ID	(0040,1000)	O	single value, universal	-	yes



Attribute name	Tag	Type	Matching	User input	Return value displayed
Concept Name Code Sequence	(0040,A043)	O	single value, universal	-	yes
> Code Value	(0008,0100)	O	single value, universal	-	yes
> Coding Scheme Designator	(0008,0102)	O	single value, universal	-	yes
> Coding Scheme Version	(0008,0103)	O	single value, universal	-	yes
> Code Meaning	(0008,0104)	O	single value, universal	-	yes
Template Identifier	(0040,DB00)	O	single value, universal	-	yes
Completion Flag	(0040,A491)	O	single value, universal	entervalue	yes
Verification Flag	(0040,A493)	O	single value, universal	entervalue	yes
Verifying Observer Sequence	(0040,A073)	O	sequence matching	entervalue	yes
> Verifying Oragnization	(0080,A072)	O	single value, universal	-	



Attribute name	Tag	Type	Matching	User input	Return value displayed
> Verifying Date Time	(0008,A030)	O	single value, universal	entervalue	yes
> Verifying Observer Name	(0080,A075)	O	single value, universal	entervalue	yes
> Verifying Observer Identification Code Sequence	(0040,A088)	O	single value, universal		yes
>> Code Value	(0008,0100)	O	single value, universal	-	yes
>> Coding Scheme Designator	(0008,0102)	O	single value, universal	-	yes
>> Coding Scheme Version	(0008,0103)	O	single value, universal	-	yes
>> Code Meaning	(0008,0104)	O	single value, universal	-	yes

- a. Only for Patient Root or Patient Study Only information model
- b. Implicitly visualized in the UI if no study and series search attributes have been entered
- c. Only for Study Root information model
- d. Always a "*" is added to the string supplied by the user
- e. Date range possible
- f. Implicitly visualized in the UI if no series search attributes have been entered

The Find SCU interprets following status codes:

C-FIND response status			
Service Status	Meaning	Protocol Codes	Related Fields
Refused	Out of Resources	A700	(0000,0902)
Failed	Identifier does not match SOP Class	A900	(0000,0901) (0000,0902)
	Unable to process	Cxxx	(0000,0901) (0000,0902)
Cancel	Matching terminated due to Cancel request	FE00	None
Success	Matching is complete - No final Identifier is supplied	0000	None
Pending	Matches are continuing – Current Match is supplied and any Optional Keys were supported in the same manner as Required Keys	FF00	Identifier
	Matches are continuing – Warning that one or more Optional Keys were not supported for existence and/or matching for this identifier	FF01	Identifier

Associated Real-World Activity - Move SCU "Import"

Real-World Activity - Move SCU

The operator selects a data entry in the Query UI and activates the "Import" function.

This will generate a retrieval request to the archival application which issues a C-MOVE service according to the Patient Root or Study Root query model. (The Storage Service Class Conformance Statement of the SCP describes the C-STORE service which is generated by processing the C-MOVE service.)

The transferred image data are processed as described in the storage class SCP descriptions.

The possibility to request the remote C-MOVE provider to move data to an application entity other than the C-MOVE SCU (the Somaris/5 DICOM application) is NOT used.

Proposed Presentation Contexts - Move SCU "Import"

The Somaris/5 DICOM application will propose Presentation Contexts as shown in the following table:

Presentation Context Table

Name	Abstract Syntax		Transfer Syntax		Role	Extended Negotiation
	UID		Name List	UID List		
Patient Root Query/Retrieve Model - MOVE	1.2.840.10008.5.1.4.1.2.1.2	DICOM Implicit VR Little Endian Transfer Syntax	1.2.840.10008.1.2	SCU	See Note	
		DICOM Explicit VR Little Endian Transfer Syntax	1.2.840.10008.1.2.1			
		DICOM Explicit VR Big Endian Transfer Syntax	1.2.840.10008.1.2.2			
Study Root Query/Retrieve Model - MOVE	1.2.840.10008.5.1.4.1.2.2.2	DICOM Implicit VR Little Endian Transfer Syntax	1.2.840.10008.1.2	SCU	See Note	
		DICOM Explicit VR Little Endian Transfer Syntax	1.2.840.10008.1.2.1			
		DICOM Explicit VR Big Endian Transfer Syntax	1.2.840.10008.1.2.2			



Patient Study Only Query/Retrieve Model - MOVE	1.2.840.10008.5.1.4.1.2.3.2	DICOM Implicit VR Little Endian Transfer Syntax	1.2.840.10008.1.2	SCU	See Note
		DICOM Explicit VR Little Endian Transfer Syntax	1.2.840.10008.1.2.1		
		DICOM Explicit VR Big Endian Transfer Syntax	1.2.840.10008.1.2.2		

Note

C-MOVE Extended Negotiation will be NOT supported by the SCU.

C-MOVE on Patient level is not supported by the application.

SOP Specific Conformance Statement - Move SCU "Import"

At association establishment time the C-MOVE presentation context shall be negotiated. The C-STORE sub-operations must be done on a different association to transfer images to the own Storage Service Class SCP.

The Move SCU interprets following status codes:

C-MOVE response status			
Service Status	Meaning	Protocol Codes	Related Fields
Refused	Out of Resources - Unable to calculate number of matches	A701	(0000,0902)
	Out of Resources - Unable to perform suboperations	A702	(0000,1020) (0000,1021) (0000,1022) (0000,1023)
Failed	Identifier does not match SOP Class	A900	(0000,0901) (0000,0902)
Failed	Unable to process	Cxxx	(0000,0901) (0000,0902)
Cancel	Sub-operations terminated due to Cancel Indication	FE00	(0000,1020) (0000,1021) (0000,1022) (0000,1023)
Warning	Sub-operations Complete - One or more Failures of Warnings	B000	(0000,1020) (0000,1021) (0000,1022) (0000,1023)
Pending	Sub-operations are continuing	FF00	(0000,1020) (0000,1021) (0000,1022) (0000,1023)



C-MOVE response status			
Service Status	Meaning	Protocol Codes	Related Fields
Success	Sub-operations Complete - No Failures or Warning	0000	(0000,1020) (0000,1021) (0000,1022) (0000,1023)

Association Acceptance Policy

The Query/Retrieve SCU and SCP establish an association by using the DICOM association services. During association establishment the Query/Retrieve application entities negotiate the supported SOP classes to exchange the capabilities of the SCU and the SCP.

The following DIMSE-C operations are supported as SCP:

- C-FIND
- C-GET
- C-MOVE
- C-FIND-CANCEL
- C-GET-CANCEL
- C-MOVE-CANCEL

Real-World Activity - Find SCP

Associated Real-World Activity - Find SCP

The associated Real-World activity is to respond to query requests to an SCU with the query model Patient Root, Study Root and Patient/Study Only. Relational retrieve operation is NOT supported. With a C-FIND-CANCEL request the running query can be cancelled at any time.

The SCP does support multiple C-FIND-requests over the same association, but not multiple C-MOVE requests.

Accepted Presentation Contexts - Find SCP

The Somaris/5 Query/Retrieve AE will accept Presentation Contexts as shown in the following table:

Presentation Context Table

Abstract Syntax		Transfer Syntax		Role	Extended Negotiation
Name	UID	Name List	UID List		
Patient Root Query/Retrieve Model - FIND	1.2.840.10008.5.1.4.1.2.1.1	Implicit VR Little Endian	1.2.840.10008.1.2	SCP	See Note
		Explicit VR Little Endian	1.2.840.10008.1.2.1		
		Explicit VR Big Endian	1.2.840.10008.1.2.2		
Study Root Query/Retrieve Model - FIND	1.2.840.10008.5.1.4.1.2.2.1	Implicit VR Little Endian	1.2.840.10008.1.2	SCP	See Note
		Explicit VR Little Endian	1.2.840.10008.1.2.1		
		Explicit VR Big Endian	1.2.840.10008.1.2.2		
Patient/Study Only Query/ Retrieve Model - FIND	1.2.840.10008.5.1.4.1.2.3.1	Implicit VR Little Endian	1.2.840.10008.1.2	SCP	See Note
		Explicit VR Little Endian	1.2.840.10008.1.2.1		
		Explicit VR Big Endian	1.2.840.10008.1.2.2		

Note

C-FIND Extended Negotiation will NOT be supported by the SCP.

The order of preference in accepting a Transfer syntax is:

1. Explicit VR Little Endian
2. Explicit VR Big Endian
3. Implicit VR Little Endian

SOP Specific Conformance Statement - Find SCP

The Somaris/5 DICOM Query/Retrieve SCP supports hierarchical queries with all mandatory and optional search keys.

The following six notes apply to the handling of attribute Patient's Name (0010,0010) as Query/Retrieve SCP. The syntactical structure of Patient's Name (0010,0010) attribute is as follows:

<single byte group>=<ideographic group>=<phonetic group>

Each group may have up to five components, which are separated by carets "^".

- ❑ 1. Matching of Patient's Name attribute (0010,0010) is done case-insensitive.
- ❑ 2. If a search string matches the complete value of a data base object's Patient's Name, a match will be returned.
- ❑ 3. If a search string matches an individual group (single byte, ideographic or phonetic) of a data base object's Patient's Name, a match will be returned.
- ❑ 4. If a search string matches two consecutive groups of a data base object's Patient's Name, a match will be returned.
- ❑ 5. Redundant group separators "=" or component separators "^" are treated as insignificant for matching.
- ❑ 6. Leading and trailing blanks within a component or a group of Patient's Name (0010,0010) are treated as insignificant for matching.

Except for the attribute Patient's Name (0010,0010) any other query attribute contents will be treated Case Sensitive.

With wildcard queries the symbol "?" is treated as "*" by the C-FIND-SCP application. As a consequence the query string of "?abc*" will be processed as "*abc*".

If the value for the patient level unique key "Patient ID" is not known, it may be returned with zero length. The attribute "Image Comments" will not be included in the C-FIND-RSP, if it is not set in the DB, even if it was requested as return key in the related C-FIND-RQ.

Usage of Storage Media File Set ID, Retrieve AE Title with C-FIND-RSP message:

- ❑ The C-FIND SCP may return the DICOM attributes StorageMediaFileSetID (0088,0130) and StorageMediaFileSetUID (0088,0140) as empty or not at all. The Storage Media File Set ID - if existent - can be returned at Study/Series/Image Level. Only on Image Level, the values of ONLINE, NEARLINE or OFFLINE are returned to indicate the Storage Location of the related instance.
- ❑ The C-FIND SCP may return the DICOM attributes Retrieve AE Title (0008,0054) as empty or not at all. The Retrieve AE Title - if existent - can only be returned at Image Level (for Patient Root and Study Root models) or Study Level (for Patient/Study Only model).

Relational Queries are NOT supported.

A remote DICOM AE can cancel the running query by sending a C-FIND-CANCEL. Matches are possibly continuing (more C-FIND response with status PENDING) until the cancel operation has completed.

The supported attributes on the various levels of the three information models are listed in the tables of the following sections.

Patient Root Information Model

Patient level attributes, Patient Root Information Model			
Attribute name	Tag	Type	Matching
Patient name	(0010,0010)	R	single value, wildcard, universal
Patient id	(0010,0020)	U	single value, wildcard, universal
Patient's birth date	(0010,0030)	O	single value, range, universal
Patient's birth time	(0010,0032)	O	single value, range, universal
Patient's sex	(0010,0040)	O	single value, wildcard, universal
Ethnic group	(0010,2160)	O	single value, wildcard, universal
Patient comments	(0010,4000)	O	wildcard, universal
Number of Patient related studies	(0020,1200)	O	universal
Number of Patient relates series	(0020,1202)	O	universal
Number of Patient related instances	(0020,1204)	O	universal

Study level attributes, Patient Root Information Model			
Attribute name	Tag	Usage SCU	Matching
Study instance UID	(0020,000D)	U	single value, list of UID
Study id	(0020,0010)	R	single value, wildcard, universal

Study level attributes, Patient Root Information Model

Attribute name	Tag	Usage SCU	Matching
Study date	(0008,0020)	R	single value, range, universal
Study time	(0008,0030)	R	single value, range, universal
Accession number	(0008,0050)	R	single value, wildcard, universal
Referring physician's name	(0008,0090)	O	single value, wildcard, universal
Study description	(0008,1030)	O	single value, wildcard, universal
Admitting diagnoses description	(0008,1080)	O	single value, wildcard, universal
Patient's age	(0010,1010)	O	single value, wildcard, universal
Patient's size	(0010,1020)	O	single value, universal
Patient's weight	(0010,1030)	O	single value, universal
Additional patient history	(0010,21B0)	O	wildcard, universal
Name of physician reading study	(0008,1060)	O	single value, wildcard, universal
Modalities in Study	(0008,0061)	O	multiple values, universal
Number of study related series	(0020,1206)	O	universal
Number of study related instances	(0020,1208)	O	universal

Series level attributes, Patient Root Information Model

Attribute name	Tag	Usage SCU	Matching
Series instance UID	(0020,000E)	U	single value, list of UID
Series number	(0020,0011)	R	single value, universal
Modality	(0008,0060)	R	single value, wildcard, universal
Laterality	(0020,0060)	O	single value, wildcard, universal
Body part examined	(0018,0015)	O	single value, wildcard, universal
Patient position	(0018,5100)	O	single value, wildcard, universal
Smallest pixel value in series	(0028,0108)	O	single value, universal
Largest pixel value in series	(0028,0109)	O	single value, universal
Protocol name	(0018,1030)	O	single value, wildcard, universal
Series date	(0008,0021)	O	single value, range, universal
Series time	(0008,0031)	O	single value, range, universal
Series description	(0008,103E)	O	single value, wildcard, universal
Operators name	(0008,1070)	O	single value, wildcard, universal
Performing physician's name	(0008,1050)	O	single value, wildcard, universal

Series level attributes, Patient Root Information Model

Attribute name	Tag	Usage SCU	Matching
Performed procedure step start date	(0040,0244)	O	universal
Performed procedure step start time	(0040,0245)	O	universal
Number of series related instances	(0020,1209)	O	universal
Referenced request sequence	(0040,A370)	O	sequence matching

Image level attributes, Patient Root Information Model

Attribute name	Tag	Usage SCU	Matching
SOP instance UID	(0008,0018)	U	single value, list of UID
Instance number	(0020,0013)	R	single value, universal
Content date	(0008,0023)	O	single value, range, universal
Content time	(0008,0033)	O	single value, range, universal
Modality	(0008,0060)	O	single value, wildcard, universal
Image comments	(0020,4000)	O	universal
Referenced Request Sequence	(0040,A370)	O	sequence matching
> Accession Number	(0008,0050)	O	single value, universal
> Requested Procedure ID	(0040,1000)	O	single value, universal

Image level attributes, Patient Root Information Model

Attribute name	Tag	Usage SCU	Matching
Concept Name Code Sequence	(0040,A043)	0	sequence matching
> Code Value	(0080,0100)	0	single value, universal, wildcard
> Coding Scheme Designator	(0008,0102)	0	single value, universal, wildcard
> Coding Scheme Version	(0008,0103)	0	single value, universal, wildcard
> Code Meaning	(0008,0104)	0	single value, universal, wildcard
Template Identifier	(0040,DB00)	0	single value, universal, wildcard
Completion Flag	(0040,A491)	0	single value, universal, wildcard
Verification Flag	(0040,A493)	0	single value, universal, wildcard
Verifying Observer Sequence	(0040,A473)	0	sequence matching
> Verifying Organization	(0040,A072)	0	single value, universal, wildcard
> Verifying Date Time	(0008,A030)	0	single value, range matching, universal,
> Verifying Observer Name	(0008,A075)	0	single value, universal, wildcard
> Verifying Observer Identification Code Sequence	(0040,A088)	0	sequence matching
>> Code Value	(0008,0100)	0	single value, universal, wildcard



Image level attributes, Patient Root Information Model			
Attribute name	Tag	Usage SCU	Matching
>> Coding Scheme Designator	(0008,0102)	0	single value, universal, wildcard
>> Coding Scheme Version	(0008,0103)	0	single value, universal, wildcard
>> Code Meaning	(0008,0104)	0	single value, universal, wildcard

Study Root Information Model

Study level attributes, Study Root Information Model			
Attribute name	Tag	Type	Matching
Patient name	(0010,0010)	R	single value, wildcard, universal
Patient id	(0010,0020)	R	single value, wildcard, universal
Patient's birth date	(0010,0030)	O	single value, range, universal
Patient's birth time	(0010,0032)	O	single value, range, universal
Patient's sex	(0010,0040)	O	single value, wildcard, universal
Patient comments	(0010,4000)	O	wildcard, universal
Number of Patient related studies	(0020,1200)	O	universal
Number of Patient relates series	(0020,1202)	O	universal
Number of Patient related instances	(0020,1204)	O	universal
Study instance UID	(0020,000D)	U	single value, list of UIDs
Study id	(0020,0010)	R	single value, wildcard, universal
Study date	(0008,0020)	R	single value, range, universal
Study time	(0008,0030)	R	single value, range, universal
Accession number	(0008,0050)	R	single value, wildcard, universal



Study level attributes, Study Root Information Model			
Attribute name	Tag	Type	Matching
Referring physician's name	(0008,0090)	0	single value, wildcard, universal
Study description	(0008,1030)	0	single value, wildcard, universal
Admitting diagnoses description	(0008,1080)	0	single value, wildcard, universal
Patient's age	(0010,1010)	0	single value, wildcard, universal
Patient's size	(0010,1020)	0	single value, universal
Patient's weight	(0010,1030)	0	single value, universal
Occupation	(0010,2180)	0	single value, wildcard, universal
Additional patient history	(0010,21B0)	0	wildcard, universal
Name of physician reading study	(0008,1060)	0	single value, wildcard, universal
Modalities in Study	(0008,0061)	0	multiple values, universal
Number of study related series	(0020,1206)	0	universal
Number of study related instances	(0020,1208)	0	universal

Series level attributes, Study Root Information Model

Attribute name	Tag	Type	Matching
Series instance UID	(0020,000E)	U	single value, list of UID
Series number	(0020,0011)	R	single value, universal
Modality	(0008,0060)	R	single value, wildcard, universal
Laterality	(0020,0060)	O	single value, wildcard, universal
Body part examined	(0018,0015)	O	single value, wildcard, universal
Patient position	(0018,5100)	O	single value, wildcard, universal
Smallest pixel value in series	(0028,0108)	O	single value, universal
Largest pixel value in series	(0028,0109)	O	single value, universal
Protocol name	(0018,1030)	O	single value, wildcard, universal
Series date	(0008,0021)	O	single value, range, universal
Series time	(0008,0031)	O	single value, range, universal
Series description	(0008,103E)	O	single value, wildcard, universal
Operators name	(0008,1070)	O	single value, wildcard, universal
Performing physician's name	(0008,1050)	O	single value, wildcard, universal

Series level attributes, Study Root Information Model

Attribute name	Tag	Type	Matching
Performed procedure step start date	(0040,0244)	O	universal
Performed procedure step start time	(0040,0245)	O	universal
Number of series related instances	(0020,1209)	O	universal

Image level attributes, Study Root Information Model

Attribute name	Tag	Type	Matching
SOP instance UID	(0008,0018)	U	single value, list of UID
Instance number	(0020,0013)	R	single value, universal
Content date	(0008,0023)	O	single value, range, universal
Content time	(0008,0033)	O	single value, range, universal
Modality	(0008,0060)	O	single value, wildcard, universal
Image comments	(0020,4000)	O	universal
Referenced Request Sequence	(0040,A370)	O	sequence matching
> Accession Number	(0008,0050)	O	single value, universal
> Requested Procedure ID	(0040,1000)	O	single value, universal
Concept Name Code Sequence	(0040,A043)	O	sequence matching

Image level attributes, Study Root Information Model

Attribute name	Tag	Type	Matching
> Code Value	(0008,0100)	0	single value, universal, wildcard
> Code Scheme Designator	(0008,0102)	0	single value, universal, wildcard
> Code Scheme Version	(0008,0103)	0	single value, universal, wildcard
> Code Meaning	(0008,0104)	0	single value, universal, wildcard
Template Identifier	(0040,DB00)	0	single value, universal, wildcard
Completion Flag	(0040,A491)	0	single value, universal, wildcard
Verification Flag	(0040,A493)	0	single value, universal, wildcard
Verifying Observer Sequence	(0040,A073)	0	sequence matching
> Verifying Organization	(0008,A072)	0	single value, universal, wildcard
> Verifying Date Time	(0008,A030)	0	single value, range matching, universal
> Verifying Observer Name	(0008,A075)	0	single value, universal, wildcard
> Verifying Observer Identification Code Sequence	(0040,A088)	0	sequence matching
>> Code Value	(0008,0100)	0	single value, universal, wildcard
>> Coding Scheme Designator	(0008,0102)	0	single value, universal, wildcard



Image level attributes, Study Root Information Model			
Attribute name	Tag	Type	Matching
>> Coding Scheme Version	(0008,0103)	O	single value, universal, wildcard
>> Code Meaning	(0008,0104)	O	single value, universal, wildcard

Patient Study Only Information Models

Patient instance level, Patient Study Only Information Model

Attribute name	Tag	Type	Matching
Patient name	(0010,0010)	R	single value, wildcard, universal
Patient id	(0010,0020)	U	single value, wildcard, universal
Patient's birth date	(0010,0030)	O	single value, range, universal
Patient's birth time	(0010,0032)	O	single value, range, universal
Patient's sex	(0010,0040)	O	single value, wildcard, universal
Ethnic group	(0010,2160)	O	single value, wildcard, universal
Patient comments	(0010,4000)	O	wildcard, universal
Number of Patient related studies	(0020,1200)	O	universal
Number of Patient relates series	(0020,1202)	O	universal
Number of Patient related instances	(0020,1204)	O	universal

Study level attributes, Patient Study Only Information Model

Attribute name	Tag	Type	Matching
Study instance UID	(0020,000D)	U	single value, list of UIDs
Study id	(0020,0010)	R	single value, wildcard, universal

Study level attributes, Patient Study Only Information Model

Attribute name	Tag	Type	Matching
Study date	(0008,0020)	R	single value, range, universal
Study time	(0008,0030)	R	single value, range, universal
Accession number	(0008,0050)	R	single value, wildcard, universal
Referring physician's name	(0008,0090)	O	single value, wildcard, universal
Study description	(0008,1030)	O	single value, wildcard, universal
Admitting diagnoses description	(0008,1080)	O	single value, wildcard, universal
Patient's age	(0010,1010)	O	single value, wildcard, universal
Patient's size	(0010,1020)	O	single value, universal
Patient's weight	(0010,1030)	O	single value, universal
Occupation	(0010,2180)	O	single value, wildcard, universal
Additional patient history	(0010,21B0)	O	wildcard, universal
Name of physician reading study	(0008,1060)	O	single value, wildcard, universal
Modalities in Study	(0008,0061)	O	multiple values, universal
Number of study related series	(0020,1206)	O	universal
Number of study related instances	(0020,1208)	O	universal

Note

The C-FIND-RSP message will contain the following attributes:

- Specific Character Set (0008,0005) (If there is a specific character set in use).
- Query/Retrieve Level (0008,0052) from the C_FIND_RQ.
- Retrieve AE Title (0008,0054) at study, series and image level.
This value is a list of AE titles from which the images can be retrieved. Will be NULL except for the lowest level of the query model (Image level for Patient Root or Study Root and Study level for Patient/Study Only).
- Storage-Media File-set ID (0088,0130) at level study, series and image. If Storage-Media File-set ID is not present a NULL value will be returned.
- Attributes requested by C_FIND_RQ and supported by the SCP

Note

See also → page A.2–62, *SOP Specific Conformance Statement - Find SCP*



The Find SCP returns following status codes:

C-FIND return status			
Service Status	Meaning	Protocol Codes	Related Fields
Refused	Out of Resources	A700	(0000,0902)
Failed	Identifier does not match SOP Class	A900	(0000,0901) (0000,0902)
	Unable to process	C001	(0000,0901) (0000,0902)
Cancel	Matching terminated due to Cancel request	FE00	None
Success	Matching is complete - No final Identifier is supplied	0000	None
Pending	Matches are continuing – Current Match is supplied and any Optional Keys were supported in the same manner as Required Keys	FF00	Identifier
	Matches are continuing – Warning that one or more Optional Keys were not supported for existence and/or matching for this identifier	FF01	Identifier

Associated Real-World Activity - Get SCP

Real World Activity - Get SCP

The associated Real-World activity is to respond to retrieve requests initiated from a foreign SCU. The SCP supports the query model Patient Root, Study Root and Patient/Study Only. The Storage Service Class Conformance Statement describes the C-STORE service which is generated by C-GET service. Relational retrieve operation is NOT supported.

Multiple C-GET requests over the same association are NOT supported.

Proposed Presentation Contexts - GET SCP

The Somaris/5 DICOM application will propose Presentation Contexts as shown in the following table:

Presentation Context Table

Name	Abstract Syntax		Transfer Syntax		Role	Extended Negotiation
	UID		Name List	UID List		
Patient Root Query/ Retrieve Model - GET	1.2.840.10008.5.1.4.1.2.1.3		Implicit VR Little Endian	1.2.840.10008.1.2	SCP	See Note
			Explicit VR Little Endian	1.2.840.10008.1.2.1		
			Explicit VR Big Endian	1.2.840.10008.1.2.2		
Study Root Query/ Retrieve Model - GET	1.2.840.10008.5.1.4.1.2.2.3		Implicit VR Little Endian	1.2.840.10008.1.2	SCP	See Note
			Explicit VR Little Endian	1.2.840.10008.1.2.1		
			Explicit VR Big Endian	1.2.840.10008.1.2.2		



Patient/ Study Only	1.2.840.10008.5.1.4.1.2.3.3	Implicit VR Little Endian	1.2.840.10008.1.2	SCP	See Note
Query/ Retrieve		Explicit VR Little Endian	1.2.840.10008.1.2.1		
Model - GET		Explicit VR Big Endian	1.2.840.10008.1.2.2		

Note

C-GET Extended Negotiation will be NOT supported by the SCP.

SOP Specific Conformance Statement - Get SCP

The order of preference in accepting a Transfer syntax is:

1. Explicit VR Little Endian
2. Explicit VR Big Endian
3. Implicit VR Little Endian

At association establishment time the C-GET presentation context must be negotiated along with the C-STORE sub-operations which must be accomplished on the same association as the C-GET operation. Relational retrieve operation is NOT supported.

All unique keys have to be supplied according to the selected Query/Retrieve Level. The related tables in the C-FIND SCP section will give information about "U" marked key attributes.

Note

In DICOM wildcard queries the symbol '?' is treated as '*' by Find SCP.
So a wildcard query with "?abc*" is actually treated as "*abc*"

The Get SCP returns following status codes:

C-MOVE return status			
Service Status	Meaning	Protocol Codes	Related Fields
Refused	Out of Resources - Unable to calculate number of matches	A701	(0000,0902)
	Out of Resources - Unable to perform suboperations	A702	(0000,1020) (0000,1021) (0000,1022) (0000,1023)
Failed	Identifier does not match SOP Class	A900	(0000,0901) (0000,0902)
	Unable to process	C001	(0000,0901) (0000,0902)
Cancel	Sub-operations terminated due to Cancel Indication	FE00	(0000,1020) (0000,1021) (0000,1022) (0000,1023)
Warning	Sub-operations Complete - One or more Failures of Warnings	B000	(0000,1020) (0000,1021) (0000,1022) (0000,1023)
Pending	Sub-operations are continuing	FF00	(0000,1020) (0000,1021) (0000,1022) (0000,1023)
Success	Sub-operations Complete - No Failures or Warning	0000	(0000,1020) (0000,1021) (0000,1022) (0000,1023)

Associated Real-World Activity - Move SCP

Real-World Activity - Move SCP

The associated Real-World activity is to respond to retrieve requests to an SCU. The SCP supports the query model Patient Root, Study Root and Patient/Study Only. The Storage Service Class Conformance Statement describes the C-STORE service which is generated by the C-MOVE service. Relational retrieve operation is NOT supported.

Multiple C-MOVE requests over the same association are NOT supported.

Accepted Presentation Contexts - Move SCP

The Somaris/5 DICOM application will propose Presentation Contexts as shown in the following table:

Presentation Context Table

Abstract Syntax		Transfer Syntax		Role	Extended Negotiation
Name	UID	Name List	UID List		
Patient Root Query/Retrieve Model - MOVE	1.2.840.10008.5.1.4.1.2.1.2	Implicit VR Little Endian	1.2.840.10008.1.2	SCP	See Note
		Explicit VR Little Endian	1.2.840.10008.1.2.1		
		Explicit VR Big Endian	1.2.840.10008.1.2.2		
Study Root Query/Retrieve Model - MOVE	1.2.840.10008.5.1.4.1.2.2.2	Implicit VR Little Endian	1.2.840.10008.1.2	SCP	See Note
		Explicit VR Little Endian	1.2.840.10008.1.2.1		
		Explicit VR Big Endian	1.2.840.10008.1.2.2		
Patient/Study Only Query/Retrieve Model - MOVE	1.2.840.10008.5.1.4.1.2.3.2	Implicit VR Little Endian	1.2.840.10008.1.2	SCP	See Note
		Explicit VR Little Endian	1.2.840.10008.1.2.1		
		Explicit VR Big Endian	1.2.840.10008.1.2.2		

Note

C-MOVE Extended Negotiation will be NOT supported by the SCP.

SOP Specific Conformance Statement - Move SCP

The order of preference in accepting a Transfer syntax is:

1. Explicit VR Little Endian
2. Explicit VR Big Endian
3. Implicit VR Little Endian

At association establishment time the C-MOVE presentation context shall be negotiated. The C-STORE sub-operations is done on a different association, specified in the C-MOVE request, to transfer images to another SCP of the Storage Service Class. Relational retrieve operation is NOT supported.

All unique keys have to be supplied according to the selected Query/Retrieve Level. The related tables in the C-FIND SCP section will give information about "U" marked key attributes.

Note

In DICOM wildcard queries the symbol '?' is treated as '*' by Find SCP.
So a wildcard query with "?abc*" is actually treated as "*abc*"

The Move SCP returns following status codes:

C-MOVE return status			
Service Status	Meaning	Protocol Codes	Related Fields
Refused	Out of Resources - Unable to calculate number of matches	A701	(0000,0902)
	Out of Resources - Unable to perform suboperations	A702	(0000,1020) (0000,1021) (0000,1022) (0000,1023)
	Identifier does not match SOP Class	A900	(0000,0901) (0000,0902)
Failed	Unable to process	C001	(0000,0901) (0000,0902)
Cancel	Sub-operations terminated due to Cancel Indication	FE00	(0000,1020) (0000,1021) (0000,1022) (0000,1023)
Warning	Sub-operations Complete - One or more Failures of Warnings	B000	(0000,1020) (0000,1021) (0000,1022) (0000,1023)
Pending	Sub-operations are continuing	FF00	(0000,1020) (0000,1021) (0000,1022) (0000,1023)
Success	Sub-operations Complete - No Failures or Warning	0000	(0000,1020) (0000,1021) (0000,1022) (0000,1023)

Print AE Specification

The print management SCU (HCS) invokes print management DIMSE services to transfer images from the local AE to the remote SCP AE to print the images with the defined film format and size on a selected network DICOM hardcopy printer. See DICOM part 4 annex H. This is done in a "full-page" print mode.

Somaris/5 DICOM implementation provides Standard Conformance to the following DICOM V3.0 Basic Grayscale Print Management Meta SOP Classes as an SCU:

Basic Gray Scale Print Management Meta SOP-Classes	
SOP Class Name	SOP Class UID
Basic Grayscale Print Management Meta SOP Class	1.2.840.10008.5.1.1.9
– Basic Film Session SOP Class	1.2.840.10008.5.1.1.1
– Basic Film Box SOP Class	1.2.840.10008.5.1.1.2
– Basic Grayscale Image Box SOP Class	1.2.840.10008.5.1.1.4
– Printer SOP Class	1.2.840.10008.5.1.1.16
– Print Job SOP Class	1.2.840.10008.5.1.1.14
– Presentation LUT SOP Class	1.2.840.10008.5.1.1.23

Basic Color Print Management Meta SOP-Classes	
SOP Class Name	SOP Class UID
Basic Color Print Management Meta SOP Class	1.2.840.10008.5.1.1.18
– Basic Film Session SOP Class	1.2.840.10008.5.1.1.1
– Basic Film Box SOP Class	1.2.840.10008.5.1.1.2
– Basic Color Image Box SOP Class	1.2.840.10008.5.1.1.4.1
– Printer SOP Class	1.2.840.10008.5.1.1.16
– Print Job SOP Class	1.2.840.10008.5.1.1.14

Association Establishment Policies

General

Whenever a film is completely set up and printed by command or automatism, the job is prepared for processing. As soon as the queue is ready to process the job is activated and carried out according to the processing data. The related Print application will initiate an association to the print destination and process the printing of the related information.

The default PDU size will be 28 KB.

Number of Associations

The Somaris/5 DICOM Print application initiates one association at a time for print device configured.

Asynchronous Nature

The Somaris/5 DICOM implementation does not support asynchronous communication (multiple outstanding transactions over a single association).

Implementation Identifying Information

The Somaris/5 DICOM implementation provides the Implementation Class UID of

❑ "1.3.12.2.1107.5.1.4"

and an Implementation Version Name of

❑ "SIEMENS_S5VB41A".

Association Initiation Policy

Triggered by the Print job queue the Print Management SCU establishes an association by using the DICOM association services. With the help of the N-GET request for the printer SOP Class the Status is determined before printing.

In case no problem is encountered with the N-CREATE/N-SET Services for the related Basic Print SOP Classes the film sheet is set up for printing and the image(s) is(are) transferred to the printer device.

After the last film is printed from the queue, the Print application will leave open the association for another 60 seconds. If a new film job is ready for printing within this time limit, the job will be processed immediately over the association still open. If there is no new job, the association is closed when the time out has elapsed. This is done to optimize automatic printing.

During the "idle time" (no open association to printer) the Print application will issue a cyclic camera status request (using N-GET of Printer SOP Class) every 5 minutes.

Real-World Activity

Associated Real-World Activity - Printing a Printer Job Queue Entry

Whenever a film sheet is prepared by the user, it is forwarded to the Printer Job queue. As soon as the associated Printer device is available the job is activated and an association is set up.

The film sheet is internally processed, converted to a Standard/ 1-1 page and then the page image is sent. Status is controlled by awaiting any N-EVENT message all through the transfer until the last image or film sheet is sent.

If the response from the remote application contains a status other than Success or Warning the association is aborted.

Proposed Presentation Contexts Presentation Context Table)

The Somaris/5 DICOM application will propose Presentation Contexts as shown in the following table:

Presentation context - Print SCU					
Abstract Syntax		Transfer Syntax		Role	Extended Negotiation
Name	UID	Name List	UID List		
Basic Grayscale Print Management Meta SOP class	1.2.840.10008.5.1.1.9	Implicit VR Little Endian	1.2.840.10008.1.2	SCU	None
		Explicit VR Little Endian	1.2.840.10008.1.2.1		
		Explicit VR Big Endian	1.2.840.10008.1.2.2		
Basic Color Print Management Meta SOP class	1.2.840.10008.5.1.1.18	Implicit VR Little Endian	1.2.840.10008.1.2	SCU	None
		Explicit VR Little Endian	1.2.840.10008.1.2.1		
		Explicit VR Big Endian ,	1.2.840.10008.1.2.2		
Basic film session SOP class	1.2.840.10008.5.1.1.1	Implicit VR Little Endian	1.2.840.10008.1.2	SCU	None
		Explicit VR Little Endian	1.2.840.10008.1.2.1		
		Explicit VR Big Endian	1.2.840.10008.1.2.2		
Basic film box SOP class	1.2.840.10008.5.1.1.2	Implicit VR Little Endian	1.2.840.10008.1.2	SCU	None
		Explicit VR Little Endian	1.2.840.10008.1.2.1		
		Explicit VR Big Endian	1.2.840.10008.1.2.2		
Basic grayscale image box SOP class	1.2.840.10008.5.1.1.4	Implicit VR Little Endian	1.2.840.10008.1.2	SCU	None
		Explicit VR Little Endian	1.2.840.10008.1.2.1		
		Explicit VR Big Endian	1.2.840.10008.1.2.2		
Basic color image box SOP class	1.2.840.10008.5.1.1.4.1	Implicit VR Little Endian	1.2.840.10008.1.2	SCU	None
		Explicit VR Little Endian	1.2.840.10008.1.2.1		
		Explicit VR Big Endian	1.2.840.10008.1.2.2		
Printer SOP class	1.2.840.10008.5.1.1.16	Implicit VR Little Endian	1.2.840.10008.1.2	SCU	None
		Explicit VR Little Endian	1.2.840.10008.1.2.1		
		Explicit VR Big Endian	1.2.840.10008.1.2.2		



Print Job SOP class	1.2.840.10008.5.1.1.14	Implicit VR Little Endian	1.2.840.10008.1.2	SCU	None
		Explicit VR Little Endian	1.2.840.10008.1.2.1		
		Explicit VR Big Endian	1.2.840.10008.1.2.2		
Presentation LUT SOP class	1.2.840.10008.5.1.1.23	Implicit VR Little Endian	1.2.840.10008.1.2	SCU	None
		Explicit VR Little Endian	1.2.840.10008.1.2.1		
		Explicit VR Big Endian	1.2.840.10008.1.2.2		

SOP Specific Conformance Statement - Meta SOP Classes

The Somaris/5 DICOM Print Management SCU conforms to the DICOM Basic Grayscale Print Management Meta SOP Class and Basic Color Print Management Meta SOP Class.

The application uses a setting platform to define the properties of the connected DICOM SCP, e.g.:

- maximum number of print jobs in the queue
- maximum number of print copies
- supported film sizes of the connected DICOM SCP
- supported film formats of the DICOM SCP
- lookup table definition

The printing is only suspended in the case of a failure return status of the SCP.

Basic Film Session SOP Class

The Basic Film Session information object definition describes all the user defined parameter which are common for all the films of a film session. The Basic Film Session refers to one or more Basic Film Boxes and that are printed on one hardcopy printer.

The Somaris/5 DICOM Print application supports the following DIMSE Service Elements for the Basic Film Session SOP class as SCU:

- N-CREATE
- N-DELETE

The Basic Film Session SOP class N-CREATE-RQ (SCU) uses following attributes:

Attribute name	Tag	Usage SCU	Supported Values
Number of Copies	(2000,0010)	U	1
Medium Type	(2000,0030)	U	BLUE FILM CLEAR FILM PAPER
Film Destination	(2000,0040)	U	MAGAZINE PROCESSOR

The number of copies sent to the DICOM printer is always 1, the job is sent n times for n copies.

The Affected SOP Instance UID received with N-CREATE-RSP message from SCP will be kept internally and used for later requests (e.g. N-DELETE-RQ) on the Basic Film Session SOP Class - see table below:

Attribute name	Tag	Source of information
Requested SOP Instance UID	(0000,1000) -> (0000,1001)	Affected SOP Instance UID of N-CREATE-RSP on Basic Film Session

The N-DELETE-RQ on the Basic Film Session SOP Class is used to delete the complete Basic Film Session SOP Instance hierarchy.

The Basic Film Session SOP class interprets the following status codes (from N-CREATE-RSP, N-DELETE-RSP messages):

Service Status	Meaning	Protocol Codes
Failure	Film session SOP instances hierarchy does not contain film box SOP instances	C600
	Unable to create print job, print queue is full	C601
	Image size is larger than images box size	C603
Warning	Memory allocation not supported	B600
	Film session printing is not supported	B601
	Film box does not contain image box (empty page)	B602
Success	Film belonging to the film session are accepted for printing	0000

Basic Film Box SOP Class

The Basic Film Box information object definition describes all the user defined parameter of one film of the film session. The Basic Film Box information description defines the presentation parameters which are common for all images on a given sheet of film.

The Basic Film Box refers to one or more Image Boxes.

Supported as SCU are:

- N-CREATE
- N-ACTION
- N-DELETE

The Basic Film Box SOP class N-CREATE-RQ message uses following attributes (the used values for each attribute depend on the DICOM Printer configuration within the Somaris/5 DICOM print management SCU):

Attribute name	Tag	Usage SCU	Supported Values
Image Display Format	(2010,0010)	M	STANDARDIC-R
Referenced Film Session Sequence	(2010,0500)	M	
> Referenced SOP Class UID	(0008,1150)	M	1.2.840.10008.5.1.1.1
> Referenced SOP Instance UID	(0008,1155)	M	
Film Orientation	(2010,0040)	M	PORTRAIT LANDSCAPE
Film Size ID	(2010,0050)	M	8INX10IN 10INX12IN 10INX14IN 11INX14IN 14INX14IN 14INX17IN 24CMX24CM 24CMX30CM

Attribute name	Tag	Usage SCU	Supported Values
Magnification Type	(2010,0060)	M	BILINEAR CUBIC NONE REPLICATE
Border Density	(2010,0100)	U	BLACK WHITE
Max Density	(2010,0130)	U	0 < Value
Min Density	(2010,0120)	U	0 < Value < 50
Illumination	(2010,015E)	U	0 < Value Required if Presentation LUT is present
Reflective Ambient Light	(2010,0160)	U	0 < Value Required if Presentation LUT is present
Referenced Presentation LUT Sequence	(2050,0500)	U	

For Page Mode printing the Image Display format used is Standard\1,1. For Image Mode Printing the Image Display format used is Standard\C,R where C is the number of Columns and R is the number of Rows as specified in the Hardcopy Layout.

The N-CREATE-RSP message from the Print SCP includes the Referenced Image Box Sequence with its SOP Class / Instance UID pairs which will be kept internally to be further used for the subsequent Basic Image Box SOP Class N-SET-RQ messages.

When all Image Boxes (including parameters) for the film sheet have been set, the Somaris/5 DICOM print manager will issue a N-ACTION-RQ message with the SOP Instance UID of the Basic Film Box (returned in N-CREATE-RSP of Basic Film Box SOP class) and the Action Type ID of 1.

The affected SOP Instance UID received with N-CREATE-RSP message will be kept internally and used for later requests (e.g. N-DELETE-RQ) on the Basic Film Box SOP Class - see table below:

Attribute name	Tag	Source of information
Requested SOP Instance UID	(0000,1000) -> (0000,1001)	Affected SOP Instance UID of N-CREATE-RSP on Basic Film Box

The Basic Film Box SOP class interprets the following status codes:

Service Status	Meaning	Protocol Codes
Failure	Unable to create print job; print queue is full	C602
Warning	Image size is larger than image box size	C603
	Film box does not contain image box (empty page)	B603
Success	Requested MinDensity or MaxDensity outside of printer's operating range	B605
	Film accepted for printing	0000

Basic Grayscale Image Box SOP Class

The Basic Grayscale Image Box information object definition is the presentation of an image and image related data in the image area of a film. The Basic Image Box information describes the presentation parameters and image pixel data which apply to a single image of a sheet of film.

The Grayscale Image Box SOP class uses only the N-SET-RQ with the following attributes:

Attribute name	Tag	Usage SCU	Supported Values
Image Position	(2020,0010)	M	1
Basic Grayscale Image Sequence	(2020,0110)	M	
> Samples Per Pixel	(0028,0002)	M	1
> Photometric Interpretation	(0028,0004)	M	MONOCH-ROME2
> Rows	(0028,0010)	M	
> Columns	(0028,0011)	M	
> Pixel Aspect Ratio	(0028,0034)	M	
> Bits Allocated	(0028,0100)	M	8,16
> Bits Stored	(0028,0101)	M	8,12
> High Bit	(0028,0102)	M	7,11
> Pixel Representation	(0028,0103)	M	0
> Pixel Data	(7FE0,0010)	M	

The Grayscale Image Box SOP class interprets following status codes:

Service Status	Meaning	Protocol Codes
Failure	Image contains more pixel than printer can print in Image box	C603
	Insufficient memory in printer to store the image	C605
Warning	Requested MinDensity or MaxDensity outside of printer's operating range	B605
Success		0000

Basic Color Image Box SOP Class

The Basic Color Image Box information object definition is the presentation of an image and image related data in the image area of a film. The Basic Image Box information describes the presentation parameters and image pixel data which apply to a single image of a sheet of film.

The Color Image Box SOP class uses only the N-SET-RQ with the following attributes:

Attribute name	Tag	Usage SCU	Supported Values
Image Position	(2020,0010)	M	1
Basic Color Image Sequence	(2020,0111)	M	
> Samples Per Pixel	(0028,0002)	M	3
> Photometric Interpretation	(0028,0004)	M	RGB
> Planar Configuration	(0028,0006)	M	0
> Rows	(0028,0010)	M	
> Columns	(0028,0011)	M	
> Pixel Aspect Ratio	(0028,0034)	M	
> Bits Allocated	(0028,0100)	M	8
> Bits Stored	(0028,0101)	M	8
> High Bit	(0028,0102)	M	7
> Pixel Representation	(0028,0103)	M	0
> Pixel Data	(7FE0,0010)	M	

The Color Image Box SOP class interprets following status codes:

Service Status	Meaning	Protocol Codes
Warning	Image size larger than image box size.	B604
Failure	Image contains more pixel than printer can print in Image box	C603
	Insufficient memory in printer to store the image	C605
Success		0000

Presentation LUT SOP Class

The objective of the Presentation LUT is to realize image hardcopy printing tailored for specific modalities, applications, and user preferences.

The output of the Presentation LUT is Presentation Values (P-Values). P-Values are approximately related to human perceptual response. They are intended to facilitate common input for hardcopy. P-Values are intended to be independent of the specific class or characteristics of the hardcopy device.

Attributes of the N_CREATE_RQ on the Presentation LUT SOP Class

Attribute name	Tag	Usage SCU	Supported Values
Presentation LUT Shape	(2050,0020)	U	IDENTITY

The affected SOP Instance UID received with N-CREATE-RSP message will be kept internally and is used for later requests on the Basic Film Box (N-CREATE-RQ) and on the Presentation LUT (N-DELETE-RQ) - see below.

Attribute name	Tag	Source of information
Requested SOP Instance UID	(0000,1000) -> (0000,1001)	Affected SOP Instance UID of N-CREATE-RSP on Presentation LUT

The Presentation LUT SOP class interprets the following status codes:

Service Status	Meaning	Protocol Codes
Warning	Requested Min Density or Max Density outside the HCD´s operating range. HCD will use its respective minimum or maximum density value instead.	B605
Success	Presentation LUT successfully created	0000

Printer SOP Class

The Printer SOP Class is the possibility to monitor the status of the hardcopy printer in a synchronous and an asynchronous way.

The SCU uses the mandatory N-EVENT Report DIMSE service to monitor the changes of the printer status in an asynchronous way.

It can directly ask the Printer (SCP) for its status or can receive Events from the Print SCP asynchronously:

- N_GET as SCU
- N_EVENT_REPORT as SCU

In both cases the following information is supported:

Event type name	Event	Attributes	Tag	Usage SCU
Normal	1			
Warning	2	Printer Status Info	(2110,0020)	U
Failure	3	Printer Status Info	(2110,0020)	U

Attribute name	Tag	Usage SCP	supported values
Printer Status	(2110,0010)	M	NORMAL FAILURE WARNING
Printer Status Info	(2110,0020)	M	see → page A.2–108.

For a detailed description of how Somaris/5 reacts to the various messages please refer to → page A.2–108, *DICOM Print SCU - detailed status displays*.

Print Job SOP Class

The Print Job SOP Class is the possibility to monitor the execution of the print process.

The Somaris/5 DICOM Print application supports the optional N-EVENT-REPORT DIMSE service to receive the changes of the print job status in an asynchronous way.

It can receive events from the Print SCP asynchronously:

- N-EVENT-REPORT

Note

Somaris/5 does not support receiving N-EVENT from the camera during print sessions, normally this is configurable in the camera.

The following information is supported:

Event type name	Event	Attributes	Tag	Usage SCU
Pending	1	Execution Status Info	(2100,0030)	U
		Print Job ID	(2100,0010)	- (Print Queue Management SOP Class not supported)
		Film Session Label	(2000,0050)	U
		Printer Name	(2110,0030)	U
Printing	2	Execution Status Info	(2100,0030)	U
		Print Job ID	(2100,0010)	- (Print Queue Management SOP Class not supported)
		Film Session Label	(2000,0050)	U
		Printer Name	(2110,0030)	U
Done	3	Execution Status Info	(2100,0030)	U
		Print Job ID	(2100,0010)	- (Print Queue Management SOP Class not supported)
		Film Session Label	(2000,0050)	U
		Printer Name	(2110,0030)	U

Event type name	Event	Attributes	Tag	Usage SCU
Failure	4	Execution Status Info	(2100,0030)	U
		Print Job ID	(2100,0010)	- (Print Queue Management SOP Class not supported)
		Film Session Label	(2000,0050)	U
		Printer Name	(2110,0030)	U

For a detailed description of how Somaris/5 reacts to the various messages please refer to → page A.2–108, *DICOM Print SCU - detailed status displays*.

DICOM Print SCU - detailed status displays

The following tables document the behavior of the Somaris/5 system in response to messages received for the printer SOP class and the print job SOP class.

Definitions of camera symbols:

- Idle: Camera is installed and ready; idle icon is displayed.
- Interact: The user has to react in near future, but not immediately.
- Example: A camera was low in 8x10 clear sheets: LOW 8x10 CLR was sent by N-EVENT-REPORT.
- Queue Stopped: The user has to react immediately. Either the camera needs immediate interaction or a job has been aborted.
Example: A camera is out of 8x10 clear sheets, or camera is down, or a film job is aborted.

Note

Different camera symbols are displayed according to the Printer Status Info.

The Printer Status (Success, Warning, Failure) is not evaluated, since the Printer Status Info is much more detailed and allows a more appropriate reaction of the system.



Printer Status Infos within Printer SOP Class/Execution Status Infos within Print Job SOP Class

Printer Status info/Execution Status info	Description	Message string visible in the Status Bar	Other action for UI/camera symbol
NORMAL	Camera is ready.	Camera is ready.	<None>/idle
BAD RECEIVE MGZ	There is a problem with the film receive magazine. Films from the printer cannot be transported into the magazine.	Problem with receive magazine.	<None>/interact
BAD SUPPLY MGZ	There is a problem with a film supply magazine. Films from this magazine cannot be transported into the printer.	Problem with supply magazine.	<None>/interact
CALIBRATING	Printer is performing self calibration, it is expected to be available for normal operation shortly.	Self calibration. Please wait.	<None>/idle
CALIBRATION ERR	An error in the printer calibration has been detected, quality of processed films may not be optimal.	Problem in calibration. Film quality may not be optimal.	<None>/interact
CHECK CHEMISTRY	A problem with the processor chemicals has been detected, quality of processed films may not be optimal.	Problem with chemistry. Film quality may not be optimal.	<None>/interact
CHECK SORTER	There is an error in the film sorter.	Error in film sorter.	<None>/interact



Printer Status Infos within Printer SOP Class/Execution Status Infos within Print Job SOP Class			
Printer Status info/Execution Status info	Description	Message string visible in the Status Bar	Other action for UI/camera symbol
CHEMICALS EMPTY	There are no processing chemicals in the processor, films will not be printed and processed until the processor is back to normal.	Camera chemistry empty. Please check.	<None>/interact
CHEMICALS LOW	The chemical level in the processor is low, if not corrected, it will probably shut down soon.	Camera chemistry low. Please check.	<None>/interact
COVER OPEN	One or more printer or processor covers, drawers, doors are open.	Camera cover, drawer or door open.	<None>/interact
ELEC CONFIG ERR	Printer configured improperly for this job.	Camera configured improperly for this job. Queue stopped.	Queue for this camera will be STOPPED/Queue stopped
ELEC DOWN	Printer is not operating due to some unspecified electrical hardware problem.	Camera electrical hardware problem.	<None>/interact
ELEC SW ERROR	Printer not operating for some unspecified software error.	Camera software problem. Queue stopped.	Queue for this camera will be STOPPED/queue stopped
EMPTY 8x10	The 8x10 inch film supply magazine is empty.	8x10 film supply empty.	<None>/interact



Printer Status Infos within Printer SOP Class/Execution Status Infos within Print Job SOP Class

Printer Status info/Execution Status info	Description	Message string visible in the Status Bar	Other action for UI/camera symbol
EMPTY 8x10 BLUE	The 8x10 inch blue film supply magazine is empty.	8x10 blue film supply empty.	<None>/interact
EMPTY 8x10 CLR	The 8x10 inch clear film supply magazine is empty.	8x10 clear film supply empty.	<None>/interact
EMPTY 8x10 PAPR	The 8x10 inch paper supply magazine is empty.	8x10 paper supply empty.	<None>/interact
EMPTY 10x12	The 10x12 inch film supply magazine is empty.	10x12 film supply empty.	<None>/interact
EMPTY 10x12 BLUE	The 10x12 inch blue film supply magazine is empty.	10x12 blue film supply empty.	<None>/interact
EMPTY 10x12 CLR	The 10x12 inch clear film supply magazine is empty.	10x12 clear film supply empty.	<None>/interact
EMPTY 10x12 PAPR	The 10x12 inch paper supply magazine is empty.	10x12 paper supply empty.	<None>/interact
EMPTY 10x14	The 10x14 inch film supply magazine is empty.	10x14 film supply empty.	<None>/interact
EMPTY 10x14 BLUE	The 10x14 inch blue film supply magazine is empty.	10x14 blue film supply empty.	<None>/interact
EMPTY 10x14 CLR	The 10x14 inch clear film supply magazine is empty.	10x14 clear film supply empty.	<None>/interact
EMPTY 10x14 PAPR	The 10x14 inch paper supply magazine is empty.	10x14 paper supply empty.	<None>/interact
EMPTY 11x14	The 11x14 inch film supply magazine is empty.	11x14 film supply empty.	<None>/interact



Printer Status Infos within Printer SOP Class/Execution Status Infos within Print Job SOP Class

Printer Status info/Execution Status info	Description	Message string visible in the Status Bar	Other action for UI/camera symbol
EMPTY 11x14 BLUE	The 11x14 inch blue film supply magazine is empty.	11x14 blue film supply empty.	<None>/interact
EMPTY 11x14 CLR	The 11x14 inch clear film supply magazine is empty.	11x14 clear film supply empty.	<None>/interact
EMPTY 11x14 PAPR	The 11x14 inch paper supply magazine is empty.	11x14 paper supply empty.	<None>/interact
EMPTY 14x14	The 14x14 inch film supply magazine is empty.	14x14 film supply empty.	<None>/interact
EMPTY 14x14 BLUE	The 14x14 inch blue film supply magazine is empty.	14x14 blue film supply empty.	<None>/interact
EMPTY 14x14 CLR	The 14x14 inch clear film supply magazine is empty.	14x14 clear film supply empty.	<None>/interact
EMPTY 14x14 PAPR	The 14x14 inch paper supply magazine is empty.	14x14 paper supply empty.	<None>/interact
EMPTY 14x17	The 14x17 inch film supply magazine is empty.	14x17 film supply empty.	<None>/interact
EMPTY 14x17 BLUE	The 14x17 inch blue film supply magazine is empty.	14x17 blue film supply empty.	<None>/interact
EMPTY 14x17 CLR	The 14x17 inch clear film supply magazine is empty.	14x17 clear film supply empty.	<None>/interact
EMPTY 14x17 PAPR	The 14x17 inch paper supply magazine is empty.	14x17 paper supply empty.	<None>/interact
EMPTY 24x24	The 24x24 inch film supply magazine is empty.	24x24 film supply empty.	<None>/interact



Printer Status Infos within Printer SOP Class/Execution Status Infos within Print Job SOP Class

Printer Status info/Execution Status info	Description	Message string visible in the Status Bar	Other action for UI/camera symbol
EMPTY 24x24 BLUE	The 24x24 inch blue film supply magazine is empty.	24x24 blue film supply empty.	<None>/interact
EMPTY 24x24 CLR	The 24x24 inch clear film supply magazine is empty.	24x24 clear film supply empty.	<None>/interact
EMPTY 24x24 PAPER	The 24x24 inch paper supply magazine is empty.	24x24 paper supply empty.	<None>/interact
EMPTY 24x30	The 24x30 inch film supply magazine is empty.	24x30 film supply empty.	<None>/interact
EMPTY 24x30 BLUE	The 24x30 inch blue film supply magazine is empty.	24x30 blue film supply empty.	<None>/interact
EMPTY 24x30 CLR	The 24x30 inch clear film supply magazine is empty.	24x30 clear film supply empty.	<None>/interact
EMPTY 24x30 PAPER	The 24x30 inch paper supply magazine is empty.	24x30 paper supply empty.	<None>/interact
EMPTY A4 PAPER	The A4 paper supply magazine is empty.	A4 paper supply empty.	<None>/interact
EMPTY A4 TRANS	The A4 transparency supply magazine is empty.	A4 transparency supply empty.	<None>/interact
EXPOSURE FAILURE	The exposure device has failed due to some unspecified reason.	Exposure device has failed.	<None>/interact
FILM JAM	A film transport error has occurred and a film is jammed in the printer or processor.	Film jam.	<None>/interact



Printer Status Infos within Printer SOP Class/Execution Status Infos within Print Job SOP Class			
Printer Status info/Execution Status info	Description	Message string visible in the Status Bar	Other action for UI/camera symbol
FILM TRANSP ERR	There is a malfunction with the film transport, there may or may not be a film jam.	Film transport problem.	<None>/interact
FINISHER EMPTY	The finisher is empty.	Finisher is empty.	<None>/interact
FINISHER ERROR	The finisher is not operating due to some unspecified reason.	Finisher problem.	<None>/interact
FINISHER LOW	The finisher is low on supplies.	Finisher low.	<None>/interact
LOW 8x10	The 8x10 inch film supply magazine is low.	8x10 film supply low.	<None>/interact
LOW 8x10 BLUE	The 8x10 inch blue film supply magazine is low.	8x10 blue film supply low.	<None>/interact
LOW 8x10 CLR	The 8x10 inch clear film supply magazine is low.	8x10 clear film supply low.	<None>/interact
LOW 8x10 PAPER	The 8x10 inch paper supply magazine is low.	8x10 paper supply low.	<None>/interact
LOW 10x12	The 10x12 inch film supply magazine is low.	10x12 film supply low.	<None>/interact
LOW 10x12 BLUE	The 10x12 inch blue film supply magazine is low.	10x12 blue film supply low.	<None>/interact
LOW 10x12 CLR	The 10x12 inch clear film supply magazine is low.	10x12 clear film supply low.	<None>/interact



Printer Status Infos within Printer SOP Class/Execution Status Infos within Print Job SOP Class

Printer Status info/Execution Status info	Description	Message string visible in the Status Bar	Other action for UI/camera symbol
LOW 10x12 PAPR	The 10x12 inch paper supply magazine is low.	10x12 paper supply low.	<None>/interact
LOW 10x14	The 10x14 inch film supply magazine is low.	10x14 film supply low.	<None>/interact
LOW 10x14 BLUE	The 10x14 inch blue film supply magazine is low.	10x14 blue film supply low.	<None>/interact
LOW 10x14 CLR	The 10x14 inch clear film supply magazine is low.	10x14 clear film supply low.	<None>/interact
LOW 10x14 PAPR	The 10x14 inch paper supply magazine is low.	10x14 paper supply low.	<None>/interact
LOW 11x14	The 11x14 inch film supply magazine is low.	11x14 film supply low.	<None>/interact
LOW 11x14 BLUE	The 11x14 inch blue film supply magazine is low.	11x14 blue film supply low.	<None>/interact
LOW 11x14 CLR	The 11x14 inch clear film supply magazine is low.	11x14 clear film supply low.	<None>/interact
LOW 11x14 PAPR	The 11x14 inch paper supply magazine is low.	11x14 paper supply low.	<None>/interact
LOW 14x14	The 14x14 inch film supply magazine is low.	14x14 film supply low.	<None>/interact
LOW 14x14 BLUE	The 14x14 inch blue film supply magazine is low.	14x14 blue film supply low.	<None>/interact
LOW 14x14 CLR	The 14x14 inch clear film supply magazine is low.	14x14 clear film supply low.	<None>/interact

Printer Status Infos within Printer SOP Class/Execution Status Infos within Print Job SOP Class			
Printer Status info/Execution Status info	Description	Message string visible in the Status Bar	Other action for UI/camera symbol
LOW 14x14 PAPER	The 14x14 inch paper supply magazine is low.	14x14 paper supply low.	<None>/interact
LOW 14x17	The 14x17 inch film supply magazine is low.	14x17 film supply low.	<None>/interact
LOW 14x17 BLUE	The 14x17 inch blue film supply magazine is low.	14x17 blue film supply low.	<None>/interact
LOW 14x17 CLR	The 14x17 inch clear film supply magazine is low.	14x17 clear film supply low.	<None>/interact
LOW 14x17 PAPER	The 14x17 inch paper supply magazine is low.	14x17 paper supply low.	<None>/interact
LOW 24x24	The 24x24 inch film supply magazine is low.	24x24 film supply low.	<None>/interact
LOW 24x24 BLUE	The 24x24 inch blue film supply magazine is low.	24x24 blue film supply low.	<None>/interact
LOW 24x24 CLR	The 24x24 inch clear film supply magazine is low.	24x24 clear film supply low.	<None>/interact
LOW 24x24 PAPER	The 24x24 inch paper supply magazine is low.	24x24 paper supply low.	<None>/interact
LOW 24x30	The 24x30 inch film supply magazine is low.	24x30 film supply low.	<None>/interact
LOW 24x30 BLUE	The 24x30 inch blue film supply magazine is low.	24x30 blue film supply low.	<None>/interact
LOW 24x30 CLR	The 24x30 inch clear film supply magazine is low.	24x30 clear film supply low.	<None>/interact



Printer Status Infos within Printer SOP Class/Execution Status Infos within Print Job SOP Class

Printer Status info/Execution Status info	Description	Message string visible in the Status Bar	Other action for UI/camera symbol
LOW 24x30 PAPER	The 24x30 inch paper supply magazine is low.	24x30 paper supply low.	<None>/interact
LOW A4 PAPER	The A4 paper supply magazine is low.	A4 paper supply low.	<None>/interact
LOW A4 TRANS	The A4 transparency supply magazine is low.	A4 transparency supply low.	<None>/interact
NO RECEIVE MGZ	The film receive magazine no available.	Film receiver not available.	<None>/interact
NO RIBBON	The ribbon cartridge needs to be replaced.	Replace ribbon cartridge.	<None>/interact
NO SUPPLY MGZ	The film supply magazine specified for this job is not available.	Film supply not available.	<None>/interact
CHECK PRINTER	The printer is not ready at this time, operator intervention is required to make the printer available.	Check camera.	<None>/interact
CHECK PROC	The processor is not ready at this time, operator intervention is required to make the printer available.	Check processor.	<None>/interact
PRINTER DOWN	The printer is not operating due to some unspecified reason.	Camera down.	<None>/interact



Printer Status Infos within Printer SOP Class/Execution Status Infos within Print Job SOP Class			
Printer Status info/Execution Status info	Description	Message string visible in the Status Bar	Other action for UI/camera symbol
PRINTER INIT	The printer is not ready at this time, it is expected to become available without intervention, For example, it may be in a normal warm-up state.	Camera initializing.	<None>/idle
PRINTER OFFLINE	The printer has been disabled by an operator or service person.	Camera off-line.	<None>/interact
PROC DOWN	The processor is not operating due to some unspecified reason.	Processor down.	<None>/interact
PROC INIT	The processor is not ready at this time, it is expected to become available without intervention. For example, it may be in a normal warm-up state.	Processor initializing.	<None>/idle
PROC OVERFLOW FL	Processor chemicals are approaching the overflow full mark.	Processor chemicals overflow.	<None>/interact
PROC OVERFLOW HI	Processor chemicals have reached the overflow full mark.	Processor chemicals near overflow.	<None>/interact
QUEUED	Print job in Queue	-	<None>/idle
RECEIVER FULL	The Film receive magazine is full.	Receiver full.	<None>/interact



Printer Status Infos within Printer SOP Class/Execution Status Infos within Print Job SOP Class

Printer Status info/Execution Status info	Description	Message string visible in the Status Bar	Other action for UI/camera symbol
REQ MED NOT INST	The requested film, paper, or other media supply magazine is installed in the printer, but may be available with operator intervention.	Install media supply.	<None>/interact
REQ MED NOT AVAI	The requested film, paper, or other media requested is not available on this printer.	Media supply not available on this camera. Queue stopped. Change camera.	Queue for this camera will be STOPPED/queue stopped
RIBBON ERROR	There is an unspecified problem with the print ribbon.	Error with print ribbon.	<None>/interact
SUPPLY EMPTY	The printer is out of film.	Camera out of film.	<None>/interact
SUPPLY LOW	The film supply is low.	Film supply low.	<None>/interact
UNKNOWN	There is an unspecified problem.	Unspecified problem with camera.	<None>/interact



Printer Status Infos: Additional Agfa printer status infos			
Printer Status info	Description	Message string visible in the Status Bar	Other action for syngo/camera symbol
WARMING UP	Printer is in the warm-up stage. Spooling of print jobs to disk is still possible.	Camera is warming up.	<None>idle
OFFLINE	Printer is switched off-line. Spooling of print jobs to disk is still possible.	Camera is switched off-line.	<None>/interact
NONE	General printer warning, no specific information is available. Spooling of print jobs to disk is still possible.	-	<None>/idle

Printer Status Infos: Additional Kodak infos for Pacs Link (formerly Imation cameras)			
Printer Status info	Description	Message string visible in the Status Bar	Other action for syngo/camera symbol
SUPPLY MGZ ERR	The supply magazine has an error.	Film supply has an error.	<None>/interact



Printer Status Infos: Additional Kodak infos for Kodak 190

Printer Status info	Description	Message string visible in the Status Bar	Other action for <i>syngo</i>/camera symbol
PRINTER STOPPED	The printer has stopped	Camera has stopped.	<None>/interact
FATAL ERROR	Fatal error.	Fatal error. Queue stopped.	Queue for this camera will be STOPPED/queue stopped

Printer Status Infos: Additional Kodak infos for 2180/1120

Printer Status info	Description	Message string visible in the Status Bar	Other action for <i>syngo</i>/camera symbol
PRINTER NOT RDY	Printer not ready.	Camera not ready.	<None>/interact
CHECK PROCESSOR	Check processor.	Check processor.	<None>/interact
NO TONER	No toner.	No toner.	<None>/interact
FATAL	Fatal error.	Fatal error. Queue stopped.	Queue for this camera will be STOPPED/queue stopped

Printer Status Infos: Additional Codonics infos

Printer Status info	Description	Message string visible in the Status Bar	Other action for <i>syngo</i>/camera symbol
STANDARD	Printer is ready.	Camera is ready.	<None>/Normal
LOAD A-SIZE	Load A-size media.	Load A-size media.	<None>/interact
LOAD A-DVPAPER	Load A-size black and white paper.	Load A-size black and white paper.	<None>/interact
LOAD A-CVPAPER	Load A-size color paper.	Load A-size color paper.	<None>/interact
LOAD A-CVTRANS	Load A-size transparencies.	Load A-size transparencies.	<None>/interact
LOAD A4-SIZE	Load A4-size media.	Load A4-size media.	<None>/interact
LOAD A4-DVPAPER	Load A4-size black and white paper.	Load A4-size black and white paper.	<None>/interact



Printer Status Infos: Additional Codonics infos			
Printer Status info	Description	Message string visible in the Status Bar	Other action for <i>syngo</i> /camera symbol
LOAD A4-CVPAPER	Load A4-size color paper.	Load A4-size color paper.	<None>/interact
LOAD A4-CVTRANS	Load A4-size transparencies.	Load A4-size transparencies.	<None>/interact
LOAD LA-SIZE	Load LA-size media.	Load LA-size media.	<None>/interact
LOAD LA-DVPAPER	Load LA-size black and white paper.	Load LA-size black and white paper.	<None>/interact
LOAD LA-CVPAPER	Load LA-size color paper.	Load LA-size color paper.	<None>/interact
LOAD LA-CVTRANS	Load LA-size transparencies.	Load LA-size transparencies.	<None>/interact
LOAD LA4-SIZE	Load LA4-size media.	Load LA4-size media.	<None>/interact
LOAD LA4-DVPAPER	Load LA4-size black and white paper.	Load LA4-size black and white paper.	<None>/interact
LOAD LA4-CVPAPER	Load LA4-size color paper.	Load LA4-size color paper.	<None>/interact
LOAD LA4-CVTRANS	Load LA4-size transparencies.	Load LA4-size transparencies.	<None>/interact
LOAD XLA-SIZE	Load XLA-size media.	Load XLA-size media.	<None>/interact
LOAD XLA-DVPAPER	Load XLA-size black and white paper.	Load XLA-size black and white paper.	<None>/interact
LOAD XLA-CVPAPER	Load XLA-size color paper.	Load XLA-size color paper.	<None>/interact
LOAD XLA-CVTRANS	Load XLA-size transparencies.	Load XLA-size transparencies.	<None>/interact

Printer Status Infos: Additional Codonics infos			
Printer Status info	Description	Message string visible in the Status Bar	Other action for <i>syngo</i> /camera symbol
LOAD XLA4-SIZE	Load XLA4-size media.	Load XLA4-size media.	<None>/interact
LOAD XLA4-DVPAPE	Load XLA4-size black and white paper.	Load XLA4-size black and white paper.	<None>/interact
LOAD XLA4-CVPAPE	Load XLA4-size color paper.	Load XLA4-size color paper.	<None>/interact
LOAD XLA4-CVTRAN	Load XLA4-size transparencies.	Load XLA4-size transparencies.	<None>/interact
LOAD XLW-SIZE	Load XLW-size media.	Load XLW-size media.	<None>/interact
LOAD XLW-DVPAPER	Load XLW-size black and white paper.	Load XLW-size black and white paper.	<None>/interact
LOAD XLW-CVPAPER	Load XLW-size color paper.	Load XLW-size color paper.	<None>/interact
LOAD 8X10-SIZE	Load 8x10 media.	Load 8x10 media.	<None>/interact
LOAD 8X10-DVFILM	Load 8x10 black and white film.	Load 8x10 black and white film.	<None>/interact
SUPPLY MISSING	The film supply magazine specified for this job is not available.	Film supply not available.	<None>/interact
RIBBON MISSING	Ribbon is missing.	Ribbon is missing.	<None>/interact
RIBBON EMPTY	Ribbon is empty.	Ribbon is empty.	<None>/interact



Printer Status Infos: Additional Codonics infos			
Printer Status info	Description	Message string visible in the Status Bar	Other action for <i>syngo</i> /camera symbol
TOP COVER OPEN	Top cover of printer is open.	Top cover of camera is open.	<None>/interact

Additional DICOM Execution Status Information - evaluation.



Additional DICOM Execution Status Infos			
Execution Status info	Description	Message string visible in the Status Bar	Other action for <i>syngo</i> /camera symbol
INVALID PAGE DES	The specified page layout cannot be printed or other page description errors have been detected.	Film Job cannot be printed on this camera. Queue stopped. Please redirect film job.	Queue for this camera will be STOPPED/queue stopped
INSUFFIC MEMORY	There is not enough memory available to complete this job.	Not enough memory available in camera. Queue stopped. Please continue queue or change camera.	Queue for this camera will be STOPPED/queue stopped
NONE	General printer warning, no specific information is available. Spooling of print jobs to disk is still possible.	-	<None>/idle

Additional DICOM Execution Status Information

Printer Status Info and Execution Status Info are defined terms and can therefore be extended or reduced by camera manufacturers. Therefore *syngo* shall be flexible.



If any other printer status info or execution status info is received, *syngo* will react as shown in the following table:

Printer Status/Execution	Printer Execution Status Info	Description	Message string visible in the Status Bar	Other action for <i>syngo</i> /camera symbol
WARNING	<any other>	<not defined status info>	Camera info: <status info>	<None>/interact
FAILURE	<any other>	<not defined status info>	Camera info: <status info> Queue stopped.	Queue for this camera will be STOPPED/Queue stopped

Modality Worklist AE Specification

The Modality Worklist SCU (patient registration in conjunction with the network application) requests that the remote SCP performs a match of all keys specified in the query against the information in its worklist database.

SIEMENS Somaris/5 DICOM implementation provides Standard Conformance to the following DICOM V3.0 SOP Class as an SCU:

SOP Class Name	SOP Class UID
Modality Worklist Information Model - FIND	1.2.840.10008.5.1.4.31

Association Establishment Policies

General

It is possible to configure a cyclic update of the modality scheduler database through a background worklist request with date/time and modality information.

In addition the user can request worklist update with "Update Worklist". No duplicate entries will be added in the Scheduler DB. Entries are uniquely identified by the Study Instance UID (0020,000D) for the Requested Procedure and the SPS ID (0040,0009) in the SPS Sequence (0040,0100).

An interactive worklist query can be issued with search criteria entered in the patient based Query dialog from the patient browser.

The default PDU size used will be 28 KB.

Number of Associations

The Somaris/5 DICOM application initiates one association at a time to query worklist entry data.

Asynchronous Nature

The Somaris/5 DICOM implementation does not support asynchronous communication (multiple outstanding transactions over a single association).

Implementation Identifying Information

The Somaris/5 DICOM implementation provides the Implementation Class UID of

❑ "1.3.12.2.1107.5.1.4"

and an Implementation Version Name of

❑ "SIEMENS_S5VB41A".

Association Initiation Policy

The network application will (if configured) query the worklist periodically or by user request. Ever then it establishes an association by using the DICOM association services. During association establishment the negotiation of SOP classes to exchange the capabilities of the SCU and the SCP is not supported.

The following DIMSE-C operation is supported as SCU:

- C-FIND

Real-World Activity

Associated Real-World Activity - Query (Update) Worklist

A network application will perform worklist queries with the C-FIND request at regular intervals. In addition it can be triggered by immediate request. The received worklist items will be compared with the contents of the local scheduler database. New items will be inserted into scheduler database.

After each broad query all RP/SPS that were cancelled or rescheduled to another modality at the RIS will be automatically removed from the scheduler DB if

- the Examination of this procedure has not been started or finished yet
- the corresponding configuration item "Automatic removal of cancelled/rescheduled Request" was checked in the Service UI under DICOM / HIS/RIS Node

No automatic clean-up of the scheduler DB is performed after a Patient based Query since the worklist received does not give the complete list of all currently scheduled procedures for the modality.

Proposed Presentation Contexts - Query (Update) Worklist

The Somaris/5 DICOM application will propose Presentation Contexts as shown in the following table:

Proposed presentation contexts					
Abstract Syntax		Transfer Syntax		Role	Extended Negotiation
Name	UID	Name List	UID List		
Modality Worklist Information Model - FIND	1.2.840.10008.5.1.4.31	Implicit VR Little Endian	1.2.840.10008.1.2	SCU	None
		Explicit VR Little Endian	1.2.840.10008.1.2.1		
		Explicit VR Big Endian	1.2.840.10008.1.2.2		

SOP Specific Conformance Statement - Update Worklist*Search Key Attributes of the Worklist C-FIND*

The Somaris/5 DICOM worklist SCU supports "broad worklist queries" with all required search keys.

The following tables describe the "broad query" search keys that the SCU supports, which is a query for all tasks scheduled for the own modality or own modality application entity defined with the following search keys:

Search Key Attributes in a broad worklist query			
Attribute name ^a	Tag	Matching Key Type	Query value
Scheduled Procedure Step			
Scheduled Procedure Step Sequence	(0040,0100)	R	
> Scheduled Station AE Title	(0040,0001)	R	Configurable ^b : own AET or "*"
> Scheduled Procedure Step Start Date	(0040,0002)	R	Configurable: inserted in UI ^c or n days before to m days after today
> Scheduled Procedure Step Start Time	(0040,0003)	R	Configurable: inserted in UI ^d or 0:00-23:59
> Modality	(0008,0060)	R	Configurable ^b : own modality or "*"

a. No other attributes of Register Dialog used for C-FIND

b. One and only one of the attributes "Modality" and "AE Title" is set to "*". There is a configuration parameter telling which of them. The other one is always set to the "own" value (i.e. own modality respectively own AE Title).

c. <startDate>-<endDate>

d. <startTime>-<endTime>

Note

Since various SCP implementations depend on the Specific Character Set attribute to be sent with the C-FIND in order to deliver the attribute filled with the C-FIND-RSP (see below), as a default the attribute will be sent even if empty. In case this turns out to be a problem for a specific SCP in cooperation with Siemens this can be configured not to include this attribute.

Return Key Attributes of the Worklist C-FIND-RSP

The Somaris/5 DICOM worklist SCU supports worklist queries with return key attributes of all types. The following tables describe the return keys that the SCU supports.

An "x" in the UI column will indicate that the attribute is visualized when browsing the Worklist results with Patient Browser and/or during Patient Registration. The Patient Browser display is additionally influenced by the related Browser configuration.

A tag in the IOD column will indicate that the related attribute is included into the SOP Instances of the IODs created during processing of this worklist request.

A tag in the MPPS column will indicate that the related attribute is included into the SOP Instances of the MPPS objects created during processing of this worklist request. (See also the table → page A.2–148 and → page A.2–153).

Attribute name	Tag	Return Key Type	UI	IOD	MPPS
SOP Common					
Specific Character Set ^a	(0008,0005)	1C	-	(0008,0005)	(0008,0005)
Scheduled Procedure Step					
Scheduled Procedure Step Sequence	(0040,0100)	1			
> Modality	(0008,0060)	1	x	(0008,0060)	(0008,0060)
> Requested Contrast Agent	(0032,1070)	2C	x	(0032,1070)	
> Scheduled Station AE Title	(0040,0001)	1	x		(0040,0241)
> Scheduled Procedure Step Start Date	(0040,0002)	1	x		
> Scheduled Procedure Step Start Time	(0040,0003)	1	x		
> Scheduled Procedure Step End Date	(0040,0004)	3	-		
> Scheduled Procedure Step End Time	(0040,0005)	3	-		
> Scheduled Performing Physician's Name	(0040,0006)	1	x	(0008,1050)	(0008,1050)
> Scheduled Procedure Step Description	(0040,0007)	1C	x	(0040,0007) (0040,0254)	(0040,0007) (0040,0254)
> Scheduled Protocol Code Sequence	(0040,0008)	1C	-	(0040,0008) (0040,0260)	(0040,0008) (0040,0260)
>> Code Value	(0008,0100)	1C	x		
>> Coding Scheme Designator	(0008,0102)	1C	x		
>> Coding Scheme Version	(0008,0103)	3	x		
>> Code Meaning	(0008,0104)	3	x		

Attribute name	Tag	Return Key Type	UI	IOD	MPPS
> Scheduled Procedure Step ID	(0040,0009)	1	x	(0040,0009) (0040,0253)	(0040,0009) (0040,0253)
> Scheduled Station Name	(0040,0010)	2	x		
> Scheduled Procedure Step Location	(0040,0011)	2	x		(0040,0242)
> Pre-Medication	(0040,0012)	2C	x		
> Scheduled Procedure Step Status	(0040,0020)	3	x		
> Comments on the Scheduled Procedure Step	(0040,0400)	3	-		
Requested Procedure					
Referenced Study Sequence	(0008,1110)	2	-	(0008,1110)	(0008,1110)
> Referenced SOP Class UID	(0008,1150)	1C	-		
> Referenced SOP Instance UID	(0008,1155)	1C	-		
Study Instance UID	(0020,000D)	1	-	(0020,000D)	(0020,000D)
Requested Procedure Description	(0032,1060)	1C	x	(0032,1060)	(0032,1060)
Requested Procedure Code Sequence	(0032,1064)	1C	-	(0032,1032) (0032,1064)	(0032,1032)
> Code Value	(0008,0100)	1C	x		
> Code Scheme Designator	(0008,0102)	1C	x		
> Code Scheme Version	(0008,0103)	3	x		
> Code Meaning	(0008,0104)	3	x		
Requested Procedure ID	(0040,1001)	1	x	(0040,1001) (0020,0010)	(0040,1001) (0020,0010)

Attribute name	Tag	Return Key Type	UI	IOD	MPPS
Reason for the Requested Procedure	(0040,1002)	3	-		
Requested Procedure Priority	(0040,1003)	2	x		
Patient Transport Arrangements	(0040,1004)	2	-		
Requested Procedure Location	(0040,1005)	3	-		
Confidentiality Code	(0040,1008)	3	-		
Reporting Priority	(0040,1009)	3	-		
Names of Intended Recipients of results	(0040,1010)	3	-	(0008,1048)	
Requested Procedure Comments	(0040,1400)	3	x		
Imaging Service Request					
Accession Number	(0008,0050)	2	x	(0008,0050)	(0008,0050)
Referring Physician's Name	(0008,0090)	2	x	(0008,0090)	
Requesting Physician	(0032,1032)	2	x	(0032,1032)	(0032,1032)
Requesting Service	(0032,1033)	3	x	(0032,1033)	
Reason for the Imaging Service Request	(0040,2001)	3	-		
Issuing Date of Imaging Service Request	(0040,2004)	3	-		
Issuing Time of Imaging Service Request	(0040,2005)	3	-		
Placer Order Number / Imaging Service Request	(0040,2016)	3	-		(0040,2016)

Attribute name	Tag	Return Key Type	UI	IOD	MPPS
Filler Order Number / Imaging Service Request	(0040,2017)	3	-		(0040,2017)
Order entered by...	(0040,2008)	3	-		
Order Enterer's Location	(0040,2009)	3	-		
Order Callback Phone Number	(0040,2010)	3	-		
Imaging Service Request Comments	(0040,2400)	3	x		
Visit Identification					
Institution Name	(0008,0080)	3	x	(0008,0080)	
Institution Address	(0008,0081)	3	-	(0008,0081)	
Institution Code Sequence	(0008,0082)	3	-		
> Code Value	(0008,0100)	1C			
> Code Scheme Designator	(0008,0102)	1C			
> Code Scheme Version	(0008,0103)	3			
> Code Meaning	(0008,0104)	3			
Admission ID	(0038,0010)	2	x		
Issuer of Admission ID	(0038,0011)	3	-		
Visit Status					
Visit Status ID	(0038,0008)	3	-		
Current Patient Location	(0038,0300)	2	x		
Patient's Institution Residence	(0038,0400)	3	-		
Visit Comments	(0038,4000)	3	-		

Attribute name	Tag	Return Key Type	UI	IOD	MPPS
Visit Relationship					
Referenced Study Sequence	(0008,1110)	3	-		
> Referenced SOP Class UID	(0008,1150)	1C	-		
> Referenced SOP Instance UID	(0008,1155)	1C	-		
Referenced Patient Sequence	(0008,1120)	2	-		(0008,1120)
> Referenced SOP Class UID	(0008,1150)	1C	-		
> Referenced SOP Instance UID	(0008,1155)	1C	-		
Visit Admission					
Referring Physician's Name	(0008,0090)	2	x	(0008,0090)	
Referring Physician's Address	(0008,0092)	3	-		
Referring Physician's Phone Numbers	(0008,0094)	3	-		
Admitting Diagnoses Description	(0008,1080)	3	x	(0008,1080)	
Admitting Diagnosis Code Sequence	(0008,1084)	3			
> Code Value	(0008,0100)	1C			
> Code Scheme Designator	(0008,0102)	1C			
> Code Scheme Version	(0008,0103)	3			
> Code Meaning	(0008,0104)	3			
Route of Admissions	(0038,0016)	3	-		
Admitting Date	(0038,0020)	3	-		
Admitting Time	(0038,0021)	3	-		

Attribute name	Tag	Return Key Type	UI	IOD	MPPS
Patient Identification					
Patient’s Name	(0010,0010)	1	x	(0010,0010)	(0010,0010)
Patient ID	(0010,0020)	1	x	(0010,0020)	(0010,0020)
Issuer of Patient ID	(0010,0021)	3	-	(0010,0021)	
Other Patient IDs	(0010,1000)	3	x	(0010,1000)	
Other Patient Names	(0010,1001)	3	x	(0010,1001)	
Patient’s Birth Name	(0010,1005)	3	-	(0010,1005)	
Patient’s Mother’s Birth Name	(0010,1060)	3	-	(0010,1060)	
Medical Record Locator	(0010,1090)	3	-	(0010,1090)	
Patient Demographic					
Patients Birth Date	(0010,0030)	2	x	(0010,0030)	(0010,0030)
Patients Birth Time	(0010,0032)	3	-	(0010,0032)	
Patient’s Sex	(0010,0040)	2	x	(0010,0040)	(0010,0040)
Patient’s Insurance Plan Code Sequence	(0010,1050)	3	-	(0010,1050)	
> Code Value	(0008,0100)	1C			
> Code Scheme Designator	(0008,0102)	1C			
> Code Scheme Version	(0008,0103)	3			
> Code Meaning	(0008,0104)	3			
Patient’s Age	(0010,1010)	3	x	(0010,1010)	
Patient’s Size	(0010,1020)	3	x	(0010,1020)	
Patient’s Weight	(0010,1030)	2	x	(0010,1030)	
Patient’s Address	(0010,1040)	3	x	(0010,1040)	

Attribute name	Tag	Return Key Type	UI	IOD	MPPS
Military Rank	(0010,1080)	3	x	(0010,1080)	
Branch of Service	(0010,1081)	3	-	(0010,1081)	
Country of Residence	(0010,2150)	3	-	(0010,2150)	
Region of Residence	(0010,2152)	3	-	(0010,2152)	
Patient's Telephone Numbers	(0010,2154)	3	-	(0010,2154)	
Ethnic Group	(0010,2160)	3	x	(0010,2160)	
Occupation	(0010,2180)	3	-	(0010,2180)	
Patient's Religious Preference	(0010,21F0)	3	-	(0010,21F0)	
Patient Comments	(0010,4000)	3	x	(0010,4000)	
Patient Data Confidentiality Constraint Description	(0040,3001)	2	x	(0040,3001)	
Patient Medical					
Medical Alerts	(0010,2000)	2	x	(0010,2000)	
Contrast Allergies	(0010,2110)	2	x	(0010,2110)	
Pregnancy Status	(0010,21C0)	2	x	(0010,21C0)	
Smoking Status	(0010,21A0)	3	x	(0010,21A0)	
Last Menstrual Date	(0010,21D0)	3	x	(0010,21D0)	
Additional Patient History	(0010,21B0)	3	x	(0010,21B0)	
Special Needs	(0038,0050)	2	x	(0038,0050)	
Patient State	(0038,0500)	2	x	(0038,0500)	
Patient Relationship					
Referenced Study Sequence	(0008,1110)	3	-		
> Referenced SOP Class UID	(0008,1150)	1C	-		



Attribute name	Tag	Return Key Type	UI	IOD	MPPS
> Referenced SOP Instance UID	(0008,1155)	1C	-		
Referenced Visit Sequence	(0008,1125)	3	-		
> Referenced SOP Class UID	(0008,1150)	1C	-		
> Referenced SOP Instance UID	(0008,1155)	1C	-		
Referenced Patient Alias Sequence	(0038,0004)	3	-		
> Referenced SOP Class UID	(0008,1150)	1C	-		
> Referenced SOP Instance UID	(0008,1155)	1C	-		

- a. The Specific Character Set distributed via Modality Worklist by the hospital network shall reflect the global hospital context, e.g. a hospital with german context shall not restrict the worklist entries to ISO_IR 6 but supply a character set adequate to hold all german language text input.

Associated Real-World Activity - Get Worklist

With "Get Worklist" in the patient based Worklist Query dialog the entered attributes are used to form a worklist request identifier. With the response data the Patient Registration dialog can be updated to perform examination in advance. The response data are additionally placed in the scheduler database.

Proposed Presentation Contexts - Get Worklist

The same Presentation contexts as with "Update Worklist" will be proposed.

SOP Specific Conformance - Get Worklist

Search Key Attributes of the Worklist C-FIND

The Somaris/5 DICOM worklist SCU supports "narrow worklist queries" with all required search keys.

The following table describes the search keys that the SCU supports for a patient based worklist query, which is defined by the following search keys

Attribute name	Tag	Matching Key Type	Query value
Scheduled Procedure Step			
Scheduled Procedure Step Sequence	(0040,0100)	R	
> Scheduled Performing Physician's Name	(0040,0006)	R	inserted in UI or zero length
Requested Procedure			
Requested Procedure ID	(0040,1001)	O	inserted in UI or zero length
Imaging Service Request			
Accession Number	(0008,0050)	O	inserted in UI or zero length
Referring Physician's Name	(0008,0090)	O	inserted in UI or zero length
Visit Status			



Attribute name	Tag	Matching Key Type	Query value
Current Patient Location	(0038,0300)	O	inserted in UI or zero length
Patient Identification			
Patient’s Name	(0010,0010)	R	inserted in UI or zero length
Patient ID ^a	(0010,0020)	R	inserted in UI or zero length

a. Please be aware that although in the UI there are different entries for First Name and Last Name of a patient these are combined into one query attribute. Querying just for the Last Name (without wildcard) or not providing a first letter for the First Name may prevent expected matches.

Return Key Attributes used from the Worklist C-FIND-RSP

Please see table → page A.2–134.

Status Codes of the Worklist C-FIND

The worklist SCU interprets following status codes:

Service Status	Meaning	Status Codes (0000,0900)	Related Fields
Refused	Out of Resources	A700	(0000,0902)
Failed	Identifier does not match SOP Class	A900	(0000,0901) (0000,0902)
	Unable to process	Cxxx	(0000,0901) (0000,0902)
Cancel	Matching terminated due to Cancel request	FE00	None
Success	Matching is complete - No final Identifier is supplied	0000	None



Service Status	Meaning	Status Codes (0000,0900)	Related Fields
Pending	Matches are continuing - Current Match is supplied and any Optional Keys were supported in the same manner as Required Keys	FF00	Identifier
	Matches are continuing - Warning that one or more Optional Keys were not supported for existence and/or matching for this identifier	FF01	Identifier

Modality Performed Procedure Step AE Specification

The Modality Performed Procedure Step SCU (Patient Registration and MPPS UI) provide information about a performed real-world Procedure to a remote SCP (Information System).

SIEMENS Somaris/5 DICOM implementation provides Standard Conformance to the following DICOM V3.0 SOP Class as an SCU:

SOP Class Name	SOP Class UID
Modality Performed Procedure Step	1.2.840.10008.3.1.2.3.3

Association Establishment Policies

General

The creation of a MPPS Instance is done automatically by the Somaris/5 DICOM application whenever a patient is registered for image acquisition through the Patient Registration dialog. Exception: In case of Emergency Patients the MPPS is created only when the user explicitly sends a corresponding message from the MPPS user interface.

Further updates on the MPPS data can be done interactively from the related MPPS user interface. The MPPS "Complete" or "Discontinued" states can only be set from user interface.

The default PDU size used will be 28 KB.

Number of Associations

The Siemens DICOM application initiates one association at a time to create or set MPPS instance.

Asynchronous Nature

The Siemens DICOM software does not support asynchronous communication (multiple outstanding transactions over a single association).

Implementation Identifying Information

The Siemens DICOM software provides the Implementation Class UID of

❑ "1.3.12.2.1107.5.1.4"

and an Implementation Version Name of

❑ "SIEMENS_S5VB41A".

Association Initiation Policy

The Somaris/5 DICOM Application Entity acts as a Service Class User (SCU) for the

Modality Performed Procedure Step Service Class (to notify a RIS about status of a procedure while it is performed).

To do so, it will issue a:

- N-CREATE DIMSE according to the CREATE Modality Performed Procedure Step SOP Instance operation or a
- N-SET DIMSE to update the contents and state of the MPPS according to the SET Modality Performed Procedure Step Information operation

Real World Activity

Associated Real-World Activity - Patient Registered

The associated Real-World activity is to send examination information to an SCP by using the DICOM Modality Performed Procedure Step Service.

Proposed Presentation Contexts - Patient Registered

The Siemens DICOM application will propose Presentation Contexts as shown in the following table:

Presentation Context Table

Name	Abstract Syntax	Transfer Syntax		Role	Extended Negotiation
	UID	Name List	UID List		
Modality Performed Procedure Step	1.2.840.10008.3.1.2.3.3	Implicit VR Little Endian	1.2.840.10008.1.2	SCU	None
		Explicit VR Little Endian	1.2.840.10008.1.2.1		
		Explicit VR Big Endian	1.2.840.10008.1.2.2		

SOP Specific Conformance Statement - Patient Registered

Attributes used for the Performed Procedure Step N-CREATE

The Siemens DICOM Modality Performed Procedure Step SCU informs the remote SCP when the examination of a scheduled procedure step will be performed (i.e. the patient is registered). The N-CREATE message is sent when the examination is started with successful registration of patient data. The following table describes the supported attributes for a N-CREATE message.

Performed Procedure Step N-CREATE Attributes			
Attribute name	Tag	Required Type	Value
SOP Common			
Specific Character Set	(0008,0005)	1C	from MWL or created
Performed Procedure Step Relationship			
Scheduled Step Attribute Sequence	(0040,0270)	1	
> Study Instance UID	(0020,000D)	1	from MWL or created
> Referenced Study Sequence	(0008,1110)	2	from MWL or zero length
>> Referenced SOP Class UID	(0008,1150)	1C	
>> Referenced SOP Instance UID	(0008,1155)	1C	
> Accession Number	(0008,0050)	2	from MWL or user input
> Placer Order Number / Imaging Service Request	(0040,2016)	3	from MWL or zero length
> Filler Order Number / Imaging Service Request	(0040,2017)	3	from MWL or zero length
> Requested Procedure ID	(0040,1001)	2	from MWL or user input
> Requested Procedure Description	(0032,1060)	2	from MWL or zero length



Performed Procedure Step N-CREATE Attributes			
Attribute name	Tag	Required Type	Value
> Scheduled Procedure Step ID	(0040,0009)	2	from MWL or zero length
> Scheduled Procedure Step Description	(0040,0007)	2	from MWL or zero length
> Scheduled Protocol Code Sequence	(0040,0008)	2	from MWL or zero length
>> Code Value	(0008,0100)	1C	
>> Coding Scheme Designator	(0008,0102)	1C	
>> Code Scheme Version	(0008,0103)	3	
>> Code Meaning	(0008,0104)	3	
Patient's Name	(0010,0010)	2	from MWL or user input
Patient ID	(0010,0020)	2	from MWL or user input or created
Patients Birth Date	(0010,0030)	2	from MWL or user input
Patient's Sex	(0010,0040)	2	from MWL or user input
Referenced Patient Sequence	(0008,1120)	2	from MWL or zero length
> Referenced SOP Class UID	(0008,1150)	1C	
> Referenced SOP Instance UID	(0008,1155)	1C	
Performed Procedure Step Information			
Performed Procedure Step ID	(0040,0253)	1	from SPS ID or created
Performed Station AE Title	(0040,0241)	1	own AE Title
Performed Station Name	(0040,0242)	2	own hostname

Performed Procedure Step N-CREATE Attributes

Attribute name	Tag	Required Type	Value
Performed Location	(0040,0243)	2	from SPS Location or zero length
Performed Procedure Step Start Date	(0040,0244)	1	created
Performed Procedure Step Start Time	(0040,0245)	1	created
Performed Procedure Step Status	(0040,0252)	1	IN PROGRESS
Performed Procedure Step Description	(0040,0254)	2	from SPS Description or zero length
Performed Procedure Type Description	(0040,0255)	2	zero length
Procedure Code Sequence	(0008,1032)	2	from Requested Procedure Code or zero length
> Code Value	(0008,0100)	1C	
> Code Scheme Designator	(0008,0102)	1C	
> Code Scheme Version	(0008,0103)	3	
> Code Meaning	(0008,0104)	3	
Performed Procedure Step End Date	(0040,0250)	2	zero length
Performed Procedure Step End Time	(0040,0251)	2	zero length
Image Acquisition Results			
Modality	(0008,0060)	1	CT
Study ID	(0020,0010)	2	from Requested Procedure ID or created
Performed Protocol Code Sequence	(0040,0260)	2	from Scheduled Protocol Code SQ or zero length



Performed Procedure Step N-CREATE Attributes

Attribute name	Tag	Required Type	Value
> Code Value	(0008,0100)	1C	
> Code Scheme Designator	(0008,0102)	1C	
> Code Scheme Version	(0008,0103)	3	
> Code Meaning	(0008,0104)	3	
Performed Series Sequence	(0040,0340)	2	
> Performing Physicians’s Name	(0008,1050)	2C	from MWL or user input
> Protocol Name	(0008,1030)	1C	default value
> Operator’s Name	(0008,1070)	2C	user input
> Series Instance UID	(0020,000E)	1C	created
> Series Description	(0008,103E)	2C	zero length
> Retrieve AE Title	(0008,0054)	2C	zero length
> Referenced Image Sequence	(0008,1140)	2C	zero length
> Referenced Standalone SOP Instance Sequence	(0040,0220)	2C	zero length

Status Codes of the Performed Procedure Step N-CREATE

The Performed Procedure Step SCU interprets the following status values:

N-SET Response Status		
Service Status	Meaning	Status Codes (0000,0900)
Failure	Processing Failure	0110
	No such attribute	0105
	Invalid attribute value	0106
	Duplicate SOP Instance	0111
	No such SOP Instance	0112
	No such SOP class	0118
	Class instance conflict	0119
	Missing attribute	0120
	Missing attribute value	0121
	Resource limitation	0213
Success	Successful Operation	0000

Associated Real-World Activity - Update

The associated Real-World activity is to send examination information to an SCP by using the DICOM Modality Performed Procedure Step Service either implicitly (examination) or explicitly (MPPS UI).

Proposed Presentation Contexts - Update

The same Presentation Contexts as in → page A.2–147 will be proposed.

SOP Specific Conformance Statement - Update

Attributes used for the Performed Procedure Step N-SET

The Somaris/5 DICOM performed procedure step SCU informs the remote SCP about the performed examination and its status. The N-Set message is sent once for each reconstruction of acquisition data with status "IN_PROGRESS". The N-SET message is sent on user input with status "COMPLETED" or "DISCONTINUED", respectively. This is intended to be used when the examination is finished with status "COMPLETED" or when the examination could not be completed with status "DISCONTINUED" (already sent automatically when examination is ended via End Exam and no acquisition was done). The following table describes the supported attributes for a N-SET message.

Performed Procedure Step N-SET Attributes			
Attribute name	Tag	Required Type	Value
Performed Procedure Step Information			
Performed Procedure Step Status	(0040,0252)	3	IN_PROGRESS or COMPLETED or DISCONTINUED (see above)
Performed Procedure Step Description	(0040,0254)	3	from SPS Description or user input
Performed Procedure Type Description	(0040,0255)	3	zero length
Procedure Code Sequence	(0008,1032)	3	from Requested Procedure Code or empty on user change (see IHE Technical Framework Y3, App. C Note 6)
> Code Value	(0008,0100)	1C	
> Code Scheme Designator	(0008,0102)	1C	



Performed Procedure Step N-SET Attributes			
Attribute name	Tag	Required Type	Value
> Code Scheme Version	(0008,0103)	1C	
> Code Meaning	(0008,0104)	1C	
Performed Procedure Step End Date	(0040,0250)	3	created or zero length
Performed Procedure Step End Time	(0040,0251)	3	created or zero length
Image Acquisition Results			
Performed Protocol Code Sequence	(0040,0260)	3	from Scheduled Protocol Code SQ or user input
> Code Value	(0008,0100)	1C	
> Code Scheme Designator	(0008,0102)	1C	
> Code Scheme Version	(0008,0103)	1C	
> Code Meaning	(0008,0104)	1C	
Performed Series Sequence	(0040,0340)	1	
> Performing Physicians's Name	(0008,1050)	2C	from MWL or user input [empty if Study Split is used]
> Protocol Name	(0018,1030)	1C	name of Scan Protocol (Siemens standard or user defined) [dummy if Study Split is used]
> Operator's Name	(0008,1070)	2C	user input [empty if Study Split is used]



Performed Procedure Step N-SET Attributes			
Attribute name	Tag	Required Type	Value
> Series Instance UID	(0020,000E)	1C	created [dummy if Study Split is used]
> Series Description	(0008,103E)	2C	range name with generated reconstruction information or user input [empty if Study Split is used]
> Retrieve AE Title	(0008,0054)	2C	from Storage Commitment RSP or zero length
> Referenced Image Sequence	(0008,1140)	2C	created [empty if Study Split is used]
>> Referenced SOP Class UID	(0008,1150)	1C	
>> Referenced SOP Instance UID	(0008,1155)	1C	
> Referenced Standalone SOP Instance Sequence	(0040,0220)	2C	zero length
Radiation Dose			
Total Number of Exposures	(0040,0301)	3	created (number of scans)
Distance Source to Detector (SID)	(0018,1110)	3	created
Distance Source to Entrance	(0040,0306)	3	created
Comments on Radiation Dose	(0040,0310)	3	created (one line per scan) ^a



Performed Procedure Step N-SET Attributes			
Attribute name	Tag	Required Type	Value
Billing and Material Management Code			
Film Consumption Sequence	(0040,0321)	3	created or zero length
> Number of Films	(2100,0170)	3	
> Medium Type	(2000,0030)	3	
> Film Size ID	(2010,0050)	3	
Billing Supplies and Devices Sequence	(0040,0324)	3	user input in Examination Card (example values below) or MPPS window
> Billing Item Sequence	(0040,0296)	3	
>> Code Value	(0008,0100)	1C	e.g. contrast media code
>> Code Scheme Designator	(0008,0102)	1C	e.g. contrast media catalog
>> Code Meaning	(0008,0104)	1C	e.g. contrast media name
> Quantity Sequence	(0040,0293)	1C	
>> Quantity	(0040,0294)	3	e.g. volume of contrast media
>> Measuring Units Sequence	(0040,0295)	3	
>>> Code Value	(0008,0100)	1C	e.g. cm3
>>> Code Scheme Designator	(0008,0102)	1C	e.g. UCUM
>>> Code Scheme Version	(0008,0103)	1C	e.g. 1.4



Performed Procedure Step N-SET Attributes

Attribute name	Tag	Required Type	Value
>>> Code Meaning	(0008,0104)	1C	e.g. cm3

a. The following format is used:

RangeName: kV=xxx mAs=xxx CTDIvol=xxx DLP=xxx
CTDIvol and DLP is not provided for Topogram scans.

Status Codes of the Performed Procedure Step N-SET

The Performed Procedure Step SCU interprets the following status values:

N-SET Response Status		
Service Status	Meaning	Status Codes (0000,0900)
Failure	Processing Failure: Performed Procedure Step Object may no longer be updated	0110
	No such attribute	0105
	Invalid attribute value	0106
	No such SOP Instance	0112
	Invalid object instance	0117
	No such SOP class	0118
	Class instance conflict	0119
	Missing attribute value	0121
	Resource limitation	0213
Success	MPPS instance set	0000

Supported Communication Stacks

The Somaris/5 DICOM application provides DICOM V3.0 TCP/IP Network Communication Support as defined in Part 8 of the DICOM Standard.

The product target operating system is Windows XP.

OSI Stack

Not supported.

TCP/IP Stack

The Somaris/5 DICOM application uses the TCP/IP stack from the Windows XP system. It uses the MergeCOM-3 subroutine library from Merge Technologies Inc. that is based on a Berkeley socket interface.

API

The Somaris/5 DICOM application uses the MergeCOM library that is based on a TCP/IP socket interface.

Physical Media Support

The Somaris/5 DICOM application is indifferent to the physical medium over which TCP/IP executes. It inherits it from the target operating system upon which it executes.

Point-to-Point Stack

Not supported.



Standard Extensions

Standard Extensions of all SOP Classes

The following tables list the data dictionary of all DICOM IOD attributes where the DICOM standard definitions are extended:

All SOP classes may contain additional type 3 attributes which DICOM standard defines in a different DICOM IOD or DICOM SOP class (attributes from Normalized SOP classes).

This is the case for example for

- Rescale Slope (0028,1053)
- Rescale Intercept (0028,1052)

which are also used in the MR IOD.

Image Type

The Image Type (0008,0008) attribute identifies important image identification characteristics. These characteristics are:

1. Pixel Data Characteristics:
 - Is the image an ORIGINAL Image; an image whose pixel values are based on original or source data, or
 - is the image a DERIVED Image; an image whose pixel values have been derived in some manner from the pixel value of one or more other images.
2. Patient Examination Characteristics:
 - Is the image a PRIMARY Image; an image created as a direct result of the Patient examination, or
 - is the image a SECONDARY Image; an image created after the initial Patient examination.
3. Modality Specific Characteristics (SOP Specific Characteristics).
4. Implementation specific identifiers; other implementation specific identifiers shall be documented in an implementation's conformance claim.

The Image Type attribute is multi-valued and shall be provided in the following manner:

- Value 1 shall identify the Pixel Data Characteristics;
Enumerated Values for the Pixel Data Characteristics are:
 - ORIGINAL = identifies an Original Image
 - DERIVED = identifies a Derived Image
- Value 2 shall identify the Patient Examination Characteristics;
Enumerated Values for the Patient Examination Characteristics are:
 - PRIMARY = identifies a Primary Image
 - SECONDARY = identifies a Secondary Image
- Value 3 shall identify any Image IOD specific specialization, the following terms are defined in addition to the DICOM standard definitions:
 - OTHER = converted non-Axial and non-Localizer CT images; images of no special type (new syntax)
 - MPR = 3D MPR images (MR)

- ❑ PROJECTION IMAGE = 3D MIP and SSD images (MR)
- ❑ UNDEFINED = images of no special type (old syntax)
- ❑ **Value 4** is implementation specific. The following terms are defined:

original *syngo* generated data set types:

CSA 3D EDITOR = object created by 3D Editor

CSA 3D FLY PATH = object created by Fly Through Path

CSA 3D FLY VRT = object created by Fly Through Volume Rendering Technique

CSA 3D FUSION = object created by Fusion

CSA AVERAGE = image was created by Average

CSA BLACK IMAGE = SC Image with black pixels, only graphics information is of interest

CSA BOOKMARK = InSpace generated SC image containing bookmark information

CSA RESAMPLED = derived image created by zooming or panning original image

CSA REPORT = syngo Reporting (documentation of diagnosis)

CSA RESULT = syngo Reporting (post processing results)

CSA MIP = image created by Maximum Intensity Projection

CSA MIP THIN = image created by Maximum Intensity Projection

CSA MIP THIN CV = image created by Maximum Intensity Projection (curved cut)

CSA MPR = image created by Multi Planar Reconstruction

CSA MPR CV = image created by Multi Planar Reconstruction (curved cut)

CSA MPR THICK = image created by Multi Planar Reconstruction

CSA MPR THICK CV = image created by Multi Planar Reconstruction (curved cut)

CSA MPR THIN = image created by Multi Planar Reconstruction

CSA PSSD = SC image as Perspective Shaded Surface Display

CSA SSD = SC Image as Shaded Surface Display

CSA SUBTRACT = image was created by Subtraction

CSA VRT = SC Image created by Volume Rendering Technique

ECAT ACF = CTI PET Attenuation Correction

ECAT NORMAL = CTI PET Normalization
ECAT 3D SINO = CTI PET 3D Sinogram Short
ECAT 3D SINO FLT = CTI PET 3D Sinogram Float

- ❑ additional image types generated by Somaris/5 or Somaris/5 based SOMATOM products:
 - CT_SOM5 AVE** = Average Image
 - CT_SOM5 ICD** = Interventional Cine Display Image
 - CT_SOM5 MON** = Monitoring Image
 - CT_SOM5 MUL** = Multiscan Image
 - CT_SOM5 PAR** = Parameter Image
 - CT_SOM5 PROT** = Protocol Image
 - CT_SOM5 ROT** = ROT Image
 - CT_SOM5 RTD** = Real Time Display Image
 - CT_SOM5 SEQ** = Sequence Image
 - CT_SOM5 SPI** = Spiral Image
 - CT_SOM5 SPO** = Spiral Oblique Image
 - CT_SOM5 STA** = Static Image
 - CT_SOM5 SUB** = Subtracted Image
 - CT_SOM5 TOP** = Topogram
 - CT_SOM5 DPAN** = Dental Panorama Rebuilt Tomogram
 - CT_SOM5 DPAR** = Dental Paraxial Rebuilt Tomogram
 - CT_SOM5 DFLM** = Dental Filming Image
 - CT_SOM5 DYB** = Dynamic Evaluation Averaged Baseline Image
 - CT_SOM5 DYF** = Dynamic Evaluation Fused Multislice Image
 - CT_SOM5 PEVI** = Pulmo Evaluation Image
 - CT_SOM5 OEVA** = Osteo Evaluated Tomogram
 - CT_SOM5 MIP** = Maximum Intensity Projection image created by a CT application
 - CT_SOM5 MPR** = Multi Planar Reconstruction image created by a CT application
 - CT_SOM5 REP** = Lung Care Report Image
- ❑ converted images
 - CT_SOM4 NONE** = converted SOMARIS image
 - CT_SOM4 CONV** = converted SOMARIS Convolution Kernel file
 - CT_SOM4 DART** = converted SOMARIS Dental Artificial image

CT_SOM4 DEVA = converted SOMARIS Dental Evaluation image
CT_SOM4 DGRA = converted SOMARIS Dental Graphics image
CT_SOM4 DMEA = converted SOMARIS Dynamic Measurement image
CT_SOM4 DPAN = converted SOMARIS Dental Panorama image
CT_SOM4 DPAR = converted SOMARIS Dental Paraxial image
CT_SOM4 EBT = converted SOMARIS Evolution image
CT_SOM4 HIS = converted SOMARIS Histogram Graphics image
CT_SOM4 HISC = converted SOMARIS Histogram Graphics image
CT_SOM4 MUL = converted SOMARIS Multiscan image
CT_SOM4 OEVA = converted SOMARIS Osteo Evaluation image
CT_SOM4 OTOM = converted SOMARIS Osteo Tomogram image
CT_SOM4 OTOP = converted SOMARIS Osteo Topogram image
CT_SOM4 PLOT = converted SOMARIS Plot image
CT_SOM4 QUAL = converted SOMARIS Quality image
CT_SOM4 R2D = converted SOMARIS 2D Rebuild image
CT_SOM4 R3D = converted SOMARIS 3D Rebuild image
CT_SOM4 R3DE = converted SOMARIS 3D Rebuild image
CT_SOM4 RMAX = converted SOMARIS Maximum Intensity Projection image
CT_SOM4 RMIN = converted SOMARIS Minimum Intensity Projection image
CT_SOM4 ROT = converted SOMARIS Rotation Mode image
CT_SOM4 RRAD = converted SOMARIS Radiographic Projection image
CT_SOM4 RVIT = converted SOMARIS Vessel Image Tool image
CT_SOM4 RVRT = converted SOMARIS Volumetric Rendering image

CT_SOM4 SAVE = converted SOMARIS Evolution Screen Save image
CT_SOM4 SCAN = converted SOMARIS Standard Mode image
CT_SOM4 SEQ = converted SOMARIS Sequence Mode image
CT_SOM4 SER = converted SOMARIS Serial Mode image
CT_SOM4 SIN = converted SOMARIS Sinogram image
CT_SOM4 SINC = converted SOMARIS Sinogram image
CT_SOM4 SPI = converted SOMARIS Spiral Mode image
CT_SOM4 STA = converted SOMARIS Static Mode image
CT_SOM4 TAB = converted SOMARIS Correction Table image
CT_SOM4 TOP = converted SOMARIS Topogram image
CT_SOM4 GTOP = converted SOMARIS Topo Graphics image
CT_SOM4 PEVG = converted SOMARIS Pulmo Evaluation image
CT_SOM4 PEVI = converted SOMARIS Pulmo Evaluation image
CT_SOM4 PUL = converted SOMARIS Pulmo Respiration curve
CT_SOM4 PROT = converted SOMARIS Protocol image
CT_SOM4 TEXT = converted SOMARIS Text image
CT_SOM4 ICD = converted SOMARIS Interventional Cine image
SHS DENT = converted MagicView Dental Tomogram image
SHS DPAN = converted MagicView Dental Panorama image
SHS DPAR = converted MagicView Dental Paraxial image
SHS 3D_CURVED = converted MagicView image
SHS 3D_MIP = converted MagicView Maximum Intensity Projection image
SHS 3D_MPR = converted MagicView Multi Planar Reconstruction image
SHS 3D_SSD = converted MagicView Shaded Surface Display image
SHS 3D_VRT = converted MagicView Volumetric Rendering image

- **Value 5** is specific for the Somaris/5 or Somaris/5 based SOMATOM products. In special cases (3D postprocessing) values mentioned for a lower index may appear for value 5 or higher. This will refer to 3D postprocessing base image types.

The following terms are defined:

ADD = Additional Scan

ALP = Arterial Liver Perfusion

CTL = Control Scan

HPI = Hepatic Perfusion Index

FINISHED = Lung Care Report Image (finished)

IN_WORK = Lung Care Report Image (not finished)

MRTD = Multiscan Real Time Display Image

OTOM = Osteo Scanned Tomogram

OTOP = Osteo Scanned Topogram

PBF = Perfusion Blood Flow Image

PBV = Perfusion Blood Volume Image

PKET = Peak Enhancement Parameter Image

PMON = Premonitoring Scan

PVP = Portal Venous Liver Perfusion

RT3D CONFIG = InSpace Configuration Image

STD = Standard image of corresponding Type 4

TTP = Time to Peak Parameter Image

TTS = Time to Start Parameter Image

Body Part Examined

The Body Part Examined (0018,0015) attribute provides a textual description of the part of the body examined. The Somaris/5 based SOMATOM products extend the Defined Terms:

- ❑ **SPINE** = Summary term used instead of the Defined Terms CSPINE, TSPINE, LSPINE, and SSPINE
- ❑ **SPECIAL** = Image was acquired with acquisition modes that are not mapped to a certain part of the body
- ❑ **SERVICE** = Image was acquired for maintenance purpose
- ❑ **UNKNOWN** = No information about the body part available

See → page A.4–21, *Structured Reports created by Somaris/5* for a mapping of the organ characteristics used for examination to the Body Part Examined terms.

In addition, the user interface permits the definition of new terms by the user. So in fact any syntactically correct value may be present as a value of this attribute. It is recommended, though, to use the DICOM defined terms when appropriate.

RGB color images

The Somaris/5 DICOM application extends the CT Image IOD by the use of RGB color image description with the unsigned integer 24 bit color image plane pixel format:

- samples per pixel (attribute 0028, 0002) = 3
- photometric interpretation (attribute 0028,0004) = "RGB"
- pixel representation (attribute 0028, 0103) = 0
- bits allocated (attribute 0028, 0100) = 8
- bits stored (attribute 0028,0101) = 8
- high bit (attribute 0028,0102) = 7
- planar configuration (attribute 0028,0006) = 0

This format is used for Functional Imaging, i.e. images that meaningfully use all common CT Image attributes - however the pixel values do not represent a scaled Hounsfield value but a different value (depending on the type of image). Thus window related attributes must not be used to interpret the pixel values as scaled HU. The values used by Somaris/5 are:

- window center (attribute 0028, 1050) = 128
- window width (attribute 0028,1051) = 256
- rescale intercept (attribute 0028, 1050) = 0
- rescale slope (attribute 0028,1051) = 1

The following types of images may use this format:

Somaris/5 Image Type (0008,0008) for objects created by Somaris/5

Image Type Description	IOD	0008,0008 Value 1	0008,0008 Value 2	0008,0008 Value 3	0008,0008 Value 4	0008,0008 Value 5	Somaris/5 Image Text
Averaged Image	CT	DERIVED	SECONDARY	AXIAL	CT_SOM5 AVE	none	AVE
Parameter Image (Patlak Blood Volume)	CT	DERIVED	SECONDARY	AXIAL	CT_SOM5 PAR	PKBV	PAR
Parameter Image (Peak enhancement)	CT	DERIVED	SECONDARY	AXIAL	CT_SOM5 PAR	PKET	PAR
Parameter Image (Perfusion Blood Flow)	CT	DERIVED	SECONDARY	AXIAL	CT_SOM5 PAR	PBF	PAR
Parameter Image (Perfusion Blood Volume)	CT	DERIVED	SECONDARY	AXIAL	CT_SOM5 PAR	PBV	PAR
Parameter Image (Permeability)	CT	DERIVED	SECONDARY	AXIAL	CT_SOM5 PAR	PMB	PAR
Parameter Image (Time to Peak)	CT	DERIVED	SECONDARY	AXIAL	CT_SOM5 PAR	TTP	PAR
Parameter Image (Time to Start)	CT	DERIVED	SECONDARY	AXIAL	CT_SOM5 PAR	TTS	PAR

Somaris/5 Image Type (0008,0008) for objects created by Somaris/5

Image Type Description	IOD	0008,0008 Value 1	0008,0008 Value 2	0008,0008 Value 3	0008,0008 Value 4	0008,0008 Value 5	Somaris/5 Image Text
Parameter Image (Patlak Residual)	CT	DERIVED	SECONDARY	AXIAL	CT_SOM5 PAR	PKER	PAR
Parameter Image (Patlak RSquare)	CT	DERIVED	SECONDARY	AXIAL	CT_SOM5 PAR	PKR2	PAR
Parameter Image (Arterial LiverPerfusion)	CT	DERIVED	SECONDARY	AXIAL	CT_SOM5 PAR	ALP	PAR
Parameter Image (Portal Venous Liver Perfusion)	CT	DERIVED	SECONDARY	AXIAL	CT_SOM5 PAR	PVP	PAR
Parameter Image (Hepatic Perfusion Index)	CT	DERIVED	SECONDARY	AXIAL	CT_SOM5 PAR	HPI	PAR
LungCARE send-to-Filming images	CT	DERIVED	SECONDARY	OTHER	CSA MIP THIN	LC VALID WINDOW	MIP
LungCARE send-to-Filming images	CT	DERIVED	SECONDARY	OTHER	CSA MPR THICK	LC VALID WINDOW	MPR
LungCARE send-to-Filming images	CT	DERIVED	SECONDARY	OTHER	CSA VRT THIN	LC VALID WINDOW	VRT

Somaris/5 Image Type (0008,0008) for objects created by Somaris/5

Image Type Description	IOD	0008,0008 Value 1	0008,0008 Value 2	0008,0008 Value 3	0008,0008 Value 4	0008,0008 Value 5	Somaris/5 Image Text
LungCARE send-to-Filming images	CT	DERIVED	SECONDARY	OTHER	CSA PRVT	LC VALID WINDOW	PVRT
LungCARE send-to-Filming images	CT	DERIVED	SECONDARY	OTHER	CSA MPR	LC VALID WINDOW	MPR
SC Derived Image (RGB) from VSim (see → page A.4–35)	SC	not set	not set	not set	not set	not set	not set

Specializations

Images created by Somaris/5

The following table lists the Somaris/5 image types and the corresponding combinations of the Image Type Attribute values:

Image Type Description [known creating applications]	IOD	0008,0008 Value 1	0008,0008 Value 2	0008,0008 Value 3	0008,0008 Value 4	0008,0008 Value 5	Somaris/5 Image Text or Lists
Averaged Image [Average, DynEva, Perfusion]	CT	DERIVED	SECONDARY	AXIAL	CT_SOM5 AVE	none	AVE
Interventional Cine Display Image	CT	ORIGINAL	PRIMARY	AXIAL	CT_SOM5 ICD	none	ICD
Monitoring Image	CT	ORIGINAL	PRIMARY	AXIAL	CT_SOM5 MON	none	MON
Premonitoring Image	CT	ORIGINAL	PRIMARY	AXIAL	CT_SOM5 MON	PMON	MON
Multiscan Image	CT	ORIGINAL	PRIMARY	AXIAL	CT_SOM5 MUL	none	MUL
Parameter Image (Arterial Liver Perfusion) [BodyPerfusion]	CT	DERIVED	SECONDARY	AXIAL	CT_SOM5 PAR	ALP	PAR
Parameter Image (Hepatic Perfusion Index) [BodyPerfusion]	CT	DERIVED	SECONDARY	AXIAL	CT_SOM5 PAR	HPI	PAR
Parameter Image (Portal Venous Liver Perfusion) [BodyPerfusion]	CT	DERIVED	SECONDARY	AXIAL	CT_SOM5 PAR	PVP	PAR

Image Type Description [known creating applications]	IOD	0008,0008 Value 1	0008,0008 Value 2	0008,0008 Value 3	0008,0008 Value 4	0008,0008 Value 5	Somaris/5 Image Text or Lists
Protocol Image, Time Density Curve Image [BodyPerfusion] ^a	SC	DERIVED	SECONDARY	OTHER	none	none	AC
Parameter Image (Patlak Blood Volume) [Perfusion]	CT	DERIVED	SECONDARY	AXIAL	CT_SOM5 PAR	PKBV	PAR
Parameter Image (Patlak Residual) [Perfusion]	CT	DERIVED	SECONDARY	AXIAL	CT_SOM5 PAR	PKER	PAR
Parameter Image (Patlak RSquare) [Perfusion]	CT	DERIVED	SECONDARY	AXIAL	CT_SOM5 PAR	PKR2	PAR
Parameter Image (Peak enhancement) [DynEva, Perfusion]	CT	DERIVED	SECONDARY	AXIAL	CT_SOM5 PAR	PKET	PAR
Parameter Image (Perfusion Blood Flow) [Perfusion]	CT	DERIVED	SECONDARY	AXIAL	CT_SOM5 PAR	PBF	PAR
Parameter Image (Perfusion Blood Volume) [Perfusion]	CT	DERIVED	SECONDARY	AXIAL	CT_SOM5 PAR	PBV	PAR
Parameter Image (Permeability) [Perfusion]	CT	DERIVED	SECONDARY	AXIAL	CT_SOM5 PAR	PMB	PAR

Image Type Description [known creating applications]	IOD	0008,0008 Value 1	0008,0008 Value 2	0008,0008 Value 3	0008,0008 Value 4	0008,0008 Value 5	Somaris/5 Image Text or Lists
Parameter Image (Time to Peak) [DynEva, Perfusion]	CT	DERIVED	SECONDARY	AXIAL	CT_SOM5 PAR	TTP	PAR
Parameter Image (Time to Start) [Perfusion]	CT	DERIVED	SECONDARY	AXIAL	CT_SOM5 PAR	TTS	PAR
Protocol Image	SC	DERIVED	SECONDARY	OTHER	CT_SOM5 PROT	none	PROT (List only)
Report Image (not finished)	SC	DERIVED	SECONDARY	OTHER	CT_SOM5 REP	IN_WORK	REP
Report Image (finished)	SC	DERIVED	SECONDARY	OTHER	CT_SOM5 REP	FINISHED	REP
ROT Image	CT	ORIGINAL	PRIMARY	AXIAL	CT_SOM5 ROT	none	ROT
Real Time Display Image	CT	ORIGINAL	PRIMARY	AXIAL	CT_SOM5 RTD	none	RTD
Real Time Display Image (Cardio)	CT	ORIGINAL	PRIMARY	AXIAL	CT_SOM5 RTD	STD	RTD
Multiscan Real Time Display Image	CT	ORIGINAL	PRIMARY	AXIAL	CT_SOM5 RTD	MRTD	RTD
Sequence Image	CT	ORIGINAL	PRIMARY / SECONDARY	AXIAL	CT_SOM5 SEQ	none	SEQ
Additional Scan Image	CT	ORIGINAL	PRIMARY / SECONDARY	AXIAL	CT_SOM5 SEQ	ADD	SEQ
Control Scan Image	CT	ORIGINAL	PRIMARY / SECONDARY	AXIAL	CT_SOM5 SEQ	CTL	SEQ

Image Type Description [known creating applications]	IOD	0008,0008 Value 1	0008,0008 Value 2	0008,0008 Value 3	0008,0008 Value 4	0008,0008 Value 5	Somaris/5 Image Text or Lists
Spiral Image	CT	ORIGINAL	PRIMARY / SECONDARY	AXIAL	CT_SOM5 SPI	none	SPI
Spiral Image (Cardio)	CT	ORIGINAL	PRIMARY / SECONDARY	AXIAL	CT_SOM5 SPI	STD	SPI
Spiral Oblique Image	CT	DERIVED	PRIMARY / SECONDARY	AXIAL	CT_SOM5 SPO	none	SPI
Static Image	CT	ORIGINAL	PRIMARY	OTHER	CT_SOM5 STA	none	STA
Subtracted Image	CT	DERIVED	SECONDARY	AXIAL	CT_SOM5 SUB	none	SUB
Topogram	CT	ORIGINAL	PRIMARY	LOCALIZER	CT_SOM5 TOP	none	TOP
Osteo Scanned Tomogram	CT	ORIGINAL	PRIMARY	AXIAL	CT_SOM5 SEQ	OTOM	SEQ
Osteo Scanned Topogram	CT	ORIGINAL	PRIMARY	LOCALIZER	CT_SOM5 TOP	OTOP	TOP
Osteo Evaluated Tomogram	CT	DERIVED	SECONDARY	AXIAL	CT_SOM5 OEVA	none	OEVA
Pulmo Evaluated Tomogram	CT	DERIVED	SECONDARY	AXIAL	CT_SOM5 PEVI	none	PEVI
Calcium Scoring Table [Calcium Scoring]	SC	DERIVED	SECONDARY	OTHER	CT_SOM5 TAB	none	TAB
Dental Filming Image	CT	DERIVED	SECONDARY	OTHER	CT_SOM5 DFLM	none	DFLM
Dental Panorama Rebuild Tomogram	CT	DERIVED	SECONDARY	OTHER	CT_SOM5 DPAN	none	DPAN

Image Type Description [known creating applications]	IOD	0008,0008 Value 1	0008,0008 Value 2	0008,0008 Value 3	0008,0008 Value 4	0008,0008 Value 5	Somar/5 Image Text or Lists
Dental Paraxial Rebuild Tomogram	CT	DERIVED	SECONDARY	OTHER	CT_SOM5 DPAR	none	DPAR
Dental/Volume Maximum Intensity Projection Image [Dental, Volume, DynEva, Perfusion]	CT	DERIVED	SECONDARY	AXIAL	CT_SOM5 MIP	none	MIP
Dental Panorama Reference Image [Dental, Volume]	CT	DERIVED	SECONDARY	AXIAL	CT_SOM5 MPR	none	MPR
Dental Paraxial Reference Image	CT	DERIVED	SECONDARY	AXIAL	CT_SOM5 MPR	none	MPR
Dental Reference Image	CT	DERIVED	SECONDARY	AXIAL	CT_SOM5 MPR	none	MPR
Dynamic Evaluation Averaged Baseline	CT	DERIVED	SECONDARY	AXIAL	CT_SOM5 DYB	none	DYB
Dynamic Evaluation Fused Multislice	CT	DERIVED	SECONDARY	AXIAL	CT_SOM5 DYF	none	DYF
Volume reformatted images (sagittal and coronal)	CT	DERIVED	SECONDARY	OTHER	CT_SOM5 MPR	none	MPR

Image Type Description [known creating applications]	IOD	0008,0008 Value 1	0008,0008 Value 2	0008,0008 Value 3	0008,0008 Value 4	0008,0008 Value 5	Somaris/5 Image Text or Lists
Various result images [CalciumScoring, Colon]	CT	DERIVED	SECONDARY	AXIAL	CSA MPR	none	MPR
Various result images	CT	DERIVED	SECONDARY	AXIAL	CSA MPR THICK	none	MPR
Various result images	CT	DERIVED	SECONDARY	AXIAL	CSA MIP	none	MIP
Various result images [CalciumScoring]	CT	DERIVED	SECONDARY	AXIAL	CSA MIP THIN	none	MIP
Various result images [Colon]	SC	DERIVED	SECONDARY	OTHER	CSA PSSD	none	PSSD
Various result images	CT	DERIVED	SECONDARY	AXIAL	CSA VRT	none	VRT
Various result images [Colon]	SC	DERIVED	SECONDARY	OTHER	CSA VRT	none	VRT
InSpace bookmark [InSpace]	SC	DERIVED	SECONDARY	OTHER	CSA BOOKMARK	RT3D CONFIG	BOOK
InSpace bookmark [InSpace]	SC	DERIVED	SECONDARY	OTHER	CSA 3DPROJECTION	none	3DPR
LungCARE save images [LungCARE]	SC	DERIVED	SECONDARY	OTHER	MIP	LC VALID WINDOW	MIP
LungCARE save images [LungCARE]	SC	DERIVED	SECONDARY	OTHER	MRP	LC VALID WINDOW	MRP



Image Type Description [known creating applications]	IOD	0008,0008 Value 1	0008,0008 Value 2	0008,0008 Value 3	0008,0008 Value 4	0008,0008 Value 5	Somaris/5 Image Text or Lists
LungCARE save images [LungCARE]	SC	DERIVED	SECONDARY	OTHER	VRT	LC VALID WINDOW	VRT
LungCARE save images [LungCARE]	SC	DERIVED	SECONDARY	OTHER	PVRT	LC VALID WINDOW	PVRT
LungCARE save images [LungCARE]	CT	DERIVED	SECONDARY	OTHER	MPR	LC VALID WINDOW	MPR
LungCARE save images [LungCARE]	CT	DERIVED	SECONDARY	OTHER	CT_SOM5 SPI	LC VALID WINDOW	SPI
LungCARE save report images [LungCARE]	SC	DERIVED	SECONDARY	OTHER	MIP	LC VALID WINDOW	none
LungCARE save report images [LungCARE]	SC	DERIVED	SECONDARY	OTHER	MRP	LC VALID WINDOW	none
LungCARE save report images [LungCARE]	SC	DERIVED	SECONDARY	OTHER	VRT	LC VALID WINDOW	none
LungCARE save report images [LungCARE]	SC	DERIVED	SECONDARY	OTHER	PVRT	LC VALID WINDOW	none
Various Graphics [DynEva, Osteo, Pulmo, Volume, Perfusion, Argus, VesselView]	SC	DERIVED	SECONDARY	OTHER	CSA BLACK IMAGE	none	none

Image Type Description [known creating applications]	IOD	0008,0008 Value 1	0008,0008 Value 2	0008,0008 Value 3	0008,0008 Value 4	0008,0008 Value 5	Somaris/5 Image Text or Lists
SC Derived Image (Monochrome) from VSim (see → page A.4–35)	SC	DERIVED	SECONDARY	from Original	CSAMPR or CSAMIP or CSADRR	none	none

a. More detailed attribute information will be provided in a future version.

Note

Some applications will create Structured Reports. However, when running in specific (service configured) settings outside of the system they will appear as a SC image, labelled as Type 3 "OTHER" and Type 4 "CSA REPORT". This private extension is not published in detail here because the intended use is real DICOM SR.

For Protocol Image, Some additional information about DOSE INFO is added into Application Header Sequence(0029,xx40), detailed info about this Sequence see "Somaris/5 Attribute Interpretation" in → page A.4–30.

Structured Reports created by Somaris/5

The following table lists the Somaris/5 image types and the corresponding combinations of the Image Type Attribute value.

Image Type Description [known creating applications]	IOD	0008,0008 Value 1	0008,0008 Value 2	0008,0008 Value 3	0008,0008 Value 4	0008,0008 Value 5	Somaris/5 Image Text
LungCARE SR reports [LungCARE, Calcium Scoring, Circulation]	SR	ORIGINAL	PRIMARY	OTHERS	CSA REPORT	none	none
CT Dose SR	SR	ORIGINAL	PRIMARY	OTHER	CSA REPORT	none	none

LungCARE, Calcium Scoring and Circulation create Comprehensive Structured Reports.

The following is valid for Calcium Scoring created Structured Reports:

CaScoring creates structured reports generally following the templates defined in DICOM supplement 97 "CT/MR Cardiovascular Analysis Report" (Version: 0.11; Working Draft). Some changes of these templates that could not be considered may occur until document is released as final version.

The following is valid for Circulation created Structured Reports:

Circulation creates structured reports generally following the DICOM template TID3900.

Somaris system create CT Dose Structured Reports as a default configuration for every patient when he/she finish measurement.(user can disable this function.)



CT Dose Report generally follows the templates defined in DICOM Standard 2008 “CT Radiation Dose”.

The following is valid for CT Dose Structured Reports:

CT Dose SR follows the DICOM template TID10011.

Somaris/5 Attribute Interpretation

For an overview of selected attribute filling for different Image Types please refer to the Annex.

The table below explains how common attributes of created and uncompressed ORIGINAL and AXIAL images are set by Somaris/5 image reconstruction. This table does not intend to be a substitute for DICOM 3.0 attribute definitions. However, in addition to these it will provide an impression of which attributes are in common use - and how they are related to Somaris/5 examination:

Tag	Name	Explanation
0002,0012	Implementation Class UID	Value: 1.3.12.2.1107.5.1.4
0002,0013	Implementation Version Name	Value: "SIEMENS_S5VB38A"
0008,0005	Specific Character Set	
0008,0008	Image Type	see → page A.4–13
0008,0016	SOP Class UID	Value: 1.2.840.10008.5.1.4.1.1.2
0008,0018	SOP Instance UID	created
0008,0020	Study Date	For existing studies their date and time entries are copied into the corresponding entries in a new image's header. If a new study is created the date and time entries from the first series of this new study will be used.
0008,0030	Study Time	
0008,0021	Series Date	For existing series their date and time entries are copied into the corresponding entries in a new image's header. If a new series is created the current real-world date and time will be used.
0008,0031	Series Time	

Tag	Name	Explanation
0008,0022	Acquisition Date	Acquisition Date and Time is defined as the real-world beginning of the accumulation of data which contribute to a particular image. Due to the multi-slice technology several images may have the same Acquisition Date and Time.
0008,0032	Acquisition Time	
0008,0023	Image (Content) Date	For all images which result from a reconstruction of acquired data, the time stamp is the same as Acquisition Date and Time. This is true for images that were reconstructed immediately after data acquisition as well as for images that were reconstructed at any time later. For all other images created by any other means the time stamp is derived from a point in time during the creation process of these images.
0008,0033	Image (Content) Time	
0008,0050	Accession Number	Input entered from MWL or during patient registration. May be null-length. NOTE: When Study Split is used, the value corresponding to the Requested Procedure Description selected in Exam UI will be sent
0008,0060	Modality	Value: CT
0008,0070	Manufacturer	Value: SIEMENS
0008,0080	Institution Name	Hospital name read from configuration data or user input entered during patient registration or examination setup
0008,0081	Institution Address	Hospital address read from configuration data. Default format is 4 lines containing Street, City, District and Country.
0008,0090	Referring Physician's Name	Input from MWL or entered during patient registration or examination setup. May be null-length.
0008,1010	Station Name	Name of the computer the examination is controlled with

Tag	Name	Explanation
0008,1030	Study Description	Is derived from information entered during patient registration or examination setup. Concatenated from Body Region and selected Scan Protocol name, separated by a "^" NOTE: When Study Split is used, the Requested Procedure Description selected in Exam UI will be sent
0008,1050	Performing Physician's Name	Input entered from MWL or during patient registration.
0008,1070	Operator's Name	According to user input
0008,1080	Admitting Diagnoses Description	Input entered from MWL or during patient registration.
0008,103E	Series Description	According to user input (system proposes <Range Name> <Slice Thickness> <Kernel>)
0008,1090	Manufacturer's Model Name	The Siemens product name
0008,1140	Referenced Image Sequence	
>0008,1150	Referenced SOP Class UID	SOP Class UID of Topogram used for planning
>0008,1155	Referenced SOP Instance UID	SOP Instance UID of Topogram used for planning
0008,2112	Source Image Sequence	
>0008,1150	Referenced SOP Class UID	SOP Class UID of Rawdata used for reconstruction
>0008,1155	Referenced SOP Instance UID	SOP Instance UID of Rawdata used for reconstruction
0008,2111	Derivation Description	Lossy Image Compression will be set to 01 for Extended Field of View because of low image quality. Derivation Description: "Reconstruction field larger than scan field"

Tag	Name	Explanation
0009,00xx	Private Creator	Value: SIEMENS CT VA1 DUMMY
0010,0010	Patient's Name	Input from MWL or entered during patient registration or examination setup.
0010,0020	Patient ID	Input from MWL or entered or generated during patient registration or examination setup.
0010,0030	Patient's Birth Date	Input from MWL or entered during patient registration or examination setup. May be calculated from age.
0010,0040	Patient's Sex	Input from MWL or entered during patient registration or examination setup.
0010,1010	Patient's Age	Input from MWL or entered during patient registration or examination setup. May be calculated from Patient's Birth Date
0018,0010	Contrast/Bolus Agent	If present: The attribute is filled with the value entered in the contrast card. If nothing was entered the attribute is filled with the fixed term "APPLIED".



Tag	Name	Explanation																								
0018,0015	Body Part Examined	<p>The Body Part Examined is derived from the organ characteristic of the scan or directly entered by the operator, which overrides this default.</p> <p>The organ characteristic parameter is contained in the scan protocol selected for examination during patient registration or examination setup and may vary for different scans within one protocol (use System/Run/List Scan Protocols column "OrgChar" for a list of values for specific scan protocols).</p> <table border="1"> <thead> <tr> <th>Organ Characteristic</th> <th>Body Part Examined</th> </tr> </thead> <tbody> <tr><td>Head</td><td>HEAD</td></tr> <tr><td>Neck</td><td>NECK</td></tr> <tr><td>Shoulder</td><td>SHOULDER</td></tr> <tr><td>Thorax</td><td>CHEST</td></tr> <tr><td>Abdomen</td><td>ABDOMEN</td></tr> <tr><td>Spine</td><td>SPINE</td></tr> <tr><td>Pelvis</td><td>PELVIS</td></tr> <tr><td>Extremities</td><td>EXTREMITY</td></tr> <tr><td>Cardio</td><td>HEART</td></tr> <tr><td>Service</td><td>SERVICE</td></tr> <tr><td>n. a.</td><td>UNKNOWN</td></tr> </tbody> </table>	Organ Characteristic	Body Part Examined	Head	HEAD	Neck	NECK	Shoulder	SHOULDER	Thorax	CHEST	Abdomen	ABDOMEN	Spine	SPINE	Pelvis	PELVIS	Extremities	EXTREMITY	Cardio	HEART	Service	SERVICE	n. a.	UNKNOWN
Organ Characteristic	Body Part Examined																									
Head	HEAD																									
Neck	NECK																									
Shoulder	SHOULDER																									
Thorax	CHEST																									
Abdomen	ABDOMEN																									
Spine	SPINE																									
Pelvis	PELVIS																									
Extremities	EXTREMITY																									
Cardio	HEART																									
Service	SERVICE																									
n. a.	UNKNOWN																									
0018,0050	Slice Thickness	Resulting slice thickness. Not necessarily equal to collimated slice.																								
0018,0060	KVP	Voltage selected for scan.																								
0018,0090	Data Collection Diameter																									
0018,1000	Device Serial Number	Serial number of the CT system's gantry.																								
0018,1020	Software Version(s)	Software Version of Somaris/5. Only one value is used.																								
0018,1030	Protocol Name	Name of Scan Protocol selected during patient registration or examination setup																								
0018,1100	Reconstruction Diameter	Field of View selected for reconstruction																								

Tag	Name	Explanation
0018,1110	Distance Source to Detector	
0018,1111	Distance Source to Patient	
0018,1120	Gantry/Detector Tilt	
0018,1130	Table Height	Table height as entered for scan
0018,1140	Rotation Direction	
0018,1150	Exposure Time	The exposure time for the respective image. For spiral scan or multiscan this corresponds to the rotation time.
0018,1151	X-ray Tube Current	Tube current used for scanning
0018,1152	Exposure	(Effective) mAs. For spiral images the product of exposure time and x-ray tube current is corrected with Table Feed per Rotation. Expressed in mAs.
0018,1160	Filter Type	0: No Filter, 1: Teflon Filter
0018,1170	Generator Power	
0018,1190	Focal Spots	Size of the focal spot actually used to generate x-ray radiation for a particular image. This is a single value expressed in mm.
0018,1200	Date of Last Calibration	Date of last Base Calibration
0018,1201	Time of Last Calibration	Time of last Base Calibration
0018,1210	Convolution Kernel	4 character code of convolution kernel
0018,5100	Patient Position	As entered for scan

Tag	Name	Explanation																														
0018,9323	Exposure Modulation Type	A label describing the type of exposure modulation used for the purpose of limiting the dose. Defined Terms: <table border="0"> <tr> <td>ModeLib DoseModulationType</td> <td>DICOM Entry (string)</td> </tr> <tr> <td>MIZAxisExposureControl</td> <td>Z_EC</td> </tr> <tr> <td>MIOnlineControl</td> <td>XY_EC</td> </tr> <tr> <td>MIImAControl</td> <td>FIX_EC</td> </tr> <tr> <td>MIAutomaticExposureControl</td> <td>XYZ_EC</td> </tr> <tr> <td>MIDvModulation</td> <td>PULS_EC</td> </tr> <tr> <td>MIDvAdvanced</td> <td>PULS_MINDOSE_EC</td> </tr> <tr> <td>MIDvModulationZEC</td> <td>PULS_EC</td> </tr> <tr> <td>MIDvAdvancedZEC</td> <td>PULS_MINDOSE_EC</td> </tr> <tr> <td>MIDvModulationMAC</td> <td>PULS_EC</td> </tr> <tr> <td>MIDvAdvancedMAC</td> <td>PULS_MINDOSE_EC</td> </tr> <tr> <td>MIAngularTrigger</td> <td>XY_PREDEF_EC</td> </tr> <tr> <td>MIAngularTriggerZEC</td> <td>XY_PREDEF_Z_EC</td> </tr> <tr> <td>MIAngularTriggerMAC</td> <td>XY_PREDEF_FIX_EC</td> </tr> <tr> <td>MINoModulation</td> <td>OFF</td> </tr> </table>	ModeLib DoseModulationType	DICOM Entry (string)	MIZAxisExposureControl	Z_EC	MIOnlineControl	XY_EC	MIImAControl	FIX_EC	MIAutomaticExposureControl	XYZ_EC	MIDvModulation	PULS_EC	MIDvAdvanced	PULS_MINDOSE_EC	MIDvModulationZEC	PULS_EC	MIDvAdvancedZEC	PULS_MINDOSE_EC	MIDvModulationMAC	PULS_EC	MIDvAdvancedMAC	PULS_MINDOSE_EC	MIAngularTrigger	XY_PREDEF_EC	MIAngularTriggerZEC	XY_PREDEF_Z_EC	MIAngularTriggerMAC	XY_PREDEF_FIX_EC	MINoModulation	OFF
ModeLib DoseModulationType	DICOM Entry (string)																															
MIZAxisExposureControl	Z_EC																															
MIOnlineControl	XY_EC																															
MIImAControl	FIX_EC																															
MIAutomaticExposureControl	XYZ_EC																															
MIDvModulation	PULS_EC																															
MIDvAdvanced	PULS_MINDOSE_EC																															
MIDvModulationZEC	PULS_EC																															
MIDvAdvancedZEC	PULS_MINDOSE_EC																															
MIDvModulationMAC	PULS_EC																															
MIDvAdvancedMAC	PULS_MINDOSE_EC																															
MIAngularTrigger	XY_PREDEF_EC																															
MIAngularTriggerZEC	XY_PREDEF_Z_EC																															
MIAngularTriggerMAC	XY_PREDEF_FIX_EC																															
MINoModulation	OFF																															
0019,00xx	Private Creator	Value: SIEMENS CT VAO COAD																														
0019,xxB0	Feed per Rotation	Movement of table during one rotation in mm																														
0020,000D	Study Instance UID	From MWL or created NOTE: When Study Split is used, the value corresponding to the Requested Procedure Description selected in Exam UI will be sent																														
0020,000E	Series Instance UID	From MWL or created																														
0020,0010	Study ID	From MWL or created NOTE: When Study Split is used, the value corresponding to the Requested Procedure Description selected in Exam UI will be sent																														
0020,0011	Series Number	created																														

Tag	Name	Explanation
0020,0012	Acquisition Number	Scan number within this examination.
0020,0013	Instance Number	created; direction within range selectable by user
0020,0032	Image Position (Patient)	The x, y, and z coordinates of the center of the first pixel, in mm.
0020,0037	Image Orientation (Patient)	
0020,0052	Frame of Reference UID	created
0020,1040	Position Reference Indicator	null-length
0020,1041	Slice Location	Topogram: Slice Location is defined as the relative table position of the very beginning of the Topogram image expressed in mm. Tomogram: Slice Location is defined as the relative position of the intersection of the image's slice with the z-axis expressed in mm. This positions is relative to the current reference point and corresponds to the table position.
0020,4000	Image Comments	According to user input. 2 lines supported.
0021,00xx	Private Creator	Value: SIEMENS MED
0021,xx11	Target	Center x/y as entered for reconstruction
0028,0002	Samples per Pixel	Value: 1
0028,0004	Photometric Interpretation	Value: MONOCHROME2
0028,0010	Rows	
0028,0011	Columns	
0028,0030	Pixel Spacing	
0028,0100	Bits Allocated	Value: 16
0028,0101	Bits Stored	Value: 12

Tag	Name	Explanation
0028,0102	High Bit	Value: 11
0028,0103	Pixel Representation	Value: 0
0028,0106	Smallest Image Pixel Value	Calculated by examination
0028,0107	Largest Image Pixel Value	Calculated by examination
0028,1050	Window Center	Last windowing center saved. First window followed by second window.
0028,1051	Window Width	Last windowing width saved. First window followed by second window.
0028,1052	Rescale Intercept	Value -1024 for images without extended CT scale
0028,1053	Rescale Slope	Value 1 for images without extended CT scale
0028,1055	Window Center & Width Explanation	Value: "WINDOW1", "WINDOW2"
0028,2110	Lossy Image Compression	Lossy Image Compression will be set to 01 for Extended Field of View because of low image quality. Derivation Description: "Reconstruction field larger than scan field"
0029,xxxx	(private data)	see → page A.4–77
0029,xx40	Application Header Sequence	see → page A.4–77
>0029,00xx	Private Creator	"SIEMENS MEDCOM HEADER"
>0029,xx41	Application Header Type	"SOM 5 TPOS" "SOMARIS DOSEINFO"
>0029,xx42	Application Header ID	"SOM 5 NULLPOSITION" "SOMARIS DOSEINFO DATA"
>0029,xx43	Application Header Version	"VB10A 20030626" "20080109"

Tag	Name	Explanation
>0029,xx44	Application Header Info	Table Null Position coded as a null terminated character buffer Character string dose information from patient protocol
0032,1060	Requested Procedure Description	Input entered during patient registration or examination setup. NOTE: When Study Split is used, the value corresponding to the Requested Procedure Description selected in Exam UI will be sent
7FE0,0010	Pixel Data	

OOG, Overlays, High Bits

Graphics in Somaris/5 images are stored as Object Oriented Graphics (OOG) in private attributes (→ page A.4–87, *MEDCOM OOG Module*). Non *syngo* based systems are not expected to interpret this information.

In order to allow display access to graphics information for DICOM based systems private OOG information is converted on export into DICOM Overlay information stored in group 6000. This is the recommended way for a DICOM based system to access overlay graphics information.

The following attributes are generated:

Overlay Rows (6000,0010)

Overlay Columns (6000,0011)

Number of Frames in Overlay (6000,0015)

Overlay Description (6000,0022) =
"Siemens MedCom Object Graphics"

Overlay Type (6000,0040) = "G"

Origin (6000,0050) = 1, 1

Image Frame Origin (6000,0051)

Overlay Bits Allocated (6000,0100)

Bit Position (6000,0102)

Overlay Data (6000,3000)

However, DICOM Overlay information stored in group 6000 is not supported by all systems that might be used to store Somaris/5 images. These systems may not be able to display Somaris/5 generated overlays. For a special group of these systems there is another way to provide graphical overlay information. A remote node can be configured to have overlay graphics converted into unused pixel data above High Bit (0028,0102) for images that fulfil the following condition:

- ❑ bits allocated (attribute 0028, 0100) = 16
- ❑ bits stored (attribute 0028,0101) = 12
- ❑ high bit (attribute 0028,0102) = 11

Some systems are known to support this coding; they are able to display this information with the images. Please note, however, that the proper and recommended way to store overlays with DICOM is the use of group 6000.

SC derived images from VSim

SC Derived Image(RGB) from VSim.

An overview of supplied attributes - SC derived image (RGB) from VSim:

Attribute Name	Tag	Value
Specific Character Set	(0008,0005)	(conf. Character Set is added, if needed)
Image Type	(0008,0008)	Not Set.
SOP Class UID	(0008,0016)	1.2.840.10008.5.1.4.1.1.7
SOP Instance UID	(0008,0018)	Generated based on image creation date and time
Study Date	(0008,0020)	from original
Series Date	(0008,0021)	If 'new series': <yyyymmdd>
Acquisition Date	(0008,0022)	from original
Image Date	(0008,0023)	Not Set.
Study Time	(0008,0030)	from original
Series Time	(0008,0031)	If 'new series': <hhmmss>
Acquisition Time	(0008,0032)	from original
Image Time	(0008,0033)	Not Set.
Accession Number	(0008,0050)	from original
Modality	(0008,0060)	OT
Conversion Type	(0008,0064)	WSD
Manufacturer	(0008,0070)	Siemens Oncology Care Solutions
Institution Name	(0008,0080)	Not Set.
Institution Address	(0008,0081)	Not Set.
Referring Physician´s Name	(0008,0090)	from original

Attribute Name	Tag	Value
Station Name	(0008,1010)	Not Set.
Study Description	(0008,1030)	Vsim_TmpSeries_<num> num= a running number
Series Description	(0008,103E)	Not Set.
Institutional Department Name	(0008,1040)	Not Set.
Performing Physician´s Name	(0008,1050)	Not Set.
Admitting Diagnosis Description	(0008,1080)	Not Set.
Manufacturer´s Model Name	(0008,1090)	VSim
Derivation Description	(0008,2111)	<algorithm> (see [0008,0008])
Patient´s Name	(0010,0010)	from Original
Patient ID	(0010,0020)	from Original
Patient´s Birth Date	(0010,0030)	from Original
Patient´s Sex	(0010,0040)	from Original
Device Serial Number	(0018,1000)	Not Set.
Secondary Capture Device ID	(0018,1010)	Not Set.
Date of Secondary Capture	(0018,1012)	<yyyymmdd>
Time of Secondary Capture	(0018,1014)	<hhmmss>
Secondary Capture Device Manufacturer	(0018,1016)	Not Set.
Secondary Capture Device Manufacturer´s Model Name	(0018,1018)	Not Set.
Secondary Capture Device Software Version	(0018,1019)	Not Set.
Software Version	(0018,1020)	String containing the build version of VSim.

Attribute Name	Tag	Value
Protocol Name	(0018,1030)	From original
Study Instance UID	(0020,000D)	from original
Series Instance UID	(0020,000E)	If new series generated based on date and time of image creation else the original
Study ID	(0020,0010)	from original
Series Number	(0020,0011)	<num> num=a running number
Image Number	(0020,0013)	<num> num=a running number
Patient Orientation	(0020,0020)	zero length
Laterality	(0020,0060)	Not Set.
Image Comments	(0020,4000)	Not Set.
Samples per Pixel	(0028,0002)	3
Photometric Interpretation	(0028,0004)	RGB
Rows	(0028,0010)	from original for MPR and MIP images 512 for DRR images
Columns	(0028,0011)	from original for MPR and MIP images 512 for DRR images
Bits Allocated	(0028,0100)	8
Bits Stored	(0028,0101)	8
High Bit	(0028,0102)	7
Pixel Representation	(0028,0103)	0
Window Center	(0028,1050)	Not Set.
Window Width	(0028,1051)	Not Set.
Window Center & Width Explanation	(0028,1055)	Not Set.
Study Comments	(0032,4000)	from original

Attribute Name	Tag	Value
Overlay Rows	(60xx,0010)	Not Set.
Overlay Columns	(60xx,0011)	Not Set.
Overlay Description	(60xx,0022)	Not Set.
Overlay Type	(60xx,0040)	Not Set.
Overlay Origin	(60xx,0050)	Not Set.
Overlay Bits Allocated	(60xx,0100)	Not Set.
Overlay Bit Position	(60xx,0102)	Not Set.
Overlay Data	[60xx,3000]	Not Set.
Pixel Data	(7FE0,0010)	Not Set.

SC Derived Image (Monochrome) from VSim.

An overview of supplied attributes - SC derived image (monochrome) from VSim:

Attribute Name	Tag	Value
Specific Character Set	(0008,0005)	(conf. Character Set is added, if needed)
Specific Character Set	(0008,0005)	(conf. Character Set is added, if needed)
Image Type	(0008,0008)	DERIVED\SECONDARY\from Original <Value4> Value4=CSAMPR or CSAMIP or CSADRR
SOP Class UID	(0008,0016)	1.2.840.10008.5.1.4.1.1.7
SOP Instance UID	(0008,0018)	Generated based on image creation date and time
Study Date	(0008,0020)	from original
Series Date	(0008,0021)	If 'new series': <yyyymmdd>
Acquisition Date	(0008,0022)	from original
Image Date	(0008,0023)	Not Set.

Attribute Name	Tag	Value
Study Time	(0008,0030)	from original
Series Time	(0008,0031)	If 'new series': <hhmmss>
Acquisition Time	(0008,0032)	from original
Image Time	(0008,0033)	Not Set.
Accession Number	(0008,0050)	from original
Modality	(0008,0060)	OT
Conversion Type	(0008,0064)	WSD
Manufacturer	(0008,0070)	Siemens Oncology Care Solutions
Institution Name	(0008,0080)	Not Set.
Institution Address	(0008,0081)	Not Set.
Referring Physician's Name	(0008,0090)	from original
Station Name	(0008,1010)	Not Set.
Study Description	(0008,1030)	VSim_TmpSeries_<num> num = a running number
Series Description	(0008,103E)	Not Set.
Institutional Department Name	(0008,1040)	Not Set.
Performing Physician's Name	(0008,1050)	Not Set.
Admitting Diagnosis Description	(0008,1080)	Not Set.
Manufacturer's Model Name	(0008,1090)	VSim
Derivation Description	(0008,2111)	<algorithm> (see [0008,0008])
Patient's Name	(0010,0010)	from Original
Patient ID	(0010,0020)	from Original
Patient's Birth Date	(0010,0030)	from Original
Patient's Sex	(0010,0040)	from Original

Attribute Name	Tag	Value
Device Serial Number	(0018,1000)	Not Set.
Secondary Capture Device ID	(0018,1010)	Not Set.
Date of Secondary Capture	(0018,1012)	<yyyymmdd>
Time of Secondary Capture	(0018,1014)	<hhmmss>
Secondary Capture Device Manufacturer	(0018,1016)	Not Set.
Secondary Capture Device Manufacturer's Model Name	(0018,1018)	Not Set.
Secondary Capture Device Software Version	(0018,1019)	Not Set.
Software Version	(0018,1020)	String containing the build version of VSim.
Protocol Name	(0018,1030)	From original
Study Instance UID	(0020,000D)	from original
Series Instance UID	(0020,000E)	If new series generated based on date and time of image creation else the original
Study ID	(0020,0010)	from original
Series Number	(0020,0011)	<num> num=a running number
Image Number	(0020,0013)	<num> num=a running number
Patient Orientation	(0020,0020)	zero length
Laterality	(0020,0060)	Not Set.
Image Comments	(0020,4000)	Not Set.
Samples per Pixel	(0028,0002)	1
Photometric Interpretation	(0028,0004)	MONOCHROME2
Rows	(0028,0010)	from original for MPR and MIP images 512 for DRR images
Columns	(0028,0011)	from original for MPR and MIP images 512 for DRR images

Attribute Name	Tag	Value
Bits Allocated	(0028,0100)	from original for MPR and MIP images
Bits Stored	(0028,0101)	from original for MPR and MIP images
High Bit	(0028,0102)	from original for MPR and MIP images
Pixel Representation	(0028,0103)	0
Window Center	(0028,1050)	Not Set.
Window Width	(0028,1051)	Not Set.
Window Center & Width Explanation	(0028,1055)	Not Set.
Study Comments	(0032,4000)	from original
Overlay Rows	(60xx,0010)	from original
Overlay Columns	(60xx,0011)	from original
Overlay Description	(60xx,0022)	from original
Overlay Type	(60xx,0040)	from original
Overlay Origin	(60xx,0050)	from original
Overlay Bits Allocated	(60xx,0100)	from original
Overlay Bit Position	(60xx,0102)	from original
Overlay Data	[60xx,3000]	Graphics Overlay
Pixel Data	(7FE0,0010)	from original

IOD Specific Implementation Details for VSim

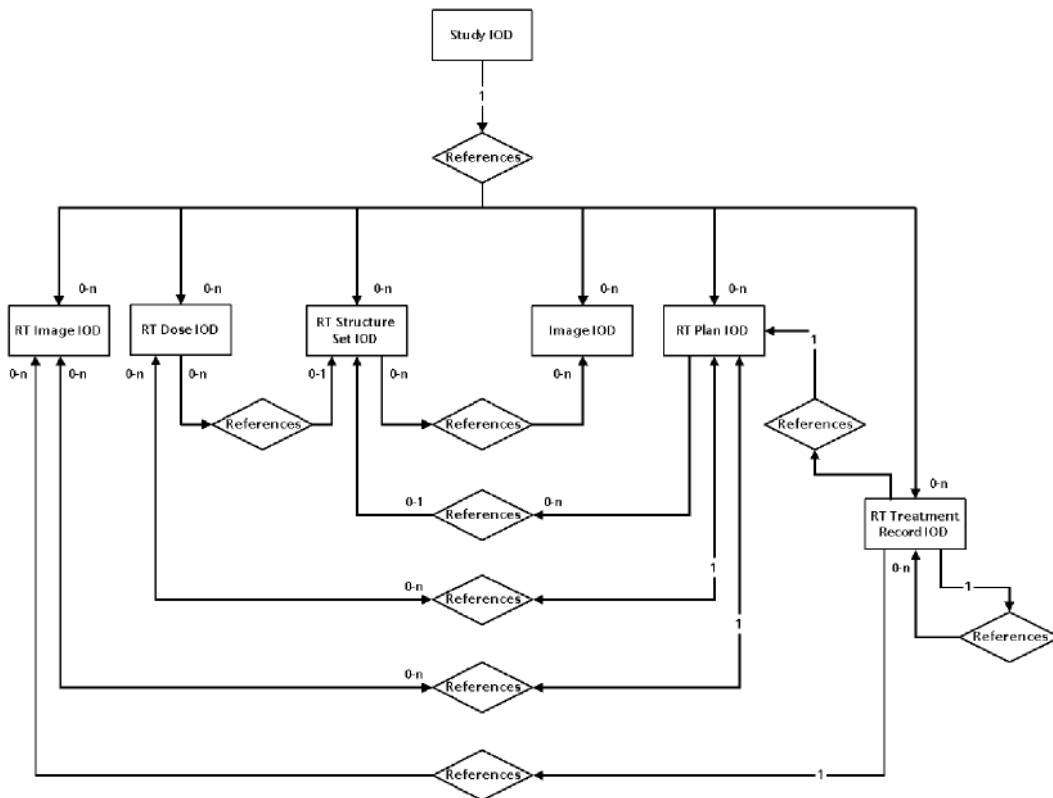

The VSim application RT IOD specific implementation details are provided with respect to its role as service class user (SCU) as well as service class provider (SCP) in the notes.

The VSim application as service class provider (SCP) makes a copy of all non siemens RT objects identified by General Equipment Module Manufacturer Name (0008,0070) set other than "Siemens Oncology Care Solutions" and Manufacturer's Model Name (0008,1090) set other than "COHERENCE Dosimetrist Workspace". During import of non siemens RT objects in the case that the provided value of an attribute is other than that expected by the VSim application; the attribute is corrected in copied RT object as in the notes below. The original RT objects are kept intact.

RT Structure Set IOD Module for VSim

IE	Module	Reference	Usage	Notes
Patient	Patient	C 7.1.1	M	
Study	General Study	C 7.2.1	M	
	Patient Study	C 7.2.2	U	Not Supported
Series	RT Series	C 8.8.1	M	
Equipment	General Equipment	C 7.5.1	M	
StructureSet	Structure Set	C 8.8.5	M	
	ROI Contour	C 8.8.6	M	
	RT ROI Observation	C 8.8.8	M	
	Approval	C 8.8.16	U	Not Supported
	Audio	C 10.3	U	Not Supported
	SOP Common	C 12.1	M	



RT Structure Set IOD Module for VSim				
IE	Module	Reference	Usage	Notes
Patient	Patient	C 7.1.1	M	
Study	General Study	C 7.2.1	M	
	Patient Study	C 7.2.2	U	Not Supported
Series	RT Series	C 8.8.1	M	
Equipment	General Equipment	C 7.5.1	M	
StructureSet	Structure Set	C 8.8.5	M	
	ROI Contour	C 8.8.6	M	
	RT ROI Observation	C 8.8.8	M	
	Approval	C 8.8.16	U	Not Supported
	Audio	C 10.3	U	Not Supported
	SOP Common	C 12.1	M	

RT Plan IOD Module Table for VSim				
IE	Module	Reference	Usage	Notes
Patient	Patient	C 7.1.1	M	
Study	General Study	C 7.2.1	M	
	Patient Study	C 7.2.2	U	Not Supported
Series	RT Series	C 8.8.1	M	
Equipment	General Equipment	C 7.5.1	M	

RT Plan IOD Module Table for VSim				
IE	Module	Reference	Usage	Notes
Plan	RT General Plan	C 8.8.9	M	
	RT Prescription	C 8.8.10	U	Not Supported
	RT Tolerance Tables	C 8.8.11	U	Not Supported
	RT Patient Setup	C 8.8.12	U	
	RT Fraction Scheme	C 8.8.13	U	Not Supported
	RT Beams	C 8.8.14	C	
	RT Brachy Application Setups	C 8.8.15	C	Not Supported
	Approval	C 8.8.16	U	Not Supported
	Audio	C 10.3	U	Not Supported
	SOP Common	C 12.1	M	



RT Image IOD Module Table for VSim				
IE	Module	Reference	Usage	Notes
Patient	Patient	C 7.1.1	M	
Study	General Study	C 7.2.1	M	
	Patient Study	C 7.2.2	U	Not Supported
Series	RT Series	C 8.8.1	M	
Frame of Reference	Frame of Reference	C 7.4.1	U	
Equipment	General Equipment	C 7.5.1	M	



RT Image IOD Module Table for VSim				
IE	Module	Reference	Usage	Notes
Image	General Image	C 7.6.1	M	
	Image Pixel	C 7.6.3	M	
	Contrast/bolus	C 7.6.4	C	Not Supported
	Cine	C 7.6.5	C	Not Supported
	Multi-Frame	C 7.6.6	C	Not Supported
	RT Image	C 8.8.2	M	
	Modality LUT	C 11.1	U	Not Supported
	VOI LUT	C 11.2	U	Not Supported
	Approval	C 8.8.16	U	Not Supported
	Curve	C 10.2	U	Not Supported
	Audio	C 10.3	U	Not Supported
	SOP Common	C 12.1	M	

Note

Whenever an existing RT object is changed and saved, VSim generates new SOP Instance UIDs for the RT IODs saved.

RT Series Module Table for VSim

Attribute Name	Tag	Comments
Modality	(0080,0060)	RTIMAGE = RT Image RTSTRUCT = RT StructureSet RTPLAN = RT Plan RTDOSE and RTRECORD are not supported.
Series Instance UID	(0020,000E)	Filled at the time of Series creation
Series Number	(0020,0011)	Filled at the time of creation.
Series Description	(0008,103E)	Filled at the time of creation.
Referenced Study Component Sequence	(0008,1111)	Not Set.
Request Attributes Sequence	(0040,0275)	Not Set.
Performed Procedure Step ID	(0040,0253)	Not Set.
Performed Procedure Step Start Date	(0040,0244)	Not Set.
Performed Procedure Step Start Time	(0040,0245)	Not Set.
Performed Procedure Step Description	(0040,0254)	Not Set.
Performed Protocol Sequence	(0040,0260)	Not Set.

General Equipment Module Table for VSim

Attribute Name	Tag	Comments
Manufacturer	(0008,0070)	VSim fills this attribute with a string which is containing the manufacturer name which is always "Siemens Oncology Care Solutions". In case provided value is other than "Siemens Oncology Care Solutions" during import the attribute is filled with same value as VSim created RT objects.

General Equipment Module Table for VSim

Attribute Name	Tag	Comments
Institution Name	(0008,0080)	Not Set.
Institution Address	(0008,0081)	Not Set.
Station Name	(0008,1010)	Not Set.
Institutional Department Name	(0008,1040)	Not Set.
Manufacturer's Model Name	(0008,1090)	<p>VSim fills this attribute with a string containing the workspace name used to create the objects. For VSim this value is always "COHERENCE Dosimetrist Workspace".</p> <p>In case provided value is other than "VSim" during import the attribute is filled with same value as VSim created RT objects.</p>
Device Serial Number	(0018,1000)	Not Set.
Software Versions	(0018,1020)	<p>String containing the build and version information of VSim software used to create RT Objects.</p> <p>Format: 2.0.100 - Implies version 2.0, build 100 of VSim software was used to create the objects.</p>
Spatial Resolution	(0018,1050)	Not Set.
Date of Last Calibration	(0018,1200)	Not Set.
Time of Last Calibration	(0018,1201)	Not Set.
Pixel Padding Value	(0028,0120)	Not Set.



RT Structure Set Module Table for VSim		
Attribute Name	Tag	Notes
Structure Set Label	(3006,0002)	VSim always fills this attribute with the string "VSimStructureSet" In case of non siemens RT objects the attribute is filled with same value as VSim created RT objects.
Structure Set Name	(3006,0004)	String containing the build and version information of VSim software used to create the structure set. Format: VSim x.y SL nnn Where x.y is the VSim version nnn- Build number In case of non siemens RT objects the attribute is filled with same value as VSim created RT object
Instance Number	(0020,0013)	An integer value In case of non siemens RT objects the attribute is filled with internally generated integer value for copied structure set.
Structure Set Date	(3006,0008)	Last modification date In case not provided set to system date.
Structure Set Time	(3006,0009)	Last modification time. In case not provided set to system time. Referenced Frame of Reference
Sequence	(3006,0010)	Dataset must have sequence describing the frame of reference for the dataset. Only one sequence is populated.
> Frame of Reference UID	(0020,0052)	Frame of Reference UID of the CT series used to define the structures and ROIs. Dataset must have in case of siemens and non siemens RT objects.
> Frame of Reference Relationship Sequence	(3006,00C0)	Not Supported.

RT Structure Set Module Table for VSim		
Attribute Name	Tag	Notes
>>Related Frame of Reference UID	(3006,00C2)	Not Supported.
>>Frame of Reference Transformation Type	(3006,00C4)	Not Supported.
>>Frame of Reference Transformation Matrix	(3006,00C6)	Not Supported.
>>Frame of Reference Transformation Comment	(3006,00C8)	Not Supported.
> RT Referenced Study Sequence	(3006,0012)	Reference to Study to which CT series belongs. Only one sequence is populated. Dataset must have in case of siemens and non siemens RT objects.
>> Referenced SOP Class UID	(0008,1150)	Study SOP Class UID as mentioned in the DICOM standard. Dataset must have in case of siemens and non siemens RT objects.
>> Referenced SOP Instance UID	(0008,1155)	Study SOP instance UID. Dataset must have in case of siemens and non siemens RT objects.
>>RT Referenced Series Sequence	(3006,0014)	Reference to CT series to which the CT images belong. Only one sequence is populated. Note: There is exactly one RT Structure Set referencing a CT image Series.
>>>Series Instance UID	(0020,000E)	SOP Instance UID of CT Series used to define the structures. Dataset must have in case of siemens and non siemens RT objects
>>>Contour Image Sequence	(3006,0016)	This is reference to the CT input images used in to define the Structure set.

RT Structure Set Module Table for VSim		
Attribute Name	Tag	Notes
>>>>Referenced SOP Class UID	(0008,1150)	CT Image SOP Class UID
>>>>Referenced SOP Instance UID	(0008,1155)	SOP Instance UID of CT image
>>>>Referenced Frame Number	(0008,1160)	Not Set.
Structure Set ROI Sequence	(3006,0020)	The sequence contains Structure Set ROI Sequence for all ROIs and Reference Points created by VSim. Dataset must have in case of siemens and non siemens RT objects.
> ROI Number	(3006,0022)	Integer number assigned during creation of ROI. Used to uniquely identify the corresponding ROI Contour and RT ROI Observations modules under a structure set. VSim ensures uniqueness of this attribute while creating ROIs. Dataset must have in case of siemens and non siemens RT objects.
> Referenced Frame of Reference UID	(3006,0024)	Frame of Reference UID of the CT series used for which ROI is defined. Dataset must have in case of siemens and non siemens RT objects.
> ROI Name	(3006,0026)	ROI or Reference Point name. Default names generated and set for ROI and points if not provided.
> ROI Description	(3006,0028)	Not Set.
> ROI Volume	(3006,002C)	Not Set.
> ROI Generation Algorithm	(3006,0036)	Always set to SEMIAUTOMATIC.

RT Structure Set Module Table for VSim

Attribute Name	Tag	Notes
> ROI Generation Description	(3006,0038)	Not Set.

ROI Contour Module Table for VSim

Attribute Name	Tag	Comments
ROI Contour Sequence	(3006,0039)	VSim creates/requires at least one ROI Contour module to be present in a Structure Set.
> Referenced ROI Number	(3006,0084)	An integer used to uniquely identify the ROI and its associated modules within a Structure Set. Dataset must have in case of siemens and non siemens RT objects.
> ROI Display Color	(3006,002A)	VSim expects/fills 3 integer values in the range 0-255. These values are interpreted as RGB components of display color. Sets default color to red if not provided.
> Contour Sequence	(3006,0040)	VSim stores the contour information in this attribute. For structures there can be zero or more contour sequences. For Reference Point, only one contour sequence is stored.
>> Contour Number	(3006,0048)	VSim stores a unique number within Contour Sequence (3006,0040).
>> Attached Contours	(3006,0049)	Not Set.
>> Contour Image Sequence	(3006,0016)	VSim passes this sequence for every contour sequence. Note: This is passed only for structures and not for reference points. Dataset must have in case of siemens and non siemens RT objects.
>>> Referenced SOP Class UID	(0008,1150)	CT Image SOP Class UID as defined in DICOM. Dataset must have in case of siemens and non siemens RT objects.

ROI Contour Module Table for VSim

Attribute Name	Tag	Comments
>>> Referenced SOP Instance UID	(0008,1155)	SOP Instance UID of the CT image on which the contour is drawn. Dataset must have in case of siemens and non siemens RT objects.
>>> Referenced Frame Number	(0008,1160)	VSim stores the default frame number of CT Image i.e., 0. CT images are not single frame images. Removed from copied structure set in case of non siemens RT objects.
>> Contour Geometric Type	(3006,0042)	VSim stores the geometry of contour. For Reference Points, the value is "POINT". For Structures or ROIs the value is always "CLOSED_PLANAR". VSim always creates closed planar contours. Dataset must have in case of siemens and non siemens RT objects.
>> Contour Slab Thickness	(3006,0044)	Not Set.
>> Contour Offset Vector	(3006,0045)	Not Set.
>> Number of Contour Points	(3006,0046)	VSim stores the number of contour points in the contour. Dataset must have in case of siemens and non siemens RT objects. Note: For Reference Point it is always 1.
>> Contour Data	(3006,0050)	VSim stores the contour data as sequence of triplets. (X, Y & Z coordinates of each point). Dataset must have in case of siemens and non siemens RT objects.

RT ROI Observations Module Table for VSim

Attribute Name	Tag	Comments
RT ROI Observations Sequence	(3006,0080)	VSim stores observation related to ROI / Reference Point. Dataset must have in case of siemens and non siemens RT objects
> Observation Number	(3006,0082)	Unique integer identifying the Observation within the Observation Sequence. VSim sets it equal to the Reference ROI Number (3006,0084) because, as of the current version, only one Observation is supported per ROI.
> Referenced ROI Number	(3006,0084)	An integer used to uniquely identify the ROI and its associated modules within a Structure Set. Dataset must have in case of siemens and non siemens RT objects.
> ROI Observation Label	(3006,0085)	VSim stores the name of the ROI/Reference Point (truncated to 16 characters) as set in the ROI Name(3006,0026) attribute of Structure Set ROI Sequence under RT Structure Set.
> ROI Observation Description	(3006,0088)	Not Set.
> RT Related ROI Sequence	(3006,0030)	Not Set.
>> Referenced ROI Number	(3006,0084)	Not Set.
>> RT ROI Relationship	(3006,0033)	Not Set.
> RT ROI Identification Code Sequence	(3006,0086)	Not Set
> Related RT ROI Observations Sequence	(3006,00A0)	Not Set
>> Observation Number	(3006,0082)	Not Set.

RT ROI Observations Module Table for VSim

Attribute Name	Tag	Comments
> RT ROI Interpreted Type	(3006,00A4)	<p>VSim stores the information about the type of ROI / Reference Point. VSim sets/interprets the following terms as:</p> <p>EXTERNAL, PTV, CTV, GTV, TREATED_VOLUME, IRRAD_VOLUME, BOLUS, AVOIDANCE, ORGAN, REGISTRATION, CONTRAST_AGENT, CAVITY, BRACHY_CHANNEL, BRACHY_ACCESSORY, BRACHY_SRC_APP, BRACHY_CHNL_SHLD - All these are structures.</p> <p>MARKER - Marked Reference Point ISOCENTER - Reference Point</p> <p>In case of non siemens RT objects if not provided is set to ORGAN if Contour Geometric Type (3006,0042) is CLOSED_PLANER and set to ISOCENTER if its POINT in copied structure set.</p>
> ROI Interpreter	(3006,00A6)	Not Set.
> Material ID	(300A,00E1)	Not Set.
> ROI Physical Properties Sequence	(3006,00B0)	<p>VSim stores the physical property associated of the ROI. Only one value for this SQ is supported if and only if the physical property is other then "CT." The value is always electron density relative to water.</p> <p>Also for Reference Points, this attribute is not set and should not be interpreted as default CT.</p>
>> ROI Physical Property	(3006,00B2)	<p>VSim always stores the ROI Physical Property Value (3006, 00B4) as electron density relative to water. Hence this attribute will always have the value "REL_ELEC_DENSITY"</p>
>> ROI Physical Property Value	(3006,00B4)	<p>A number set by the user as the physical property of the ROI. The following values should be interpreted as given below:</p> <p>1 - Water 0.19 - Air.</p> <p>Note: The attribute value has to be interpreted as electron density relative to water.</p>

RT General Plan Module Table for VSim

Attribute Name	Tag	Comments
RT Plan Label	(300A,0002)	VSim stores the name of the Plan in this attribute.
RT Plan Name	(300A,0003)	String containing the build and version information of VSim software used to create the structure set. Format: VSim x.y SL nnn Where x.y is the VSim version nnn- Build number. In case of non siemens RT objects set to same as VSim in the copied RT Plan.
Instance Number	(0020,0013)	VSim sets this attribute with an internally generated instance number.
Operator's Name	(0008,1070)	VSim sets the current user name as operator name in RT Series. This attribute is mapped on to the Operator name attribute of series.
RT Plan Date	(300A,0006)	VSim stores the last modification date of the plan. In case not provided set to system date.
RT Plan Time	(300A,0007)	VSim stores the last modification time of the plan. In case not provided set to system time.
Treatment Protocols	(300A,0009)	Not Set.
Treatment Intent	(300A,000A)	VSim always sets this attribute with the value "CURATIVE"
Treatment Sites	(300A,000B)	Not Set.
RT Plan Geometry	(300A,000C)	VSim always sets this attribute with the value "PATIENT". In case of non siemens RT objects "PATIENT" and "TREATMENT_DEVICE" are supported. if RT Plan Geometry is "TREATMENT_DEVICE" the plan should be based on single CT, single study, its converted to "PATIENT" based in the copied RT Plan.

RT General Plan Module Table for VSim

Attribute Name	Tag	Comments
Referenced Structure Set Sequence	(300C,0060)	VSim stores the RT Structure Set information, based on which the plan is designed/created. Only one value is set in this sequence. In case of non siemens RT objects ignored if RT Plan Geometry is "TREATMENT_DEVICE" the plan should be based on single CT, single study, and structure set reference is added when converted to "PATIENT" based in the copied RT Plan.
> Referenced SOP Class UID	(0008,1150)	SOP Class UID of structure set as defined in DICOM. In case of non siemens RT objects ignored if RT Plan Geometry is "TREATMENT_DEVICE" the plan should be based on single CT, single study, and structure set reference is added when converted to "PATIENT" based in the copied RT Plan.
> Referenced SOP Instance UID	(0008,1155)	VSim stores the SOP Instance UID of the Structure set used to create the plan. In case of non siemens RT objects ignored if RT Plan Geometry is "TREATMENT_DEVICE" the plan should be based on single CT, single study, and structure set reference is added when converted to "PATIENT" based in the copied RT Plan.
Referenced Dose Sequence	(300C,0080)	Not Set.
> Referenced SOP Class UID	(0008,1150)	Not Set.
> Referenced SOP Instance UID	(0008,1155)	Not Set.
Referenced RT Plan Sequence	(300C,0002)	Not Set.
> Referenced SOP Class UID	(0008,1150)	Not Set.
> Referenced SOP Instance UID	(0008,1155)	Not Set.

RT General Plan Module Table for VSim

Attribute Name	Tag	Comments
> RT Plan Relationship	(300A,0055)	Not Set.
> SIEMENS MED OCS BEAM DISPLAY INFO	(0039,XX76)	Private attribute stores beam number, beam color and beam group separated by “,” for a beam. The values for all beams are separated by “;”. Beam color is stored as RGB string. Beams are grouped having common isocenter.

RT Patient Setup Module Table for VSim

Attribute Name	Tag	Comments
Patient Setup Sequence	(300A,0180)	VSim stores the patient setup information for the following kinds of beams in the RT General Plan: Relative beams (includes SSD based relative beams) and absolute SSD based beams. If this module is present it is ignored (deleted) and recreated as per VSim specification for non-siemens RT objects.
> Patient Setup Number	(300A,0182)	VSim stores a number that is unique within a plan. Beams under the plan refer to this number for patient setup information (referenced Isocenter and table position information).
> Patient Position	(0018,5100)	VSim stores the patient position information as set in the CT series used to create the structure set.
> Patient Additional Position	(300A, 0184)	Not Set. Since Patient Position (0018, 5100) is set, VSim does not set this attribute.
> Fixation Device Sequence	(300A, 0190)	Not Set.
>> Fixation Device Type	(300A, 0192)	Not Set.
>> Fixation Device Label	(300A, 0194)	Not Set.

RT Patient Setup Module Table for VSim

Attribute Name	Tag	Comments
>> Fixation Device Description	(300A, 0196)	Not Set.
>> Fixation Device Position	(300A, 0198)	Not Set.
> Shielding Device Sequence	(300A, 01A0)	Not Set.
>> Shielding Device Type	(300A, 01A2)	Not Set.
>> Shielding Device Label	(300A, 01A4)	Not Set.
>> Shielding Device Description	(300A, 01A6)	Not Set.
>> Shielding Device Position	(300A, 01A8)	Not Set.
> Setup Technique	(300A,01B0)	VSim sets this attribute only in case of SSD based beams. In such cases the value set will be "FIXED_SSD"
> Setup Technique Description	(300A,01B2)	Not Set.
> Setup Device Sequence	(300A,01B4)	VSim uses this attribute to store the patient alignment information. This SQ attribute is filled if and only if the patient setup module under the plan is referenced by one or more Relative (or Relative-SSD) beams under the plan. VSim optimizes on the number of patient setup modules referenced by beams under a plan by keeping only one patient setup module for beams based on the same reference point and table position.
>> Setup Device Type	(300A,01B6)	VSim stores setup device for the patient alignment as "LASER_POINTER"
>> Setup Device Label	(300A,01B8)	Not Set.



RT Patient Setup Module Table for VSim

Attribute Name	Tag	Comments
>> Setup Device Description	(300A,01BA)	Not Set.
>> Setup Device Parameter	(300A,01BC)	VSim always sets this attribute to 0.
>> Setup Reference Description	(300A,01D0)	VSim uses this attribute to store the Marked Reference Point name used to align the patient.
> Table Top Vertical Setup displacement	(300A,01D2)	VSim stores table top vertical displacement from the specified Marked Reference point to obtain the beam isocenter. Note: This is filled only for relative beams.
> Table Top Longitudinal Setup displacement	(300A,01D4)	VSim stores Table top longitudinal displacement from the specified Marked Reference point to obtain the beam isocenter. Note: This is filled only for relative beams.
> Table Top Lateral Setup displacement	(300A,01D6)	VSim stores Table top lateral displacement from the specified Marked Reference point to obtain the beam isocenter. Note: This is filled only for relative beams.

RT Beam Module for VSim

Attribute Name	Tag	Comments
Beam Sequence	(300A,00B0)	VSim does not support plans without beams. At least one Beam module will exist under a plan.
> Beam Number	(300A,00C0)	VSim stores the beam number in this attribute. The beam number may be entered by the user or generated by the software. VSim generates only positive numbers in the range 1- 231 -1 as beam numbers. In case of non siemens RT objects beam number is generated if not provided.



RT Beam Module for VSim		
Attribute Name	Tag	Comments
> Beam Name	(300A,00C2)	VSim stores the beam number as it appears in (300A,00C0). In case of non siemens RT objects Beam Name is taken from Beam Name (300A,00C2) and set in Beam Description (300A,00C3) in the copied RT plan. Unique beam name is generated by setting Beam Number (300A,00C0) if Beam Name is not provided.
> Beam Description	(300A,00C3)	VSim uses this attribute to store the beam name. In case of non siemens RT objects name of beam is put in Beam Description.
> Beam Type	(300A,00C4)	VSim sets this values as "STATIC". Currently VSim creates/ supports STATIC beams only. In case of non siemens RT objects if beam type is "DYNAMIC" It is converted to "STATIC" only control points with index 0 and 1 are kept rest are removed.
> Radiation Type	(300A,00C6)	VSim creates/supports only "ELECTRON" and "PHOTON" beams as configured on the site.
> Treatment Machine Name	(300A,00B2)	VSim stores the name of the machine selected by the user to create the beam. Dataset must have in case of siemens and non siemens RT objects, if a machine with same name is not configured, the plan is rejected.
> Manufacturer	(0008,0070)	VSim stores the machine manufacturer's name in this attribute. The machine/equipment name used for beam delivery is read from configuration. This information is set at the time of configuring the machine. In case of non siemens RT objects set same as VSim.
> Institution Name	(0008,0080)	VSim stores the name of the Institution where the machine/equipment is located. This information is read from configuration set at the time of configuring the machine. In case of non siemens RT objects set same as VSim.



RT Beam Module for VSim		
Attribute Name	Tag	Comments
> Institution Address	(0008,0081)	Not Set.
> Institutional Department Name	(0008,1040)	Not Set.
> Manufacturer's Model Name	(0008,1090)	Not Set.
> Device Serial Number	(0018, 1000)	Not Set.
> Primary Dosimeter Unit	(300A, 00B3)	Not Set.
> Referenced Tolerance Number	(300C, 00A0)	Not Set.
> Source - Axis Distance	(300A,00B4)	VSim stores the Source to Axis Distance of the machine. This information is read from configuration set at the time of configuring the machine. In case of non siemens RT objects set to configured value in case of mismatch in the copied RT plan.
> Beam Limiting Device Sequence	(300A,00B6)	VSim uses this attribute to store the beam limiting device information. Information is read from configuration set at the time of configuring a machine. The number of SQs in this attribute depends on the number of BLDs in the machine. For each BLD a SQ exists under a beam. Required in case of siemens and non siemens RT objects. If extra sequence are present not supported by configured machine they are removed from the copied RT plan.

RT Beam Module for VSim		
Attribute Name	Tag	Comments
>> RT Beam Limiting Device Type	(300A,00B8)	<p>VSim uses this attribute to store the beam limiting device type. It can be one of:</p> <p>ASYMX ASYMY MLCX MLCY</p> <p>Required to be one of mentioned above in case of siemens and non siemens RT objects.</p>
>> Source to Beam Limiting Device Distance	(300A,00BA)	<p>VSim uses this attribute to store the source to beam limiting device distance.</p> <p>In case not provided set same as read from site configuration</p>
>> Number of Leaf/Jaw Pairs	(300A,00BC)	<p>VSim stores the number of BLD pairs information for a beam limiting device in this attribute. This is always read from site configuration. Required in case of siemens and non siemens RT objects and must match with the configured machine.</p>
>> Leaf Position Boundaries	(300A,00BE)	<p>VSim uses this attribute to store the leaf position boundaries ONLY. This information is stored only for MLC type beam limiting devices. In case not provided set same as read from site configuration.</p>
> Referenced Patient Setup Number	(300C,006A)	<p>VSim uses this attribute to store the patient setup number corresponding to the patient setup module containing the patient alignment information for the Relative beams and all SSD based beams. In case of non siemens RT objects set to created/recreated patient setup number.</p>
> Referenced Reference Image Sequence	(300C,0042)	<p>Sequence of referenced RT images used for validation of current beam.</p>
>> Referenced SOP Class UID	(0008,1150)	<p>RT image SOP Class UID as per DICOM.</p>



RT Beam Module for VSim		
Attribute Name	Tag	Comments
>> Referenced SOP Instance UID	(0008,1155)	SOP instance UID of referenced RT image for beam.
>> Reference Image Number	(300A,00C8)	RT image number generated internally for referenced RT image.
>> Start Cumulative Meterset Weight	(300C,0008)	Not Set.
>> End Cumulative Meterset Weight	(300C,0009)	Not Set.
> Planned Verification Image Sequence	(300A, 00CA)	Not Set.
>> Start Cumulative Meterset Weight	(300A,00C8)	Not Set.
>> Meterset Exposure	(3002,0032)	Not Set.
>> End Cumulative Meterset Weight	(300C,0009)	Not Set.
>> RT Image Plane	(3002,000C)	Not Set.
>> X-Ray Image Receptor Plane	(3002, 000E)	Not Set.
>> RT Image Orientation	(3002, 0010)	Not Set.
>> RT Image Position	(3002, 0012)	Not Set.
>> RT Image SID	(3002, 0026)	Not Set.
>> Imaging Device-Specific Acquisition Parameters	(300A, 00CC)	Not Set.
>> Referenced Reference Image Number	(300A, 0007)	Not Set.

RT Beam Module for VSim		
Attribute Name	Tag	Comments
> Treatment Delivery Type	(300A, 00CE)	
> Referenced Dose Sequence	(300C, 0080)	Not Set.
>> Referenced SOP Class UID	(0008, 1150)	Not Set.
>> Referenced SOP Instance UID	(0008, 1155)	Not Set.
> Number of Wedges	(300A, 00D0)	VSim stores always 0 as value.
> Wedge Sequence	(300A, 00D1)	Not Set. Since Number of Wedges (300A, 00D0) is set to 0, this SQ is not set.
>> Wedge Number	(300A, 00D2)	Not Set.
>> Wedge Type	(300A, 00D3)	Not Set.
>> Wedge ID	(300A, 00D4)	Not Set.
>> Wedge Angle	(300A, 00D5)	Not Set.
>> Wedge Factor	(300A, 00D6)	Not Set.
>> Wedge Orientation	(300A, 00D8)	Not Set.
>> Source to Wedge Tray Distance	(300A, 00DA)	Not Set.
> Number of Compensators	(300A, 00E0)	VSim stores always 0 as value.
> Total Tray Compensator Factor	(300A, 00E2)	Not Set.
> Compensator Sequence	(300A, 00E3)	Not Set. Since Number of Compensators (300A, 00E0) is set to 0, this SQ is not set.
>> Compensator Number	(300A, 00E4)	Not Set.



RT Beam Module for VSim		
Attribute Name	Tag	Comments
>> Compensator Type	(3004, 00EE)	Not Set.
>> Material ID	(300A, 00E1)	Not Set.
>> Compensator ID	(300A, 00E5)	Not Set.
>> Source to Compensator Tray Distance	(300A, 00E6)	Not Set.
>> Compensator Rows	(300A, 00E7)	Not Set.
>> Compensator Columns	(300A, 00E8)	Not Set.
>> Compensator Pixel Spacing	(300A, 00E9)	Not Set.
>> Compensator Position	(300A, 00EA)	Not Set.
>> Compensator Transmission Data	(300A, 00EB)	Not Set.
>> Compensator Thickness Data	(300A, 00EC)	Not Set.
> Number of Boli	(300A,00ED)	VSim stores always 0 as value.
> Referenced Bolus Sequence	(300C, 00B0)	Not Set. Since Number of Boli (300A, 00ED) is set to 0, this SQ is not set.
>> Referenced ROI Number	(3006, 0084)	Not Set.
> Number of Blocks	(300A, 00F0)	VSim stores the number of blocks/ports for the current beam. This information is only for HPD machines (machines with only jaws as beam limiting device). For all other machines (machines with beam limiting device as MLC, or both MLC and jaws) value stored is 0 as they do not support blocks.

RT Beam Module for VSim		
Attribute Name	Tag	Comments
> Total Block Tray Factor	(300A, 00F2)	Not Set.
> Block Sequence	(300A, 00F4)	VSim stores the block data for HPD machines having one or more number of blocks. For MLC machines this SQ attribute is not set. VSim expects the Block type (300A, 00F8) to be same for all blocks under the sequence.
>> Block Tray ID	(300A,00F5)	Not Set.
>>>Source to Block Tray Distance	(300A, 00F6)	VSim stores the source to block tray distance in this attribute. This information is read from configuration set at the time of configuring a machine.
>>> Block Type	(300A, 00F8)	VSim stores the following values: SHIELDING - for blocks APERTURE - for ports
>>> Block Divergence	(300A, 00FA)	VSim always sets the value "ABSENT"
>>> Block Number	(300A, 00FC)	VSim generates a unique number under the beam for this attribute.
>>> Block Name	(300A, 00FE)	Not Set.
>>> Material ID	(300A, 00E1)	Not Set.
>>> Block Thickness	(300A, 0100)	VSim always sets the value 0
>>> Block Transmission	(300A, 0102)	VSim always sets the value 0
>>> Block Number of Points	(300A, 0104)	Number of points present in the contour drawn for block/port
>>> Block Data	(300A, 0106)	Actual contour data drawn by user.
> Applicator Sequence	(300A, 0107)	Not Set.
>>> Applicator ID	(300A, 0108)	Not Set.
>>> Applicator Type	(300A, 0109)	Not Set.



RT Beam Module for VSim		
Attribute Name	Tag	Comments
>> Applicator Description	(300A, 010A)	Not Set.
> Final Cumulative Meterset Weight	(300A,010E)	VSim always stores 1, so that the cumulative meterset weight is equal to the fraction of the beam meterset delivered at each control point.
> Number of Control Points	(300A,0110)	Since VSim creates only STATIC beams, the value is set to 2. In case of non siemens RT objects only first two control points will be read.
> Control Point Sequence	(300A,0111)	Contains exactly 2 control points. All Control Point parameters are set for 1st control point. 2nd control point contains, only, Control Point index and Cumulative meterset weight. Dataset must have in case of siemens and non siemens RT objects.
>> Control Point Index	(300A,0112)	0 for 1st control point and 1 for 2nd control point. Dataset must have in case of siemens and non siemens RT objects
>> Cumulative Meterset Weight	(300A,0134)	The first control point always has a cumulative meterset weight set to zero (0). Because VSim creates only STATIC beams, the second control point always has a cumulative meterset weight equal to the final cumulative meterset weight (300A,010E).
>> Referenced Dose Reference Sequence	(300C, 0050)	Not Set.
>>> Referenced Dose Reference Number	(300C, 0051)	Not Set.
>>> Cumulative Dose Reference Coefficient	(300A, 010C)	Not Set.
>> Nominal Beam Energy	(300A,0114)	Default is set as configured for a machine or set to the value entered by user. In case of non siemens RT objects energy will be taken from the first control point.



RT Beam Module for VSim		
Attribute Name	Tag	Comments
>> Dose Rate Set	(300A,0115)	Not Set.
>> Wedge Position Sequence	(300A, 0116)	Not Set.
>>> Referenced Wedge Number	(300A, 00C0)	Not Set.
>>> Wedge Position	(300A,0118)	Not Set.
>> Beam Limiting Device Position Sequence	(300A,011A)	BLD sequence which represents the actual values. Dataset must have in case of siemens and non siemens RT objects.
>>> RT Beam Limiting Device Type	(300A,00B8)	Set as per the machine configuration
>>> Leaf/Jaw Positions	(300A,011C)	Actual positions as they appear in the UI (BEV or edit beam dialog)
>> Gantry Angle	(300A,011E)	Gantry angle as set by user
>> Gantry Rotation Direction	(300A,011F)	NONE
>> Beam Limiting Device Angle	(300A,0120)	As set by user
>> Beam Limiting Device Rotation Direction	(300A,0121)	NONE
>> Patient Support Angle	(300A,0122)	Patient Support Angle as set by user
>> Patient Support Rotation Direction	(300A,0123)	NONE
>> Table Top Eccentric Axis Distance	(300A,0124)	0



RT Beam Module for VSim

Attribute Name	Tag	Comments
>> Table Top Eccentric Angle	(300A,0125)	Read from registry and set
>> Table Top Eccentric Rotation Direction	(300A,0126)	NONE
>> Table Top Vertical Position	(300A,0128)	Table top vertical position set if beam is not relative
>> Table Top Longitudinal Position	(300A,0129)	Table top longitudinal position is set if beam is not relative
>> Table Top Lateral Position	(300A,012A)	Table top lateral position is set if beam is not relative
>> Isocenter Position	(300A,012C)	Beam isocenter position in patient coordinate system.
>> Surface Entry Point	(300A,012E)	Set if external ROI is present along the beam axis.
>> Source to Surface Distance	(300A,0130)	Set if external ROI is present along beam axis, other wise 0 is set.

RT Image Module Table for VSim

Attribute Name	Tag	Comments
Samples per Pixel	(0028, 0002)	1
Photometric Interpretation	(0028, 0004)	MONOCHROME2
Bits Allocated	(0028, 0100)	16
Bits Stored	(0028, 0101)	12
High Bit	(0028, 0102)	11 (Bits Stored - 1)
Pixel Representation	(0028, 0103)	0000H (unsigned integer)
RT Image Label	(3002, 0002)	Beam name to which RT Image refers.

RT Image Module Table for VSim

Attribute Name	Tag	Comments
RT Image Name	(3002, 0003)	
RT Image Description	(3002, 0004)	Not Set.
Image Type	(0008, 0008)	“DERIVED/ SECONDARY/DRR”
Conversion Type	(0008, 0064)	WSD
Reported Values Origin	(3002, 000A)	Not Set.
RT Image Plane	(3002, 000C)	NORMAL
X-Ray Image Receptor Translation	(3002, 000D)	Not Set.
X-Ray Image Receptor Angle	(3002, 000E)	Not Set.
Image Plane Pixel Spacing	(3002,0011)	Set as per DRR calculator parameters' X and Y resolution Formula: Machine Iso-field size/.512. Iso-field size is obtained from configuration set at the time of configuring the system.
RT Image Position	(3002,0012)	Not Set.
Radiation Machine Name	(3002,0020)	Machine name for which beam is created
Primary Dosimeter Unit	(300A, 00B3)	Not Set.
Radiation Machine SAD	(3002,0022)	Set as configured for a machine for which beam (DRR) is created
Radiation Machine SSD	(3002,0024)	Copied from control point value of the beam
RT Image SID	(3002,0026)	VSim sets this equal to the Radiation Machine SAD (3002,0022).
Source to Reference Object Distance	(3002, 0028)	Not Set.
Referenced RT Plan Sequence	(300C,0002)	RT Plan to which the RT Image belongs



RT Image Module Table for VSim		
Attribute Name	Tag	Comments
> Referenced SOP Class UID	(0008,1150)	SOP Class UID of RT General Plan as defined in DICOM
> Referenced SOP Instance UID	(0008,1155)	SOP Instance UID of the Plan to which the RT Image belongs
Referenced Beam Number	(300C,0006)	Beam number for which DRR is generated
Referenced Fraction Group Number	(300C, 0022)	Not Set.
Fraction Number	(3002, 0029)	Not Set.
Start Cumulative Meterset Weight	(300C,0008)	0
End Cumulative Meterset Weight	(300C,0009)	1
Exposure Sequence	(3002,0030)	VSim creates 1 instance of Exposure Sequence containing the Block Sequence and Beam Limiting Device Sequence.
> Referenced Frame Number	(0008, 1160)	Not Set.
>> KVP	(0018, 0060)	Not Set.
> X-Ray Tube Current	(0018, 0051)	Not Set.
>> Exposure Time	(0018, 0050)	Not Set
> Meterset Exposure	(3002, 0032)	Not Set
> Diaphragm Position	(3002, 0034)	Not Set

RT Image Module Table for VSim

Attribute Name	Tag	Comments
> Beam Limiting Device Sequence	(300A,00B6)	VSim uses this attribute to store the beam limiting device information. Information is read from configuration set at the time of configuring a machine. The number of SQs in this attribute depends on the number of BLDs in the machine. For each BLD a SQ exists under a beam. This information is copied from the corresponding beam.
>> RT Beam Limiting Device Type	(300A,00B8)	VSim uses this attribute to store the beam limiting device type. It can be one of: ASYMX ASYMY MLCX MLCY This information is copied from the corresponding beam.
>> Source to Beam Limiting Device Distance	(300A,00BA)	VSim uses this attribute to store the source to beam limiting device distance.
>> Number of Leaf/Jaw Pairs	(300A,00BC)	VSim stores the number of BLD pairs information for a beam limiting device in this attribute. This information is copied from the corresponding beam.
>> Leaf Position Boundaries	(300A,00BE)	VSim uses this attribute to store the leaf position boundaries ONLY. This information is stored only for MLC type beam limiting devices. This information is copied from the corresponding beam.
> Beam Limiting Device Sequence	(300A,00B6)	VSim uses this attribute to store the beam limiting device information. Information is read from configuration set at the time of configuring a machine. The number of SQs in this attribute depends on the number of BLDs in the machine. For each BLD a SQ exists under a beam. This information is copied from the corresponding beam.
> Applicator Sequence	(300A, 0107)	Not Set.

RT Image Module Table for VSim

Attribute Name	Tag	Comments
>> Applicator ID	(300A, 0108)	Not Set.
>> Applicator Type	(300A, 0109)	Not Set.
>> Applicator Description	(300A, 010A)	Not Set.
> Number of Blocks	(300A, 00F0)	This information is copied from the corresponding beam.
> Block Sequence	(300A, 00F4)	This information is copied from the corresponding beam.
>> Block Tray ID	(300A,00F5)	Not Set.
>>Source to Block Tray Distance	(300A, 00F6)	This information is copied from the corresponding beam.
>> Block Type	(300A, 00F8)	This information is copied from the corresponding beam.
>> Block Divergence	(300A, 00FA)	This information is copied from the corresponding beam.
>> Block Number	(300A, 00FC)	This information is copied from the corresponding beam.
>> Block Name	(300A, 00FE)	Not Set.
>> Material ID	(300A, 00E1)	Set to empty.
>> Block Thickness	(300A, 0100)	VSim always sets the value 0
Gantry Angle	(300A, 011E)	This information is copied from the corresponding beam.
Beam Limiting Device Angle	(300A, 0120)	This information is copied from the corresponding beam.
Patient Support Angle	(300A, 0122)	This information is copied from the corresponding beam.

RT Image Module Table for VSim

Attribute Name	Tag	Comments
Table Top Eccentric Axis Distance	(300A, 0124)	This information is copied from the corresponding beam.
Table Top Eccentric Angle	(300A, 0125)	This information is copied from the corresponding beam.
Table Top Vertical Position	(300A, 0128)	This information is copied from the corresponding beam.
Table Top Longitudinal Position	(300A, 0129)	This information is copied from the corresponding beam.
Table Top Lateral Position	(300A, 012A)	This information is copied from the corresponding beam.

Privatizations

Private Elements for Storage SOP Classes

The following private attributes are defined for all Siemens *syngo* based applications:

Registry of DICOM Data Elements

Tag	Private Owner Code	Name	VR	VM
(0029,xx08)	SIEMENS CSA HEADER	CSA Image Header Type	CS	1
(0029,xx09)	SIEMENS CSA HEADER	CSA Image Header Version	LO	1
(0029,xx10)	SIEMENS CSA HEADER	CSA Image Header Info	OB	1
(0029,xx18)	SIEMENS CSA HEADER	CSA Series Header Type	CS	1
(0029,xx19)	SIEMENS CSA HEADER	CSA Series Header Version	LO	1
(0029,xx20)	SIEMENS CSA HEADER	CSA Series Header Info	OB	1
(0029,xx08)	SIEMENS CSA NON-IMAGE	CSA Data Type	CS	1
(0029,xx09)	SIEMENS CSA NON-IMAGE	CSA Data Version	LO	1
(0029,xx10)	SIEMENS CSA NON-IMAGE	CSA Data Info	OB	1
(0029,xx08)	SIEMENS CSA REPORT	<i>syngo</i> Report Type	CS	1
(0029,xx09)	SIEMENS CSA REPORT	<i>syngo</i> Report	LO	1
(0029,xx15)	SIEMENS CSA REPORT	SR Variant	US	1
(0029,xx17)	SIEMENS CSA REPORT	SC SOP Instance UID	UI	1
(0029,xx10)	SIEMENS CSA ENVELOPE	<i>syngo</i> Report Data	OB	1
(0029,xx11)	SIEMENS CSA ENVELOPE	<i>syngo</i> Report Presentation	OB	1
(0029,xx08)	SIEMENS MEDCOM HEADER	MedCom Header Type	CS	1
(0029,xx09)	SIEMENS MEDCOM HEADER	MedCom Header Version	LO	1
(0029,xx10)	SIEMENS MEDCOM HEADER	MedCom Header Info	OB	1

Tag	Private Owner Code	Name	VR	VM
(0029,xx20)	SIEMENS MEDCOM HEADER	MedCom History Information	OB	1
(0029,xx31)	SIEMENS MEDCOM HEADER	PMTF Information 1	LO	1
(0029,xx32)	SIEMENS MEDCOM HEADER	PMTF Information 2	UL	1
(0029,xx33)	SIEMENS MEDCOM HEADER	PMTF Information 3	UL	1
(0029,xx34)	SIEMENS MEDCOM HEADER	PMTF Information 4	CS	1
(0029,xx35)	SIEMENS MEDCOM HEADER	PMTF Information 5	UL	1
(0029,xx40)	SIEMENS MEDCOM HEADER	Application Header Sequence	SQ	1
(0029,xx41)	SIEMENS MEDCOM HEADER	Application Header Type	CS	1
(0029,xx42)	SIEMENS MEDCOM HEADER	Application Header ID	LO	1
(0029,xx43)	SIEMENS MEDCOM HEADER	Application Header Version	LO	1
(0029,xx44)	SIEMENS MEDCOM HEADER	Application Header Info	OB	1
(0029,xx50)	SIEMENS MEDCOM HEADER	Workflow Control Flags	LO	8
(0029,xx51)	SIEMENS MEDCOM HEADER	Archive Management Flag Keep Online	CS	1
(0029,xx52)	SIEMENS MEDCOM HEAD	Archive Management Flag Do Not Archive	CS	1
(0029,xx53)	SIEMENS MEDCOM HEADER	Image Location Status	CS	1
(0029,xx54)	SIEMENS MEDCOM HEADER	Estimated Retrieve Time	DS	1
(0029,xx55)	SIEMENS MEDCOM HEADER	Data Size of Retrieved Images	DS	1
(0029,xx70)	SIEMENS MEDCOM HEADER	Siemens Link Sequence	SQ	1
(0029,xx71)	SIEMENS MEDCOM HEADER	Referenced Tag	AT	1
(0029,xx72)	SIEMENS MEDCOM HEADER	Referenced Tag Type	CS	1
(0029,xx73)	SIEMENS MEDCOM HEADER	Referenced Value Length	UL	1
(0029,xx74)	SIEMENS MEDCOM HEADER	Referenced Object Device Type	CS	1
(0029,xx75)	SIEMENS MEDCOM HEADER	Referenced Object Device Location	OB	1

Tag	Private Owner Code	Name	VR	VM
(0029,xx76)	SIEMENS MEDCOM HEADER	Referenced Object ID	OB	1
(0029,xx60)	SIEMENS MEDCOM HEADER2	Series Work Flow Status	LO	1
(0029,xx08)	SIEMENS MEDCOM OOG	MEDCOM OOG Type	CS	1
(0029,xx09)	SIEMENS MEDCOM OOG	MEDCOM OOG Version	LO	1
(0029,xx10)	SIEMENS MEDCOM OOG	MEDCOM OOG Info	OB	1
(7FE1,xx10)	SIEMENS CSA NON-IMAGE	CSA Data	OB	1

The next subsections will explain in which IODs these private data elements are used.

All syngo Supported Image SOP Classes

**Extended Image IOD Module
Table**

IE	Module	Reference	Usage	Note
Patient	Patient	part3 C.7.1.1	M	
Study	General Study	part3 C.7.2.1	M	
	Patient Study	part3 C.7.2.2	U	
Series	General Series	part3 C.7.3.1	M	
Equipment	General Equipment	part3 C.7.5.1	U	
Image	General Image	part3 C.7.6.1	M	
	Image Pixel	part3 C.7.6.3	M	
	IOD specific modules	part3 C.8.2.1	M/U	depends on the IOD
	CSA Image Header	→ page A.4–81	U	
	CSA Series Header	→ page A.4–81	U	
	MEDCOM Header	→ page A.4–82	U	private <i>syngo</i> information
	MEDCOM OOG	→ page A.4–87	U	if object graphics is attached to image
	SOP Common	part3 C.12.1	M	

CSA Image Header Module The table in this section contains private IOD Attributes that describe the CSA Image Header.

Attribute Name	Tag	Private Creator	Type	Notes
CSA Image Header Type	(0029,xx08)	SIEMENS CSA HEADER	1	CSA Image Header identification characteristics. Defined Terms: NUM 4 = NUMARIS/4 SOM 5 = Somaris/5
CSA Image Header Version	(0029,xx09)	SIEMENS CSA HEADER	3	Version of CSA Image Header Info (0029,xx10) format.
CSA Image Header Info	(0029,xx10)	SIEMENS CSA HEADER	3	Manufacturer Model dependent information.

CSA Series Header Module The table in this section contains private IOD Attributes that describe the CSA Series Header.

Attribute Name	Tag	Private Creator	Type	Notes
CSA Series Header Type	(0029,xx18)	SIEMENS CSA HEADER	1	CSA Series Header identification characteristics. Defined Terms: NUM 4 = NUMARIS/4 SOM 5 = Somaris/5
CSA Series Header Version	(0029,xx19)	SIEMENS CSA HEADER	3	Version of CSA Series Header Info (0029,xx20) format.
CSA Series Header Info	(0029,xx20)	SIEMENS CSA HEADER	3	Manufacturer Model dependent information.

MEDCOM Header Module The table in this section contains private IOD Attributes that describe MEDCOM Header.

Attribute Name	Tag	Private Creator	Type	Notes
MedCom Header Type	(0029,xx08)	SIEMENS MEDCOM HEADER	1C	MedCom Header identification characteristics. Defined Terms: MEDCOM 1 Required if MedCom Header Info (0029,xx10) present.
MedCom Header Version	(0029,xx09)	SIEMENS MEDCOM HEADER	2C	Version of MedCom Header Info (0029,xx10) format. Required if MEDCOM Header Info (0029,xx10) present.
MedCom Header Info	(0029,xx10)	SIEMENS MEDCOM HEADER	3	Manufacturer model dependent information. The value of the attribute MedCom Header Info (0029,xx10) can be build up in each user defined format.
MedCom History Information	(0029,xx20)	SIEMENS MEDCOM HEADER	3	MedCom defined Patient Registration history information. See → page A.4–87.
PMTF Information 1	(0029,xx31)	SIEMENS MEDCOM HEADER	3	Transformation Information
PMTF Information 2	(0029,xx32)	SIEMENS MEDCOM HEADER	3	Transformation Information
PMTF Information 3	(0029,xx33)	SIEMENS MEDCOM HEADER	3	Transformation Information

Attribute Name	Tag	Private Creator	Type	Notes
PMTF Information 4	(0029,xx34)	SIEMENS MEDCOM HEADER	3	Transformation Information
Application Header Sequence	(0029,xx40)	SIEMENS MEDCOM HEADER	3	Sequence of Application Header Items. Zero or more Items shall be included in this sequence. Encoded as a sequence of items.
> Application Header Type	(0029,xx41)	SIEMENS MEDCOM HEADER	1C	Application Header identification characteristics. Required if Sequence is sent.
> Application Header ID	(0029,xx42)	SIEMENS MEDCOM HEADER	3	Identification of an application header.
> Application Header Version	(0029,xx43)	SIEMENS MEDCOM HEADER	3	Version of Application Header Info (0029,xx43) format.
> Application Header Info	(0029,xx44)	SIEMENS MEDCOM HEADER	3	Application dependent information.
Workflow Control Flags	(0029,xx50)	SIEMENS MEDCOM HEADER	3	Eight free definable flags.
Archive Management Flag Keep Online	(0029,xx51)	SIEMENS MEDCOM HEADER	3	Flag to control remote archive management system to keep the image always online (also when already archived). Enumerated Values: 00 = remote control not required, 01 = keep image online.

Attribute Name	Tag	Private Creator	Type	Notes
Archive Management Flag Do Not Archive	(0029,xx52)	SIEMENS MEDCOM HEADER	3	Flag to control remote archive management system not to archive the related image. Enumerated Values: 00 = remote control not required, 01 = don't archive image.
Image Location Status	(0029,xx53)	SIEMENS MEDCOM HEADER	3	Image location status to control retrieving. Defined Terms: ONLINE = retrieving has to be done as usual, NEARLINE = move request to SCP and delay according to value of Estimated Retrieve Time (0029,xx54), OFFLINE = invoking a retrieve operation initiates an operator request, INVALID = invoking a retrieve operation would always result in an error.
Estimated Retrieve Time	(0029,xx54)	SIEMENS MEDCOM HEADER	3	Estimated retrieve time in seconds. A value less than zero (< 0) indicates location is OFFLINE or INVALID.
Data Size of Retrieved Images	(0029,xx55)	SIEMENS MEDCOM HEADER	3	Data size of images in MByte.
Siemens Link Sequence	(0029,xx70)	SIEMENS MEDCOM HEADER	3	Sequence of Link items. Each item identifies the location of one missing tag. One or more items can be located in this sequence.
Referenced Tag	(0029,xx71)	SIEMENS MEDCOM HEADER	1	The referenced tag. The value of this tag is in the Child Data Object (CDO). Currently it is always Pixel Data (7FE0,0010).

Attribute Name	Tag	Private Creator	Type	Notes
Referenced Tag Type	(0029,xx72)	SIEMENS MEDCOM HEADER	1	The value representation (type) of the missing tag (e.g. OW). Enumerated values are all DICOM defined Value Representations.
Referenced Value Length	(0029,xx73)	SIEMENS MEDCOM HEADER	1	The length of the referenced tag value in bytes.
Referenced Object Device Type	(0029,xx74)	SIEMENS MEDCOM HEADER	1	The Device Type that stores the Child Data Object (CDO) with the referenced tag value. Currently it should be "SHMEM". In future, "SDM", "LOID" or "FILE" are also imaginable. Defined Terms are SHMEM = Shared Memory SDM = Series Data Management LOID = Database FILE
Referenced Object Device Location	(0029,xx75)	SIEMENS MEDCOM HEADER	2	The Location of the device that stores the Child Data Object (CDO) with the referenced tag value. For the "SHMEM" case, it is the shared memory directory. Can be empty, then the default directory will be taken. In future, for "SDM" this will be the SDM_ID, for FILE it will be the directory name and for "LOID" it will be the database name.

Attribute Name	Tag	Private Creator	Type	Notes
Referenced Object ID	(0029,xx76)	SIEMENS MEDCOM HEADER	1	The ID of the object that contains the Child Data Object (CDO) with the referenced tag value. In case of "SHMEM", it is the shared memory ID. In future, for "SDM" this will be a Sirius OID, for "FILE" the file name, for "DB" the LOID.
Series Work Flow Status	(0029,xx60)	SIEMENS MEDCOM HEADER	3	syngo Patient Browser specific flags used for clinical work: - com = completed - rea = read - ver = verified

MEDCOM History Information

The value of the attribute MEDCOM History Information (0029,xx20) is defined in the following way:

Part	Name	Type	Bytes	Notes
header	Identifier	string	32	always "CSA HISTORY"
	Version	string	32	e.g. "V1.10"
n items	Class Name	string	64	
	Modification String	string	1024	

MEDCOM OOG Module

The table in this section contains private IOD Attributes that describe MEDCOM Object Oriented Graphics (OOG). This module is used when object graphics is drawn on the image and need to be stored as graphic object properties (Line, Circle, Rectangle, Arrow, and so on). Even the condition that the module contents was not removed by other modalities, the graphic objects remain re-animatable if such an image was transferred and is then retrieved back.

Attribute Name	Tag	Private Creator	Type	Notes
MedCom OOG Type	(0029,xx08)	SIEMENS MEDCOM OOG	1	MEDCOM Object Oriented Graphics (OOG) identification characteristics. Defined Terms: MEDCOM OOG 1
MedCom OOG Version	(0029,xx09)	SIEMENS MEDCOM OOG	3	Version of MEDCOM OOG Info (0029,xx10) format.
MedCom OOG Info	(0029,xx10)	SIEMENS MEDCOM OOG	3	MEDCOM Object Oriented Graphics (OOG) data.

The graphics objects are also stored in one Image overlay plane for compatibility with other products, which don't support the MedCom OOG module. Any system which does not support this MedCom OOG module has to remove these private attributes when modifying the image overlay plane content.

syngo Report Data

The module contains private IOD Attributes that describe *syngo* reports. This module is used when *syngo* report data are added to DICOM SR and DICOM SC objects.

Attribute Name	Tag	Private Creator	Type	Notes
<i>syngo</i> Report Type	(0029,xx08)	SIEMENS CSA REPORT	1	<i>syngo</i> report characteristics, e.g. report creating application. Defined Terms: CT_CASCORING CT_CIRCULATION CT_LUNGCARE INSPACE MR_ARGUS This attribute value will be used to identify the corresponding application during generic extension dll management. A restricted character set is used: only A-Z and underscore are supported.
<i>syngo</i> Report Version	(0029,xx09)	SIEMENS CSA REPORT	3	Version of <i>syngo</i> Report Data (0029,xx10) format.
<i>syngo</i> Report Data	(0029,xx10)	SIEMENS CSA ENVELOPE	3	Application specific report related data
<i>syngo</i> Report Presentation	(0029,xx11)	SIEMENS CSA ENVELOPE	3	Application specific report related data

Attribute Name	Tag	Private Creator	Type	Notes
SR Variant	(0029,xx15)	SIEMENS CSA REPORT		DICOM SR Variant. Enumerated Values: 0 = Basic Text SR (1.2.840.1008.5.1.4.1.1.88.11) 1 = Enhanced SR (1.2.840.1008.5.1.4.1.1.88.22) 2 = Comprehensive SR (1.2.840.1008.5.1.4.1.1.88.33) 3 = Mammography CAD SR (1.2.840.1008.5.1.4.1.1.88.50) 4 = Key Object Selection Document (1.2.840.1008.5.1.4.1.1.88.59) 5 = Chest CAD SR (1.2.840.1008.5.1.4.1.1.88.65)
SC SOP Instance UID	(0029,xx17)	SIEMENS CSA REPORT	3	DICOM SOP Instance UID of syngo based SC image representing the syngo report object. This UID will be used to identify the Resulting SC object after SR to SC conversion.

Private Elements for CT Image Storage SOP Classes

The following private attributes are defined by Somaris/5.

Registry of DICOM Data Elements

Tag	Private Owner Code	Name	VR	VM	Notes
(0019,xx90)	SIEMENSCTVA0COAD	Osteo Offset	DS	1	Offset of the water equivalent material of the Siemens Osteo phantom to real water
(0019,xx92)	SIEMENSCTVA0COAD	Osteo Regression Line Slope	DS	1	Slope of the regression line for the ESP (=European Spine Phantom) standardization
(0019,xx93)	SIEMENSCTVA0COAD	Osteo Regression Line Intercept	DS	1	Intercept of the regression line for the ESP (= European Spine Phantom) standardization
(0019,xx96)	SIEMENSCTVA0COAD	Osteo Phantom Number	IS	1	Number of the Siemens Osteo phantom
(0019,xxB0)	SIEMENSCTVA0COAD	Feed per Rotation	DS	1	Som/4 style Feed per Rotation (Backwards Compatibility)
(0019,xxBD)	SIEMENSCTVA0COAD	Pulmo Trigger Level	IS	1	Spirometer trigger level used for the scan, given in percent of VC (= Vital Capacity) of the patient

Tag	Private Owner Code	Name	VR	VM	Notes
(0019,xxBE)	SIEMENSCTVA0COAD	Expiratoric Reserve Volume	DS	1	ERV (= Expiratoric Reserve Volume) achieved by the patient
(0019,xxBF)	SIEMENSCTVA0COAD	Vital Capacity	DS	1	VC (= Vital Capacity) achieved by the patient
(0019,xxC0)	SIEMENSCTVA0COAD	Pulmo Water	DS	1	Density of the water insert of the Siemens Pulmo phantom
(0019,xxC1)	SIEMENSCTVA0COAD	Pulmo Air	DS	1	Density of the air holes of the Siemens Pulmo phantom
(0019,xxC2)	SIEMENSCTVA0COAD	Pulmo Date	DA	1	Date of the evaluation of the Siemens Pulmo phantom
(0019,xxC3)	SIEMENSCTVA0COAD	Pulmo Time	TM	1	Time of the evaluation of the Siemens Pulmo phantom
(0021xx11)	SIEMENS MED	Target	DS	2	Som/4 style Target (Backwards Compatibility)
(0009,00xx)	SIEMENS CT VA1 DUMMY	Private Creator Data Element	LO	1	1

Private SOP class CSA Non-Image

This chapter includes the definition of the Siemens AG B Med CSA defined private Non-Image Object (called CsaNonImage IOD). The focus of this private Non-Image Object is to address the requirement for non-image data sets found in *syngo* based applications.

The MedCom Non-Image Information Object Definition specifies data sets that are converted from a non-DICOM format to a modality independent DICOM format.

Examples of such manufacturer model dependent data sets are:

- Raw Data
- CT Admin Data
- MR Spectroscopy Data
- etc.

CSA Non-Image IOD Entity Relationship Model

The E-R model in [DICOM] A.1.2 depicts those components of the DICOM Information Model which directly refer to the CSA Non-Image IOD. The frame of reference IE, overlay IE, modality look up table IE, VOI lookup table IE and curve IE are not components of the CSA Non-Image IOD.

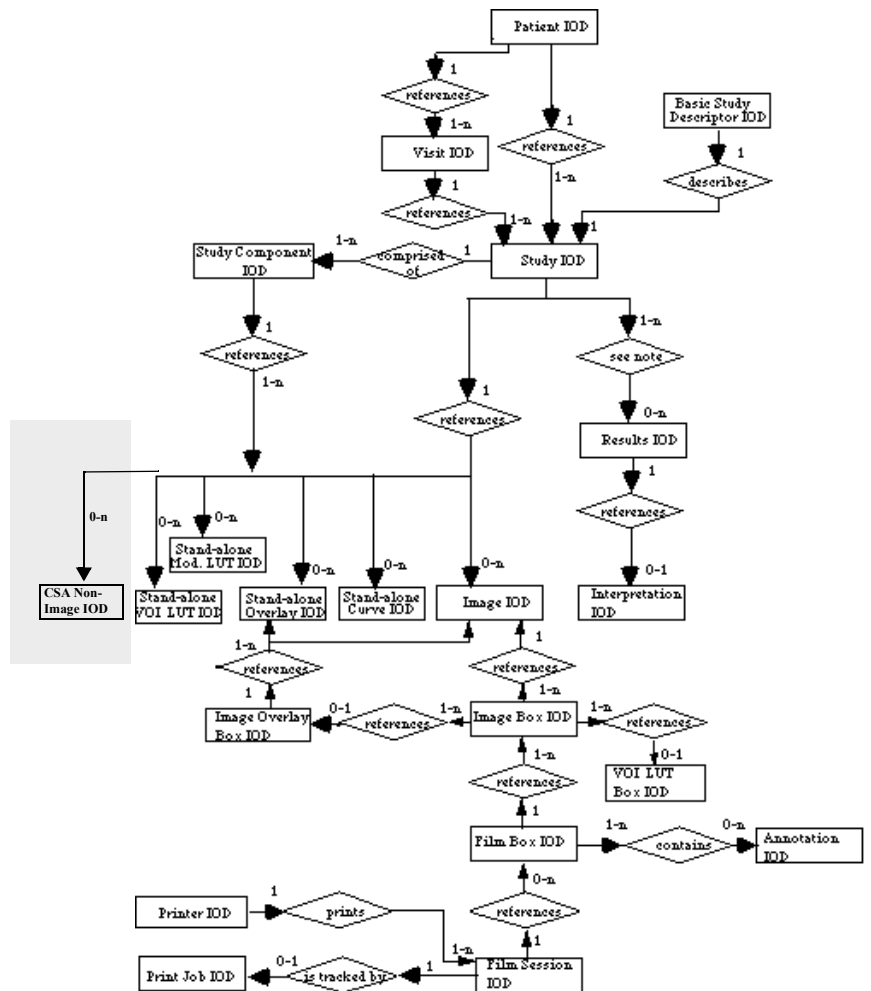

CSA Non-Image IOD Module Table

IE	Module	Reference	Usage
Patient	Patient	part 3 C.7.1.1	M
Study	General Study	part 3 C.7.2.1	M
	Patient Study	part 3 C.7.2.2	U
Series	General Series	part 3 C.7.3.1	M
Equipment	General Equipment	part 3 C.7.5.1	U
CSA	CSA Image Header	→ page A.4–81	U
	CSA Series Header	→ page A.4–81	U
	MEDCOM Header	→ page A.4–82	U
	MEDCOM OOG	→ page A.4–87	U
	CSA Non-Image	→ page A.4–95	M
	SOP Common	part 3 C.12.1	M

CSA Non-Image Module

The table in this section contains private IOD Attributes that describe CSA Non-Images.

Attribute Name	Tag	Private Creator	Type	Notes
Image Type	(0008,0008)	-	3	Image identification characteristics. See → page A.4–98
Acquisition Date	(0008,0022)	-	3	The date the acquisition of data that resulted in this data set started.
Acquisition Time	(0008,0032)	-	3	The time the acquisition of data that resulted in this data set started.
Conversion Type	(0008,0064)	-	3	Describes the kind of image conversion. Defined Terms: DV = Digitized Video, DI = Digital Interface, DF = Digitized Film, WSD = Workstation.
Referenced Image Sequence	(0008,1140)	-	3	A sequence which provides reference to a set of Image SOP Class/Instance identifying other images significantly related to this data set. Encoded as sequence of items: (0008,1150) and (0008,1155).
Derivation Description	(0008,2111)	-	3	A text description of how this data set was derived.
Source Image Sequence	(0008,2112)	-	3	A Sequence which identifies the set of Image SOP Class/Instance pairs of the Images which were used to derive this data set. Zero or more Items may be included in this Sequence. Encoded as sequence of items: (0008,1150) and (0008,1155).

Attribute Name	Tag	Private Creator	Type	Notes
Patient Position	(0018,5100)	-	3	Patient position descriptor relative to the equipment.
Acquisition Number	(0020,0012)	-	3	A number identifying the gathering of data over a period of time which resulted in this data set.
Instance Number	(0020,0013)	-	3	A number that identifies this data set.
Frame of Reference UID	(0020,0052)	-	3	Uniquely identifies the frame of reference for a Series.
Image Comments	(0020,4000)	-	3	User-defined comments about the image.
Quality Control Image	(0028,0300)	-	3	Indicates whether or not this image is a quality control or phantom image. If this Attribute is absent, then the image may or may not be a quality control or phantom image. Enumerated Values: YES, NO.
Burned In Annotation	(0028,0301)	-	3	Indicates whether or not image contains sufficient burned in annotation to identify the patient and date the image was acquired. If this Attribute is absent, then the image may or may not contain burned in annotation. Enumerated Values: YES, NO.
Lossy Image Compression	(0028,2110)	-	3	Specifies whether an Image has undergone lossy compression. Enumerated Values: 00 = Image has NOT been subjected to lossy compression, 01 = Image has been subjected to lossy compression.

Attribute Name	Tag	Private Creator	Type	Notes
Lossy Image CompressionRatio	(0028,2112)	-	3	Describes the approximate lossy compression ratio(s) that have been applied to this image. May be multi valued if successive lossy compression steps have been applied.
CSA Data Type	(0029,xx08)	SIEMENS CSA NON-IMAGE	1	CSA Data identification characteristics. Defined Terms: RAW DATA NUM 4 = NUMARIS/4 Raw Data SPEC NUM 4 = NUMARIS/4 Spectroscopy RAW DATA SOM 5 = Somaris/5 Raw Data RAW DATA SOM 7 = Somaris/5 Raw Data BSR REPORT = BSR Study Report Data COL REPORT SOM5 = syngo Colonography Report Data
CSA Data Version	(0029,xx09)	SIEMENS CSA NON-IMAGE	3	Version of CSA Data Info (0029,xx10) format and CSA Non-Image Data (7FE1,xx10) format.
CSA Data Info	(0029,xx10)	SIEMENS CSA NON-IMAGE	3	Information to describe the CSA Data (7FE1,xx10). The value of the attribute CSA Data Info (0029,xx10) can be build up in each user defined format.
CSA Data	(7FE1,xx10)	SIEMENS CSA NON-IMAGE	1	Binary data as byte stream.

CT Extensions of the Non-Image Object

Somaris/5 uses the following defined term for Image Type (0008,0008):

- Value 1: ORIGINAL
- Value 2: PRIMARY
- Value 3: AXIAL, LOCALIZER, OTHER
- Value 4: a CT_SOM5 * enumeration
- Value 5: Somaris/5 specific enumeration

The following table lists the Somaris/5 non-image types and the corresponding combinations of the Image Type Attribute values.

Description	0008,0008 Value 1	0008,0008 Value 2	0008,0008 Value 3	0008,0008 Value 4	0008,0008 Value 5
CAD Results	DERIVED	SECONDARY	OTHER	CAD MARKS	none
Colonography Data	DERIVED	SECONDARY	OTHER	CT_SOM5 COL	none
Coronary Tree	DERIVED	SECONDARY	OTHER	CT_CIRCULATION	none
Raw Data	Same entries as for images				

Private SOP Classes

SOP Class Name	SOP Class UID
CSA Non-Image	1.3.12.2.1107.5.9.1

Private Transfer Syntaxes

Not applicable.

AE Title / Presentation Address Mapping

To ensure unique identification the hostname should be part of the AE Titles (see examples below, hostname = station4). The string can be up to 16 characters long and must not contain any extended characters, only 7 bit ASCII characters (excluding control characters) are allowed according to DICOM standard. An example name is HRI_station4. Another common setting is the use of the hostname in capital letters, e.g. "STATION4".

Note

The current implementation does not support the full DICOM standard syntax. Spaces and special characters (like &<>") in the AE title string are not supported.

DICOM Verification

The Verification Service uses the AE configuration of the DICOM Service that is checked with the C-ECHO message. E.g. Verification will use the Storage AE, if initiated to check the configuration of a remote DICOM node.

DICOM Storage/StorageCommitment/QR AE Title

There is a common AE Title for Storage, Storage Commitment and Query/Retrieve. It can be configured via Service UI in Configuration/DICOM/General.

The port is set to the fixed value of 104.

DICOM Modality Worklist and MPPS AE Title

There is a common AE Title for Modality Worklist and MPPS. It can be configured via Service UI in Configuration/DICOM/General.

DICOM Print AE Title

There is a separate AE Title for Print application. It can be configured via Service UI in Configuration/DICOM/General.

No input of AETs starting with a numeric character is possible.

Remote AE Titles and Presentation Addresses

Remote AETs, host names, IP addresses and port numbers can be configured using the Service application. For each AET a list of supported services can be configured.

Configurable Parameters

Storage, Storage Commitment and Query/Retrieve

The Service Configuration Tool can be used to set the AETs, port numbers, host names, IP addresses and capabilities for the remote nodes' (SCP's). The user can select transfer syntaxes, compression types and query models for each SCP separately.

- If the C-STORE is initiated by a user, only the transfer syntax will be proposed that is configured via Options -> Transfer -> Network Nodes (No Compression, Lossless JPEG, Lossy JPEG). The default transfer syntax (ILE) will be proposed in any case.
- If the C-STORE is initiated by an autotransfer rule or by the C-MOVE SCP all transfer syntaxes that are configured in the Service UI for this particular network destination will be proposed. (Compressed Transfer Syntaxes will be proposed first followed by the uncompressed Transfer Syntaxes).

Additional configurable parameters for Storage Commitment are:

When acting as SCU:

- Flag to indicate whether the association will be kept open to receive the response or to close the association and be prepared to receive the response on another association.
- Time-out which defines how long the association of N-ACTION is kept to receive a N-EVENT-REPORT on the same association. The same value is used to wait for a N-EVENT-REPORT on another association (applicability of transaction UID).
(default 1 h)

When acting as SCP:

flag to indicate whether an archive system is installed.

Print

The Service application can be used to configure the SCP (DICOM Printer).

These parameters are mandatory to be set:

- AET
- Host name
- IP address
- Port number
- These parameters have defaults as per configuration file and can be changed:
 - Default camera
 - Pixel size
 - Additional or changed film sheet formats (e.g. inch 14x14, inch 14x17, ...)
 - List with mapping pixel size to each film sheet format
 - Minimal density
 - Stored printed film jobs
 - Media type
 - Film destination

Modality Worklist

The Service application can be used to set the AETs, port numbers, host names, IP addresses, capabilities, and time-outs for the remote nodes (SCPs).

Additional configurable parameters for Basic Worklist Query are:

- Query Waiting time - the time to wait for the C-FIND-RSP after sending the C-FIND-RQ (default 20 s)
- Max. Query Match Number - the maximum number of entries accepted in one worklist (default is 200)
- Query Interval - the time between two C-FIND-RQs to the Hospital Information System (default is 60 min)
- Broad Worklist Query behaviour: two values are defined:
 - Set the AE Title search attribute to the own AE Title, and the Modality search attribute to "*".
 - Set the Modality search attribute to the own modality and the AE Title search attribute to "*".

The sending of an empty Specific Character Set in a C-FIND-RQ can be omitted by configuration. However, this is not available in the Service application but must be set by a Siemens service technician.

Modality Performed Procedure Step

The Service application can be used to configure the Modality Worklist SCP to be a Modality Performed Procedure Step SCP also.

Additional configurable parameters for Modality Performed Procedure Step are:

- Default Catalog Name - (0008,0102) used for items entered in MPPS UI
- Default Catalog Version - (0008,0103) used for items entered in MPPS UI

Default Parameters

This configuration tool also uses some default parameters:

- maximal PDU size set to 262144 Bytes
- time-out for accepting/rejecting an association request: 60 s
- time-out for responding to an association open/close request: 60 s
- time-out for accepting a message over network: 60 s
- time-out for waiting for data between TCP/IP-packets: 60 s

The Time-outs for waiting for a Request/Response message from the remote node are as follows:

- for Storage SCP/SCU: 600 s
- for Storage Commitment SCU:
 - time-out for Response to N-ACTION: 600 s
 - time-out for N-EVENT-REPORT: configurable, see → page A.5–3, *Configurable Parameters*.
- for Query/Retrieve SCP/SCU: 600 s
- for Modality Worklist SCU: configurable, see → page A.5–3, *Configurable Parameters*.
- for Print Management SCU:
 - time-out for Response to N-SET-RQ: 240 s
 - time-out for Response to other Requests: 60 s

The Somaris/5 DICOM application supports the following character sets as defined in the three tables below:

Single-Byte Character Sets without Code Extension

Character Set Description	Defined Term	ISO registration number	Character Set
Default repertoire	none	ISO_IR 6	ISO 646:
Latin alphabet No. 1	ISO_IR 100	ISO_IR 100	Supplementary set
		ISO_IR 6	ISO 646:
Latin alphabet No. 2	ISO_IR 101	ISO_IR 101	Supplementary set
		ISO_IR 6	ISO 646
Latin alphabet No. 3	ISO_IR 109	ISO_IR 109	Supplementary set
		ISO_IR 6	ISO 646
Latin alphabet No. 4	ISO_IR 110	ISO_IR 110	Supplementary set
		ISO_IR 6	ISO 646
Cyrillic	ISO_IR 144	ISO_IR 144	Supplementary set
		ISO_IR 6	ISO 646
Arabic	ISO_IR 127	ISO_IR 127	Supplementary set
		ISO_IR 6	ISO 646
Greek	ISO_IR 126	ISO_IR 126	Supplementary set
		ISO_IR 6	ISO 646
Hebrew	ISO_IR 138	ISO_IR 138	Supplementary set
		ISO_IR 6	ISO 646
Latin alphabet No. 5	ISO_IR 148	ISO_IR 148	Supplementary set
		ISO_IR 6	ISO 646

Single-Byte Character Sets without Code Extension

Character Set Description	Defined Term	ISO registration number	Character Set
Japanese	ISO_IR 13	ISO_IR 13	JIS X 0201: Katakana
		ISO_IR 14	JIS X 0201: Romaji

Single-Byte Character Sets with Code Extension

Character Set Description	Defined Term	Standard for Code Extension	ESC sequence	ISO registration number	Character Set
Default repertoire	ISO 2022 IR 6	ISO 2022	ESC 02/08 04/02	ISO-IR 6	ISO 646
Latin alphabet No.1	ISO 2022 IR 100	ISO 2022	ESC 02/13 04/01	ISO-IR 100	Supplementary set
		ISO 2022	ESC 02/08 04/02	ISO-IR 6	ISO 646
Latin alphabet No.2	ISO 2022 IR 101	ISO 2022	ESC 02/13 04/02	ISO-IR 101	Supplementary set
		ISO 2022	ESC 02/08 04/02	ISO-IR 6	ISO 646
Latin alphabet No.3	ISO 2022 IR 109	ISO 2022	ESC 02/13 04/03	ISO-IR 109	Supplementary set
		ISO 2022	ESC 02/08 04/02	ISO-IR 6	ISO 646

Single-Byte Character Sets with Code Extension					
Character Set Description	Defined Term	Standard for Code Extension	ESC sequence	ISO registration number	Character Set
Latin alphabet No.4	ISO 2022 IR 110	ISO 2022	ESC 02/13 04/04	ISO-IR 110	Supplementary set
		ISO 2022	ESC 02/08 04/02	ISO-IR 6	ISO 646
Cyrillic	ISO 2022 IR 144	ISO 2022	ESC 02/13 04/12	ISO-IR 144	Supplementary set
		ISO 2022	ESC 02/08 04/02	ISO-IR 6	ISO 646
Arabic	ISO 2022 IR 127	ISO 2022	ESC 02/13 04/07	ISO-IR 127	Supplementary set
Greek	ISO 2022 IR 126	ISO 2022	ESC 02/13 04/06	ISO-IR 126	Supplementary set
		ISO 2022	ESC 02/08 04/02	ISO-IR 6	ISO 646
Hebrew	ISO 2022 IR 138	ISO 2022	ESC 02/13 04/08	ISO-IR 138	Supplementary set
		ISO 2022	ESC 02/13 04/02	ISO-IR 6	ISO 646
Latin alphabet No.5	ISO 2022 IR 148	ISO 2022	ESC 02/13 04/13	ISO-IR 148	Supplementary set
		ISO 2022	ESC 02/13 04/02	ISO-IR 6	ISO 646

Single-Byte Character Sets with Code Extension

Character Set Description	Defined Term	Standard for Code Extension	ESC sequence	ISO registration number	Character Set
Japanese	ISO 2022 IR 13	ISO 2022	ESC 02/13 04/09	ISO-IR 13	JIS X 0201: Katakana
		ISO 2022	ESC 02/13 04/10	ISO-IR 14	JIS X 0201-1976: Romaji

Multi-Byte Character Sets without Code Extension

Character Set Description	Defined Term	ISO registration number	Character Set
Unicode	ISO_IR 192	ISO 10646	Unicode in UTF-8
Chinese	GB18030	GB18030	GB 18030-2000 (China Association for Standardization)



Multi-Byte Character Sets with Code Extension					
Character Set Description	Defined Term	Standard for Code Extension	ESC sequence	ISO registration number	Character Set
Japanese	ISO 2022 IR 87	ISO 2022	ESC 02/04 04/02	ISO-IR 87	JIS X 0208: Kanji
	ISO 2022 IR 159	ISO 2022	ESC 02/04 02/08 04/04	ISO-IR 159	JIS X 0212: Supplementary Kanji set
Chinese ^a	ISO 2022 IR 58	ISO 2022	ESC 02/04 04/01	ISO-IR 58	GB2312-80 (China Association for Standardization)

a. This Character Set is an extension of DICOM for the Chinese language.

When there is a mismatch between the SCS tags (0008,0005) and the characters in an IOD received by the system, then the following measures are taken to make the characters DICOM conform:

- Try to import with ISO_IR 100. If ISO_IR 100 fails, convert each illegal character to a '?'.
- There are now three categories of character sets which have to be differentiated because of their different encoding formats:
 - Conventional ISO character sets: ISO_IR 6, ISO 2022 IR 6, ISO_IR 100, etc.
 - ➔ encoded in ISO 2022
 - ISO_IR 192 ➔ encoded in UTF-8
 - GB18030 ➔ encoded in GB18030

It is not possible to recognize the following mismatches automatically on receiving or importing:

- ❑ An attribute value is encoded in ISO_IR 192 \leftrightarrow (0008,0005) contains a conventional ISO character set as primary character set
- ❑ An attribute value is encoded in GB18030 \leftrightarrow (0008,0005) contains a conventional ISO character set as primary character set
- ❑ An attribute value is encoded in ISO 2022 \leftrightarrow (0008,0005) contains ISO_IR 192
- ❑ An attribute value is encoded in ISO 2022 \leftrightarrow (0008,0005) contains GB18030

An IOD that contains one of the above mentioned inconsistencies is not DICOM conform. As these kinds of inconsistencies cannot be recognized by the system, the IOD will not be rejected but the character data might be corrupted.

Older versions of syngo do not support the newly introduced character sets ISO_IR 192 and GB18030 and their special encodings. That means, an IOD which contains one of these new character sets in (0008,0005) will be rejected by an older syngo system.

DICOM *Conformance Statement*

Media Storage

This part contains the Conformance Statement to all "Offline Media Application Profiles (incl. private extensions)" supported by the Somaris/5 archive options.

The application profiles supported shall be:

- Standard Application Profiles
- Augmented Application Profiles
- syngo* private Application Profiles

For general introductory topics see → Page –5, *Introduction*.



Application Data Flow Diagram

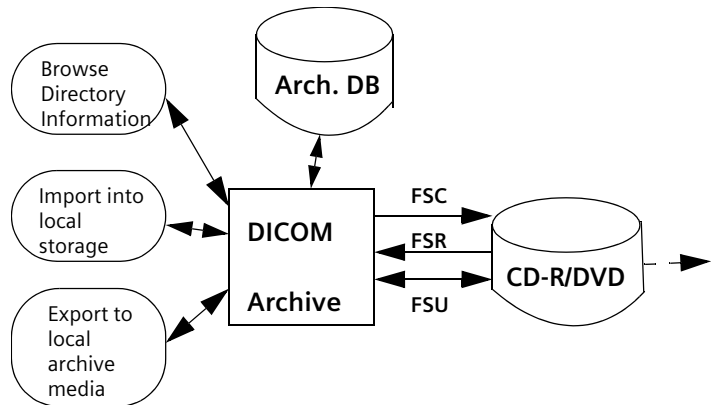

The DICOM archive application will serve as an interface to the CD-R/DVD off-line medium device. It serves interfaces to include the off-line media directory into the browser and to copy SOP instances to a medium or retrieve SOP Instances from medium into local storage.

The DICOM Archive application will support 120 mm CD-R and DVD-R (see Table → page B.2–1).

The FSU role will update new SOP Instances only to media with pre-existing File-sets conforming to the Application Profiles supported.

The contents of the DICOMDIR will be temporarily stored in Archive-Database.

Functional definitions of AE's

The Somaris/5 DICOM off-line media storage application consists of the DICOM Archive application entity serving all interfaces to access off-line media. The DICOM Archive application is capable of

- ✧ creating a new File-set onto an unwritten medium (Export to...)
- ✧ updating an existing File-set by writing new SOP Instances onto the medium
- ✧ importing SOP Instances from the medium onto local storage
- ✧ reading the File-set's DICOMDIR information temporarily into database and pass it to display applications.

Sequencing of Real-World Activities

The DICOM Archive application will not perform updates before the Directory information of the DICOMDIR is completely read.

When performing updates, the SOP instances are checked for existence before updating. Duplicate instances will be avoided.

File Meta Information Options

The Implementation Class UID is:

❑ "1.3.12.2.1107.5.1.4"

and an Implementation Version Name of

❑ "SIEMENS_S5VB41A"

DICOM Archive Specification

The DICOM Archive provides Standard conformance to Media Storage Service Class (Interchange Option).

Application Profiles Supported	Real World Activity	Role	SC Option
PRI-SYNGO-CD	Browse Directory Information	FSR	Interchange
PRI-SYNGO-DVD	Import into local Storage	FSR	Interchange
AUG-GEN-CD	Export to local archive media	FSC,FSU	Interchange
AUG-CTMR-CD ^a			
STD-XA1K-CD ^a			
STD-GEN-CD	Browse Directory Information	FSR	Interchange
STD-CTMR-CD	Import into local Storage	FSR	Interchange
STD-XABC-CD			
STD-XAIK-CD			
TD-US-zz-yF-xxxxxx ^b			

a. With no private SOP Class used, the PRI-SYNGO-CD profile definitions are appropriate to describe the augmentation of the related -STD Profiles.

b. All combinations of the following values for zz, yF and xxxxxx are supported:

'yF' can take two values: SF for Single Frame and MF for Multi Frame.

'zz' can take three values: ID (Image Display), SC (Spatial Calibration) and CC (Combined Calibration)

xxxxxx can take 2 values: CDR and DVD

On *syngo*-based products the Private Extended *syngo* Profile (e.g. PRI-SYNGO-CD) will be preferably used by the system. The General Purpose Interchange Profile (STD-GEN-CD), Ultrasound Profile (STD-US-xxx), CT and MR Image Profile (STD-CTMR-xxx), Waveform Interchange (STD-WVFM-xxx), Basic Cardiac Profile (STD-XABC-CD) and 1024 X-Ray Angiographic Profile (STD-XA1K-CD) will be supported with read capability of the related media.

File Meta Information for the Application Entity

The Source Application Entity Title is set by configuration. See → Chapter B.5, *Configuration* for details.

Real-World Activities for this Application Entity

Real-World Activity: Browse Directory Information

The DICOM Archive application acts as FSR using the interchange option when requested to read the media directory.

The DICOM archive application will read the DICOMDIR and insert that directory entries, that are valid for the application profiles supported, into a local database. The database can then be used for browsing media contents.

Note

Icon Image SQ is also supported in DICOMDIR. But only those Icon Images with Bits Allocated (0028,0100) equal to 8 and size 64 by 64 or 128 by 128 pixels are imported into database and are visible in PatientBrowser.

Application Profiles for the RWA: Browse Directory Information

See table → page B.2–1 for the Application Profiles listed that invoke this Application Entity for the Browse Directory Information RWA.

Real-World Activity: Import into local Storage

The DICOM Archive application acts as FSR using the interchange option when requested to read SOP Instances from the medium into the local storage.

The SOP Instance selected from the media directory will be copied into the local storage. Only SOP Instances, that are valid for the application profile supported and are listed as supported by the Storage SCP Conformance section (→ page A.2–4), can be retrieved from media storage. This is due to the fact that the Browse Directory Information will filter all SOP Instances not matching the Application profiles supported.

During operation no "Attribute Value Precedence" is applied to the SOP Instances. Detached Patient Management is not supported (please refer to DICOM part 11, Media Storage Application Profiles).

For media conforming to the STD-GEN-CD Profile the following SOP classes will be supported as a FSR:

Information Object Definitions	SOP Class UID	Transfer Syntax and UID
CR Image	1.2.840.10008.5.1.4.1.1.1	Explicit VR Little Endian Uncompressed 1.2.840.10008.1.2.1
DX Image - For Presentation	1.2.840.10008.5.1.4.1.1.1.1	Explicit VR Little Endian Uncompressed 1.2.840.10008.1.2.1
DX Image - For Processing	1.2.840.10008.5.1.4.1.1.1.1.1	Explicit VR Little Endian Uncompressed 1.2.840.10008.1.2.1
MG Image - For Presentation	1.2.840.10008.5.1.4.1.1.1.2	Explicit VR Little Endian Uncompressed 1.2.840.10008.1.2.1
MG Image - For Processing	1.2.840.10008.5.1.4.1.1.1.2.1	Explicit VR Little Endian Uncompressed 1.2.840.10008.1.2.1



Information Object Definitions	SOP Class UID	Transfer Syntax and UID
IOX Image - For Presentation	1.2.840.10008.5.1.4.1.1.1.3	Explicit VR Little Endian Uncompressed 1.2.840.10008.1.2.1
IOX Image - For Processing	1.2.840.10008.5.1.4.1.1.1.3.1	Explicit VR Little Endian Uncompressed 1.2.840.10008.1.2.1
CT Image	1.2.840.10008.5.1.4.1.1.2	Explicit VR Little Endian Uncompressed 1.2.840.10008.1.2.1
US-MF image (retired)	1.2.840.10008.5.1.4.1.1.3	Explicit VR Little Endian Uncompressed 1.2.840.10008.1.2.1
US-MF image	1.2.840.10008.5.1.4.1.1.3.1	Explicit VR Little Endian Uncompressed 1.2.840.10008.1.2.1
MR Image	1.2.840.10008.5.1.4.1.1.4	Explicit VR Little Endian Uncompressed 1.2.840.10008.1.2.1
US Image (retired)	1.2.840.10008.5.1.4.1.1.6	Explicit VR Little Endian Uncompressed 1.2.840.10008.1.2.1
US Image	1.2.840.10008.5.1.4.1.1.6.1	Explicit VR Little Endian Uncompressed 1.2.840.10008.1.2.1
SC Image	1.2.840.10008.5.1.4.1.1.7	Explicit VR Little Endian Uncompressed 1.2.840.10008.1.2.1
12-lead ECG Waveform Storage	1.2.840.10008.5.1.4.1.1.9.1.1	Explicit VR Little Endian Uncompressed 1.2.840.10008.1.2.1

Information Object Definitions	SOP Class UID	Transfer Syntax and UID
General ECG Waveform Storage	1.2.840.10008.5.1.4.1.1.9.1.2	Explicit VR Little Endian Uncompressed 1.2.840.10008.1.2.1
Ambulatory ECG Wave-form Storage	1.2.840.10008.5.1.4.1.1.9.1.3	Explicit VR Little Endian Uncompressed 1.2.840.10008.1.2.1
Hemodynamic Waveform Storage	1.2.840.10008.5.1.4.1.1.9.2.1	Explicit VR Little Endian Uncompressed 1.2.840.10008.1.2.1
Cardiac Elec-trophysiology Waveform Storage	1.2.840.10008.5.1.4.1.1.9.3.1	Explicit VR Little Endian Uncompressed 1.2.840.10008.1.2.1
Basic Voice Audio Wave-form Storage	1.2.840.10008.5.1.4.1.1.9.4.1	Explicit VR Little Endian Uncompressed 1.2.840.10008.1.2.1
XA Image	1.2.840.10008.5.1.4.1.1.12.1	Explicit VR Little Endian Uncompressed 1.2.840.10008.1.2.1
XRF-Image	1.2.840.10008.5.1.4.1.1.12.2	Explicit VR Little Endian Uncompressed 1.2.840.10008.1.2.1
NM Image	1.2.840.10008.5.1.4.1.1.20	Explicit VR Little Endian Uncompressed 1.2.840.10008.1.2.1
Basic Text SR	1.2.840.10008.5.1.4.1.1.88.11	Explicit VR Little Endian Uncompressed 1.2.840.10008.1.2.1
Enhanced SR	1.2.840.10008.5.1.4.1.1.88.22	Explicit VR Little Endian Uncompressed 1.2.840.10008.1.2.1

Information Object Definitions	SOP Class UID	Transfer Syntax and UID
Comprehensive SR	1.2.840.10008.5.1.4.1.1.88.33	Explicit VR Little Endian Uncompressed 1.2.840.10008.1.2.1
Mammography CAD SR	1.2.840.10008.5.1.4.1.1.88.50	Explicit VR Little Endian Uncompressed 1.2.840.10008.1.2.1
Chest CAD SR	1.2.840.10008.5.1.4.1.1.88.65	Explicit VR Little Endian Uncompressed 1.2.840.10008.1.2.1
X-Ray Radiation Dose SR	1.2.840.10008.5.1.4.1.1.88.67	Explicit VR Little Endian Uncompressed 1.2.840.10008.1.2.1
PET Image	1.2.840.10008.5.1.4.1.1.128	Explicit VR Little Endian Uncompressed 1.2.840.10008.1.2.1
RT Image	1.2.840.10008.5.1.4.1.1.481.1	Explicit VR Little Endian Uncompressed 1.2.840.10008.1.2.1
RT Dose	1.2.840.10008.5.1.4.1.1.481.2	Explicit VR Little Endian Uncompressed 1.2.840.10008.1.2.1
RT Structure Set	1.2.840.10008.5.1.4.1.1.481.3	Explicit VR Little Endian Uncompressed 1.2.840.10008.1.2.1
RT Plan	1.2.840.10008.5.1.4.1.1.481.5	Explicit VR Little Endian Uncompressed 1.2.840.10008.1.2.1
RT Brachy Treatment Record	1.2.840.10008.5.1.4.1.1.481.6	Explicit VR Little Endian Uncompressed 1.2.840.10008.1.2.1



Information Object Definitions	SOP Class UID	Transfer Syntax and UID
RT Treatment Summary Record	1.2.840.10008.5.1.4.1.1.481.7	Explicit VR Little Endian Uncompressed 1.2.840.10008.1.2.1
RT Ion Plan	1.2.840.10008.5.1.4.1.1.481.8	Explicit VR Little Endian Uncompressed 1.2.840.10008.1.2.1
RT Ion Beams Treatment Record	1.2.840.10008.5.1.4.1.1.481.9	Explicit VR Little Endian Uncompressed 1.2.840.10008.1.2.1
Csa Non-Image	1.3.12.2.1107.5.9.1	Explicit VR Little Endian Uncompressed 1.2.840.10008.1.2.1

Application Profiles for the RWA: Import into local Storage

See table → page B.2–1 for the Application Profiles listed that invoke this Application Entity for the Copy to Local Storage RWA.

Real-World Activity: Export to local Archive Media

The DICOM Archive application acts as FSU (for media with existing DICOM file-set) or FSC (media not initialized) using the interchange option when requested to copy SOP Instances from the local storage to local Archive medium.

The DICOM Archive application will receive a list of SOP Instances to be copied to the local archive medium. According to the state of the medium inserted (new medium, Medium with DICOM file-set) the validity of the SOP Instances according to the applicable profile is checked. Only valid SOP Instances are accepted.

When the DICOM archive application is requested to copy SOP Instances the preferred application profile according configuration will be used to validate and copy the referred SOP Instances. When creating a new file set no Descriptor File will be allocated and the related ID is not used.

The DICOM archive application will not close the medium.

Application Profiles for the RWA: Export to local Archive Media

See table → page B.2–1 for the Application Profiles listed that invoke this Application Entity for the Export to local Archive Media RWA.

Augmented Application Profiles

AUG-GEN-CD

With no private Siemens Non-Images stored onto Medium, the definitions of the PRI-SYNGO-CD Profile are applicable to denote the augmentations for the STD-GEN-CD Standard Profile.

Storage of Private Information Objects will only be supported with reference to a Private Application Profile (see next section).

The Siemens non-image is typically used for raw data and 3D private data.

AUG-CTMR-xxxx

With no private Siemens Non-Images stored onto Medium, the definitions of the PRI-SYNGO-CD Profile are applicable to denote the augmentations for the and STD-CTMR-CD Standard Profiles.

Storage of Private Information Objects will only be supported with reference to a Private Application Profile (see next section).

AUG-XA1K-CD

With no private Siemens Non-Images stored onto Medium, the definitions of the PRI-SYNGO-CD Profile are applicable to denote the augmentations for the STD-XA1K-CD Standard Profile.

Storage of Private Information Objects will only be supported with reference to a Private Application Profile (see next section).



syngo[®] private offline Media Application Profiles

This section will contain a syngo specific Application Profile.

The Structure of this Application Profile is defined in Part 11 of the 2000 DICOM Standard.

It is needed to describe the requirements for Offline Media Storage of the private IOD (Non-Image IOD).

Class and Profile Identification

This document defines an Application Profile class for "syngo[®] speaking¹" modalities or applications.

The identifier for this class shall be PRI-SYNGO. This class is intended to be used for interchange of extended and private Information Objects via CD-R offline media between dedicated acquisition or workstation modalities built from a common *syngo* architecture.

1. 'syngo' and 'We speak syngo' are registered trademarks of Siemens AG

The specific application profiles in this class are shown in the table below:

Application Profile	Identifier	Description
"syngo speaking" System on CD-R	PRI-SYNGO-CD	Handles interchange of Composite SOP Instances and privately defined SOP Instances (Siemens Non-Image IOD)
"syngo speaking" System on DVD R	PRI-SYNGO-DVD	Handles interchange of Composite SOP Instances and privately defined SOP Instances (Siemens Non-Image IOD)

Equipment claiming conformance for this *syngo* Application Profile Class shall make a clear statement on handling of the private defined SOP Instances.

Clinical Context

This application profile facilitates the interchange of original acquired and derived images and private data related to them. Typical media interchange would be from in-lab acquisition equipment to dedicated workstations and archive systems with specific extensions to handle the private data objects (in both directions).

Additionally, images used to prepare procedures, multi-modality images (e.g. integrated US) and images derived from primary diagnostic images, such as annotations, quantitative analysis images, reference images, screen capture images may be interchanged via this profile.

Roles and Service Class Options

This Application Profile uses the Media Storage Service Class defines in PS 3.4 with the Interchange Option.

The Application Entity shall support one or more of the roles of File Set Creator (FSC), File Set Reader (FSR), and File Set Updater (FSU), defined in PS3.10.

File Set Creator

The Application Entity acting as File Set Creator generates a File Set under the PRI-SYNGO Application Profiles.

File Set Creators shall be able to generate the Basic Directory SOP Class in the DICOMDIR file with all the subsidiary Directory Records related to the Image SOP Classes and Private SOP Classes stored in the File Set.

In case of the PRI-SYNGO-CD and PRI-SYNGO-DVD profile, the FSC shall offer the ability to allow multi-session (additional information may be subsequently added to the disc). For both profiles a multi-session media can be finalized.

Note

A multiple volume (a logical volume that can cross multiple physical media) is not supported by this Application Profile Class. If a set of Files, e.g., a Study, cannot be written entirely on one CD-R, the FSC will create multiple independent DICOM File Sets such that each File Set can reside on a single CD-R medium controlled by its individual DICOMDIR file. The user of the FSC can opt to use written labels on the discs to reflect that there is more than one disc for this set of files (e.g. a study).

File Set Reader

The role of the File Set Reader shall be used by Application Entities which receive the transferred File Set.

File Set Readers shall be able to read all the defined SOP Instances files defined for the specific Application Profiles to which a conformance claim is made, using all the defined Transfer Syntaxes.

File Set Updater

The role of the File Set Updater shall be used by Application Entities, which receive a transferred File Set and update it by the addition of processed information.

File Set Updaters shall be able to read and update the DICOMDIR file. File Set Updaters do not have to read the image/private information objects. File Set Updaters shall be able to generate any of the SOP Instance files defined for the specific Application Profiles to which a conformance claim is made, and to read and update the DICOMDIR file.

In case of the PRI-SYNGO-CD and PRI-SYNGO-DVD profile, the FSU shall offer the ability to allow multi-session (additional information can be subsequently added to the disc).

Note (for CD-R and DVD-R)

If the disc has not been finalized, the File Set Updater will be able to update information assuming there is enough space on the disc to write a new DICOMDIR file, the information, and the fundamental CD-R/DVD-R control structures. CD-R/DVD-R control structures are the structures that inherent to CD-R standards; see PS 3.12

PRI-SYNGO Profiles

SOP Classes and Transfer Syntaxes

These Application Profiles are based on the Media Storage Service Class with the Interchange Option. In the table below Transfer Syntax UID "RLE Lossless" applies only for decompression.

Information Object Definitions	SOP Class UID	Transfer Syntax and UID	FSC	FSR	FSU
Basic Directory	1.2.840.10008.1.3.10	Explicit VR Little Endian Uncompressed 1.2.840.10008.1.2.1	M	M	M
CR Image	1.2.840.10008.5.1.4.1.1.1	Explicit VR Little Endian Uncompressed 1.2.840.10008.1.2.1	M	M	O
CR Image	1.2.840.10008.5.1.4.1.1.1	JPEG Lossless Process 14 (selection value 1) 1.2.840.10008.1.2.4.70	O	M	O
CR Image	1.2.840.10008.5.1.4.1.1.1	Explicit VR Big Endian Uncompressed 1.2.840.10008.1.2.2	O	M	O
CR Image	1.2.840.10008.5.1.4.1.1.1	JPEG Lossy (baseline or extended) 1.2.840.10008.1.2.4.50 1.2.840.10008.1.2.4.51	O	O	O
CR Image	1.2.840.10008.5.1.4.1.1.1	RLE Lossless 1.2.840.10008.1.2.5	O	O	O
CR Image	1.2.840.10008.5.1.4.1.1.1	JPEG 2000 Lossless 1.2.840.10008.1.2.90	O	O	O
CR Image	1.2.840.10008.5.1.4.1.1.1	JPEG 2000 Lossy 1.2.840.10008.1.2.91	M	M	O
DX Image - For Presentation	1.2.840.10008.5.1.4.1.1.1.1	Explicit VR Little Endian Uncompressed 1.2.840.10008.1.2.1	M	M	O

Information Object Definitions	SOP Class UID	Transfer Syntax and UID	FSC	FSR	FSU
DX Image - For Presentation	1.2.840.10008.5.1.4.1.1.1.1	JPEG Lossless Process 14 (selection value 1) 1.2.840.10008.1.2.4.70	O	M	O
DX Image - For Presentation	1.2.840.10008.5.1.4.1.1.1.1	Explicit VR Big Endian Uncompressed 1.2.840.10008.1.2.2	O	M	O
DX Image - For Presentation	1.2.840.10008.5.1.4.1.1.1.1	JPEG Lossy (baseline or extended) 1.2.840.10008.1.2.4.50 1.2.840.10008.1.2.4.51	O	O	O
DX Image - For Presentation	1.2.840.10008.5.1.4.1.1.1.1	RLE Lossless 1.2.840.10008.1.2.5	O	O	O
DX Image - For Presentation	1.2.840.10008.5.1.4.1.1.1.1	JPEG 2000 Lossless 1.2.840.10008.1.2.90	O	O	O
DX Image - For Presentation	1.2.840.10008.5.1.4.1.1.1.1	JPEG 2000 Lossy 1.2.840.10008.1.2.91	O	O	O
DX Image - For Processing	1.2.840.10008.5.1.4.1.1.1.1.1	Explicit VR Little Endian Uncompressed 1.2.840.10008.1.2.1	M	M	O
DX Image - For Processing	1.2.840.10008.5.1.4.1.1.1.1.1	JPEG Lossless Process 14 (selection value 1) 1.2.840.10008.1.2.4.70	O	M	O
DX Image - For Processing	1.2.840.10008.5.1.4.1.1.1.1.1	Explicit VR Big Endian Uncompressed 1.2.840.10008.1.2.2	O	M	O
DX Image - For Processing	1.2.840.10008.5.1.4.1.1.1.1.1	JPEG Lossy (baseline or extended) 1.2.840.10008.1.2.4.50 1.2.840.10008.1.2.4.51	O	O	O
DX Image - For Processing	1.2.840.10008.5.1.4.1.1.1.1.1	RLE Lossless 1.2.840.10008.1.2.5	O	O	O
MG Image - For Presentation	1.2.840.10008.5.1.4.1.1.1.2	Explicit VR Little Endian Uncompressed 1.2.840.10008.1.2.1	M	M	O



Information Object Definitions	SOP Class UID	Transfer Syntax and UID	FSC	FSR	FSU
MG Image - For Presentation	1.2.840.10008.5.1.4.1.1.1.2	JPEG Lossless Process 14 (selection value 1) 1.2.840.10008.1.2.4.70	O	M	O
MG Image - For Presentation	1.2.840.10008.5.1.4.1.1.1.2	Explicit VR Big Endian Uncompressed 1.2.840.10008.1.2.2	O	M	O
MG Image - For Presentation	1.2.840.10008.5.1.4.1.1.1.2	JPEG Lossy (baseline or extended) 1.2.840.10008.1.2.4.50 1.2.840.10008.1.2.4.51	O	O	O
MG Image - For Presentation	1.2.840.10008.5.1.4.1.1.1.2	JPEG Lossless 1.2.840.10008.1.2.90	O	O	O
MG Image - For Presentation	1.2.840.10008.5.1.4.1.1.1.2	JPEG Lossy 1.2.840.10008.1.2.91	O	O	O
MG Image - For Presentation	1.2.840.10008.5.1.4.1.1.1.2	RLE Lossless 1.2.840.10008.1.2.5	O	O	O
MG Image - For Processing	1.2.840.10008.5.1.4.1.1.1.2.1	Explicit VR Little Endian Uncompressed 1.2.840.10008.1.2.1	M	M	O
MG Image - For Processing	1.2.840.10008.5.1.4.1.1.1.2.1	JPEG Lossless Process 14 (selection value 1) 1.2.840.10008.1.2.4.70	O	M	O
MG Image - For Processing	1.2.840.10008.5.1.4.1.1.1.2.1	Explicit VR Big Endian Uncompressed 1.2.840.10008.1.2.2	O	M	O
MG Image - For Processing	1.2.840.10008.5.1.4.1.1.1.2.1	JPEG Lossy (baseline or extended) 1.2.840.10008.1.2.4.50 1.2.840.10008.1.2.4.51	O	O	O
MG Image - For Processing	1.2.840.10008.5.1.4.1.1.1.2.1	RLE Lossless 1.2.840.10008.1.2.5	O	O	O
IOX Image - For Presentation	1.2.840.10008.5.1.4.1.1.1.3	Explicit VR Little Endian Uncompressed 1.2.840.10008.1.2.1	M	M	O

Information Object Definitions	SOP Class UID	Transfer Syntax and UID	FSC	FSR	FSU
IOX Image - For Presentation	1.2.840.10008.5.1.4.1.1.1.3	JPEG Lossless Process 14 (selection value 1) 1.2.840.10008.1.2.4.70	O	M	O
IOX Image - For Presentation	1.2.840.10008.5.1.4.1.1.1.3	Explicit VR Big Endian Uncompressed 1.2.840.10008.1.2.2	O	M	O
IOX Image - For Presentation	1.2.840.10008.5.1.4.1.1.1.3	JPEG Lossy (baseline or extended) 1.2.840.10008.1.2.4.50 1.2.840.10008.1.2.4.51	O	O	O
IOX Image - For Presentation	1.2.840.10008.5.1.4.1.1.1.3	RLE Lossless 1.2.840.10008.1.2.5	O	O	O
IOX Image - For Presentation	1.2.840.10008.5.1.4.1.1.1.3	JPEG Lossless 1.2.840.10008.1.2.90	O	O	O
IOX Image - For Presentation	1.2.840.10008.5.1.4.1.1.1.3	JPEG Lossy 1.2.840.10008.1.2.91	O	O	O
IOX Image - For Processing	1.2.840.10008.5.1.4.1.1.1.3.1	Explicit VR Little Endian Uncompressed 1.2.840.10008.1.2.1	M	M	O
IOX Image - For Processing	1.2.840.10008.5.1.4.1.1.1.3.1	JPEG Lossless Process 14 (selection value 1) 1.2.840.10008.1.2.4.70	O	M	O
IOX Image - For Processing	1.2.840.10008.5.1.4.1.1.1.3.1	Explicit VR Big Endian Uncompressed 1.2.840.10008.1.2.2	O	M	O
IOX Image - For Processing	1.2.840.10008.5.1.4.1.1.1.3.1	JPEG Lossy (baseline or extended) 1.2.840.10008.1.2.4.50 1.2.840.10008.1.2.4.51	O	O	O
IOX Image - For Processing	1.2.840.10008.5.1.4.1.1.1.3.1	RLE Lossless 1.2.840.10008.1.2.5	O	O	O
CT Image	1.2.840.10008.5.1.4.1.1.2	Explicit VR Little Endian Uncompressed 1.2.840.10008.1.2.1	M	M	O



Information Object Definitions	SOP Class UID	Transfer Syntax and UID	FSC	FSR	FSU
CT Image	1.2.840.10008.5.1.4.1.1.2	JPEG Lossless Process 14 (selection value 1) 1.2.840.10008.1.2.4.70	O	M	O
CT Image	1.2.840.10008.5.1.4.1.1.2	Explicit VR Big Endian Uncompressed 1.2.840.10008.1.2.2	O	M	O
CT Image	1.2.840.10008.5.1.4.1.1.2	JPEG Lossy (baseline or extended) 1.2.840.10008.1.2.4.50 1.2.840.10008.1.2.4.51	O	O	O
CT Image	1.2.840.10008.5.1.4.1.1.2	RLE Lossless 1.2.840.10008.1.2.5	O	O	O
CT Image	1.2.840.10008.5.1.4.1.1.2	JPEG 2000 Lossless 1.2.840.10008.1.2.90	O	O	O
CT Image	1.2.840.10008.5.1.4.1.1.2	JPEG 2000 Lossy 1.2.840.10008.1.2.91	O	O	O
US-MF image (retired)	1.2.840.10008.5.1.4.1.1.3	Explicit VR Little Endian Uncompressed 1.2.840.10008.1.2.1	-	M	-
US-MF image (retired)	1.2.840.10008.5.1.4.1.1.3	JPEG Lossless Process 14 (selection value 1) 1.2.840.10008.1.2.4.70	-	M	-
US-MF image (retired)	1.2.840.10008.5.1.4.1.1.3	Explicit VR Big Endian Uncompressed 1.2.840.10008.1.2.2	-	M	-
US-MF image (retired)	1.2.840.10008.5.1.4.1.1.3	JPEG Lossy (baseline or extended) 1.2.840.10008.1.2.4.50 1.2.840.10008.1.2.4.51	-	M	-
US-MF image (retired)	1.2.840.10008.5.1.4.1.1.3	RLE Lossless 1.2.840.10008.1.2.5	-	M	-
US-MF image (retired)	1.2.840.10008.5.1.4.1.1.3	JPEG 2000 Lossless 1.2.840.10008.1.2.90	-	M	-

Information Object Definitions	SOP Class UID	Transfer Syntax and UID	FSC	FSR	FSU
US-MF image (retired)	1.2.840.10008.5.1.4.1.1.3	JPEG 2000 Lossy 1.2.840.10008.1.2.91	-	M	-
US-MF image	1.2.840.10008.5.1.4.1.1.3.1	Explicit VR Little Endian Uncompressed 1.2.840.10008.1.2.1	M	M	O
US-MF image	1.2.840.10008.5.1.4.1.1.3.1	JPEG Lossless Process 14 (selection value 1) 1.2.840.10008.1.2.4.70	O	M	O
US-MF image	1.2.840.10008.5.1.4.1.1.3.1	Explicit VR Big Endian Uncompressed 1.2.840.10008.1.2.2	O	M	O
US-MF image	1.2.840.10008.5.1.4.1.1.3.1	JPEG Lossy (baseline or extended) 1.2.840.10008.1.2.4.50 1.2.840.10008.1.2.4.51	O	O	O
US-MF image	1.2.840.10008.5.1.4.1.1.3.1	RLE Lossless 1.2.840.10008.1.2.5	O	M	O
MR Image	1.2.840.10008.5.1.4.1.1.4	Explicit VR Little Endian Uncompressed 1.2.840.10008.1.2.1	M	M	O
MR Image	1.2.840.10008.5.1.4.1.1.4	JPEG Lossless Process 14 (selection value 1) 1.2.840.10008.1.2.4.70	O	M	O
MR Image	1.2.840.10008.5.1.4.1.1.4	Explicit VR Big Endian Uncompressed 1.2.840.10008.1.2.2	O	M	O
MR Image	1.2.840.10008.5.1.4.1.1.4	JPEG Lossy (baseline or extended) 1.2.840.10008.1.2.4.50 1.2.840.10008.1.2.4.51	O	O	O
MR Image	1.2.840.10008.5.1.4.1.1.4	RLE Lossless 1.2.840.10008.1.2.5	O	O	O

Information Object Definitions	SOP Class UID	Transfer Syntax and UID	FSC	FSR	FSU
MR Image	1.2.840.10008.5.1.4.1.1.4	JPEG 2000 Lossless 1.2.840.10008.1.2.90	O	O	O
MR Image	1.2.840.10008.5.1.4.1.1.4	JPEG 2000 Lossy 1.2.840.10008.1.2.91	O	O	O
US Image (retired)	1.2.840.10008.5.1.4.1.1.6	Explicit VR Little Endian Uncompressed 1.2.840.10008.1.2.1	-	M	-
US Image (retired)	1.2.840.10008.5.1.4.1.1.6	JPEG Lossless Process 14 (selection value 1) 1.2.840.10008.1.2.4.70	-	M	-
US Image (retired)	1.2.840.10008.5.1.4.1.1.6	Explicit VR Big Endian Uncompressed 1.2.840.10008.1.2.2	-	M	-
US Image (retired)	1.2.840.10008.5.1.4.1.1.6	JPEG Lossy (baseline or extended) 1.2.840.10008.1.2.4.50 1.2.840.10008.1.2.4.51	-	M	-
US Image (retired)	1.2.840.10008.5.1.4.1.1.6	RLE Lossless 1.2.840.10008.1.2.5	-	M	-
US Image (retired)	1.2.840.10008.5.1.4.1.1.6	JPEG 2000 Lossless 1.2.840.10008.1.2.90	-	M	-
US Image (retired)	1.2.840.10008.5.1.4.1.1.6	JPEG 2000 Lossy 1.2.840.10008.1.2.91	-	O	-
US Image	1.2.840.10008.5.1.4.1.1.6.1	Explicit VR Little Endian Uncompressed 1.2.840.10008.1.2.1	M	M	O
US Image	1.2.840.10008.5.1.4.1.1.6.1	JPEG Lossless Process 14 (selection value 1) 1.2.840.10008.1.2.4.70	O	M	O
US Image	1.2.840.10008.5.1.4.1.1.6.1	Explicit VR Big Endian Uncompressed 1.2.840.10008.1.2.2	O	M	O

Information Object Definitions	SOP Class UID	Transfer Syntax and UID	FSC	FSR	FSU
US Image	1.2.840.10008.5.1.4.1.1.6.1	JPEG Lossy (baseline or extended) 1.2.840.10008.1.2.4.50 1.2.840.10008.1.2.4.51	O	O	O
US Image	1.2.840.10008.5.1.4.1.1.6.1	RLE Lossless 1.2.840.10008.1.2.5	O	M	O
US Image	1.2.840.10008.5.1.4.1.1.6.1	JPEG 2000 Lossless 1.2.840.10008.1.2.90	O	M	O
US Image	1.2.840.10008.5.1.4.1.1.6.1	JPEG 2000 Lossy 1.2.840.10008.1.2.91	O	M	O
SC Image	1.2.840.10008.5.1.4.1.1.7	Explicit VR Little Endian Uncompressed 1.2.840.10008.1.2.1	M	M	O
SC Image	1.2.840.10008.5.1.4.1.1.7	JPEG Lossless Process 14 (selection value 1) 1.2.840.10008.1.2.4.70	O	M	O
SC Image	1.2.840.10008.5.1.4.1.1.7	Explicit VR Big Endian Uncompressed 1.2.840.10008.1.2.2	O	M	O
SC Image	1.2.840.10008.5.1.4.1.1.7	JPEG Lossy (baseline or extended) 1.2.840.10008.1.2.4.50 1.2.840.10008.1.2.4.51	O	O	O
SC Image	1.2.840.10008.5.1.4.1.1.7	RLE Lossless 1.2.840.10008.1.2.5	O	O	O
SC Image	1.2.840.10008.5.1.4.1.1.7	JPEG 2000 Lossless 1.2.840.10008.1.2.90	O	O	O
SC Image	1.2.840.10008.5.1.4.1.1.7	JPEG 2000 Lossy 1.2.840.10008.1.2.91	O	O	O



Information Object Definitions	SOP Class UID	Transfer Syntax and UID	FSC	FSR	FSU
Waveform Storage SOP Classes	1.2.840.10008.5.1.4.1.1.9.1.1 1.2.840.10008.5.1.4.1.1.9.1.2 1.2.840.10008.5.1.4.1.1.9.1.3 1.2.840.10008.5.1.4.1.1.9.2.1 1.2.840.10008.5.1.4.1.1.9.3.1 1.2.840.10008.5.1.4.1.1.9.4.1	Explicit VR Little Endian Uncompressed 1.2.840.10008.1.2.1	M	M	O
Waveform Storage SOP Classes	1.2.840.10008.5.1.4.1.1.9.1.1 1.2.840.10008.5.1.4.1.1.9.1.2 1.2.840.10008.5.1.4.1.1.9.1.3 1.2.840.10008.5.1.4.1.1.9.2.1 1.2.840.10008.5.1.4.1.1.9.3.1 1.2.840.10008.5.1.4.1.1.9.4.1	Explicit VR Big Endian Uncompressed 1.2.840.10008.1.2.1	O	M	O
X-Ray Angiographic Image	1.2.840.10008.5.1.4.1.1.12.1	Explicit VR Little Endian Uncompressed 1.2.840.10008.1.2.1	M	M	O
X-Ray Angiographic Image	1.2.840.10008.5.1.4.1.1.12.1	JPEG Lossless Process 14 (selection value 1) 1.2.840.10008.1.2.4.70	O	M	O
X-Ray Angiographic Image	1.2.840.10008.5.1.4.1.1.12.1	Explicit VR Big Endian Uncompressed 1.2.840.10008.1.2.2	O	M	O
X-Ray Angiographic Image	1.2.840.10008.5.1.4.1.1.12.1	JPEG Lossy (baseline or extended) 1.2.840.10008.1.2.4.50 1.2.840.10008.1.2.4.51	O	O	O
X-Ray Angiographic Image	1.2.840.10008.5.1.4.1.1.12.1	RLE Lossless 1.2.840.10008.1.2.5	O	M	O
X-Ray Angiographic Image	1.2.840.10008.5.1.4.1.1.12.1	JPEG 2000 Lossless 1.2.840.10008.1.2.90	O	M	O
X-Ray Angiographic Image	1.2.840.10008.5.1.4.1.1.12.1	JPEG 2000 Lossy 1.2.840.10008.1.2.91	O	M	O

Information Object Definitions	SOP Class UID	Transfer Syntax and UID	FSC	FSR	FSU
X-Ray Radio-fluoroscopic Image	1.2.840.10008.5.1.4.1.1.12.2	Explicit VR Little Endian Uncompressed 1.2.840.10008.1.2.1	M	M	O
X-Ray Radio-fluoroscopic Image	1.2.840.10008.5.1.4.1.1.12.2	JPEG Lossless Process 14 (selection value 1) 1.2.840.10008.1.2.4.70	O	M	O
X-Ray Radio-fluoroscopic Image	1.2.840.10008.5.1.4.1.1.12.2	Explicit VR Big Endian Uncompressed 1.2.840.10008.1.2.2	O	M	O
X-Ray Radio-fluoroscopic Image	1.2.840.10008.5.1.4.1.1.12.2	JPEG Lossy (baseline or extended) 1.2.840.10008.1.2.4.50 1.2.840.10008.1.2.4.51	O	O	O
X-Ray Radio-fluoroscopic Image	1.2.840.10008.5.1.4.1.1.12.2	RLE Lossless 1.2.840.10008.1.2.5	O	M	O
X-Ray Radio-fluoroscopic Image	1.2.840.10008.5.1.4.1.1.12.2	JPEG 2000 Lossless 1.2.840.10008.1.2.90	O	M	O
X-Ray Radio-fluoroscopic Image	1.2.840.10008.5.1.4.1.1.12.2	JPEG 2000 Lossy 1.2.840.10008.1.2.91	O	M	O
NM Image	1.2.840.10008.5.1.4.1.1.20	Explicit VR Little Endian Uncompressed 1.2.840.10008.1.2.1	M	M	O
NM Image	1.2.840.10008.5.1.4.1.1.20	JPEG Lossless Process 14 (selection value 1) 1.2.840.10008.1.2.4.70	O	M	O
NM Image	1.2.840.10008.5.1.4.1.1.20	Explicit VR Big Endian Uncompressed 1.2.840.10008.1.2.2	O	M	O



Information Object Definitions	SOP Class UID	Transfer Syntax and UID	FSC	FSR	FSU
NM Image	1.2.840.10008.5.1.4.1.1.20	JPEG Lossy (baseline or extended) 1.2.840.10008.1.2.4.50 1.2.840.10008.1.2.4.51	O	O	O
NM Image	1.2.840.10008.5.1.4.1.1.20	RLE Lossless 1.2.840.10008.1.2.5	O	O	O
NM Image	1.2.840.10008.5.1.4.1.1.20	JPEG 2000 Lossless 1.2.840.10008.1.2.90	O	O	O
NM Image	1.2.840.10008.5.1.4.1.1.20	JPEG 2000 Lossy 1.2.840.10008.1.2.91	O	O	O
Basic Text SR	1.2.840.10008.5.1.4.1.1.88.11	Explicit VR Little Endian Uncompressed 1.2.840.10008.1.2.1	M	M	O
Basic Text SR	1.2.840.10008.5.1.4.1.1.88.11	Explicit VR Big Endian Uncompressed 1.2.840.10008.1.2.2	O	M	O
Enhanced SR	1.2.840.10008.5.1.4.1.1.88.22	Explicit VR Little Endian Uncompressed 1.2.840.10008.1.2.1	M	M	O
Enhanced SR	1.2.840.10008.5.1.4.1.1.88.22	Explicit VR Big Endian Uncompressed 1.2.840.10008.1.2.2	O	M	O
Comprehensive SR	1.2.840.10008.5.1.4.1.1.88.33	Explicit VR Little Endian Uncompressed 1.2.840.10008.1.2.1	M	M	O
Comprehensive SR	1.2.840.10008.5.1.4.1.1.88.33	Explicit VR Big Endian Uncompressed 1.2.840.10008.1.2.2	O	M	O
Mammography CAD SR	1.2.840.10008.5.1.4.1.1.88.50	Explicit VR Little Endian Uncompressed 1.2.840.10008.1.2.1	M	M	O

Information Object Definitions	SOP Class UID	Transfer Syntax and UID	FSC	FSR	FSU
Mammography CAD SR	1.2.840.10008.5.1.4.1.1.88.50	Explicit VR Big Endian Uncompressed 1.2.840.10008.1.2.2	O	M	O
Chest CAD SR	1.2.840.10008.5.1.4.1.1.88.65	Explicit VR Little Endian Uncompressed 1.2.840.10008.1.2.1	M	M	O
Chest CAD SR	1.2.840.10008.5.1.4.1.1.88.65	Explicit VR Big Endian Uncompressed 1.2.840.10008.1.2.2	O	M	O
X-Ray Radiation Dose SR	1.2.840.10008.5.1.4.1.1.88.67	Explicit VR Little Endian Uncompressed 1.2.840.10008.1.2.1	M	M	O
X-Ray Radiation Dose SR	1.2.840.10008.5.1.4.1.1.88.67	Explicit VR Big Endian Uncompressed 1.2.840.10008.1.2.2	O	M	O
PET Image	1.2.840.10008.5.1.4.1.1.128	Explicit VR Little Endian Uncompressed 1.2.840.10008.1.2.1	M	M	O
PET Image	1.2.840.10008.5.1.4.1.1.128	JPEG Lossless Process 14 (selection value 1) 1.2.840.10008.1.2.4.70	O	M	O
PET Image	1.2.840.10008.5.1.4.1.1.128	Explicit VR Big Endian Uncompressed 1.2.840.10008.1.2.2	O	M	O
PET Image	1.2.840.10008.5.1.4.1.1.128	JPEG Lossy (baseline or extended) 1.2.840.10008.1.2.4.50 1.2.840.10008.1.2.4.51	O	O	O
PET Image	1.2.840.10008.5.1.4.1.1.128	RLE Lossless 1.2.840.10008.1.2.5	O	O	O
PET Image	1.2.840.10008.5.1.4.1.1.128	JPEG 2000 Lossless 1.2.840.10008.1.2.90	O	O	O



Information Object Definitions	SOP Class UID	Transfer Syntax and UID	FSC	FSR	FSU
PET Image	1.2.840.10008.5.1.4.1.1.128	JPEG 2000 Lossy 1.2.840.10008.1.2.91	O	O	O
RT Image	1.2.840.10008.5.1.4.1.1.481.1	Explicit VR Little Endian Uncompressed 1.2.840.10008.1.2.1	M	M	O
RT Image	1.2.840.10008.5.1.4.1.1.481.1	JPEG Lossless Process 14 (selection value 1) 1.2.840.10008.1.2.4.70	O	M	O
RT Image	1.2.840.10008.5.1.4.1.1.481.1	Explicit VR Big Endian Uncompressed 1.2.840.10008.1.2.2	O	M	O
RT Image	1.2.840.10008.5.1.4.1.1.481.1	JPEG Lossy (baseline or extended) 1.2.840.10008.1.2.4.50 1.2.840.10008.1.2.4.51	O	O	O
RT Image	1.2.840.10008.5.1.4.1.1.481.1	RLE Lossless 1.2.840.10008.1.2.5	O	O	O
RT Image	1.2.840.10008.5.1.4.1.1.481.1	JPEG 2000 Lossless 1.2.840.10008.1.2.90	O	O	O
RT Image	1.2.840.10008.5.1.4.1.1.481.1	JPEG 2000 Lossy 1.2.840.10008.1.2.91	O	O	O
RT Dose	1.2.840.10008.5.1.4.1.1.481.2	Explicit VR Little Endian Uncompressed 1.2.840.10008.1.2.1	M	M	O
RT Dose	1.2.840.10008.5.1.4.1.1.481.2	Explicit VR Big Endian Uncompressed 1.2.840.10008.1.2.2	O	M	O
RT Structure Set	1.2.840.10008.5.1.4.1.1.481.3	Explicit VR Little Endian Uncompressed 1.2.840.10008.1.2.1	M	M	O
RT Structure Set	1.2.840.10008.5.1.4.1.1.481.3	Explicit VR Big Endian Uncompressed 1.2.840.10008.1.2.2	O	M	O

Information Object Definitions	SOP Class UID	Transfer Syntax and UID	FSC	FSR	FSU
RT Beams Treatment Record	1.2.840.10008.5.1.4.1.1.481.4	Explicit VR Little Endian Uncompressed 1.2.840.10008.1.2.1	M	M	O
RT Beams Treatment Record	1.2.840.10008.5.1.4.1.1.481.4	Explicit VR Big Endian Uncompressed 1.2.840.10008.1.2.2	O	M	O
RT Plan	1.2.840.10008.5.1.4.1.1.481.5	Explicit VR Little Endian Uncompressed 1.2.840.10008.1.2.1	M	M	O
RT Plan	1.2.840.10008.5.1.4.1.1.481.5	Explicit VR Big Endian Uncompressed 1.2.840.10008.1.2.2	O	M	O
RT Brachy Treatment Record	1.2.840.10008.5.1.4.1.1.481.6	Explicit VR Little Endian Uncompressed 1.2.840.10008.1.2.1	M	M	O
RT Brachy Treatment Record	1.2.840.10008.5.1.4.1.1.481.6	Explicit VR Big Endian Uncompressed 1.2.840.10008.1.2.2	O	M	O
RT Treatment Summary Record	1.2.840.10008.5.1.4.1.1.481.7	Explicit VR Little Endian Uncompressed 1.2.840.10008.1.2.1	M	M	O
RT Treatment Summary Record	1.2.840.10008.5.1.4.1.1.481.7	Explicit VR Big Endian Uncompressed 1.2.840.10008.1.2.2	O	M	O
RT Ion Plan	1.2.840.10008.5.1.4.1.1.481.8	Explicit VR Little Endian Uncompressed 1.2.840.10008.1.2.1	M	M	O
RT Ion Plan	1.2.840.10008.5.1.4.1.1.481.8	Explicit VR Big Endian Uncompressed 1.2.840.10008.1.2.2	O	M	O
RT Ion Beams Treatment Record	1.2.840.10008.5.1.4.1.1.481.9	Explicit VR Little Endian Uncompressed 1.2.840.10008.1.2.1	M	M	O



Information Object Definitions	SOP Class UID	Transfer Syntax and UID	FSC	FSR	FSU
RT Ion Beams Treatment Record	1.2.840.10008.5.1.4.1.1.481.9	Explicit VR Big Endian Uncompressed 1.2.840.10008.1.2.2	O	M	O
Csa Non-Image	1.3.12.2.1107.5.9.1	Explicit VR Little Endian Uncompressed 1.2.840.10008.1.2.1	O	M	O

FSC, FSR, FSU - denote the requirement for those roles

O - Optional

M - Mandatory

Physical Media and Formats

The PRI-SYNGO-CD Profile requires the 120mm CD-R physical media with the ISO/IEC 9660 Media Format, as defined in PS3.12.

The PRI-SYNGO-DVD Profile requires the 120mm DVD-R physical media with the UDF 2.01 Media Format, as defined in PS3.12.

Directory Information in DICOMDIR

Conforming Application Entities shall include in the DICOMDIR File the Basic Directory IOD containing Directory Records at the Patient and subsidiary levels appropriate to the SOP Classes in the File Set. All DICOM files in the File Set incorporating SOP instances defined for the specific Application Profile shall be referenced by Directory Records.

Note

DICOMDIRs with no directory information are not allowed by this Application Profile

Privately defined IODs will be referenced by "PRIVATE" Directory Records.

Basic Directory IOD Specification

This Application Profile makes use of optional attributes of the Basic Directory IOD to support recognition of Patient's Storage Service request results in spanning multiple volumes (file sets). Therefore the File Set Descriptor File can be used and is then referenced by optional Basic Directory IOD attributes. If existent, the specified Descriptor File may be used by FSR applications. Any FSU, FSC shall make a clear statement if the Descriptor File mechanism is used according to the specialization defined in this Application Profile.

The Descriptor Files shall have the following contents:

One single line without any control characters and according to the Basic Character Set having the following defined text:

"MULTIVOLUME: xx of yy"

xx, yy are replaced by the actual number of the volume (xx) and the total number of volumes in the set (yy).

If used, the Descriptor File shall have the File ID "README" and reside in the same directory level as the DICOMDIR. It is referenced by the attribute [0004,1141] File Set Descriptor File ID having the defined contents of "README".

Additional Keys

File Set Creators and Updaters are required to generate the mandatory elements specified in PS 3.3, Annex F of the DICOM Standard. Table below: PRI-SYNGO-CD Additional DICOMDIR Keys specifies the additional associated keys. At each directory record level other additional data elements can be added, but it is not required that File Set Readers be able to use them as keys. Refer to the Basic Directory IOD in PS 3.3.

Attribute Name	Tag	Directory Record Level	Type	Notes
Date Of Birth	(0010,0030)	PATIENT	2C	required, if present in SOP Instance
Patient's Sex	(0010,0040)	PATIENT	2C	required, if present in SOP Instance
Series Date	(0008,0021)	SERIES	3	
Series Time	(0008,0031)	SERIES	3	
Institution name	(0008,0080)	SERIES	2C	required, if present in SOP Instance
Institution Address	(0008,0081)	SERIES	2C	required, if present in SOP Instance
Series Description	(0008,103E)	SERIES	3	
Performing Physician	(0008,1050)	SERIES	2C	required, if present in SOP Instance
Image Type	(0008,0008)	IMAGE	1C	required, if present in SOP Instance
Content Date	(0008,0023)	IMAGE	3	
Content Time	(0008,0033)	IMAGE	3	
Referenced Image Sequence	(0008,1140)	IMAGE	1C	required, if present in SOP Instance
> Referenced SOP Class UID	(0008,1150)			
> Referenced SOP Instance UID	(0008,1155)			

Attribute Name	Tag	Directory Record Level	Type	Notes
Image Position (Patient)	(00020,0032)	IMAGE	2C	required, if present in SOP Instance
Image Orientation (Patient)	(0020,0037)	IMAGE	2C	required, if present in SOP Instance
Frame Of Reference UID	(0020,0052)	IMAGE	2C	required, if present in SOP Instance
Rows	(0028,0010)	IMAGE	3	
Columns	(0028,0011)	IMAGE	3	
Pixel Spacing	(0028,0030)	IMAGE	1C	C
Calibration Image	(0050,0004)	IMAGE	2C	required, if present in SOP Instance
Icon Image Sequence	(0088,0200)	IMAGE	3	required for Image SOP Classes
> Samples per Pixel	(0028,0002)			1
> Photometric Interpretation	(0028,0004)			MONOCHROME2
> Rows	(0028,0010)			128 for XA IOD, 64 otherwise
> Columns	(0028,0011)			128 for XA IOD, 64 otherwise
> Bits Allocated	(0028,0100)			8
> Bits Stored	(0028,0101)			8
> High Bit	(0028,0102)			7
> Pixel Representation	(0028,0103)			0 (unsigned)
> Pixel Data	(7FE0,0010)			Icon Image pixel data
Curve Number	(0020,0024)	CURVE	1C	required, if present in SOP Instance

Private Directory Record Keys

Private Directory Records are supported by this Application Profile Class at the following level:

IMAGE

The PRIVATE Directory Records will have required elements in addition to the mandatory elements specified in PS 3.3.

The following table will list the additional required keys for PRIVATE Directory Records.

Attribute Name	Tag	Directory Record Level	Type	Notes
Private Record UID	(0004,1432)	PRIVATE	1	See Conformance Statement
SOP Class UID	(0008,0016)	PRIVATE	1C	required, if present in SOP Instance
SOP Instance UID	(0008,0018)	PRIVATE	1C	required, if present in SOP Instance
Image Type	(0008,0008)	PRIVATE	3	identification characteristics
Acquisition Date	(0008,0022)	PRIVATE	3	
Acquisition Time	(0008,0032)	PRIVATE	3	
Acquisition Number	(0020,0012)	PRIVATE	3	
CSA Data Type	(0029,xx08)	PRIVATE	1	private owner code = SIEMENS CSA NON-IMAGE
CSA Data Version	(0029,xx09)	PRIVATE	3	private owner code = SIEMENS CSA NON-IMAGE

Icon Images

Directory Records of type SERIES or IMAGE may include Icon Images. The Icon Image Pixel data shall be as specified in PS 3.3 "Icon Image Key Definition", and restricted such, that Bits Allocated (0028,0100) and Bits Stored (0028,0101) shall be equal to 8, and Rows (0028,0010) and Columns (0028,0011) shall be equal to 128 for XA Images and 64 for all other images. The Photometric interpretation (0028,0004) shall always be restricted to "MONOCHROME2".

PRIVATE Directory Records will not contain Icon Image information.

Other Parameters

This section defines other parameters common to all specific Application Profiles in the PRI-SYNGO class which need to be specified in order to ensure interoperable media interchange.

Multiframe JPEG Format

The JPEG encoding of pixel data shall use Interchange Format (with table specification) for all frames.



CHAPTER B.4

Extensions, Specializations and Privatizations of SOP Classes and Transfer Syntaxes

The SOP Classes listed refer in majority to those created by the equipment to which this Conformance Statement is related to. For SOP classes not listed in this section, please refer to the Storage section of the DICOM Conformance Statement of the product. This will include all SOP Instances that can be received and displayed and therefore will be included into offline media storage even though these SOP Instances are not created by the equipment serving the Media Storage Service.

SOP Specific Conformance Statement for Basic Directory

Extension, Specialization for SIEMENS Non-Image Objects

According to the PRI-SYNGO Application Profile Class the usage of the Private Creator UIDs and further optional keys for the Directory Records referring to SIEMENS Non-Image Objects are listed in the following table.

Attribute	Tag	Value used
Private Record UID	(0004,1432)	1.3.12.2.1107.5.9.1
SOP Class UID	(0008,0016)	1.3.12.2.1107.5.9.1

For the Non-Images no Icon Image Sequence will be generated.

AE Title Mapping

DICOM Media Storage AE Title

The DICOM Storage application (Image Manager) provides the application entity title:

CsImageManager



CHAPTER B.6

Support of Extended Character Sets

The Somaris/5 DICOM application supports the following character sets as defined in the three tables below:

Single-Byte Character Sets without Code Extension

Character Set Description	Defined Term	ISO registration number	Character Set
Default repertoire	none	ISO_IR 6	ISO 646:
Latin alphabet No. 1	ISO_IR 100	ISO_IR 100	Supplementary set
		ISO_IR 6	ISO 646:
Latin alphabet No. 2	ISO_IR 101	ISO_IR 101	Supplementary set
		ISO_IR 6	ISO 646
Latin alphabet No. 3	ISO_IR 109	ISO_IR 109	Supplementary set
		ISO_IR 6	ISO 646
Latin alphabet No. 4	ISO_IR 110	ISO_IR 110	Supplementary set
		ISO_IR 6	ISO 646
Cyrillic	ISO_IR 144	ISO_IR 144	Supplementary set
		ISO_IR 6	ISO 646
Arabic	ISO_IR 127	ISO_IR 127	Supplementary set
		ISO_IR 6	ISO 646
Greek	ISO_IR 126	ISO_IR 126	Supplementary set
		ISO_IR 6	ISO 646
Hebrew	ISO_IR 138	ISO_IR 138	Supplementary set
		ISO_IR 6	ISO 646
Latin alphabet No. 5	ISO_IR 148	ISO_IR 148	Supplementary set
		ISO_IR 6	ISO 646

Single-Byte Character Sets without Code Extension

Character Set Description	Defined Term	ISO registration number	Character Set
Japanese	ISO_IR 13	ISO_IR 13	JIS X 0201: Katakana
		ISO_IR 14	JIS X 0201: Romaji

Single-Byte Character Sets with Code Extension

Character Set Description	Defined Term	Standard for Code Extension	ESC sequence	ISO registration number	Character Set
Default repertoire	ISO 2022 IR 6	ISO 2022	ESC 02/08 04/02	ISO-IR 6	ISO 646
Latin alphabet No.1	ISO 2022 IR 100	ISO 2022	ESC 02/13 04/01	ISO-IR 100	Supplementary set
		ISO 2022	ESC 02/08 04/02	ISO-IR 6	ISO 646
Latin alphabet No.2	ISO 2022 IR 101	ISO 2022	ESC 02/13 04/02	ISO-IR 101	Supplementary set
		ISO 2022	ESC 02/08 04/02	ISO-IR 6	ISO 646
Latin alphabet No.3	ISO 2022 IR 109	ISO 2022	ESC 02/13 04/03	ISO-IR 109	Supplementary set
		ISO 2022	ESC 02/08 04/02	ISO-IR 6	ISO 646

Single-Byte Character Sets with Code Extension					
Character Set Description	Defined Term	Standard for Code Extension	ESC sequence	ISO registration number	Character Set
Latin alphabet No.4	ISO 2022 IR 110	ISO 2022	ESC 02/13 04/04	ISO-IR 110	Supplementary set
		ISO 2022	ESC 02/08 04/02	ISO-IR 6	ISO 646
Cyrillic	ISO 2022 IR 144	ISO 2022	ESC 02/13 04/12	ISO-IR 144	Supplementary set
		ISO 2022	ESC 02/08 04/02	ISO-IR 6	ISO 646
Arabic	ISO 2022 IR 127	ISO 2022	ESC 02/13 04/07	ISO-IR 127	Supplementary set
		ISO 2022	ESC 02/08 04/02	ISO-IR 6	ISO 646
Greek	ISO 2022 IR 126	ISO 2022	ESC 02/13 04/06	ISO-IR 126	Supplementary set
		ISO 2022	ESC 02/08 04/02	ISO-IR 6	ISO 646
Hebrew	ISO 2022 IR 138	ISO 2022	ESC 02/13 04/08	ISO-IR 138	Supplementary set
		ISO 2022	ESC 02/13 04/02	ISO-IR 6	ISO 646
Latin alphabet No.5	ISO 2022 IR 148	ISO 2022	ESC 02/13 04/13	ISO-IR 148	Supplementary set
		ISO 2022	ESC 02/13 04/02	ISO-IR 6	ISO 646



Single-Byte Character Sets with Code Extension

Character Set Description	Defined Term	Standard for Code Extension	ESC sequence	ISO registration number	Character Set
Japanese	ISO 2022 IR 13	ISO 2022	ESC 02/13 04/09	ISO-IR 13	JIS X 0201: Katakana
		ISO 2022	ESC 02/13 04/10	ISO-IR 14	JIS X 0201-1976: Romaji

Multi-Byte Character Sets without Code Extension

Character Set Description	Defined Term	ISO registration number	Character Set
Unicode	ISO_IR 192	ISO 10646	Unicode in UTF-8
Chinese	GB18030	GB18030	GB 18030-2000 (China Association for Standardization)

Multi-Byte Character Sets with Code Extension

Character Set Description	Defined Term	Standard for Code Extension	ESC sequence	ISO registration number	Character Set
Japanese	ISO 2022 IR 87	ISO 2022	ESC 02/04 04/02	ISO-IR 87	JIS X 0208: Kanji
	ISO 2022 IR 159	ISO 2022	ESC 02/04 02/08 04/ 04	ISO-IR 159	JIS X 0212: Supplementary Kanji set
Chinese ^a	ISO 2022 IR 58	ISO 2022	ESC 02/04 04/01	ISO-IR 58	GB2312-80 (China Association for Standardization)

a. This Character Set is an extension of DICOM for the Chinese language.

When there is a mismatch between the SCS tags (0008,0005) and the characters in an IOD received by the system, then the following measures are taken to make the characters DICOM conform:

- Try to import with ISO_IR 100. If ISO_IR 100 fails, convert each illegal character to a '?'.
 - There are now three categories of character sets which have to be differentiated because of their different encoding formats:
 - Conventional ISO character sets: ISO_IR 6, ISO 2022 IR 6, ISO_IR 100, etc.
 - encoded in ISO 2022
 - ISO_IR 192 → encoded in UTF-8
 - GB18030 → encoded in GB18030

It is not possible to recognize the following mismatches automatically on receiving or importing:

- ❑ An attribute value is encoded in ISO_IR 192 \leftrightarrow (0008,0005) contains a conventional ISO character set as primary character set
- ❑ An attribute value is encoded in GB18030 \leftrightarrow (0008,0005) contains a conventional ISO character set as primary character set
- ❑ An attribute value is encoded in ISO 2022 \leftrightarrow (0008,0005) contains ISO_IR 192
- ❑ An attribute value is encoded in ISO 2022 \leftrightarrow (0008,0005) contains GB18030

An IOD that contains one of the above mentioned inconsistencies is not DICOM conform. As these kinds of inconsistencies cannot be recognized by the system, the IOD will not be rejected but the character data might be corrupted.

Older versions of syngo do not support the newly introduced character sets ISO_IR 192 and GB18030 and their special encodings. That means, an IOD which contains one of these new character sets in (0008,0005) will be rejected by an older *syngo* system.

Annex

Siemens Private Non-Image IOD

Please see section

→ page A.4–95, *Private SOP class CSA Non-Image*.

Siemens Standard Extended Modules

Please see section

→ page A.4–85, *All syngo Supported Image SOP Classes*.

Siemens Standard Extended Modules

Please see section

→ page A.4–81, *Registry of DICOM Data Elements*
and → page A.4–93, *Registry of DICOM Data Elements*.

DICOM Print SCU-detailed status displays

Please see section

→ page A.2–105, *DICOM Print SCU - detailed status displays*.

Additional DICOM Conformance Statement for VSim

Please see document DICOM Conformance Statement VSim.

© 2011, Siemens AG
Order No.
C2-023.610.15.01.02
Printed in Germany
08/2011

Global Business Unit

Siemens AG
Medical Solutions
Computed Tomography & Radiation Oncology
Siemensstr.1
DE-91301 Forchheim
Germany
Phone: +49 9191 18-0
www.siemens.com/computedtomography

Global Siemens Headquarters

Siemens AG
Wittelsbacherplatz 2
80333 Muenchen
Germany

Global Siemens Healthcare Headquarters

Siemens AG
Healthcare Sector
Henkestrasse 127
91052 Erlangen
Germany
Phone: +49 9131 840
www.siemens.com/healthcare

Legal Manufacturer

Siemens AG
Wittelsbacherplatz 2
DE-80333 Muenchen
Germany