

SIEMENS

SOMATOM *syngo* VA45C

CT

DICOM Conformance Statement

Version A45C

© Siemens AG 2003
All rights reserved

Siemens AG, Medical Engineering Group, Computed Tomography
Siemensstr. 1, D-91301 Forchheim, Germany

Headquarters: Berlin and Munich
Siemens AG, Wittelsbacher Platz 2, D-80333 Munich, Germany

Print No. C2-019.610.23.01.02
Printed in the Federal Republic of Germany
Release 05.03





Manufacturer's note:

This product bears a CE marking in accordance with the provisions of directive 93/42/EEC of June 14th, 1993 for medical products.

The CE marking applies only to medico-technical products/medical products introduced in connection with the above-mentioned comprehensive EC directives.



Table of Contents

Introduction

A *DICOM Conformance Statement Network*

- A.1 Implementation Model
- A.2 Application Entity Specifications
- A.3 Communication Profiles
- A.4 Extensions/Specializations/Privatizations
- A.5 Configuration
- A.6 Support of Extended Character Sets

B *DICOM Conformance Statement Media Storage*

- B.1 Implementation Model
- B.2 Application Entity Specifications
- B.3 Augmented and Private Profiles
- B.4 Extensions, Specializations and Privatizations of SOP Classes and Transfer Syntaxes
- B.5 Configuration
- B.6 Support of Extended Character Sets



Introduction

Overview

This DICOM Conformance Statement is written according to part PS 3.2 of [1].

The applications described in this conformance statement are implemented in the Siemens SOMATOM products using software Somaris/5 VA45C.

The Somaris/5 DICOM network implementation acts as SCU and SCP for the DICOM Verification, Storage, Storage Commitment Push Model, and Query/Retrieve Services. It acts as SCU for the DICOM Print Management Service, the Modality Worklist Service, and the Performed Procedure Step Service.

These services are described in "Part I".

The Somaris/5 DICOM Media Storage Service implementation acts as FSC, FSU, and FSR for the specified application profiles and the related SOP Class instances. These services are described in "Part II".

Somaris/5 is based on a Siemens common medical platform. This platform is shared with other Siemens modalities in order to provide a common look and feel and common interoperability features.

In this document parts of the Siemens common medical platform are referenced by the terms "*syngo*[®]", "MedCom", and "CSA".

As Somaris/5 is a *syngo* based product, this DICOM Conformance Statement is based on the corresponding *syngo* template [2].

Audience

This document is intended for hospital staff, health system integrators, hospital IT-managers, and software designers or implementors. It is assumed that the reader has a working understanding of DICOM.

Scope

This DICOM Conformance Statement refers to Siemens SOMATOM products using software Somaris/5. The following table relates software names to Siemens products.

Software Name	SIEMENS Product
Somaris/5 VA45C	Huan Yue Shuang
Somaris/5 VA45C	Huan Yue

Definitions, Acronyms and Abbreviations

Definitions

- ❑ **DICOM**: Digital Imaging and Communications in Medicine
- ❑ **DIMSE**: DICOM Message Service Element
- ❑ **DIMSE-C**: DICOM Message Service Element with Composite information objects

Acronyms and Abbreviations

- ❑ **ACR**: American College of Radiology
- ❑ **AE**: DICOM Application Entity
- ❑ **ASCII**: American Standard Code for Information Interchange
- ❑ **FSC**: File Set Creator
- ❑ **FSR**: File Set Reader
- ❑ **FSU**: File Set Updater
- ❑ **HIS**: Hospital Information System
- ❑ **IOD**: DICOM Information Object Definition
- ❑ **ISO**: International Standard Organization
- ❑ **NEMA**: National Electrical Manufacturers Association
- ❑ **O**: Optional Key Attribute
- ❑ **R**: Required Key Attribute
- ❑ **RIS**: Radiology Information System
- ❑ **RWA**: Real-World Activity
- ❑ **PDU**: DICOM Protocol Data Unit
- ❑ **SCU**: DICOM Service Class User (DICOM client)
- ❑ **SCP**: DICOM Service Class Provider (DICOM server)
- ❑ **SOP**: DICOM Service-Object Pair
- ❑ **U**: Unique Key Attribute
- ❑ **UID**: Unique Identifier
- ❑ **VR**: Value Representation

References

[1]: Digital Imaging and Communications in Medicine (DICOM) 3.0, NEMA PS 3.1-3.14

[2]: *syngo* VB10B DICOM Conformance Statement

Connectivity and Interoperability

The implementation of the Somaris/5 DICOM interface has been carefully tested to assure correspondence with this Conformance Statement. But the Conformance Statement and the DICOM standard do not guarantee interoperability of Siemens modalities and modalities of other vendors. The user must compare the relevant Conformance Statements and if a successful interconnection should be possible, the user is responsible to specify an appropriate test suite and to validate the interoperability, which is required. A network environment may need additional functions out of the scope of DICOM.

If you are using the software with a Chinese UI, be aware of the notes in chapters A.6 and B.6.

DICOM *Conformance Statement*

Network



Verification

The Verification service class defines an application-level class of service which allows for the operator to verify the ability of an application on a remote node to respond to DICOM messages. The DICOM Service Tool application supports the Verification service to act as SCU.

The other direction – responding to Verification requests from remote applications – is handled by the Storage SCP application.

Application Data Flow Diagram

The Somaris/5 DICOM network implementation is a Windows NT application and acts as SCU for the Verification service.

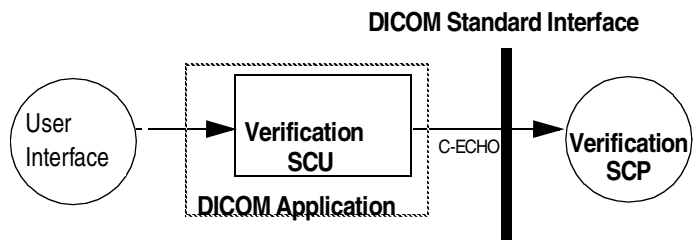

Functional Definitions of Application Entities

The DICOM Service Tool application opens an association to an application on the remote node and sends a Verification message to verify that the remote application can respond to DICOM messages.

Sequencing of Real-World Activities

Not applicable.

Storage

The Somaris/5 DICOM Application Entity originates associations for Storage of DICOM Composite Information Objects in Remote Application Entities.

Application Data Flow Diagram

The Somaris/5 DICOM network implementation is a Windows NT application and acts as SCU and SCP for the C-STORE DICOM network service and as SCP for the C-ECHO DICOM network service.

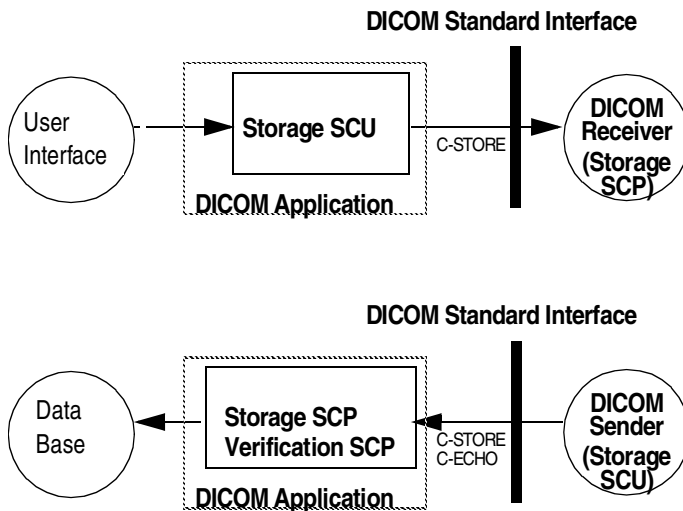

Functional Definitions of Application Entities

All SCP components of the Siemens Somaris/5 DICOM application are operating as background daemon processes. They are existing, when the machine is powered on and waiting for tasks.

Sequencing of Real-World Activities

Not applicable.

Storage Commitment Push Model

The Storage Commitment service class defines an application-level class of service which facilitates the commitment to storage. It performs an additional task of commitment of composite objects apart from the network based storage of images as defined by the Storage Service class.

Application Data Flow Diagram

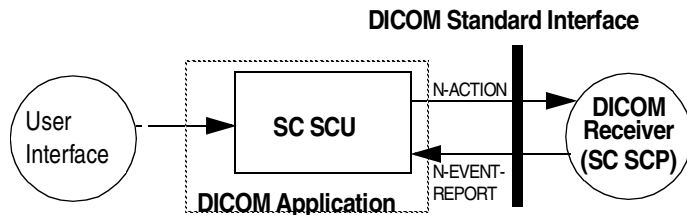

Functional Definitions of Application Entities

The Storage Commitment Push Model SCU (SC-SCU) uses the Storage Commitment Service Class to get commitment for one or more composite objects from the Storage Commitment Push Model SCP (SC-SCP). SC-SCU issues an N-ACTION to SC-SCP containing a list of references to composite objects, requesting that the SC-SCP takes responsibility for storage commitment of the composite objects. If the SC-SCP has determined that all the composite objects exist and it has successfully completed storage commitment for the set of composite objects, it issues an N-EVENT-REPORT with status successful and the list of stored images. SC-SCU now knows that the composite objects have been committed by SC-SCP and can delete its copies of composite objects. The information from the N_EVENT-REPORT is propagated back to the user interface.

If committed storage cannot be done for some reason for any of the list of composite objects the SC_SCP issues an N-EVENT-REPORT with a status of completed-failures exist and would include both the successful and failed list. The *syngo* SCU can be configured to receive the N_EVENT_REPORT on the same association on which N_ACTION was sent or on a different association.

Sequencing of real World Activities

Not applicable.

Query/Retrieve

The query/retrieve service class defines an application-level class of services which facilitates the management of images and patient data against the well defined information model of DICOM and allows a DICOM AE to retrieve images from a remote DICOM node or to request a remote DICOM AE to initiate a transfer of images to another DICOM AE. The DICOM query/retrieve application supports the query/retrieve services to act as SCU and SCP.

Application Data Flow Diagram

The Somaris/5 DICOM network implementation is a Windows NT application and acts as SCU and SCP for the query/retrieve network service.

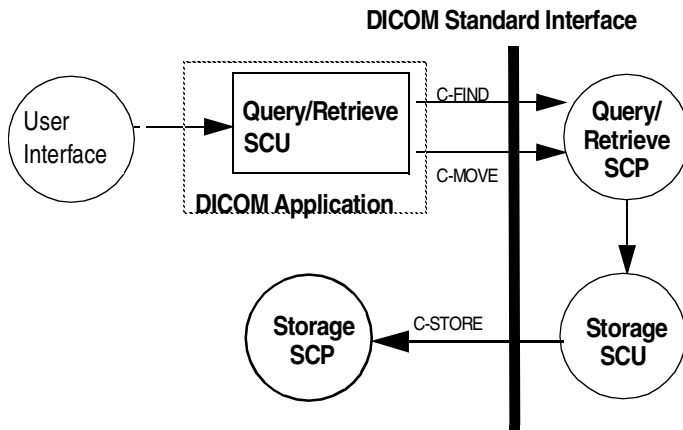

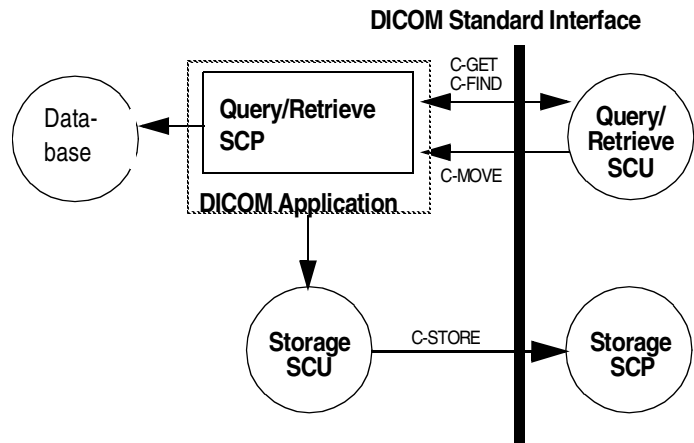

Functional Definitions of Application Entities

The query/retrieve SCU requests the query/retrieve SCP to perform a match to the keys specified in the request and a C-MOVE DIMSE service initiates a C-STORE suboperation to transfer an image from a Storage SCU to a Storage SCP.

The query/retrieve SCP responds to C-FIND DIMSE services and a C-GET or a C-MOVE involves the Somaris/5 DICOM query/retrieve SCP application to initiate a C-STORE suboperation to a Storage SCP.

All components of the Somaris/5 DICOM query/retrieve SCP application are operating as background daemon processes. They are existing, when the machine is powered on and respond to queries based on the records stored in its database.

Sequencing of Real-World Activities

Not applicable.

Print

The Print Management Service Classes define an application-level class of services which facilitate the printing of images on a hardcopy medium. The print management SCU and print management SCP are peer DICOM print management application entities. The DICOM print application supports the print management DIMSE services to act as SCU.

Application Data Flow Diagram

The Somaris/5 DICOM network implementation is a Windows NT application and acts as SCU for the print management network service.

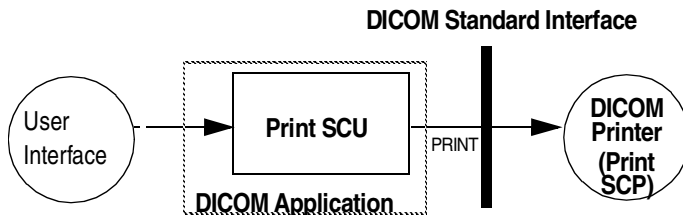

Functional Definitions of Application Entities

The user invokes a print job and the SCU uses the SOP classes of a film session, a film box and image boxes for acquiring all the information which is required for a film session. The N-ACTION is used to print the film session. The DIMSE services of the Printer SOP Class and the Print Job SOP Class allow the SCU to control the print jobs and printer status informations of the SCP.

Sequencing of Real-World Activities

Not applicable.

Modality Worklist

The Modality Worklist service class defines an application-level class of service which facilitates the transfer of worklists from the information system to the imaging modality. The worklist is queried by the AE and supplies the SCU with the scheduled tasks which have to be performed on the modality. The DICOM worklist application supports the worklist service to act as SCU.

Application Data Flow Diagram

The Somaris/5 DICOM network implementation is a Windows NT application and acts as SCU for the worklist network service.

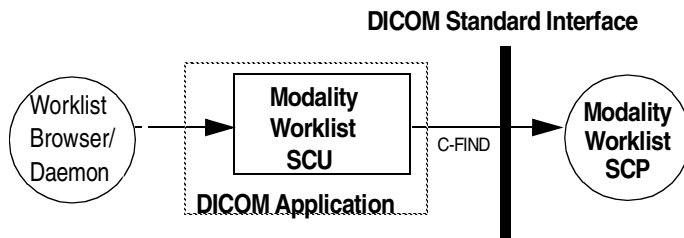

Note: It is configurable to get the worklist updates either automatically (in a configurable time interval) or manually (initiated by the user). There are two kinds of query the user can do: broad worklist query (all jobs for the own modality or own application entity) and patient based worklist query (where more search keys can be given, including Patient Name and Patient ID).

Functional Definitions of Application Entities

The basic worklist SCU requests the worklist SCP to perform a match to the keys specified in the C-FIND DIMSE service.

The worklist SCP responds to the C-FIND query and sends scheduled imaging service requests and patient demographic information from the information system to the modality.

Sequencing of Real-World Activities

Not applicable.

Modality Performed Procedure Step

The Modality Performed Procedure Step service class defines an application-level class of service which facilitates the transfer of billing and radiation dose information from the imaging modality to the information system. The performed procedure step is sent by the AE and supplies the SCP with the performed tasks on the modality. The DICOM performed procedure step application supports the performed procedure step service to act as SCU.

Application Data Flow Diagram

The Somaris/5 DICOM network implementation is a Windows NT application and acts as SCU for the worklist network service.

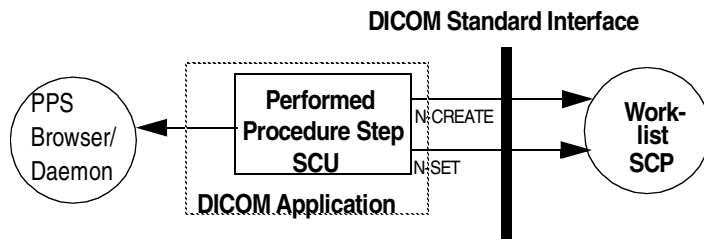

Functional Definitions of Application Entities

The modality performed procedure step SCU informs the performed procedure step SCP about the performed procedure steps examined at the modality in the N-CREATE and N-SET DIMSE service.

The modality performed procedure step SCP responds to the N-CREATE and N-SET and confirms that it received the information from the modality.

Sequencing of real-World Activities

Not applicable.



Verification AE Specification

Association Initiation by Real-World Activity

The Somaris/5 DICOM Service Tool application attempts to initiate a new association for

- DIMSE C-ECHO

service operations.

Real-World Activity - Verification SCU

The associated Real-World activity is a C-ECHO request initiated by the DICOM Service Tool application. If the process successfully establishes an association to a remote Application Entity, it will send the C-ECHO-Request via the open association to verify that the remote Application Entity is responding to DICOM messages.

Associated Real-World Activity - Verification SCU

Proposed Presentation Contexts - Verification SCU

The Somaris/5 DICOM application will propose Presentation Contexts as shown in the following table:

Presentation Context Table					
Abstract Syntax		Transfer Syntax		Role	Extended
Name	UID	Name List	UID List		Negotiation
Verification	1.2.840.10008.1.1	Implicit VR Little Endian	1.2.840.10008.1.2	SCU	None

SOP Specific Conformance Statement - Verification SCU

The Application conforms to the definition of a Verification SCU in accordance to the DICOM Standard.

Association Acceptance Policy

The Verification SCP is part of the Storage SCP – see → page A.2–13, *Association Acceptance Policy*.

Storage AE Specification

Somaris/5 DICOM implementation provides Standard Conformance to the following DICOM V3.0 SOP Classes as both an SCU and SCP:

SOP Class Name	SOP Class UID
CR Image Storage	1.2.840.10008.5.1.4.1.1.1
Digital X-Ray Image Storage - For Presentation	1.2.840.10008.5.1.4.1.1.1.1
Digital X-Ray Image Storage - For Processing	1.2.840.10008.5.1.4.1.1.1.1.1
Digital Mammography X-Ray Image Storage - For Presentation	1.2.840.10008.5.1.4.1.1.1.2
Digital Mammography X-Ray Image Storage - For Processing	1.2.840.10008.5.1.4.1.1.1.2.1
CT Image Storage	1.2.840.10008.5.1.4.1.1.2
US Multi-Frame Image Storage	1.2.840.10008.5.1.4.1.1.3.1
MR Image Storage	1.2.840.10008.5.1.4.1.1.4
US Image Storage	1.2.840.10008.5.1.4.1.1.6.1
SC (Secondary Capture) Image Storage	1.2.840.10008.5.1.4.1.1.7
12-lead ECG Waveform Storage	1.2.840.10008.5.1.4.1.1.9.1.1
General ECG Waveform Storage	1.2.840.10008.5.1.4.1.1.9.1.2
Ambulatory ECG Waveform Storage	1.2.840.10008.5.1.4.1.1.9.1.3
Hemodynamic Waveform Storage	1.2.840.10008.5.1.4.1.1.9.2.1
Cardiac Electrophysiology Waveform Storage	1.2.840.10008.5.1.4.1.1.9.3.1



SOP Class Name	SOP Class UID
Basic Voice Audio Waveform Storage	1.2.840.10008.5.1.4.1.1.9.4.1
XA (X-Ray Angiographic) Image Storage	1.2.840.10008.5.1.4.1.1.12.1
XRF (X-Ray Radiofluoroscopic) Image Storage	1.2.840.10008.5.1.4.1.1.12.2
XA Bi-Plane (X-Ray Angiographic Bi-Plane) Image Storage (Retired)	1.2.840.10008.5.1.4.1.1.12.3
XRF (X-Ray Radiofluoroscopic) Image Storage	1.2.840.10008.5.1.4.1.1.12.2
NM Image Storage	1.2.840.10008.5.1.4.1.1.20
PET Image Storage	1.2.840.10008.5.1.4.1.1.128
RT Structure Set Storage	1.2.840.10008.5.1.4.1.1.481.3
Verification (only SCP)	1.2.840.10008.1.1

Somaris/5 DICOM implementation provide Private Conformance to the following DICOM V3.0 conform Private SOP Classes as both an SCU and SCP:

SOP Class Name	SOP Class UID
CSA Non-Image Storage	1.3.12.2.1107.5.9.1

Association Establishment Policies

General

The configuration of the Somaris/5 DICOM application defines the Application Entity Titles, the port numbers and of course the host name and net address.

Number of Associations

The Somaris/5 DICOM application initiates several associations at a time, one for each transfer request being processed.

Asynchronous Nature

The Somaris/5 DICOM implementation does not support asynchronous communication (multiple outstanding transactions over a single association).

Implementation Identifying Information

The Somaris/5 DICOM implementation provides the Implementation Class UID of

❑ "1.3.12.2.1107.5.1.4"

and an Implementation Version Name of

❑ "SIEMENS_S5VA45C".

Maximum PDU Size offered

❑ The maximum PDU size offered by *syngo* is configurable with default set to 28672 Bytes.

Dicom Application Context

❑ Dicom Application context name: 1.2.840.10008.3.1.1.1



Association Initiation by Real-World Activity

The Somaris/5 DICOM application attempts to initiate a new association for

- DIMSE C-STORE

service operations.

Real-World Activity - Storage SCU

The associated Real-World activities are:

- A user wants to send one or more composite objects to a remote node.
- The local C-MOVE SCP initiates C-STORE suboperations as a reaction to a C-MOVE-RQ coming from a remote node.

For both cases, if the process successfully establishes an association to a remote Application Entity, it will transfer each image one after another via the open association. If the C-STORE Response from the remote Application Entity contains an error status the association is aborted or released.

Associated Real-World Activity - Storage SCU

Proposed Presentation Contexts - Storage SCU

The Somaris/5 DICOM application will propose Presentation Contexts as shown in the following table:

Presentation Context Table					
Abstract Syntax		Transfer Syntax		Role	Extended
Name	UID	Name List	UID List		Negotiation
CR Image Storage SOP class	1.2.840.10008.5.1.4.1.1.1	Implicit VR Little Endian	1.2.840.10008.1.2	SCU	None
		Explicit VR Big Endian	1.2.840.10008.1.2.2		
		Explicit VR Little Endian	1.2.840.10008.1.2.1		
		JPEG Baseline	1.2.840.10008.1.2.4.50		
		JPEG Extended (2 & 4)	1.2.840.10008.1.2.4.51		
		JPEG Lossless	1.2.840.10008.1.2.4.70		
		Non-Hierarchical			



CT Image Storage SOP class	1.2.840.10008.5.1.4.1.1.2	Implicit VR Little Endian	1.2.840.10008.1.2	SCU	None
		Explicit VR Big Endian	1.2.840.10008.1.2.2		
		Explicit VR Little Endian	1.2.840.10008.1.2.1		
		JPEG Baseline	1.2.840.10008.1.2.4.50		
		JPEG Extended (2 & 4)	1.2.840.10008.1.2.4.51		
		JPEG Lossless	1.2.840.10008.1.2.4.70		
		Non-Hierarchical			
MR Image Storage SOP class	1.2.840.10008.5.1.4.1.1.4	Implicit VR Little Endian	1.2.840.10008.1.2	SCU	None
		Explicit VR Big Endian	1.2.840.10008.1.2.2		
		Explicit VR Little Endian	1.2.840.10008.1.2.1		
		JPEG Baseline	1.2.840.10008.1.2.4.50		
		JPEG Extended (2 & 4)	1.2.840.10008.1.2.4.51		
		JPEG Lossless	1.2.840.10008.1.2.4.70		
		Non-Hierarchical			
NM Image Storage SOP class	1.2.840.10008.5.1.4.1.1.20	Implicit VR Little Endian	1.2.840.10008.1.2	SCU	None
		Explicit VR Big Endian	1.2.840.10008.1.2.2		
		Explicit VR Little Endian	1.2.840.10008.1.2.1		
		JPEG Baseline	1.2.840.10008.1.2.4.50		
		JPEG Extended (2 & 4)	1.2.840.10008.1.2.4.51		
		JPEG Lossless	1.2.840.10008.1.2.4.70		
		Non-Hierarchical			
SC Image Storage SOP class	1.2.840.10008.5.1.4.1.1.7	Implicit VR Little Endian	1.2.840.10008.1.2	SCU	None
		Explicit VR Big Endian	1.2.840.10008.1.2.2		
		Explicit VR Little Endian	1.2.840.10008.1.2.1		
		JPEG Baseline	1.2.840.10008.1.2.4.50		
		JPEG Extended (2 & 4)	1.2.840.10008.1.2.4.51		
		JPEG Lossless	1.2.840.10008.1.2.4.70		
		Non-Hierarchical			
XA Image Storage SOP class	1.2.840.10008.5.1.4.1.1.12.1	Implicit VR Little Endian	1.2.840.10008.1.2	SCU	None
		Explicit VR Big Endian	1.2.840.10008.1.2.2		
		Explicit VR Little Endian	1.2.840.10008.1.2.1		
		JPEG Baseline	1.2.840.10008.1.2.4.50		
		JPEG Extended (2 & 4)	1.2.840.10008.1.2.4.51		
		JPEG Lossless	1.2.840.10008.1.2.4.70		
		Non-Hierarchical			

XA Bi-Plane Image Storage SOP class (Retired)	1.2.840.10008.5.1.4.1.1.12.3	Implicit VR Little Endian	1.2.840.10008.1.2	SCU	None
		Explicit VR Big Endian	1.2.840.10008.1.2.2		
		Explicit VR Little Endian	1.2.840.10008.1.2.1		
		JPEG Baseline	1.2.840.10008.1.2.4.50		
		JPEG Extended (2 & 4)	1.2.840.10008.1.2.4.51		
		JPEG Lossless	1.2.840.10008.1.2.4.70		
		Non-Hierarchical			
XRF Image Storage SOP class	1.2.840.10008.5.1.4.1.1.12.2	Implicit VR Little Endian	1.2.840.10008.1.2	SCU	None
		Explicit VR Big Endian	1.2.840.10008.1.2.2		
		Explicit VR Little Endian	1.2.840.10008.1.2.1		
		JPEG Baseline	1.2.840.10008.1.2.4.50		
		JPEG Extended (2 & 4)	1.2.840.10008.1.2.4.51		
		JPEG Lossless	1.2.840.10008.1.2.4.70		
		Non-Hierarchical			
US MF Image Storage SOP class	1.2.840.10008.5.1.4.1.1.3.1	Implicit VR Little Endian	1.2.840.10008.1.2	SCU	None
		Explicit VR Big Endian	1.2.840.10008.1.2.2		
		Explicit VR Little Endian	1.2.840.10008.1.2.1		
		JPEG Baseline	1.2.840.10008.1.2.4.50		
		JPEG Extended (2 & 4)	1.2.840.10008.1.2.4.51		
		JPEG Lossless	1.2.840.10008.1.2.4.70		
		Non-Hierarchical			
US Image Storage SOP class	1.2.840.10008.5.1.4.1.1.6.1	Implicit VR Little Endian	1.2.840.10008.1.2	SCU	None
		Explicit VR Big Endian	1.2.840.10008.1.2.2		
		Explicit VR Little Endian	1.2.840.10008.1.2.1		
		JPEG Baseline	1.2.840.10008.1.2.4.50		
		JPEG Extended (2 & 4)	1.2.840.10008.1.2.4.51		
		JPEG Lossless	1.2.840.10008.1.2.4.70		
		Non-Hierarchical			
PET Image Storage SOP class	1.2.840.10008.5.1.4.1.1.128	Implicit VR Little Endian	1.2.840.10008.1.2	SCU	None
		Explicit VR Big Endian	1.2.840.10008.1.2.2		
		Explicit VR Little Endian	1.2.840.10008.1.2.1		
		JPEG Baseline	1.2.840.10008.1.2.4.50		
		JPEG Extended (2 & 4)	1.2.840.10008.1.2.4.51		
		JPEG Lossless	1.2.840.10008.1.2.4.70		
		Non-Hierarchical			

Waveform Storage	1.2.840.10008.5.1.4.1.1.9.1.1;	Implicit VR Little Endian	1.2.840.10008.1.2	SCU	None
SOP classes	1.2.840.10008.5.1.4.1.1.9.1.2;	Explicit VR Big Endian	1.2.840.10008.1.2.2		
	1.2.840.10008.5.1.4.1.1.9.1.3;	Explicit VR Little Endian	1.2.840.10008.1.2.1		
	1.2.840.10008.5.1.4.1.1.9.2.1;				
	1.2.840.10008.5.1.4.1.1.9.3.1;				
	1.2.840.10008.5.1.4.1.1.9.4.1				
Digital X-Ray	1.2.840.10008.5.1.4.1.1.1.1.1	Implicit VR Little Endian	1.2.840.10008.1.2	SCU	None
Image Storage	1.2.840.10008.5.1.4.1.1.1.1	Explicit VR Big Endian	1.2.840.10008.1.2.2		
SOP class		Explicit VR Little Endian	1.2.840.10008.1.2.1		
		JPEG Baseline	1.2.840.10008.1.2.4.50		
		JPEG Extended (2 & 4)	1.2.840.10008.1.2.4.51		
		JPEG Lossless	1.2.840.10008.1.2.4.70		
		Non-Hierarchical			
Digital	1.2.840.10008.5.1.4.1.1.1.2.1	Implicit VR Little Endian	1.2.840.10008.1.2	SCU	None
Mammography	1.2.840.10008.5.1.4.1.1.1.2	Explicit VR Big Endian	1.2.840.10008.1.2.2		
X-Ray Image		Explicit VR Little Endian	1.2.840.10008.1.2.1		
Storage SOP		JPEG Baseline	1.2.840.10008.1.2.4.50		
Class		JPEG Extended (2 & 4)	1.2.840.10008.1.2.4.51		
		JPEG Lossless	1.2.840.10008.1.2.4.70		
		Non-Hierarchical			
Standard RT	1.2.840.10008.5.1.4.1.1.481.3	Implicit VR Little Endian	1.2.840.10008.1.2	SCU	None
Structure set		Explicit VR Big Endian	1.2.840.10008.1.2.2		
Storage SOP		Explicit VR Little Endian	1.2.840.10008.1.2.1		
class					
CSA Non-Image	1.3.12.2.1107.5.9.1	Implicit VR Little Endian	1.2.840.10008.1.2	SCU	None
Storage		Explicit VR Big Endian	1.2.840.10008.1.2.2		
SOP class		Explicit VR Little Endian	1.2.840.10008.1.2.1		

Not all the listed transfer syntaxes will be proposed all the time. For some abstract syntaxes only a list of uncompressed (UC) transfer syntaxes (one or more) will be proposed, for other abstract syntaxes also JPEG Lossless (LL) syntax will be proposed and/or a list of JPEG Lossy (LY) transfer syntaxes. The contents of this lists is configurable, e.g. UC could be configured to contain only Implicit Little Endian for instance.

Depending on the real world activity initiating the C-STORE, we have the following behaviours:

- ❑ If the C-STORE is initiated by a user, a configuration parameter called QualityFactor(Q) will be used to decide which transfer syntax lists will be proposed. Q can take values between 0 and 100. If Q=0, only UC will be proposed. If Q = 100, UC and LL will be proposed. Else UN and LY will be proposed.
- ❑ If the C-STORE is initiated by the C-MOVE SCP, there is another configuration parameter called Compression Types Supported (CTS) which will be used to decide what transfer syntaxes are proposed. CTS can take values between 0 and 2. If CTS=0, only UC will be proposed. If CTS=1, UC and LY will be proposed. Else UC and LL will be proposed.

It is not possible to send an image that is locally stored in a Lossy compressed format using an uncompressed or lossless transfer syntax.

SOP Specific Conformance Statement - Storage SCU

The DICOM images created by Somaris/5 DICOM application conform to the DICOM IOD definitions (Standard Extended IODs). But they will contain additional private elements which have to be discarded by a DICOM system when modifying the image.

The DICOM nodes are responsible for data consistency when modifying images. All unknown private attributes have to be removed upon modification!

Somaris/5 does not change private attributes if no modification is done. But during a *Save as* operation all non *syngo* defined private attributes will be removed. For association and DIMSE level time outs refer

→ page A.5–2, *Configurable Parameters*

Image Pixel Attribute Description for Grayscale Images

The Somaris/5 DICOM application supports the MONOCHROME1 and MONOCHROME2 photometric interpretation pixel format and graphic overlay with unsigned integer and 8 or 16 bits allocated. Possible values:

Pixel plane

- samples per pixel (attribute 0028, 0002) = 1
- photometric interpretation (attribute 0028,0004) = "MONOCHROME1"
- photometric interpretation (attribute 0028,0004) = "MONOCHROME2"
- pixel representation (attribute 0028, 0103) = 0
- bits allocated (attribute 0028, 0100) = 8, 16
- bits stored (attribute 0028,0101) = 8, 10, 12
- high bit (attribute 0028,0102) = 7, 9, 11

Overlay plane

- overlay type (attribute 60xx, 0040) = "G"
- overlay bits allocated (attribute 60xx, 0100) = 16
- overlay bit position (attribute 60xx, 0102) = 12, 13, 14, 15

Overlay plane

- overlay type (attribute 60xx, 0040) = "G"
- overlay bits allocated (attribute 60xx, 0100) = 1
- overlay bit position (attribute 60xx, 0102) = 0
- overlay data (attribute 60xx, 3000) = supported

The Somaris/5 DICOM application sends also the MONOCHROME1 and MONOCHROME2 photometric interpretation pixel format with binary 2's complement integer and 16 bits allocated. Possible values:

Pixel plane

- samples per pixel (attribute 0028, 0002) = 1
- photometric interpretation (attribute 0028,0004) = "MONOCHROME1"
- photometric interpretation (attribute 0028,0004) = "MONOCHROME2"
- pixel representation (attribute 0028, 0103) = 1
- bits allocated (attribute 0028, 0100) = 16
- bits stored (attribute 0028,0101) = 16
- high bit (attribute 0028,0102) = 15

Overlay plane

- overlay type (attribute 60xx, 0040) = "G"
- overlay bits allocated (attribute 60xx, 0100) = 1
- overlay bit position (attribute 60xx, 0102) = 0
- overlay data (attribute 60xx, 3000) = supported

Image Pixel Attribute Description for Color Images

The Somaris/5 DICOM application supports the RGB color image description with the unsigned integer 24 bit color image plane pixel format:

- samples per pixel (attribute 0028, 0002) = 3
- photometric interpretation (attribute 0028,0004) = “RGB”
- pixel representation (attribute 0028, 0103) = 0
- bits allocated (attribute 0028, 0100) = 8
- bits stored (attribute 0028,0101) = 8
- high bit (attribute 0028,0102) = 7
- planar configuration (attribute 0028,0006) = 0

Note

The Somaris/5 DICOM application extends the CT Image IOD to support RGB pixel format as described above.
→ page A.4–1, *Standard Extensions*

The Somaris/5 DICOM application supports the “Palette Color” color image description with unsigned integer and 2’s complement pixel format:

- samples per pixel (attribute 0028, 0002) = 1
- photometric interpretation (attribute 0028,0004) = “PALETTE COLOR”
- pixel representation (attribute 0028, 0103) = 0
- bits allocated (attribute 0028, 0100) = 8, 16
- bits stored (attribute 0028,0101) = 8, 16
- high bit (attribute 0028,0102) = 7, 15

Both 8bit and 16bit palettes are supported - but no Segmented Palette Color LUTs.

Association Acceptance Policy

The Somaris/5 DICOM application attempts to accept a new association for

- DIMSE C-ECHO
- DIMSE C-STORE

service operations.

Real-World Activity - Storage SCP

Associated Real-World Activity - Storage SCP

The daemon receiving process will accept an association and will receive any images transmitted on that association and will store the images on disk in the own database.

Proposed Presentation Contexts - Storage SCP

The Somaris/5 DICOM application will propose Presentation Contexts as shown in the following table:

Presentation Context Table

Abstract Syntax		Transfer Syntax		Role	Extended Negotiation
Name	UID	Name List	UID List		
CR Image Storage SOP class	1.2.840.10008.5.1.4.1.1.1	Implicit VR Little Endian	1.2.840.10008.1.2	SCP	None
		Explicit VR Big Endian	1.2.840.10008.1.2.2		
		Explicit VR Little Endian	1.2.840.10008.1.2.1		
		JPEG Baseline	1.2.840.10008.1.2.4.50		
		JPEG Extended (2 & 4)	1.2.840.10008.1.2.4.51		
		JPEG Lossless	1.2.840.10008.1.2.4.70		
		Non-Hierarchical			
CT Image Storage SOP class	1.2.840.10008.5.1.4.1.1.2	Implicit VR Little Endian	1.2.840.10008.1.2	SCP	None
		Explicit VR Big Endian	1.2.840.10008.1.2.2		
		Explicit VR Little Endian	1.2.840.10008.1.2.1		
		JPEG Baseline	1.2.840.10008.1.2.4.50		
		JPEG Extended (2 & 4)	1.2.840.10008.1.2.4.51		
		JPEG Lossless	1.2.840.10008.1.2.4.70		
		Non-Hierarchical			



MR Image Storage SOP class	1.2.840.10008.5.1.4.1.1.4	Implicit VR Little Endian	1.2.840.10008.1.2	SCP	None
		Explicit VR Big Endian	1.2.840.10008.1.2.2		
		Explicit VR Little Endian	1.2.840.10008.1.2.1		
		JPEG Baseline	1.2.840.10008.1.2.4.50		
		JPEG Extended (2 & 4)	1.2.840.10008.1.2.4.51		
		JPEG Lossless	1.2.840.10008.1.2.4.70		
		Non-Hierarchical			
NM Image Storage SOP class	1.2.840.10008.5.1.4.1.1.20	Implicit VR Little Endian	1.2.840.10008.1.2	SCP	None
		Explicit VR Big Endian	1.2.840.10008.1.2.2		
		Explicit VR Little Endian	1.2.840.10008.1.2.1		
		JPEG Baseline	1.2.840.10008.1.2.4.50		
		JPEG Extended (2 & 4)	1.2.840.10008.1.2.4.51		
		JPEG Lossless	1.2.840.10008.1.2.4.70		
		Non-Hierarchical			
SC Image Storage SOP class	1.2.840.10008.5.1.4.1.1.7	Implicit VR Little Endian	1.2.840.10008.1.2	SCP	None
		Explicit VR Big Endian	1.2.840.10008.1.2.2		
		Explicit VR Little Endian	1.2.840.10008.1.2.1		
		JPEG Baseline	1.2.840.10008.1.2.4.50		
		JPEG Extended (2 & 4)	1.2.840.10008.1.2.4.51		
		JPEG Lossless	1.2.840.10008.1.2.4.70		
		Non-Hierarchical			
XA Image Storage SOP class	1.2.840.10008.5.1.4.1.1.12.1	Implicit VR Little Endian	1.2.840.10008.1.2	SCP	None
		Explicit VR Big Endian	1.2.840.10008.1.2.2		
		Explicit VR Little Endian	1.2.840.10008.1.2.1		
		JPEG Baseline	1.2.840.10008.1.2.4.50		
		JPEG Extended (2 & 4)	1.2.840.10008.1.2.4.51		
		JPEG Lossless	1.2.840.10008.1.2.4.70		
		Non-Hierarchical			
XA Bi-Plane Image Storage SOP class (Retired)	1.2.840.10008.5.1.4.1.1.12.3	Implicit VR Little Endian	1.2.840.10008.1.2	SCP	None
		Explicit VR Big Endian	1.2.840.10008.1.2.2		
		Explicit VR Little Endian	1.2.840.10008.1.2.1		
		JPEG Baseline	1.2.840.10008.1.2.4.50		
		JPEG Extended (2 & 4)	1.2.840.10008.1.2.4.51		
		JPEG Lossless	1.2.840.10008.1.2.4.70		
		Non-Hierarchical			



XRF Image Storage SOP class	1.2.840.10008.5.1.4.1.1.12.2	Implicit VR Little Endian	1.2.840.10008.1.2	SCP	None
		Explicit VR Big Endian	1.2.840.10008.1.2.2		
		Explicit VR Little Endian	1.2.840.10008.1.2.1		
		JPEG Baseline	1.2.840.10008.1.2.4.50		
		JPEG Extended (2 & 4)	1.2.840.10008.1.2.4.51		
		JPEG Lossless	1.2.840.10008.1.2.4.70		
		Non-Hierarchical			
US MF Image Storage SOP class	1.2.840.10008.5.1.4.1.1.13.1	Implicit VR Little Endian	1.2.840.10008.1.2	SCP	None
		Explicit VR Big Endian	1.2.840.10008.1.2.2		
		Explicit VR Little Endian	1.2.840.10008.1.2.1		
		JPEG Baseline	1.2.840.10008.1.2.4.50		
		JPEG Extended (2 & 4)	1.2.840.10008.1.2.4.51		
		JPEG Lossless	1.2.840.10008.1.2.4.70		
		Non-Hierarchical			
US Image Storage SOP class	1.2.840.10008.5.1.4.1.1.16.1	Implicit VR Little Endian	1.2.840.10008.1.2	SCP	None
		Explicit VR Big Endian	1.2.840.10008.1.2.2		
		Explicit VR Little Endian	1.2.840.10008.1.2.1		
		JPEG Baseline	1.2.840.10008.1.2.4.50		
		JPEG Extended (2 & 4)	1.2.840.10008.1.2.4.51		
		JPEG Lossless	1.2.840.10008.1.2.4.70		
		Non-Hierarchical			
PET Image Storage SOP class	1.2.840.10008.5.1.4.1.1.128	Implicit VR Little Endian	1.2.840.10008.1.2	SCP	None
		Explicit VR Big Endian	1.2.840.10008.1.2.2		
		Explicit VR Little Endian	1.2.840.10008.1.2.1		
		JPEG Baseline	1.2.840.10008.1.2.4.50		
		JPEG Extended (2 & 4)	1.2.840.10008.1.2.4.51		
		JPEG Lossless	1.2.840.10008.1.2.4.70		
		Non-Hierarchical			
Waveform Storage SOP classes	1.2.840.10008.5.1.4.1.1.9.1.1; 1.2.840.10008.5.1.4.1.1.9.1.2; 1.2.840.10008.5.1.4.1.1.9.1.3; 1.2.840.10008.5.1.4.1.1.9.2.1; 1.2.840.10008.5.1.4.1.1.9.3.1; 1.2.840.10008.5.1.4.1.1.9.4.1	Implicit VR Little Endian	1.2.840.10008.1.2	SCP	None
		Explicit VR Big Endian	1.2.840.10008.1.2.2		
		Explicit VR Little Endian	1.2.840.10008.1.2.1		
		JPEG Baseline	1.2.840.10008.1.2.4.50		
		JPEG Extended (2 & 4)	1.2.840.10008.1.2.4.51		
		JPEG Lossless	1.2.840.10008.1.2.4.70		

CSA Non-Image	1.3.12.2.1107.5.9.1	Implicit VR Little Endian	1.2.840.10008.1.2	SCP	None
Storage		Explicit VR Big Endian	1.2.840.10008.1.2.2		
SOP class		Explicit VR Little Endian	1.2.840.10008.1.2.1		
Digital	1.2.840.10008.5.1.4.1.1.1.1	Implicit VR Little Endian	1.2.840.10008.1.2	SCP	None
X-Ray Image	1.2.840.10008.5.1.4.1.1.1.1	Explicit VR Big Endian	1.2.840.10008.1.2.2		
Storage		Explicit VR Little Endian	1.2.840.10008.1.2.1		
SOP class		JPEG Baseline	1.2.840.10008.1.2.4.50		
		JPEG Extended (2 & 4)	1.2.840.10008.1.2.4.51		
		JPEG Lossless	1.2.840.10008.1.2.4.70		
		Non-hierarchical			
Digital	1.2.840.10008.5.1.4.1.1.1.2.1	Implicit VR Little Endian	1.2.840.10008.1.2	SCP	None
Mammography	1.2.840.10008.5.1.4.1.1.1.2	Explicit VR Big Endian	1.2.840.10008.1.2.2		
X-Ray Image		Explicit VR Little Endian	1.2.840.10008.1.2.1		
Storage		JPEG Baseline	1.2.840.10008.1.2.4.50		
SOP class		JPEG Extended (2 & 4)	1.2.840.10008.1.2.4.51		
		JPEG Lossless	1.2.840.10008.1.2.4.70		
		Non-hierarchical			
Standard RT	1.2.840.10008.5.1.4.1.1.481.3	Implicit VR Little Endian	1.2.840.10008.1.2	SCP	None
Structure set		Explicit VR Big Endian	1.2.840.10008.1.2.2		
Storage		Explicit VR Little Endian	1.2.840.10008.1.2.1		
SOP class					
Verification	1.2.840.10008.1.1	Implicit VR Little Endian	1.2.840.10008.1.2	SCP	None
		Explicit VR Big Endian	1.2.840.10008.1.2.2		
		Explicit VR Little Endian	1.2.840.10008.1.2.1		

SOP Specific Conformance Statement - Storage SCP

The Somaris/5 DICOM application conforms to the Full Storage Service Class at Level 2 - with the exception that private Sequences (private elements with VR=SQ) are not supported in Explicit VR Transfer syntax and will be ignored. When private Sequences are received in implicit VR then the whole sequence is stored as one binary element of VR=OW.

In the event of a successful C-STORE operation, the image has successfully been written on disk in the Siemens CSA image format.

The DICOM receiver returns the status Success upon successful operation otherwise one of the following status codes is returned and the association aborted:

Refused (A700):

This error status indicates a lack of Resources (e.g. not enough disk space) on the Somaris/5 modality.

Error (A900 or C000):

An error occurred while processing the image which makes it impossible to proceed. The image will not be stored and the association aborted.

If an image with the same SOP Instance UID (as that image being received) is already present in the database then the received image will be ignored. So if a remote node sends twice the same image (same SOP Instance UID) then there will still be only one image (the first) in the database of the DICOM receiver.

The Somaris/5 DICOM receiver can receive all kinds of different image formats. But for Display of such images the following restrictions apply:

Image Pixel Attribute Acceptance Criterion for Grayscale Images

The Display application accepts the MONOCHROME1 and MONOCHROME2 photometric interpretation pixel format and graphic overlay with unsigned integer and 8 or 16 bits allocated. Accepted values:

Pixel plane

- samples per pixel (attribute 0028, 0002) = 1
- photometric interpretation (attribute 0028,0004) = "MONOCHROME1"
- photometric interpretation (attribute 0028,0004) = "MONOCHROME2"
- pixel representation (attribute 0028, 0103) = 0 (unsigned)
- bits allocated (attribute 0028, 0100) = 8, 16
- bits stored (attribute 0028,0101) = 8, 10, 12
- high bit (attribute 0028,0102) = bits stored - 1
- only aspect ratio (attribute 0028,0034) 1:1 is allowed

Overlay plane

- overlay type (attribute 60xx, 0040) = "G"
- overlay bits allocated (attribute 60xx, 0100) = 16
- overlay bit position (attribute 60xx, 0102) = 12, 13, 14, 15
(only bits above high bit are allowed)

Overlay plane

- overlay type (attribute 60xx, 0040) = "G"
- overlay bits allocated (attribute 60xx, 0100) = 1
- overlay bit position (attribute 60xx, 0102) = 0
- overlay data (attribute 60xx, 3000) = supported

The Somaris/5 DICOM application accepts also the MONOCHROME1 and MONOCHROME2 photometric interpretation pixel format with binary 2's complement integer and 16 bits allocated. Accepted values:

Pixel plane

- samples per pixel (attribute 0028, 0002) = 1
- photometric interpretation (attribute 0028,0004) = "MONOCHROME1"
- photometric interpretation (attribute 0028,0004) = "MONOCHROME2"
- pixel representation (attribute 0028, 0103) = 1 (signed)
- bits allocated (attribute 0028, 0100) = 16
- bits stored (attribute 0028,0101) = 16
- high bit (attribute 0028,0102) = 15
- only aspect ratio (attribute 0028,0034) 1:1 is allowed

Overlay plane

- overlay type (attribute 60xx, 0040) = "G"
- overlay bits allocated (attribute 60xx, 0100) = 1
- overlay bit position (attribute 60xx, 0102) = 0
- overlay data (attribute 60xx, 3000) = supported

For MOD LUT both the linear LUT (Rescale Slope/Intercept) and the MOD LUT SQ are supported and considered when pixel data is displayed. However the following limitations apply:

- The MOD LUT SQ will be ignored for 8 bit signed pixels.
- The pixel format is not changed by applying the MOD LUT SQ, even if the output range of the LUT is larger than the input range.(e.g. 8 bit -> 16 bit).
- If the MOD LUT SQ contains multiple LUTs then only the first one is used.

For VOI LUT also both the linear LUT (Window Center/Width) and the VOI LUT SQ are supported (VOI LUT SQ with 8 or 16 bit LUT data).

In this version the Display application supports only rectangular and circular Shutters, one of each per image. Images with other shutter types will be displayed without Shutter.

Image Pixel Attribute Acceptance Criterion for Color Images

The Siemens Display application supports the RGB color image description with the unsigned integer 24 bit color image plane pixel format. Accepted values:

- samples per pixel (attribute 0028, 0002) = 3
- photometric interpretation (attribute 0028,0004) = "RGB"
- pixel representation (attribute 0028, 0103) = 0
- bits allocated (attribute 0028, 0100) = 8
- bits stored (attribute 0028,0101) = 8
- high bit (attribute 0028,0102) = 7
- planar configuration (attribute 0028,0006) = 0 (pixel interleave)
- Only aspect ratio (attribute 0028,0034) 1:1 is allowed for Pixel Aspect Ratio, and Pixel Spacing must be the same for both directions.

The Somaris/5 DICOM application supports the "Palette Color" color image description with unsigned integer and 2's complement pixel format:

- samples per pixel (attribute 0028, 0002) = 1
- photometric interpretation (attribute 0028,0004) = "PALETTE COLOR"
- pixel representation (attribute 0028, 0103) = 0
- bits allocated (attribute 0028, 0100) = 8, 16
- bits allocated (attribute 0028, 0100) = 8 and bits stored (attribute 0028,0101) = 8
- bits allocated (attribute 0028, 0100) = 16 and bits stored (attribute 0028,0101) = 16
- high bit (attribute 0028,0102) = 7, 15

Both 8bit and 16bit palettes are supported - but no Segmented Palette Color LUTs.

**Presentation Context
Acceptance Criterion -
Storage SCP**

The Somaris/5 DICOM application will accept any number of Verification or storage SOP classes that are listed above. In the event that the Siemens Somaris/5 DICOM application runs out of resources, it will reject the association request.

**Transfer Syntax Selection
Policies - Storage SCP**

The Somaris/5 DICOM application supports

- ⇒ the Implicit VR Little Endian, the Explicit VR Little Endian and Explicit VR Big Endian transfer syntaxes
- ⇒ the JPEG Baseline and JPEG Extended transfer syntaxes (JPEG lossy)
- ⇒ the JPEG lossless Non-Hierarchical transfer syntax

Any proposed presentation context which includes one of these transfer syntaxes will be accepted. Any proposed presentation context that does not include one of these transfer syntaxes will be rejected.

The order of preference in accepting a Transfer syntax is:

1. JPEG Extended Process 2 And 4
2. JPEG Lossless Non-hierarchical
3. JPEG Baseline
4. Explicit VR Little Endian
5. Explicit VR Big Endian
6. Implicit VR Little Endian

Storage Commitment AE Specification

The Somaris/5 Storage Commitment AE provide Standard Conformance to the following DICOM V3.0 SOP Classes both as SCU and as SCP.

SOP Class Name	SOP Class UID
Storage Commitment Push Model	1.2.840.10008.1.20.1

Association Establishment Policies

General

The configuration of the Somaris/5 Storage Commitment AE defines the Application Entity Titles, the port numbers and of course the host name and net address.

Number of Associations

The Somaris/5 Storage Commitment AE initiates several association at a time, one for each storage commitment request being processed.

Asynchronous Nature

The Somaris/5 Storage Commitment AE does not support asynchronous communication (multiple outstanding transactions over a single association).

Implementation Identifying Information

The Somaris/5 Storage Commitment AE provides the Implementation Class UID of

❑ "1.3.12.2.1107.5.1.4"

and an Implementation Version Name of

❑ "SIEMENS_S5VA45C".

Association Initiation Policy

The Somaris/5 Storage Commitment AE initiates an association in two cases: when acting as SCU, in order to send a request for storage commitment and when acting as SCP and the association on which the storage commitment request was received is not open anymore.

Real-World Activity - Send Storage Commitment Request

Associated Real-World Activity - Send Storage Commitment Request

The user has sent (or archived) images to another DICOM node, which is configured as storage commitment SCP. Somaris/5 will automatically attempt to send a storage commitment request for this images.

Proposed Presentation Contexts - Send Storage Commitment Request

The Somaris/5 Storage Commitment AE will propose Presentation Contexts as shown in the following table:

Presentation Context Table

Abstract Syntax		Transfer Syntax		Role	Extended
Name	UID	Name List	UID List		Negotiation
Storage	1.2.840.10008.1.20.1	Implicit VR Little Endian	1.2.840.10008.1.2	SCU	None
Commitment Push		Explicit VR Big Endian	1.2.840.10008.1.2.2		
Model SOP Class		Explicit VR Little Endian	1.2.840.10008.1.2.1		

SOP Specific Conformance Statement - Send Storage Commitment Request

The SCU sends the N-ACTION-RQ message and waits for the N-ACTION-RSP. After receiving this, the transaction is marked as “waiting”.

Depending on a configuration value, the association will be closed or kept open. In the first case, there is another configurable value giving the number of minutes (by default 60) to wait for the corresponding N_EVENT_REPORT. In the second case, this time is the (also configurable) time-out for the association. For both cases, if the N_EVENT_REPORT does not arrive during the configured time, the transaction will be marked as failed.

If the N_EVENT_REPORT received has the status of "complete - failure exists", the transaction is marked as failed, else the transaction is marked as "completed"; In both cases, a message is shown to the user.

Storage Commitment is supported for all the SOP class UIDs as mentioned in table → page A.2–13.

The Referenced Study Component Sequence is not supported.

Storage Media File-Set ID and UID Attributes will not be supported in the N-ACTION primitive invoked by the Storage Commitment SCU.

Association Acceptance Policy

The Somaris/5 Storage Commitment AE accepts an association in this case: when acting as SCU if configured to receive N-EVENT-REPORT on a separate association.

Real World Activity - Receive Storage Commitment Response

Associated Real World Activity - Receive Storage Commitment Response

The Somaris/5 Storage Commitment AE has sent a Storage Commitment Request and, being configured to receive response on a separate association, has closed the association, and now it gets an association request from the Storage Commitment SCP that want to send the results.

Accepted Presentation Contexts - Receive Storage Commitment Response

The Somaris/5 Storage Commitment AE will accept Presentation Contexts as shown in the following table:

Presentation Context Table

Abstract Syntax		Transfer Syntax		Role	Extended
Name	UID	Name List	UID List		Negotiation
Storage	1.2.840.10008.1.20.1	Implicit VR Little Endian	1.2.840.10008.1.2	SCU	None
Commitment Push		Explicit VR Big Endian	1.2.840.10008.1.2.2		
Model SOP class		Explicit VR Little Endian	1.2.840.10008.1.2.1		

SOP Specific Conformance Statement - Receive Storage Commitment Response

If the N_EVENT_REPORT received has the status of "complete - failure exists", the transaction is marked as failed, else the transaction is marked as "completed"; In both cases, a message is shown to the user.

Query/Retrieve AE Specification

The Query/Retrieve SCU request that the remote SCP perform a match of all keys specified in the request, against the information in its database and the identified images will be moved or retrieved to the same or a different storage association.

The Query/Retrieve SCP responds to queries based on the records based on its database and images will be send to the requesting SCU or to a different storage destination.

Somaris/5 DICOM application provides Standard Conformance to the following DICOM V3.0 SOP Classes as SCU and SCP:

SOP Class Name	SOP Class UID
Patient Root Query/Retrieve Information Model - FIND	1.2.840.10008.5.1.4.1.2.1.1
Patient Root Query/Retrieve Information Model - MOVE	1.2.840.10008.5.1.4.1.2.1.2
Study Root Query/Retrieve Information Model - FIND	1.2.840.10008.5.1.4.1.2.2.1
Study Root Query/Retrieve Information Model - MOVE	1.2.840.10008.5.1.4.1.2.2.2

Somaris/5 DICOM implementation provides Standard Conformance to the following DICOM V3.0 SOP Classes as an SCP:

SOP Class Name	SOP Class UID
Patient Root Query/Retrieve Information Model - FIND	1.2.840.10008.5.1.4.1.2.1.1
Patient Root Query/Retrieve Information Model - MOVE	1.2.840.10008.5.1.4.1.2.1.2



SOP Class Name	SOP Class UID
Patient Root Query/Retrieve Information Model - GET	1.2.840.10008.5.1.4.1.2.1.3
Study Root Query/Retrieve Information Model - FIND	1.2.840.10008.5.1.4.1.2.2.1
Study Root Query/Retrieve Information Model - MOVE	1.2.840.10008.5.1.4.1.2.2.2
Study Root Query/Retrieve Information Model - GET	1.2.840.10008.5.1.4.1.2.2.3
Patient/Study Only Query/Retrieve Information Model - FIND	1.2.840.10008.5.1.4.1.2.3.1
Patient/Study Only Query/Retrieve Information Model - MOVE	1.2.840.10008.5.1.4.1.2.3.2
Patient/Study Only Query/Retrieve Information Model - GET	1.2.840.10008.5.1.4.1.2.3.3

Note

For the DICOM Retrieve SOP class C-MOVE and C-GET please see → page A.2–13, *Association Acceptance Policy* for more information about supported DICOM IODs and Presentation contexts supported by the Siemens Storage SCP.

Association Establishment Policies

General

The configuration of the Somaris/5 DICOM Query/Retrieve application defines the Application Entity Titles, the port numbers and of course the host name and net address.

Number of Associations

The Somaris/5 DICOM Query/Retrieve AE initiates several association at a time, one for each query/retrieve request being processed.

Asynchronous Nature

The Somaris/5 DICOM Query/Retrieve AE does not support asynchronous communication (multiple outstanding transactions over a single association).

Implementation Identifying Information

The Somaris/5 DICOM Query/Retrieve AE provides the Implementation Class UID of

❑ "1.3.12.2.1107.5.1.4"

and an Implementation Version Name of

❑ "SIEMENS_S5VA45C".

Association Initiation Policy

The Query/Retrieve SCU and SCP establish an association by using the DICOM association services. During association establishment the Query/Retrieve application entities negotiate the supported SOP classes to exchange the capabilities of the SCU and the SCP.

The following DIMSE-C operations are supported as SCU:

- C-FIND
- C-MOVE

Real-World Activity - Find SCU

The associated Real-World activity is to initiate query request to an SCP with the query models Patient Root and Study Root.

**Associated Real-World
Activity - Find SCU**

Proposed Presentation Contexts - Find SCU

The Somaris/5 DICOM Query application will propose Presentation Contexts as shown in the following table:

Presentation Context Table					
Abstract Syntax		Transfer Syntax		Role	Extended
Name	UID	Name List	UID List		Negotiation
Patient Root Query/Retrieve Find	1.2.840.10008.5.1.4.1.2.1.1	DICOM Implicit VR Little Endian Transfer Syntax	1.2.840.10008.1.2	SCU	See Note
		DICOM Explicit VR Little Endian Transfer Syntax	1.2.840.10008.1.2.1		
		DICOM Explicit VR Big Endian Transfer Syntax	1.2.840.10008.1.2.2		
Study Root Query/Retrieve Find	1.2.840.10008.5.1.4.1.2.2.1	DICOM Implicit VR Little Endian Transfer Syntax	1.2.840.10008.1.2	SCU	See Note
		DICOM Explicit VR Little Endian Transfer Syntax	1.2.840.10008.1.2.1		
		DICOM Explicit VR Big Endian Transfer Syntax	1.2.840.10008.1.2.2		

It is configurable which of the two query models (or both) are to be used by the Siemens Query SCU application.

Note

C-FIND Extended Negotiation is NOT supported by the SCU.

SOP Specific Conformance Statement - Find SCU

The Somaris/5 DICOM Query/Retrieve SCU supports hierarchical queries with all mandatory search keys. On each level, the unique attributes of all previous levels are also sent (values are provided by the user by selection from a list). For instance for a query using the patient root model on Series level, the Patient ID of the current selected patient and the Study Instance UID of the current selected study are included in the message.

The following table *Query attributes* describes the search keys for the two query models (Patient Root and Study Root) that the Somaris/5 Query / Retrieve application supports as an SCU. Matchings are either wildcard, which means that the user can supply a string containing wildcards, either universal, which means that the attribute is returned no matter what value it has.

Attribute name	Tag	Type	Matching	user input	return value displayed
Patient level^a					
Patient name	(0010,0010)	R	wildcard ^C	enter value	yes
Patient ID	(0010,0020)	U	wildcard ^C	enter value	yes
Patient's birth date	(0010,0030)	O	universal (NULL)	-	yes
Patient's sex	(0010,0040)	O	universal (NULL)	-	yes
Number of Patient related studies	(0020,1200)	O	universal (NULL)	-	yes
Number of Patient relates series	(0020,1202)	O	universal (NULL)	-	yes
Number of Patient related instances	(0020,1204)	O	universal (NULL)	-	yes

Attribute name	Tag	Type	Matching	user input	return value displayed
Study level					
Patient name ^b	(0010,0010)	R	wildcard ^c	enter value	yes
Patient ID ^b	(0010,0020)	R	wildcard ^c	enter value	yes
Study instance UID	(0020,000D)	U	single value	select from list	-
Study ID	(0020,0010)	R	universal (NULL)	-	-
Study date	(0008,0020)	R	universal (NULL)	-	yes
Study time	(0008,0030)	R	universal (NULL)	-	yes
Accession number	(0008,0050)	R	universal (NULL)	-	yes
Study description	(0008,1030)	O	universal (NULL)	-	yes
Referring physician's name	(0008,0090)	O	universal (NULL)	-	yes
Name of physician reading study	(0008,8060)	O	universal (NULL)	-	yes
Modalities in Study	(0008,0061)	O	universal (NULL)	-	yes
Storage Media File Set ID	(0008,0130)	O	universal (NULL)	-	yes
Retrieve AE Title	(0008,0054)	O	universal (NULL)	-	yes
Number of study related series	(0020,1206)	O	universal (NULL)	-	yes
Number of study related instances	(0020,1208)	O	universal (NULL)	-	yes



Attribute name	Tag	Type	Matching	user input	return value displayed
Series level					
Series instance UID	(0020,000E)	U	single value	select from list	-
Series number	(0020,0011)	R	universal (NULL)	-	yes
Modality	(0008,0060)	R	universal (NULL)	-	yes
Series date	(0008,0021)	O	universal (NULL)	-	yes
Series time	(0008,0031)	O	universal (NULL)	-	yes
Study ID	(0020,0010)	O	universal (NULL)	-	yes
Series description	(0008,103E)	O	universal (NULL)	-	yes
Storage Media File Set ID	(0008,0130)	O	universal (NULL)	-	yes
Retrieve AE Title	(0008,0054)	O	universal (NULL)	-	yes
Protocol name	(0018,1030)	O	universal (NULL)	-	yes
Performed procedure step start date	(0040,0244)	O	universal (NULL)	-	yes
Performed procedure step start time	(0040,0245)	O	universal (NULL)	-	yes
Number of series related instances	(0020,1209)	O	universal (NULL)	-	yes



Attribute name	Tag	Type	Matching	user input	return value displayed
Image Level					
SOP Instance UID	(0008,0018)	U	single value	-	-
Image Number	(0020,0013)	R	universal (NULL)	-	yes
Storage Media File Set ID	(0008,0130)	O	universal (NULL)	-	yes
Retrieve AE Title	(0008,0054)	O	universal (NULL)	-	yes
Image date	(0008,0023)	O	universal (NULL)	-	yes
Image time	(0008,0033)	O	universal (NULL)	-	yes
Number of Frames	(0028,0008)	O	universal (NULL)	-	yes
Image comments	(0020,4000)	O	universal (NULL)	-	yes

a. : In the Patient Name always a "*" is added

b. : In the Patient ID always a "*" is added

c. Always a "*" is added to the string supplied by the user

The StudyTransfer Find SCU interprets following status codes:

C-FIND response status			
Service Status	Meaning	Protocol Codes	Related Fields
Refused	Out of Resources	A700	(0000,0902)
Failed	Identifier does not match SOP Class	A900	(0000,0901) (0000,0902)
	Unable to process	Cxxx	(0000,0901) (0000,0902)
Cancel	Matching terminated due to Cancel request	FE00	None
Success	Matching is complete - No final Identifier is supplied	0000	None
Pending	Matches are continuing – Current Match is supplied and any Optional Keys were supported in the same manner as Required Keys	FF00	Identifier
	Matches are continuing – Warning that one or more Optional Keys were not supported for existence and/or matching for this identifier	FF01	Identifier

Associated Real-World Activity - Move SCU*Real-World Activity - Move SCU*

The operator uses the Somaris/5 DICOM Query application to enter the query values and then initiates the retrieval of all matching DICOM composite objects (like images) from the remote node.

This will generate retrieval requests to a remote C-MOVE SCP using the C-MOVE operation with the query model Patient Root and Study Root. The Storage Service Class Conformance Statement of the SCP must describe the C-STORE service which is generated by the C-MOVE service.

Proposed Presentation Contexts - Move SCU

The Somaris/5 DICOM application will propose Presentation Contexts as shown in the following table:

Presentation Context Table					
Abstract Syntax		Transfer Syntax		Role	Extended
Name	UID	Name List	UID List		Negotiation
Patient Root Query/Retrieve Move	1.2.840.10008.5.1.4.1.2.1.2	DICOM Implicit VR Little Endian Transfer Syntax	1.2.840.10008.1.2	SCU	See Note
		DICOM Explicit VR Little Endian Transfer Syntax	1.2.840.10008.1.2.1		
		DICOM Explicit VR Big Endian Transfer Syntax	1.2.840.10008.1.2.2		
Study Root Query/ Retrieve Move	1.2.840.10008.5.1.4.1.2.2.2	DICOM Implicit VR Little Endian Transfer Syntax	1.2.840.10008.1.2	SCU	See Note
		DICOM Explicit VR Little Endian Transfer Syntax	1.2.840.10008.1.2.1		
		DICOM Explicit VR Big Endian Transfer Syntax	1.2.840.10008.1.2.2		

Note

C-MOVE Extended Negotiation will be NOT supported by the SCU.

C-MOVE on Patient level is not supported by the application.

SOP Specific Conformance Statement - Move SCU

At association establishment time the C-MOVE presentation context shall be negotiated. The C-STORE sub-operations must be done on a different association to transfer images to another SCP of the Storage Service Class.

The Move SCU interprets following status codes:

C-MOVE response status			
Service Status	Meaning	Protocol Codes	Related Fields
Refused	Out of Resources - Unable to calculate number of matches	A701	(0000,0902)
	Out of Resources - Unable to perform suboperations	A702	(0000,1020) (0000,1021) (0000,1022) (0000,1023)
Failed	Identifier does not match SOP Class	A900	(0000,0901) (0000,0902)
Failed	Unable to process	Cxxx	(0000,0901) (0000,0902)
Cancel	Sub-operations terminated due to Cancel Indication	FE00	(0000,1020) (0000,1021) (0000,1022) (0000,1023)
Warning	Sub-operations Complete - One or more Failures of Warnings	B000	(0000,1020) (0000,1021) (0000,1022) (0000,1023)
Pending	Sub-operations are continuing	FF00	(0000,1020) (0000,1021) (0000,1022) (0000,1023)
Success	Sub-operations Complete - No Failures or Warning	0000	(0000,1020) (0000,1021) (0000,1022) (0000,1023)

Association Acceptance Policy

The Query/Retrieve SCU and SCP establish an association by using the DICOM association services. During association establishment the Query/Retrieve application entities negotiate the supported SOP classes to exchange the capabilities of the SCU and the SCP.

The following DIMSE-C operations are supported as SCP:

- C-FIND
- C-GET
- C-MOVE
- C-FIND-CANCEL
- C-GET-CANCEL
- C-MOVE-CANCEL

The SCP does support multiple C-FIND-requests over the same association, but not multiple C-MOVE requests.

Real-World Activity - Find SCP

The associated Real-World activity is to respond to query requests to an SCU with the query model Patient Root, Study Root and Patient/Study Only.

Associated Real-World Activity - Find SCP

Proposed Presentation Contexts - Find SCP

The Somaris/5 Query/Retrieve AE will propose Presentation Contexts as shown in the following table:

Presentation Context Table					
Abstract Syntax		Transfer Syntax		Role	Extended
Name	UID	Name List	UID List		Negotiation
Patient Root Query/Retrieve Find	1.2.840.10008.5.1.4.1.2.1.1	DICOM Implicit VR Little Endian Transfer Syntax	1.2.840.10008.1.2	SCP	See Note
		DICOM Explicit VR Little Endian Transfer Syntax	1.2.840.10008.1.2.1		
		DICOM Explicit VR Big Endian Transfer Syntax	1.2.840.10008.1.2.2		
Study Root Query/Retrieve Find	1.2.840.10008.5.1.4.1.2.2.1	DICOM Implicit VR Little Endian Transfer Syntax	1.2.840.10008.1.2	SCP	See Note
		DICOM Explicit VR Little Endian Transfer Syntax	1.2.840.10008.1.2.1		
		DICOM Explicit VR Big Endian Transfer Syntax	1.2.840.10008.1.2.2		
Patient/Study Only Query/Retrieve Find	1.2.840.10008.5.1.4.1.2.3.1	DICOM Implicit VR Little Endian Transfer Syntax	1.2.840.10008.1.2	SCP	See Note
		DICOM Explicit VR Little Endian Transfer Syntax	1.2.840.10008.1.2.1		
		DICOM Explicit VR Big Endian Transfer Syntax	1.2.840.10008.1.2.2		



Note
 C-FIND Extended Negotiation will be NOT supported by the SCP.

The order of preference in accepting a Transfer syntax is:

1. Explicit VR Little Endian
2. Explicit VR Big Endian
3. Implicit VR Little Endian

SOP Specific Conformance Statement - Find SCP

The Somaris/5 DICOM Query/Retrieve SCP supports hierarchical queries with all mandatory and optional search keys. The query attributes will be treated Case Sensitive. The supported attributes on the various levels of the three information models are listed in following tables.

Patient Root Information Model

Patient level attributes			
Attribute name	Tag	Type	Matching
Patient name	(0010,0010)	R	single value, wildcard, universal
Patient id	(0010,0020)	U	single value, wildcard, universal
Patient's birth date	(0010,0030)	O	single value, range, universal
Patient's birth time	(0010,0032)	O	single value, range, universal
Patient's sex	(0010,0040)	O	single value, wildcard, universal
Ethnic group	(0010,2160)	O	single value, wildcard, universal



Patient level attributes			
Attribute name	Tag	Type	Matching
Patient comments	(0010,4000)	O	universal
Number of Patient related studies	(0020,1200)	O	universal
Number of Patient relates series	(0020,1202)	O	universal
Number of Patient related instances	(0020,1204)	O	universal

Study level attributes			
Attribute name	Tag	Usage SCU	Matching
Study instance UID	(0020,000D)	U	single value, list of UID
Study id	(0020,0010)	R	single value, wildcard, universal
Study date	(0008,0020)	R	single value, range, universal
Study time	(0008,0030)	R	single value, range, universal
Accession number	(0008,0050)	R	single value, wildcard, universal
Referring physician's name	(0008,0090)	O	single value, wildcard, universal
Study description	(0008,1030)	O	single value, wildcard, universal
Admitting diagnoses description	(0008,1080)	O	single value, wildcard, universal
Patient's age	(0010,1010)	O	single value, wildcard, universal
Patient's size	(0010,1020)	O	single value, universal

Study level attributes			
Attribute name	Tag	Usage SCU	Matching
Patient's weight	(0010,1030)	O	single value, universal
Occupation	(0010,2180)	O	single value, wildcard, universal
Additional patient history	(0010,21B0)	O	universal
Name of physician reading study	(0008,1060)	O	single value, wildcard, universal
Modalities in Study	(0008,0061)	O	multiple values, universal
Number of study related series	(0020,1206)	O	universal
Number of study related instances	(0020,1208)	O	universal

Series level attributes			
Attribute name	Tag	Usage SCU	Matching
Series instance UID	(0020,000E)	U	single value, list of UID
Series number	(0020,0011)	R	single value, wildcard, universal
Modality	(0008,0060)	R	single value, wildcard, universal
Laterality	(0020,0060)	O	single value, wildcard, universal
Body part examined	(0018,0015)	O	single value, wildcard, universal
Patient position	(0018,5100)	O	single value, wildcard, universal



Series level attributes			
Attribute name	Tag	Usage SCU	Matching
Smallest pixel value in series	(0028,0108)	O	single value, universal
Largest pixel value in series	(0028,0109)	O	single value, universal
Protocol name	(0018,1030)	O	single value, wildcard, universal
Series date	(0008,0021)	O	single value, range, universal
Series time	(0008,0031)	O	single value, range, universal
Series description	(0008,103E)	O	single value, wildcard, universal
Operators name	(0008,1070)	O	single value, wildcard, universal
Performing physician's name	(0008,1050)	O	single value, wildcard, universal
Performed procedure step start date	(0040,0244)	O	universal
Performed procedure step start time	(0040,0245)	O	universal
Number of series related instances	(0020,1209)	O	universal

Image level attributes			
Attribute name	Tag	Usage SCU	Matching
SOP instance UID	(0008,0018)	U	single value, list of UID
Image number	(0020,0013)	R	single value, universal



Image level attributes			
Attribute name	Tag	Usage SCU	Matching
Image date	(0008,0023)	0	single value, range, universal
Image time	(0008,0033)	0	single value, range, universal
Modality	(0008,0060)	0	single value, wildcard, universal
Image comments	(0020,4000)	0	universal

Study Root Information Model

Attribute name	Study level attributes		
	Tag	Type	Matching
Patient name	(0010,0010)	R	single value, wildcard, universal
Patient id	(0010,0020)	R	single value, wildcard, universal
Patient's birth date	(0010,0030)	O	single value, range, universal
Patient's birth time	(0010,0032)	O	single value, range, universal
Patient's sex	(0010,0040)	O	single value, wildcard, universal
Patient comments	(0010,4000)	O	wildcard, universal
Number of Patient related studies	(0020,1200)	O	universal
Number of Patient relates series	(0020,1202)	O	universal
Number of Patient related instances	(0020,1204)	O	universal
Study instance UID	(0020,000D)	U	single value, list of UIDs
Study id	(0020,0010)	R	single value, wildcard, universal
Study date	(0008,0020)	R	single value, range, universal
Study time	(0008,0030)	R	single value, range, universal
Accession number	(0008,0050)	R	single value, wildcard, universal
Referring physician's name	(0008,0090)	O	single value, wildcard, universal



Study level attributes			
Attribute name	Tag	Type	Matching
Study description	(0008,1030)	O	single value, wildcard, universal
Admitting diagnoses description	(0008,1080)	O	single value, wildcard, universal
Patient's age	(0010,1010)	O	single value, wildcard, universal
Patient's size	(0010,1020)	O	single value, universal
Patient's weight	(0010,1030)	O	single value, universal
Occupation	(0010,2180)	O	single value, wildcard, universal
Additional patient history	(0010,21B0)	O	wildcard, universal
Name of physician reading study	(0008,1060)	O	single value, wildcard, universal
Modalities in Study	(0008,0061)	O	multiple values, universal
Number of study related series	(0020,1206)	O	universal
Number of study related instances	(0020,1208)	O	universal

Series level attributes			
Attribute name	Tag	Type	Matching
Series instance UID	(0020,000E)	U	single value, list of UID
Series number	(0020,0011)	R	single value, universal



Series level attributes			
Attribute name	Tag	Type	Matching
Modality	(0008,0060)	R	single value, wildcard, universal
Laterality	(0020,0060)	O	single value, wildcard, universal
Body part examined	(0018,0015)	O	single value, wildcard, universal
Patient position	(0018,5100)	O	single value, wildcard, universal
Smallest pixel value in series	(0028,0108)	O	single value, universal
Largest pixel value in series	(0028,0109)	O	single value, universal
Protocol name	(0018,1030)	O	single value, wildcard, universal
Series date	(0008,0021)	O	single value, range, universal
Series time	(0008,0031)	O	single value, range, universal
Series description	(0008,103E)	O	single value, wildcard, universal
Operators name	(0008,1070)	O	single value, wildcard, universal
Performing physician's name	(0008,1050)	O	single value, wildcard, universal
Performed procedure step start date	(0040,0244)	O	universal
Performed procedure step start time	(0040,0245)	O	universal
Number of series related instances	(0020,1209)	O	universal



Image level attributes			
Attribute name	Tag	Type	Matching
SOP instance UID	(0008,0018)	U	single value, list of UID
Image number	(0020,0013)	R	single value, universal
Image date	(0008,0023)	O	single value, range, universal
Image time	(0008,0033)	O	single value, range, universal
Modality	(0008,0060)	O	single value, wildcard, universal
Image comments	(0020,4000)	O	universal

**Patient Study Only
Information Models**

Patient instance level			
Attribute name	Tag	Type	Matching
Patient name	(0010,0010)	R	single value, wildcard, universal
Patient id	(0010,0020)	U	single value, wildcard, universal
Patient's birth date	(0010,0030)	O	single value, range, universal
Patient's birth time	(0010,0032)	O	single value, range, universal
Patient's sex	(0010,0040)	O	single value, wildcard, universal
Ethnic group	(0010,2160)	O	single value, wildcard, universal



Attribute name	Patient instance level		
	Tag	Type	Matching
Patient comments	(0010,4000)	O	wildcard, universal
Number of Patient related studies	(0020,1200)	O	universal
Number of Patient relates series	(0020,1202)	O	universal
Number of Patient related instances	(0020,1204)	O	universal
Study instance UID	(0020,000D)	U	single value, list of UIDs
Study id	(0020,0010)	R	single value, wildcard, universal
Study date	(0008,0020)	R	single value, range, universal
Study time	(0008,0030)	R	single value, range, universal
Accession number	(0008,0050)	R	single value, wildcard, universal
Referring physician's name	(0008,0090)	O	single value, wildcard, universal
Study description	(0008,1030)	O	single value, wildcard, universal
Admitting diagnoses description	(0008,1080)	O	single value, wildcard, universal
Patient's age	(0010,1010)	O	single value, wildcard, universal
Patient's size	(0010,1020)	O	single value, universal
Patient's weight	(0010,1030)	O	single value, universal
Occupation	(0010,2180)	O	single value, wildcard, universal

Patient instance level			
Attribute name	Tag	Type	Matching
Additional patient history	(0010,21B0)	O	wildcard, universal
Name of physician reading study	(0008,1060)	O	single value, wildcard, universal
Modalities in Study	(0008,0061)	O	multiple values, universal
Number of study related series	(0020,1206)	O	universal
Number of study related instances	(0020,1208)	O	universal

Study level attributes			
Attribute name	Tag	Type	Matching
Study instance UID	(0020,000D)	U	single value, list of UIDs
Study id	(0020,0010)	R	single value, wildcard, universal
Study date	(0008,0020)	R	single value, range, universal
Study time	(0008,0030)	R	single value, range, universal
Accession number	(0008,0050)	R	single value, wildcard, universal
Referring physician's name	(0008,0090)	O	single value, wildcard, universal
Study description	(0008,1030)	O	single value, wildcard, universal
Admitting diagnoses description	(0008,1080)	O	single value, wildcard, universal



Study level attributes			
Attribute name	Tag	Type	Matching
Patient's age	(0010,1010)	O	single value, wildcard, universal
Patient's size	(0010,1020)	O	single value, universal
Patient's weight	(0010,1030)	O	single value, universal
Occupation	(0010,2180)	O	single value, wildcard, universal
Additional patient history	(0010,21B0)	O	wildcard, universal
Name of physician reading study	(0008,1060)	O	single value, wildcard, universal
Modalities in Study	(0008,0061)	O	multiple values, universal
Number of study related series	(0020,1206)	O	universal
Number of study related instances	(0020,1208)	O	universal

The query attributes will be treated Case Sensitive.

In DICOM wildcard queries the symbol '?' is treated as '*' by Find SCP.

So a wildcard query with "?abc*" is actually treated as "*abc*"

If the value for the unique key PatientID is not known, it may be returned empty.

The C_FIND_RSP message will contain the following attributes:

- Specific Character Set (0008,0005) (If there is a specific character set in use).
- Query/Retrieve Level (0008,0052) from the C_FIND_RQ.
- Retrieve AE Title (0008,0054) at study, series and image level.
This value is a list of AE titles from which the images can be retrieved. Might be NULL except for the lowest level of the query model (Image level for Patient Root or Study Root and Study level for Patient/Study Only).
- Storage-Media File-set ID (0088,0130) at level study, series and image. If Storage-Media File-set ID is not present a NULL value will be returned.
- attributes requested by C_FIND_RQ and supported by the SCP

Note

On IMAGE level, if the "Image Comments" attribute was present in the C-FIND-RQ and it is not set, it will not be included in the C-FIND-RSP.

Relational queries are not supported.

A remote DICOM AE can cancel the query by sending a C_CANCEL_FIND_RQ message. If the Find SCP receives C_CANCEL_FIND_RQ before it has completed the processing of the matches it stops the database matching process and returns a status of Cancelled to the remote DICOM AE.

The Find SCP returns following status codes:

C-FIND return status			
Service Status	Meaning	Protocol Codes	Related Fields
Refused	Out of Resources	A700	(0000,0902)
Failed	Identifier does not match SOP Class	A900	(0000,0901) (0000,0902)
	Unable to process	C001	(0000,0901) (0000,0902)
Cancel	Matching terminated due to Cancel request	FE00	None
Success	Matching is complete - No final Identifier is supplied	0000	None
Pending	Matches are continuing – Current Match is supplied and any Optional Keys were supported in the same manner as Required Keys	FF00	Identifier
	Matches are continuing – Warning that one or more Optional Keys were not supported for existence and/or matching for this identifier	FF01	Identifier

Real World Activity - Get SCP

Associated Real-World Activity - Get SCP

The associated Real-World activity is initiated from respond to retrieve requests to an SCU. The SCP supports the query model Patient Root, Study Root and Patient/Study Only. The Storage Service Class Conformance Statement describes the C-STORE service which is generated by C-GET service.

Proposed Presentation Contexts - GET SCP

The Somaris/5 DICOM application will propose Presentation Contexts as shown in the following table:

Presentation Context Table

Abstract Syntax		Transfer Syntax		Role	Extended Negotiation
Name	UID	Name List	UID List		
Patient Root Query/Retrieve Get	1.2.840.10008.5.1.4.1.2.1.3	DICOM Implicit VR Little Endian Transfer Syntax	1.2.840.10008.1.2	SCP	See Note
		DICOM Explicit VR Little Endian Transfer Syntax	1.2.840.10008.1.2.1		
		DICOM Explicit VR Big Endian Transfer Syntax	1.2.840.10008.1.2.2		
Study Root Query/Retrieve Get	1.2.840.10008.5.1.4.1.2.2.3	DICOM Implicit VR Little Endian Transfer Syntax	1.2.840.10008.1.2	SCP	See Note
		DICOM Explicit VR Little Endian Transfer Syntax	1.2.840.10008.1.2.1		
		DICOM Explicit VR Big Endian Transfer Syntax	1.2.840.10008.1.2.2		
Patient/Study Only Query/Retrieve Get	1.2.840.10008.5.1.4.1.2.3.3	DICOM Implicit VR Little Endian Transfer Syntax	1.2.840.10008.1.2	SCP	See Note
		DICOM Explicit VR Little Endian Transfer Syntax	1.2.840.10008.1.2.1		
		DICOM Explicit VR Big Endian Transfer Syntax	1.2.840.10008.1.2.2		

Note

C-GET Extended Negotiation will be NOT supported by the SCP.

The order of preference in accepting a Transfer syntax is:

1. Explicit VR Little Endian
2. Explicit VR Big Endian
3. Implicit VR Little Endian

SOP Specific Conformance Statement - Get SCP

At association establishment time the C-GET presentation context must be negotiated along with the C-STORE sub-operations which must be accomplished on the same association as the C-GET operation.

Note

In DICOM wildcard queries the symbol '?' is treated as '*' by Find SCP.
So a wildcard query with "?abc*" is actually treated as "*abc*"

The Get SCP returns following status codes:

C-MOVE return status			
Service Status	Meaning	Protocol Codes	Related Fields
Refused	Out of Resources - Unable to calculate number of matches	A701	(0000,0902)
	Out of Resources - Unable to perform suboperations	A702	(0000,1020) (0000,1021) (0000,1022) (0000,1023)
Failed	Identifier does not match SOP Class	A900	(0000,0901) (0000,0902)
Failed	Unable to process	C001	(0000,0901) (0000,0902)
Cancel	Sub-operations terminated due to Cancel Indication	FE00	(0000,1020) (0000,1021) (0000,1022) (0000,1023)
Warning	Sub-operations Complete - One or more Failures of Warnings	B000	(0000,1020) (0000,1021) (0000,1022) (0000,1023)
Pending	Sub-operations are continuing	FF00	(0000,1020) (0000,1021) (0000,1022) (0000,1023)
Success	Sub-operations Complete - No Failures or Warning	0000	(0000,1020) (0000,1021) (0000,1022) (0000,1023)

Real-World Activity - Move SCP

Associated Real-World Activity - Move SCP

The associated Real-World activity is to respond to retrieve requests to an SCU. The SCP supports the query model Patient Root, Study Root and Patient/Study Only. The Storage Service Class Conformance Statement describes the C-STORE service which is generated by the C-MOVE service.

Proposed Presentation Contexts - Move SCP

The Somaris/5 DICOM application will propose Presentation Contexts as shown in the following table:

Presentation Context Table

Abstract Syntax		Transfer Syntax		Role	Extended Negotiation
Name	UID	Name List	UID List		
Patient Root Query/Retrieve Move	1.2.840.10008.5.1.4.1.2.1.2	DICOM Implicit VR Little Endian Transfer Syntax	1.2.840.10008.1.2	SCP	See Note
		DICOM Explicit VR Little Endian Transfer Syntax	1.2.840.10008.1.2.1		
		DICOM Explicit VR Big Endian Transfer Syntax	1.2.840.10008.1.2.2		
Study Root Query/Retrieve Move	1.2.840.10008.5.1.4.1.2.2.2	DICOM Implicit VR Little Endian Transfer Syntax	1.2.840.10008.1.2	SCP	See Note
		DICOM Explicit VR Little Endian Transfer Syntax	1.2.840.10008.1.2.1		
		DICOM Explicit VR Big Endian Transfer Syntax	1.2.840.10008.1.2.2		
Patient/Study Only Query/Retrieve Move	1.2.840.10008.5.1.4.1.2.3.2	DICOM Implicit VR Little Endian Transfer Syntax	1.2.840.10008.1.2	SCP	See Note
		DICOM Explicit VR Little Endian Transfer Syntax	1.2.840.10008.1.2.1		
		DICOM Explicit VR Big Endian Transfer Syntax	1.2.840.10008.1.2.2		

Note

C-MOVE Extended Negotiation will be NOT supported by the SCP.

The order of preference in accepting a Transfer syntax is:

1. Explicit VR Little Endian
2. Explicit VR Big Endian
3. Implicit VR Little Endian

SOP Specific Conformance Statement - Move SCP

At association establishment time the C-MOVE presentation context shall be negotiated. The C-STORE sub-operations is done on a different association, specified in the C-MOVE request, to transfer images to another SCP of the Storage Service Class.

Note

In DICOM wildcard queries the symbol '?' is treated as '*' by Find SCP.
So a wildcard query with "?abc*" is actually treated as "*abc*"

The Move SCP returns following status codes:

C-MOVE return status			
Service Status	Meaning	Protocol Codes	Related Fields
Refused	Out of Resources - Unable to calculate number of matches	A701	(0000,0902)
	Out of Resources - Unable to perform suboperations	A702	(0000,1020) (0000,1021) (0000,1022) (0000,1023)
Failed	Identifier does not match SOP Class	A900	(0000,0901) (0000,0902)
Failed	Unable to process	C001	(0000,0901) (0000,0902)
Cancel	Sub-operations terminated due to Cancel Indication	FE00	(0000,1020) (0000,1021) (0000,1022) (0000,1023)
Warning	Sub-operations Complete - One or more Failures of Warnings	B000	(0000,1020) (0000,1021) (0000,1022) (0000,1023)
Pending	Sub-operations are continuing	FF00	(0000,1020) (0000,1021) (0000,1022) (0000,1023)
Success	Sub-operations Complete - No Failures or Warning	0000	(0000,1020) (0000,1021) (0000,1022) (0000,1023)

Print AE Specification

The print management SCU invokes print management DIMSE services to transfer images from the local AE to the remote SCP AE to print the images with the defined film format and size on a selected network DICOM hardcopy printer. See DICOM part 4 annex H.

Somaris/5 DICOM implementation provides Standard Conformance to the following DICOM V3.0 Basic Grayscale Print Management Meta SOP Class, Basic Color Print Management Meta SOP Class and the optional Print Job SOP Class as an SCU:

Basic Gray Scale Print Management Meta SOP-Classes

SOP Class Name	SOP Class UID	Usage SCU/SCP
Basic Grayscale Print Management Meta SOP Class	1.2.840.10008.5.1.1.9	M/M
– Basic Film Session SOP Class	1.2.840.10008.5.1.1.1	M/M
– Basic Film Box SOP Class	1.2.840.10008.5.1.1.2	M/M
– Basic Grayscale Image Box SOP Class	1.2.840.10008.5.1.1.4	M/M
– Printer SOP Class	1.2.840.10008.5.1.1.16	M/M
– Print Job SOP Class	1.2.840.10008.5.1.1.14	U/U
– Presentation LUT SOP Class	1.2.840.10008.5.1.1.23	U/U



Color Print Management Meta SOP-Classes		
SOP Class Name	SOP Class UID	Usage SCU/SCP
Basic Color Print Management Meta SOP Class	1.2.840.10008.5.1.1.18	M/M
– Basic Film Session SOP Class	1.2.840.10008.5.1.1.1	M/M
– Basic Film Box SOP Class	1.2.840.10008.5.1.1.2	M/M
– Basic Color Image Box SOP Class	1.2.840.10008.5.1.1.4.1	M/M
Printer SOP Class	1.2.840.10008.5.1.1.16	M/M
Print Job SOP Class	1.2.840.10008.5.1.1.14	U/U

Association Establishment Policies

General

The configuration of the Somaris/5 DICOM print management SCU defines the Application Entity Titles, the port numbers and of course the host name and net address.

Number of Associations

The Somaris/5 DICOM application initiates one/several association(s) at a time, one for each transfer request being processed.

Asynchronous Nature

The Somaris/5 DICOM implementation does not support asynchronous communication (multiple outstanding transactions over a single association).

Implementation Identifying Information

The Somaris/5 DICOM implementation provides the Implementation Class UID of

❑ "1.3.12.2.1107.5.1.4"

and an Implementation Version Name of

❑ "SIEMENS_S5VA45C".

Association Initiation Policy

The Print Management SCU and SCP establish an association by using the DICOM association services. During association establishment the Print Management application entities negotiate the supported SOP classes to exchange the capabilities of the SCU and the SCP. If the SCU supports only mandatory SOP classes, the negotiation of optional capabilities is not necessary.

Real-World Activity

Associated Real-World Activity

The associated Real-World activity is to print over a network a set of images on a film sheet with one or more copies. The images are converted to Standard\1-1. If the response from the remote application contains a status other than Success or Warning the association is aborted.

Proposed Presentation Contexts

The Somaris/5 DICOM application will propose Presentation Contexts as shown in the following table:

Presentation Context Table					
Abstract Syntax		Transfer Syntax		Role	Extended Negotiation
Name	UID	Name List	UID List		
Basic Grayscale Print Management Meta SOP class	1.2.840.10008.5.1.1.9	DICOM Implicit VR Little Endian Transfer Syntax	1.2.840.10008.1.2	SCU	None
		DICOM Explicit VR Little Endian Transfer Syntax	1.2.840.10008.1.2.1		
		DICOM Explicit VR Big Endian Transfer Syntax,	1.2.840.10008.1.2.2		
Basic film session SOP class	1.2.840.10008.5.1.1.1	DICOM Implicit VR Little Endian Transfer Syntax	1.2.840.10008.1.2	SCU	None
		DICOM Explicit VR Little Endian Transfer Syntax	1.2.840.10008.1.2.1		
		DICOM Explicit VR Big Endian Transfer Syntax,	1.2.840.10008.1.2.2		
Basic film box SOP class	1.2.840.10008.5.1.1.2	DICOM Implicit VR Little Endian Transfer Syntax	1.2.840.10008.1.2	SCU	None
		DICOM Explicit VR Little Endian Transfer Syntax	1.2.840.10008.1.2.1		
		DICOM Explicit VR Big Endian Transfer Syntax,	1.2.840.10008.1.2.2		

Basic grayscale image box SOP class	1.2.840.10008.5.1.1.4	DICOM Implicit VR Little Endian Transfer Syntax	1.2.840.10008.1.2	SCU	None
		DICOM Explicit VR Little Endian Transfer Syntax	1.2.840.10008.1.2.1		
		DICOM Explicit VR Big Endian Transfer Syntax,	1.2.840.10008.1.2.2		
Printer SOP class	1.2.840.10008.5.1.1.16	DICOM Implicit VR Little Endian Transfer Syntax	1.2.840.10008.1.2	SCU	None
		DICOM Explicit VR Little Endian Transfer Syntax	1.2.840.10008.1.2.1		
		DICOM Explicit VR Big Endian Transfer Syntax,	1.2.840.10008.1.2.2		
Print Job SOP class	1.2.840.10008.5.1.1.14	DICOM Implicit VR Little Endian Transfer Syntax	1.2.840.10008.1.2	SCU	None
		DICOM Explicit VR Little Endian Transfer Syntax	1.2.840.10008.1.2.1		
		DICOM Explicit VR Big Endian Transfer Syntax,	1.2.840.10008.1.2.2		
Presentation LUT SOP class	1.2.840.10008.5.1.1.23	DICOM Implicit VR Little Endian Transfer Syntax	1.2.840.10008.1.2	SCU	None
		DICOM Explicit VR Little Endian Transfer Syntax	1.2.840.10008.1.2.1		
		DICOM Explicit VR Big Endian Transfer Syntax,	1.2.840.10008.1.2.2		



Presentation Context Table

Abstract Syntax		Transfer Syntax		Role	Extended Negotiation
Name	UID	Name List	UID List		
Basic Color Print Management Meta SOP class	1.2.840.10008.5.1.1.18	DICOM Implicit VR Little Endian Transfer Syntax	1.2.840.10008.1.2	SCU	None
		DICOM Explicit VR Little Endian Transfer Syntax	1.2.840.10008.1.2.1		
		DICOM Explicit VR Big Endian Transfer Syntax,	1.2.840.10008.1.2.2		
Basic film session SOP class	1.2.840.10008.5.1.1.1	DICOM Implicit VR Little Endian Transfer Syntax	1.2.840.10008.1.2	SCU	None
		DICOM Explicit VR Little Endian Transfer Syntax	1.2.840.10008.1.2.1		
		DICOM Explicit VR Big Endian Transfer Syntax,	1.2.840.10008.1.2.2		
Basic film box SOP class	1.2.840.10008.5.1.1.2	DICOM Implicit VR Little Endian Transfer Syntax	1.2.840.10008.1.2	SCU	None
		DICOM Explicit VR Little Endian Transfer Syntax	1.2.840.10008.1.2.1		
		DICOM Explicit VR Big Endian Transfer Syntax,	1.2.840.10008.1.2.2		
Basic color image box SOP class	1.2.840.10008.5.1.1.4.1	DICOM Implicit VR Little Endian Transfer Syntax	1.2.840.10008.1.2	SCU	None
		DICOM Explicit VR Little Endian Transfer Syntax	1.2.840.10008.1.2.1		
		DICOM Explicit VR Big Endian Transfer Syntax,	1.2.840.10008.1.2.2		



Printer SOP class	1.2.840.10008.5.1.1.16	DICOM Implicit VR Little Endian Transfer Syntax	1.2.840.10008.1.2	SCU	None
		DICOM Explicit VR Little Endian Transfer Syntax	1.2.840.10008.1.2.1		
		DICOM Explicit VR Big Endian Transfer Syntax,	1.2.840.10008.1.2.2		
Print Job SOP class	1.2.840.10008.5.1.1.14	DICOM Implicit VR Little Endian Transfer Syntax	1.2.840.10008.1.2	SCU	None
		DICOM Explicit VR Little Endian Transfer Syntax	1.2.840.10008.1.2.1		
		DICOM Explicit VR Big Endian Transfer Syntax,	1.2.840.10008.1.2.2		

SOP Specific Conformance Statement

The Somaris/5 DICOM SCU conforms to the DICOM Basic Grayscale Print Management Meta SOP Class and Basic Color Print Management Meta SOP Class.

The application uses a setting platform to define the properties of the connected DICOM SCP, e.g.:

- maximum number of print jobs in the queue
- maximum number of print copies
- supported film sizes of the connected DICOM SCP
- supported film formats of the DICOM SCP
- lookup table definition

The printing is only suspended in the case of a failure return status of the SCP.

SOP Specific Conformance to Basic Film Session SOP Class

The Basic Film Session information object definition describes all the user defined parameter which are common for all the films of a film session. The Basic Film Session refers to one or more Basic Film Boxes and that are printed on one hardcopy printer.

The Somaris/5 DICOM Print application supports the following DIMSE Service Elements for the Basic Film Session SOP class as SCU:

- N-CREATE
- N-DELETE

The Basic Film Session SOP class N_CREATE_RQ (SCU) uses following attributes:

Attribute name	Tag	Usage SCU	Supported Values
Number of Copies	(2000,0010)	U	
Medium Type	(2000,0030)	U	BLUE FILM CLEAR FILM PAPER
Film Destination	(2000,0040)	U	MAGAZINE PROCESSOR

The Affected SOP Instance UID received in N_CREATE_RSP message from SCP will be saved internally and used for later requests like N_DELETE_RQ on the Basic Film Session SOP Class - see table below:

Attribute name	Tag	Source of information
Requested SOP Instance UID	(0008,0018)	Affected SOP Instance UID of N_CREATE_RSP on Basic Film Session

The N_DELETE_RQ on the Basic Film Session SOP Class is used to delete the complete Basic Film Session SOP Instance hierarchy.

The Basic Film Session SOP class interprets following status codes (from N_CREATE_RSP, N_DELETE_RSP messages):

Service Status	Meaning	Protocol Codes
Failure	Film session SOP instances hierarchy does not contain film box SOP instances	C600
	Unable to create print job, print queue is full	C601
	Image size is larger than images box size	C603
Warning	Memory allocation not supported	B600
	Film session printing is not supported	B601
Warning	Film box does not contain image box (empty page)	B602
Success	Film belonging to the film session are accepted for printing	0000

SOP Specific Conformance to Basic Film Box SOP Class

The Basic Film Box information object definition describes all the user defined parameter of one film of the film session. The Basic Film Box information description defines the presentation parameters which are common for all images on a given sheet of film.

The Basic Film Box refers to one or more Image Boxes.

Supported as SCU are:

- N-CREATE
- N-ACTION
- N-DELETE

The Basic Film Box SOP class N_CREATE_RQ message uses following attributes (the used values for each attribute depend how the DICOM Printer is configured within the Siemens product):

Attribute name	Tag	Usage SCU	Supported Values
Image Display Format	(2010,0010)	M	STANDARD\1-1
Referenced Film Session Sequence	(2010,0500)	M	
>Referenced SOP Class UID	(0008,1150)	M	1.2.840.10008.5.1.1.1
>Referenced SOP Instance UID	(0008,1155)	M	
Film Orientation	(2010,0040)	M	PORTRAIT
Film Size ID	(2010,0050)	M	8INX10IN 10INX14IN 11INX14IN 14INX14IN 14INX17IN 24CMX24CM 24CMX30CM

Attribute name	Tag	Usage SCU	Supported Values
Magnification Type	(2010,0060)	M	BILINEAR CUBIC NONE REPLICATE
Max Density	(2010,0130)	U	
Min Density	(2010,0120)	U	
Illumination	(2010,015E)	U	>0 Required if Presentation LUT is present
Reflective Ambient Light	(2010,0160)	U	>0 Required if Presentation LUT is present
Referenced Presentation LUT SOP Class UID	(2050,0500)	U	

The N_CREATE_RSP message from the SCP then contains the References Image Box Sequence with its SOP Class and Instance UIDs which is stored internally and then used for the Basic Image Box SOP Class N-SET RQ messages.

After all parameters for the Image boxes on the film sheet have been set then the Somaris/5 DICOM print application SCU will issue a N_ACTION_RQ message with the SOP Instance UID of the Basic Film Box (returned in N_CREATE_RSP of Basic Film Box SOP class) and the Action Type ID set to 1.



The Affected SOP Instance UID received in N_CREATE_RSP message from SCP will be saved internally and can be used later for N_DELETE_RQ request on the Basic Film Box SOP Class - see table below:

Attribute name	Tag	Source of information
Requested SOP Instance UID	(0008,0018)	Affected SOP Instance UID of N_CREATE_RSP on Basic Film Box

The Basic Film Box SOP class interprets following status codes from the N_CREATE_RSP, N_DELETE_RSP and N_ACTION_RSP messages:

Service Status	Meaning	Protocol Codes
Failure	Unable to create print job; print queue is full	C602
	Image size is larger than image box size	C603
Warning	Film box does not contain image box (empty page)	B603
	Requested MinDensity or MaxDensity outside of printer's operating range	B605
Success	Film accepted for printing	0000

SOP Specific Conformance to Basic Grayscale Image Box SOP Class

The Basic Grayscale Image Box information object definition is the presentation of an image and image related data in the image area of a film. The Basic Image Box information describes the presentation parameters and image pixel data which apply to a single image of a sheet of film.

The Grayscale Image Box SOP class uses only the N_SET_RQ with the following attributes:

Attribute name	Tag	Usage SCU	Supported Values
Image Position	(2020,0010)	M	1
Basic Grayscale Image Sequence	(2020,0110)	M	
>Samples Per Pixel	(0028,0002)	M	1
>Photometric Interpretation	(0028,0004)	M	MONOCHROME2 for Grayscale Images
>Rows	(0028,0010)	M	
>Columns	(0028,0011)	M	
>Pixel Aspect Ratio	(0028,0034)	M	
>Bits Allocated	(0028,0100)	M	8
>Bits Stored	(0028,0101)	M	8
>High Bit	(0028,0102)	M	7
>Pixel Representation	(0028,0103)	M	0
>Pixel Data	(7FE0,0010)	M	

The Grayscale Image Box SOP class interprets following status codes:

Service Status	Meaning	Protocol Codes
Warning	Requested MinDensity or MaxDensity outside of printer's operating range	B605
Failure	Image contains more pixel than printer can print in Image box	C603
	Insufficient memory in printer to store the image	C605
Success		0000

SOP Specific Conformance to Basic Color Image Box SOP Class

The Basic Color Image Box information object definition is the presentation of an image and image related data in the image area of a film. The Basic Image Box information describes the presentation parameters and image pixel data which apply to a single image of a sheet of film.

The Color Image Box SOP class uses only the N_SET_RQ with the following attributes:

Attribute name	Tag	Usage SCU	Supported Values
Image Position	(2020,0010)	M	1
Basic Color Image Sequence	(2020,0111)	M	
>Samples Per Pixel	(0028,0002)	M	3
>Photometric Interpretation	(0028,0004)	M	RGB
>Planar Configuration	(0028,0006)	M	0
>Rows	(0028,0010)	M	
>Columns	(0028,0011)	M	
>Pixel Aspect Ratio	(0028,0034)	M	
>Bits Allocated	(0028,0100)	M	8
>Bits Stored	(0028,0101)	M	8
>High Bit	(0028,0102)	M	7
>Pixel Representation	(0028,0103)	M	0
>Pixel Data	(7FE0,0010)	M	

The Color Image Box SOP class interprets following status codes:

Service Status	Meaning	Protocol Codes
Warning	Image size larger than image box size.	B604
Failure	Image contains more pixel than printer can print in Image box	C603
	Insufficient memory in printer to store the image	C605
Success		0000

SOP Specific Conformance to PresentationLUT SOP Class

The Presentation LUT Information Object is the Presentation LUT. The objective of the Presentation LUT is to realize image hardcopy printing tailored for specific modalities, applications, and user preferences.

The output of the Presentation LUT is Presentation Values (P-Values). P-Values are approximately related to human perceptual response. They are intended to facilitate common input for hardcopy. P-Values are intended to be independent of the specific class or characteristics of the hardcopy device.

Attributes of the N_CREATE_RQ on the Presentation LUT SOP Class

Attribute name	Tag	Usage SCU	Supported Values
Presentation LUT Shape	(2050,0020)	U	IDENTITY

Attributes of the N_CREATE_RSP on the Presentation LUT SOP Class

Attribute of Presentation LUT	Type	Value List	Note
Affected SOP Instance UID	CString	-	After receiving the N_CREATE_RSP, the Affected SOP Instance UID has to be saved and used for later actions (e.g. N_CREATE_RQ ^a , N_DELETE_RQ) on the presentation LUT SOP Class.

a. Note: N_CREATE_RQ on the Basic Film Box requires this UID to be set, if the Presentation LUT SOP Class is to be supported by the SCU.

b. Note: N_CREATE_RQ on the Basic Film Box is required to include the attributes: Illumination, and Reflective Ambient Light, if the Presentation LUT SOP class is to be supported by the SCU.



Attributes of the N_DELETE_RQ on the Presentation LUT SOP Class

Attribute of Presentation LUT	Source of information on this attribute	Type	Value List	Note
Requested SOP Instance UID	Affected SOP Instance UID of N_CREATE_RSP on Presentation LUT	CString	-	-

The N_DELETE_RQ on the Presentation LUT SOP Class is used to delete the complete Presentation LUT SOP Instance hierarchy.

There is no attribute contained in the response message from the SCP which is interesting for the SCU for further use.

The Presentation LUT SOP class interprets the following status codes from the N_CREATE_RSP, N_DELETE_RSP messages:

Service Status	Meaning	Protocol Codes
Warning	Requested Min Density or Max Density outside the HCD's operating range. HCD will use its respective minimum or maximum density value instead.	B605
Success	Presentation LUT successfully created	0000

SOP Specific Conformance to Printer SOP Class

The Printer SOP Class is the possibility to monitor the status of the hardcopy printer in a synchronous and an asynchronous way.

The Somaris/5 DICOM Print application uses the mandatory N-EVENT Report DIMSE service to monitor the changes of the printer status in an asynchronous way.

It can directly ask the Print SCP for its status or can receive Events from the Print SCP asynchronously:

- N_GET as SCU
- N_EVENT_REPORT as SCU

In this case the following information is supported:

Event type name	Event	Attributes	Tag	Usage SCU
Normal	1			
Warning	2	Printer Status Info	(2110,0020)	U
Failure	3	Printer Status Info	(2110,0020)	U

Attribute name	Tag	Usage SCP	supported values
Printer Status	(2110,0010)	M	NORMAL FAILURE WARNING
Printer Status Info	(2110,0020)	M	see → page A.2–83.

For a detailed description of how Somaris/5 reacts to the various messages please refer to → page A.2–83, *Behavior of SCU when receiving information*.

SOP Specific Conformance to Print Job SOP Class

The Print Job SOP Class is the possibility to monitor the execution of the print process.

The Somaris/5 DICOM Print application supports the optional N-EVENT report DIMSE service to receive the changes of the print job status in an asynchronous way.

It can receive events from the Print SCP asynchronously:

- N-EVENT-REPORT

The following information is supported:

Event type name	Event	Attributes	Tag	Usage SCU
Normal	1	Execution Status Info	(2100,0030)	U
		Print Job ID	(2100,0010)	- (Print Queue Management SOP Class not supported)
		Film Session Label	(2000,0050)	U
		Printer Name	(2110,0030)	U



Event type name	Event	Attributes	Tag	Usage SCU
Printing	2	Execution Status Info	(2100,0030)	U
		Print Job ID	(2100,0010)	- (Print Queue Management SOP Class not supported)
		Film Session Label	(2000,0050)	U
		Printer Name	(2110,0030)	U
		Done	3	Execution Status Info
Print Job ID	(2100,0010)	- (Print Queue Management SOP Class not supported)		
Film Session Label	(2000,0050)	U		
Printer Name	(2110,0030)	U		
Failure	4	Execution Status Info		(2100,0030)
		Print Job ID	(2100,0010)	- (Print Queue Management SOP Class not supported)
		Film Session Label	(2000,0050)	U
		Printer Name	(2110,0030)	U

For a detailed description of how Somaris/5 reacts to the various messages please refer to → page A.2–83, *Behavior of SCU when receiving information*.

Behavior of SCU when receiving information

The following tables document the behavior of the Somaris/5 system in response to messages received for the printer SOP class and the print job SOP class.

Printer Status Infos within Printer SOP Class/Execution Status Infos within Print Job SOP Class

Printer Status info/Execution Status info	Description	Message string visible in the Status Bar	Other action for <i>syngal</i> camera symbol
NORMAL	Camera is ready.	Camera is ready.	<None>/idle
BAD RECEIVE MGZ	There is a problem with the film receive magazine. Films from the printer cannot be transported into the magazine.	Problem with receive magazine.	<None>/interact
BAD SUPPLY MGZ	There is a problem with a film supply magazine. Films from this magazine cannot be transported into the printer.	Problem with supply magazine.	<None>/interact
CALIBRATING	Printer is performing self calibration, it is expected to be available for normal operation shortly.	Self calibration. Please wait.	<None>/idle
CALIBRATION ERR	An error in the printer calibration has been detected, quality of processed films may not be optimal.	Problem in calibration. Film quality may not be optimal.	<None>/interact
CHECK CHEMISTRY	A problem with the processor chemicals has been detected, quality of processed films may not be optimal.	Problem with chemistry. Film quality may not be optimal.	<None>/interact
CHECK SORTER	There is an error in the film sorter.	Error in film sorter.	<None>/interact

Printer Status Infos within Printer SOP Class/Execution Status Infos within Print Job SOP Class

Printer Status info/Execution Status info	Description	Message string visible in the Status Bar	Other action for syngo/camera symbol
CHEMICALS EMPTY	There are no processing chemicals in the processor, films will not be printed and processed until the processor is back to normal.	Camera chemistry empty. Please check.	<None>/interact
CHEMICALS LOW	The chemical level in the processor is low, if not corrected, it will probably shut down soon.	Camera chemistry low. Please check.	<None>/interact
COVER OPEN	One or more printer or processor covers, drawers, doors are open.	Camera cover, drawer or door open.	<None>/interact
ELEC CONFIG ERR	Printer configured improperly for this job.	Camera configured improperly for this job. Queue stopped.	Queue for this camera will be STOPPED/ Queue stopped
ELEC DOWN	Printer is not operating due to some unspecified electrical hardware problem.	Camera electrical hardware problem.	<None>/interact
ELEC SW ERROR	Printer not operating for some unspecified software error.	Camera software problem. Queue stopped.	Queue for this camera will be STOPPED/ queue stopped
EMPTY 8x10	The 8x10 inch film supply magazine is empty.	8x10 film supply empty.	<None>/interact
EMPTY 8x10 BLUE	The 8x10 inch blue film supply magazine is empty.	8x10 blue film supply empty.	<None>/interact
EMPTY 8x10 CLR	The 8x10 inch clear film supply magazine is empty.	8x10 clear film supply empty.	<None>/interact
EMPTY 8x10 PAPER	The 8x10 inch paper supply magazine is empty.	8x10 paper supply empty.	<None>/interact



Printer Status Infos within Printer SOP Class/Execution Status Infos within Print Job SOP Class

Printer Status info/Execution Status info	Description	Message string visible in the Status Bar	Other action for <i>syngo</i>/camera symbol
EMPTY 10x12	The 10x12 inch film supply magazine is empty.	10x12 film supply empty.	<None>/interact
EMPTY 10x12 BLUE	The 10x12 inch blue film supply magazine is empty.	10x12 blue film supply empty.	<None>/interact
EMPTY 10x12 CLR	The 10x12 inch clear film supply magazine is empty.	10x12 clear film supply empty.	<None>/interact
EMPTY 10x12 PAPER	The 10x12 inch paper supply magazine is empty.	10x12 paper supply empty.	<None>/interact
EMPTY 10x14	The 10x14 inch film supply magazine is empty.	10x14 film supply empty.	<None>/interact
EMPTY 10x14 BLUE	The 10x14 inch blue film supply magazine is empty.	10x14 blue film supply empty.	<None>/interact
EMPTY 10x14 CLR	The 10x14 inch clear film supply magazine is empty.	10x14 clear film supply empty.	<None>/interact
EMPTY 10x14 PAPER	The 10x14 inch paper supply magazine is empty.	10x14 paper supply empty.	<None>/interact
EMPTY 11x14	The 11x14 inch film supply magazine is empty.	11x14 film supply empty.	<None>/interact
EMPTY 11x14 BLUE	The 11x14 inch blue film supply magazine is empty.	11x14 blue film supply empty.	<None>/interact
EMPTY 11x14 CLR	The 11x14 inch clear film supply magazine is empty.	11x14 clear film supply empty.	<None>/interact
EMPTY 11x14 PAPER	The 11x14 inch paper supply magazine is empty.	11x14 paper supply empty.	<None>/interact

Printer Status Infos within Printer SOP Class/Execution Status Infos within Print Job SOP Class

Printer Status info/Execution Status info	Description	Message string visible in the Status Bar	Other action for <i>syngo</i>/camera symbol
EMPTY 14x14	The 14x14 inch film supply magazine is empty.	14x14 film supply empty.	<None>/interact
EMPTY 14x14 BLUE	The 14x14 inch blue film supply magazine is empty.	14x14 blue film supply empty.	<None>/interact
EMPTY 14x14 CLR	The 14x14 inch clear film supply magazine is empty.	14x14 clear film supply empty.	<None>/interact
EMPTY 14x14 PAPER	The 14x14 inch paper supply magazine is empty.	14x14 paper supply empty.	<None>/interact
EMPTY 14x17	The 14x17 inch film supply magazine is empty.	14x17 film supply empty.	<None>/interact
EMPTY 14x17 BLUE	The 14x17 inch blue film supply magazine is empty.	14x17 blue film supply empty.	<None>/interact
EMPTY 14x17 CLR	The 14x17 inch clear film supply magazine is empty.	14x17 clear film supply empty.	<None>/interact
EMPTY 14x17 PAPER	The 14x17 inch paper supply magazine is empty.	14x17 paper supply empty.	<None>/interact
EMPTY 24x24	The 24x24 inch film supply magazine is empty.	24x24 film supply empty.	<None>/interact
EMPTY 24x24 BLUE	The 24x24 inch blue film supply magazine is empty.	24x24 blue film supply empty.	<None>/interact
EMPTY 24x24 CLR	The 24x24 inch clear film supply magazine is empty.	24x24 clear film supply empty.	<None>/interact
EMPTY 24x24 PAPER	The 24x24 inch paper supply magazine is empty.	24x24 paper supply empty.	<None>/interact



Printer Status Infos within Printer SOP Class/Execution Status Infos within Print Job SOP Class

Printer Status info/Execution Status info	Description	Message string visible in the Status Bar	Other action for <i>syngol</i> camera symbol
EMPTY 24x30	The 24x30 inch film supply magazine is empty.	24x30 film supply empty.	<None>/interact
EMPTY 24x30 BLUE	The 24x30 inch blue film supply magazine is empty.	24x30 blue film supply empty.	<None>/interact
EMPTY 24x30 CLR	The 24x30 inch clear film supply magazine is empty.	24x30 clear film supply empty.	<None>/interact
EMPTY 24x30 PAPER	The 24x30 inch paper supply magazine is empty.	24x30 paper supply empty.	<None>/interact
EMPTY A4 PAPER	The A4 paper supply magazine is empty.	A4 paper supply empty.	<None>/interact
EMPTY A4 TRANS	The A4 transparency supply magazine is empty.	A4 transparency supply empty.	<None>/interact
EXPOSURE FAILURE	The exposure device has failed due to some unspecified reason.	Exposure device has failed.	<None>/interact
FILM JAM	A film transport error has occurred and a film is jammed in the printer or processor.	Film jam.	<None>/interact
FILM TRANSP ERR	There is a malfunction with the film transport, there may or may not be a film jam.	Film transport problem.	<None>/interact
FINISHER EMPTY	The finisher is empty.	Finisher is empty.	<None>/interact
FINISHER ERROR	The finisher is not operating due to some unspecified reason.	Finisher problem.	<None>/interact
FINISHER LOW	The finisher is low on supplies.	Finisher low.	<None>/interact

Printer Status Infos within Printer SOP Class/Execution Status Infos within Print Job SOP Class

Printer Status info/Execution Status info	Description	Message string visible in the Status Bar	Other action for <i>syngo</i>/camera symbol
LOW 8x10	The 8x10 inch film supply magazine is low.	8x10 film supply low.	<None>/interact
LOW 8x10 BLUE	The 8x10 inch blue film supply magazine is low.	8x10 blue film supply low.	<None>/interact
LOW 8x10 CLR	The 8x10 inch clear film supply magazine is low.	8x10 clear film supply low.	<None>/interact
LOW 8x10 PAPR	The 8x10 inch paper supply magazine is low.	8x10 paper supply low.	<None>/interact
LOW 10x12	The 10x12 inch film supply magazine is low.	10x12 film supply low.	<None>/interact
LOW 10x12 BLUE	The 10x12 inch blue film supply magazine is low.	10x12 blue film supply low.	<None>/interact
LOW 10x12 CLR	The 10x12 inch clear film supply magazine is low.	10x12 clear film supply low.	<None>/interact
LOW 10x12 PAPR	The 10x12 inch paper supply magazine is low.	10x12 paper supply low.	<None>/interact
LOW 10x14	The 10x14 inch film supply magazine is low.	10x14 film supply low.	<None>/interact
LOW 10x14 BLUE	The 10x14 inch blue film supply magazine is low.	10x14 blue film supply low.	<None>/interact
LOW 10x14 CLR	The 10x14 inch clear film supply magazine is low.	10x14 clear film supply low.	<None>/interact
LOW 10x14 PAPR	The 10x14 inch paper supply magazine is low.	10x14 paper supply low.	<None>/interact



Printer Status Infos within Printer SOP Class/Execution Status Infos within Print Job SOP Class

Printer Status info/Execution Status info	Description	Message string visible in the Status Bar	Other action for <i>syngol</i> camera symbol
LOW 11x14	The 11x14 inch film supply magazine is low.	11x14 film supply low.	<None>/interact
LOW 11x14 BLUE	The 11x14 inch blue film supply magazine is low.	11x14 blue film supply low.	<None>/interact
LOW 11x14 CLR	The 11x14 inch clear film supply magazine is low.	11x14 clear film supply low.	<None>/interact
LOW 11x14 PAPR	The 11x14 inch paper supply magazine is low.	11x14 paper supply low.	<None>/interact
LOW 14x14	The 14x14 inch film supply magazine is low.	14x14 film supply low.	<None>/interact
LOW 14x14 BLUE	The 14x14 inch blue film supply magazine is low.	14x14 blue film supply low.	<None>/interact
LOW 14x14 CLR	The 14x14 inch clear film supply magazine is low.	14x14 clear film supply low.	<None>/interact
LOW 14x14 PAPR	The 14x14 inch paper supply magazine is low.	14x14 paper supply low.	<None>/interact
LOW 14x17	The 14x17 inch film supply magazine is low.	14x17 film supply low.	<None>/interact
LOW 14x17 BLUE	The 14x17 inch blue film supply magazine is low.	14x17 blue film supply low.	<None>/interact
LOW 14x17 CLR	The 14x17 inch clear film supply magazine is low.	14x17 clear film supply low.	<None>/interact
LOW 14x17 PAPR	The 14x17 inch paper supply magazine is low.	14x17 paper supply low.	<None>/interact

Printer Status Infos within Printer SOP Class/Execution Status Infos within Print Job SOP Class

Printer Status info/Execution Status info	Description	Message string visible in the Status Bar	Other action for syngo/camera symbol
LOW 24x24	The 24x24 inch film supply magazine is low.	24x24 film supply low.	<None>/interact
LOW 24x24 BLUE	The 24x24 inch blue film supply magazine is low.	24x24 blue film supply low.	<None>/interact
LOW 24x24 CLR	The 24x24 inch clear film supply magazine is low.	24x24 clear film supply low.	<None>/interact
LOW 24x24 PAPER	The 24x24 inch paper supply magazine is low.	24x24 paper supply low.	<None>/interact
LOW 24x30	The 24x30 inch film supply magazine is low.	24x30 film supply low.	<None>/interact
LOW 24x30 BLUE	The 24x30 inch blue film supply magazine is low.	24x30 blue film supply low.	<None>/interact
LOW 24x30 CLR	The 24x30 inch clear film supply magazine is low.	24x30 clear film supply low.	<None>/interact
LOW 24x30 PAPER	The 24x30 inch paper supply magazine is low.	24x30 paper supply low.	<None>/interact
LOW A4 PAPER	The A4 paper supply magazine is low.	A4 paper supply low.	<None>/interact
LOW A4 TRANS	The A4 transparency supply magazine is low.	A4 transparency supply low.	<None>/interact
NO RECEIVE MGZ	The film receive magazine no available.	Film receiver not available.	<None>/interact
NO RIBBON	The ribbon cartridge needs to be replaced.	Replace ribbon cartridge.	<None>/interact



Printer Status Infos within Printer SOP Class/Execution Status Infos within Print Job SOP Class

Printer Status info/Execution Status info	Description	Message string visible in the Status Bar	Other action for <i>syngol</i> /camera symbol
NO SUPPLY MGZ	The film supply magazine specified for this job is not available.	Film supply not available.	<None>/interact
CHECK PRINTER	The printer is not ready at this time, operator intervention is required to make the printer available.	Check camera.	<None>/interact
CHECK PROC	The processor is not ready at this time, operator intervention is required to make the printer available.	Check processor.	<None>/interact
PRINTER DOWN	The printer is not operating due to some unspecified reason.	Camera down.	<None>/interact
PRINTER INIT	The printer is not ready at this time, it is expected to become available without intervention, For example, it may be in a normal warm-up state.	Camera initializing.	<None>/idle
PRINTER OFFLINE	The printer has been disabled by an operator or service person.	Camera off-line.	<None>/interact
PROC DOWN	The processor is not operating due to some unspecified reason.	Processor down.	<None>/interact
PROC INIT	The processor is not ready at this time, it is expected to become available without intervention. For example, it may be in a normal warm-up state.	Processor initializing.	<None>/idle

Printer Status Infos within Printer SOP Class/Execution Status Infos within Print Job SOP Class

Printer Status info/Execution Status info	Description	Message string visible in the Status Bar	Other action for syngo/camera symbol
PROC OVERFLOW FL	Processor chemicals are approaching the overflow full mark.	Processor chemicals overflow.	<None>/interact
PROC OVERFLOW HI	Processor chemicals have reached the overflow full mark.	Processor chemicals near overflow.	<None>/interact
QUEUED	Print job in Queue	-	<None>/idle
RECEIVER FULL	The Film receive magazine is full.	Receiver full.	<None>/interact
REQ MED NOT INST	The requested film, paper, or other media supply magazine is installed in the printer, but may be available with operator intervention.	Install media supply.	<None>/interact
REQ MED NOT AVAI	The requested film, paper, or other media requested is not available on this printer.	Media supply not available on this camera. Queue stopped. Change camera.	Queue for this camera will be STOPPED/queue stopped
RIBBON ERROR	There is an unspecified problem with the print ribbon.	Error with print ribbon.	<None>/interact
SUPPLY EMPTY	The printer is out of film.	Camera out of film.	<None>/interact
SUPPLY LOW	The film supply is low.	Film supply low.	<None>/interact
UNKNOWN	There is an unspecified problem.	Unspecified problem with camera.	<None>/interact



Printer Status Infos: Additional Agfa printer status infos

PrinterStatusinfo	Description	Message string visible in the Status Bar	Other action for <i>syngo</i> / camera symbol
WARMING UP	Printer is in the warm-up stage. Spooling of print jobs to disk is still possible.	Camera is warming up.	<None>idle
OFFLINE	Printer is switched off-line. Spooling of print jobs to disk is still possible.	Camera is switched off-line.	<None>/interact
NONE	General printer warning, no specific information is available. Spooling of print jobs to disk is still possible.	-	<None>/idle

Printer Status Infos: Additional Kodak infos for Pacs Link (formerly Imation cameras)

PrinterStatusinfo	Description	Message string visible in the Status Bar	Other action for <i>syngo</i> / camera symbol
SUPPLY MGZ ERR	The supply magazine has an error.	Film supply has an error.	<None>/interact

Printer Status Infos: Additional Kodak infos for Kodak 190

PrinterStatusinfo	Description	Message string visible in the Status Bar	Other action for <i>syngo</i> / camera symbol
PRINTER STOPPED	The printer has stopped	Camera has stopped.	<None>/interact
FATAL ERROR	Fatal error.	Fatal error. Queue stopped.	Queue for this camera will be STOPPED/ queue stopped

Printer Status Infos: Additional Kodak infos for 2180/1120

PrinterStatusinfo	Description	Message string visible in the Status Bar	Other action for <i>syngo</i>/ camera symbol
PRINTER NOT RDY	Printer not ready.	Camera not ready.	<None>/interact
CHECK PROCESSOR	Check processor.	Check processor.	<None>/interact
NO TONER	No toner.	No toner.	<None>/interact
FATAL	Fatal error.	Fatal error. Queue stopped.	Queue for this camera will be STOPPED/ queue stopped

Printer Status Infos: Additional Codonics infos

PrinterStatusinfo	Description	Message string visible in the Status Bar	Other action for <i>syngo</i>/ camera symbol
STANDARD	Printer is ready.	Camera is ready.	<None>/Normal
LOAD A-SIZE	Load A-size media.	Load A-size media.	<None>/interact
LOAD A-DVPAPER	Load A-size black and white paper.	Load A-size black and white paper.	<None>/interact
LOAD A-CVPAPER	Load A-size color paper.	Load A-size color paper.	<None>/interact
LOAD A-CVTRANS	Load A-size transparencies.	Load A-size transparencies.	<None>/interact
LOAD A4-SIZE	Load A4-size media.	Load A4-size media.	<None>/interact
LOAD A4-DVPAPER	Load A4-size black and white paper.	Load A4-size black and white paper.	<None>/interact
LOAD A4-CVPAPER	Load A4-size color paper.	Load A4-size color paper.	<None>/interact



Printer Status Infos: Additional Codonics infos

PrinterStatusinfo	Description	Message string visible in the Status Bar	Other action for <i>syngo</i>/ camera symbol
LOAD A4-CVTRANS	Load A4-size transparencies.	Load A4-size transparencies.	<None>/interact
LOAD LA-SIZE	Load LA-size media.	Load LA-size media.	<None>/interact
LOAD LA-DVPAPER	Load LA-size black and white paper.	Load LA-size black and white paper.	<None>/interact
LOAD LA-CVPAPER	Load LA-size color paper.	Load LA-size color paper.	<None>/interact
LOAD LA-CVTRANS	Load LA-size transparencies.	Load LA-size transparencies.	<None>/interact
LOAD LA4-SIZE	Load LA4-size media.	Load LA4-size media.	<None>/interact
LOAD LA4-DVPAPER	Load LA4-size black and white paper.	Load LA4-size black and white paper.	<None>/interact
LOAD LA4-CVPAPER	Load LA4-size color paper.	Load LA4-size color paper.	<None>/interact
LOAD LA4-CVTRANS	Load LA4-size transparencies.	Load LA4-size transparencies.	<None>/interact
LOAD XLA-SIZE	Load XLA-size media.	Load XLA-size media.	<None>/interact
LOAD XLA-DVPAPER	Load XLA-size black and white paper.	Load XLA-size black and white paper.	<None>/interact
LOAD XLA-CVPAPER	Load XLA-size color paper.	Load XLA-size color paper.	<None>/interact
LOAD XLA-CVTRANS	Load XLA-size transparencies.	Load XLA-size transparencies.	<None>/interact
LOAD XLA4-SIZE	Load XLA4-size media.	Load XLA4-size media.	<None>/interact



Printer Status Infos: Additional Codonics infos			
PrinterStatusinfo	Description	Message string visible in the Status Bar	Other action for <i>syngo</i> camera symbol
LOAD XLA4-DVPAPE	Load XLA4-size black and white paper.	Load XLA4-size black and white paper.	<None>/interact
LOAD XLA4-CVPAPE	Load XLA4-size color paper.	Load XLA4-size color paper.	<None>/interact
LOAD XLA4-CVTRAN	Load XLA4-size transparencies.	Load XLA4-size transparencies.	<None>/interact
LOAD XLW-SIZE	Load XLW-size media.	Load XLW-size media.	<None>/interact
LOAD XLW-DVPAPER	Load XLW-size black and white paper.	Load XLW-size black and white paper.	<None>/interact
LOAD XLW-CVPAPER	Load XLW-size color paper.	Load XLW-size color paper.	<None>/interact
LOAD 8X10-SIZE	Load 8x10 media.	Load 8x10 media.	<None>/interact
LOAD 8X10-DVFILM	Load 8x10 black and white film.	Load 8x10 black and white film.	<None>/interact
SUPPLY MISSING	The film supply magazine specified for this job is not available.	Film supply not available.	<None>/interact
RIBBON MISSING	Ribbon is missing.	Ribbon is missing.	<None>/interact
RIBBON EMPTY	Ribbon is empty.	Ribbon is empty.	<None>/interact
TOP COVER OPEN	Top cover of printer is open.	Top cover of camera is open.	<None>/interact



Additional DICOM Execution Status Infos

Execution Status info	Description	Message string visible in the Status Bar	Other action for <i>syngo</i>/ camera symbol
INVALID PAGE DES	The specified page layout cannot be printed or other page description errors have been detected.	Film Job cannot be printed on this camera. Queue stopped. Please redirect film job.	Queue for this camera will be STOPPED/ queue stopped
INSUFFIC MEMORY	There is not enough memory available to complete this job.	Not enough memory available in camera. Queue stopped. Please continue queue or change camera.	Queue for this camera will be STOPPED/ queue stopped
NONE	General printer warning, no specific information is available. Spooling of print jobs to disk is still possible.	-	<None>/idle

Modality Worklist AE Specification

The basic worklist SCU requests that the remote SCP performs a match of all keys specified in the query against the information in its worklist database.

SIEMENS Somaris/5 DICOM implementation provides Standard Conformance to the following DICOM V3.0 SOP Class as an SCU:

SOP Class Name	SOP Class UID
Modality Worklist Information Model - FIND	1.2.840.10008.5.1.4.31

Association Establishment Policies

General

The configuration of the Somaris/5 DICOM Basic Worklist SCU application defines the Application Entity Titles, the port numbers and of course the host name and net address.

Number of Associations

The Somaris/5 DICOM application initiates one/several association(s) at a time, one for each transfer request being processed.

Asynchronous Nature

The Somaris/5 DICOM implementation does not support asynchronous communication (multiple outstanding transactions over a single association).

Implementation Identifying Information

The Somaris/5 DICOM implementation provides the Implementation Class UID of

❑ "1.3.12.2.1107.5.1.4"

and an Implementation Version Name of

❑ "SIEMENS_S5VA45C".

Association Initiation Policy

The modality worklist SCU establish an association by using the DICOM association services.

The following DIMSE-C operation is supported as SCU:

- C-FIND

Real-World Activity

Associated Real-World Activity

The associated Real-World activity is to initiate query requests to an SCP by using the DICOM Worklist Information Model.

Proposed Presentation Contexts

The Somaris/5 DICOM application will propose Presentation Contexts as shown in the following table:

Presentation Context Table						
Abstract Syntax		Transfer Syntax		Role	Extended	
Name	UID	Name List	UID List		Negotiation	
Modality Worklist Information Model - FIND	1.2.840.10008.5.1.4.31	DICOM Implicit VR Little Endian Transfer Syntax	1.2.840.10008.1.2	SCU	None	
		DICOM Explicit VR Little Endian Transfer Syntax	1.2.840.10008.1.2.1			
		DICOM Explicit VR Big Endian Transfer Syntax	1.2.840.10008.1.2.2			

SOP Specific Conformance Statement

Search Key Attributes of the Worklist C-FIND

The Somaris/5 DICOM worklist SCU supports worklist queries with all required search keys and several optional search keys.

The following tables describe the search keys that the SCU supports for a broad worklist query, which is a query for all tasks scheduled for the own modality or own modality application entity defined with the following search keys:

Search Key Attributes in a broad worklist query

Attribute name	Tag	Matching Key Type	query value
Scheduled Procedure Step Sequence	(0040,0100)	R	
>Scheduled Station AE Title	(0040,0001)	R	Configurable ^a : own AET or ""
>Scheduled Procedure Step Start Date	(0040,0002)	R	Configurable: inserted in UI ^b or today
>Scheduled Procedure Step Start Time	(0040,0003)	R	Configurable: inserted in UI ^c or zero length
>Modality	(0008,0060)	R	Configurable ^a : own modality or ""

a. One and only one of the attributes "Modality" and "AE Title" is set to "". There is a configuration parameter telling which of them. The other one is always set to the "own" value (i.e. own modality respectively own AE Title).

b. <startDate>-<endDate>

c. <startTime>-<endTime>

The following table describes the search keys that the SCU supports for a patient based worklist query, which is defined by the following search keys:

Search Key Attributes in a patient based worklist query			
Attribute name	Tag	Matching Key Type	query value
Scheduled Procedure Step			
Scheduled Procedure Step Sequence	(0040,0100)	R	
>Scheduled Performing Physician's Name	(0040,0006)	R	inserted in UI or zero length
Requested Procedure			
Requested Procedure ID	(0040,1001)	O	inserted in UI or zero length
Imaging Service Request			
Accession Number	(0008,0050)	O	inserted in UI or zero length
Referring Physician's Name	(0008,0090)	O	inserted in UI or zero length
Visit Status			
Current Patient Location	(0038,0300)	O	inserted in UI or zero length
Patient Identification			
Patient's Name	(0010,0010)	R	inserted in UI or zero length
Patient ID	(0010,0020)	R	inserted in UI or zero length

Return Key Attributes used from the Worklist C_FIND_RSP

The Somaris/5 DICOM worklist SCU supports worklist queries with return key attributes of all types. The following tables describe the return keys that the SCU supports. Most attributes can be shown in the User Interface (PatientRegistration or PatientBrowser), but in PatientBrowser it is configurable which of them are shown really.

Attribute name	Tag	Return Key Type	displayed in User Interface
SOP Common			
Specific Character Set ^a	(0008,0005)	1C	
Scheduled Procedure Step			
Scheduled Procedure Step Sequence	(0040,0100)	1	-
>Scheduled Station AE Title	(0040,0001)	1	yes
>Scheduled Procedure Step Start Date	(0040,0002)	1	yes
>Scheduled Procedure Step Start Time	(0040,0003)	1	yes
>Scheduled Procedure Step End Date	(0040,0004)	3	-
>Scheduled Procedure Step End Time	(0040,0005)	3	-
>Modality	(0008,0060)	1	yes
>Scheduled Performing Physician's Name	(0040,0006)	1	-
>Scheduled Procedure Step Description	(0040,0007)	1C	yes
>Scheduled Station Name	(0040,0010)	2	-

Attribute name	Tag	Return Key Type	displayed in User Interface
>Scheduled Procedure Step Location	(0040,0011)	2	-
>Scheduled Action Item Code Sequence	(0040,0008)	1C	-
>>Code Value	(0008,0100)	1C	yes
>>Coding Scheme Designator	(0008,0102)	1C	yes
>>Coding Scheme Version	(0008,0102)	3	yes
>>Code Meaning	(0008,0104)	3	yes
>Pre-Medication	(0040,0012)	2C	yes
>Scheduled Procedure Step ID	(0040,0009)	1	yes
>Requested Contrast Agent	(0032,1070)	2C	yes
>Scheduled Procedure Step Status	(0040,0020)	3	yes
>Comments on the Scheduled Procedure Step	(0040,0400)	3	ye
Requested Procedure			
Requested Procedure ID	(0040,1001)	1	yes
Requested Procedure Description	(0032,1060)	1C	yes
Requested Procedure Code Sequence	(0032,1064)	1C	-
>Code Value	(0008,0100)	1C	yes
>Code Scheme Designator	(0008,0102)	1C	yes
>Code Scheme Version	(0008,0103)	3	yes
>Code Meaning	(0008,0104)	3	yes
Study Instance UID	(0020,000D)	1	-
Referenced Study Sequence	(0008,1110)	2	-
>Referenced SOP Class UID	(0008,1150)	1C	-

Attribute name	Tag	Return Key Type	displayed in User Interface
>Referenced SOP Instance UID	(0008,1155)	1C	-
Requested Procedure Priority	(0040,1003)	2	yes
Patient Transport Arrangements	(0040,1004)	2	-
Reason for the Requested Procedure	(0040,1002)	3	-
Confidentiality Code	(0040,1008)	3	-
Reporting Priority	(0040,1009)	3	-
Names of Intended Recipients of results	(0040,1010)	3	-
Requested Procedure Comments	(0040,1400)	3	yes
Requested Procedure Location	(0040,1005)	3	-
Imaging Service Request			
Accession Number	(0008,0050)	2	yes
Requesting Physician	(0032,1032)	2	yes
Referring Physician's Name	(0008,0090)	2	yes
Reason for the Imaging Service Request	(0040,2001)	3	-
Imaging Service Request Comments	(0040,2400)	3	yes
Requesting Service	(0032,1033)	3	yes
Issuing Date of Imaging Service Request	(0040,2004)	3	-
Issuing Time of Imaging Service Request	(0040,2005)	3	-
Placer Order Number / Imaging Service Request	(0040,2006)	3	-
Filler Order Number / Imaging Service Request	(0040,2007)	3	-

Attribute name	Tag	Return Key Type	displayed in User Interface
Order entered by..	(0040,2008)	3	-
Order Enterer's Location	(0040,2009)	3	-
Order Callback Phone Number	(0040,2010)	3	-
Visit Identification			
Admission ID	(0038,0010)	2	yes
Issuer of Admission ID	(0038,0011)	3	-
Visit Status			
Current Patient Location	(0038,0300)	2	yes
Visit Relationship			
Referenced Patient Sequence	(0008,1120)	2	-
>Referenced SOP Class UID	(0008,1150)	2	-
>Referenced SOP Instance UID	(0008,1155)	2	-
Visit Admission			
Institution Name	(0008,0000)	3	yes
Admitting Diagnoses Description	(0008,1080)	3	yes
Patient Identification			
Patient's Name	(0010,0010)	1	yes
Patient ID	(0010,0020)	1	yes
Patient Demographic			
Patients Birth Date	(0010,0030)	2	yes
Patient's Sex	(0010,0040)	2	yes
Patient's Weight	(0010,1030)	2	yes
Confidential constraint on patient data	(0040,3001)	2	yes

Attribute name	Tag	Return Key Type	displayed in User Interface
Patient's Address	(0010,1040)	3	yes
Military Rank	(0010,1080)	3	yes
Ethnic Group	(0010,2160)	3	yes
Patient Comments	(0010,4000)	3	yes
Patient Medical			
Patient State	(0038,0500)	2	yes
Pregnancy Status	(0010,21C0)	2	yes
Medical Alerts	(0010,2000)	2	yes
Contrast Allergies	(0010,2110)	2	yes
Special Needs	(0038,0050)	2	yes
Smoking Status	(0010,21A0)	3	yes
Last Menstrual Date	(0010,21D0)	3	yes
Additional Patient History	(0010,21B0)	3	yes

a. The Specific Character Set distributed via Modality Worklist by the hospital network shall reflect the global hospital context, e.g. a hospital with german context shall not restrict the worklist entries to ISO_IR 6 but supply a character set adequate to hold all german language text input.

Status Codes of the Worklist C-FIND

The worklist SCU interprets following status codes:

Service Status	Meaning	Status Codes (0000,0900)
Refused	Out of Resources	A700
Failed	Identifier does not match SOP Class	A900
	Unable to process	Cxxx
Cancel	Matching terminated due to Cancel request	FE00
Success	Matching is complete - No final Identifier is supplied	0000
Pending	Matches are continuing - Current Match is supplied and any Optional Keys were supported in the same manner as Required Keys	FF00
	Matches are continuing - Warning that one or more Optional Keys were not supported for existence and/or matching for this identifier	FF01

Modality Performed Procedure Step AE Specification

The Modality Performed Procedure Step SCU informs the remote SCP about the performed examinations at the modality.

SIEMENS Somaris/5 DICOM implementation provides Standard Conformance to the following DICOM V3.0 SOP Class as an SCU:

SOP Class Name	SOP Class UID
Modality Performed Procedure Step	1.2.840.10008.3.1.2.3.3

Association Establishment Policies

General

The configuration of the Siemens DICOM Performed Procedure Step application defines the Application Entity Titles, the port numbers and of course the host name and net address.

Number of Associations

The Siemens DICOM application initiates one association(s) at a time, one for each transfer request being processed.

Asynchronous Nature

The Siemens DICOM software does not support asynchronous communication (multiple outstanding transactions over a single association).

Implementation Identifying Information

The Siemens DICOM software provides the Implementation Class UID of

❑ "1.3.12.2.1107.5.1.4"

and an Implementation Version Name of

❑ "SIEMENS_S5VA45C".

Association Initiation Policy

The Modality Performed Procedure Step SCU establishes an association by using the DICOM association services.

The following DIMSE-N operations are supported as SCU:

- N-CREATE
- N-SET

Real World Activity

Associated Real-World Activity

The associated Real-World activity is to send examination information to an SCP by using the DICOM Modality Performed Procedure Step Service.

Proposed Presentation Contexts

The Siemens DICOM application will propose Presentation Contexts as shown in the following table:

Presentation Context Table

Name	Abstract Syntax		Transfer Syntax		Role	Extended Negotiation
	UID		Name List	UID List		
Modality Performed Procedure Step	1.2.840.10008.3.1.2.3.3		DICOM Implicit VR Little Endian Transfer Syntax	1.2.840.10008.1.2	SCU	None
			DICOM Explicit VR Little Endian Transfer Syntax	1.2.840.10008.1.2.1		
			DICOM Explicit VR Big Endian Transfer Syntax	1.2.840.10008.1.2.2		

**SOP Specific
Conformance Statement***Attributes used for the Performed Procedure Step N-CREATE*

The Siemens DICOM performed procedure step SCU informs the remote SCP when the examination of a scheduled procedure step will be performed. The N-CREATE message is sent when the examination is started. The following table describes the supported attributes for a N-CREATE message.

Performed Procedure Step N-CREATE Attributes			
Attribute name	Tag	Required Type	Value
SOP Common			
Specific Character Set	(0008,0005)	1C	from MWL or created
Performed Procedure Step Relationship			
Scheduled Step Attribute Sequence	(0040,0270)	1	
>Study Instance UID	(0020,000D)	1	from MWL or created
>Referenced Study Sequence	(0008,1110)	2	from MWL or zero length
>>Referenced SOP Class UID	(0008,1150)	1C	
>>Referenced SOP Instance UID	(0008,1155)	1C	
>Accession Number	(0008,0050)	2	from MWL or user input
>Placer Order Number / Imaging Service Request	(0040,2016)	3	from MWL or zero length
>Filler Order Number / Imaging Service Request	(0040,2017)	3	from MWL or zero length
>Requested Procedure ID	(0040,1001)	2	from MWL or user input
>Requested Procedure Description	(0032,1060)	2	from MWL or zero length
>Scheduled Procedure Step ID	(0040,0009)	2	from MWL or zero length
>Scheduled Procedure Step Description	(0040,0007)	2	from MWL or zero length
>Scheduled Action Item Code Sequence	(0040,0008)	2	from MWL or zero length
>>Code Value	(0008,0100)	1C	



Performed Procedure Step N-CREATE Attributes

Attribute name	Tag	Required Type	Value
>>Coding Scheme Designator	(0008,0102)	1C	
>>Code Scheme Version	(0008,0103)	3	
>>Code Meaning	(0008,0104)	3	
Patient's Name	(0010,0010)	2	from MWL or user input
Patient ID	(0010,0020)	2	from MWL or user input or created
Patients Birth Date	(0010,0030)	2	from MWL or user input
Patient's Sex	(0010,0040)	2	from MWL or user input
Referenced Patient Sequence	(0008,1120)	2	from MWL or zero length
>Referenced SOP Class UID	(0008,1150)	1C	
>Referenced SOP Instance UID	(0008,1155)	1C	
Performed Procedure Step Information			
Performed Procedure Step ID	(0040,0253)	1	from SPS ID or created
Performed Station AE Title	(0040,0241)	1	own AE Title
Performed Station Name	(0040,0242)	2	own hostname
Performed Location	(0040,0243)	2	from SPS Location or zero length
Performed Procedure Step Start Date	(0040,0244)	1	created
Performed Procedure Step Start Time	(0040,0245)	1	created
Performed Procedure Step Status	(0040,0252)	1	IN PROGRESS
Performed Procedure Step Description	(0040,0254)	2	from SPS Description or zero length

Performed Procedure Step N-CREATE Attributes

Attribute name	Tag	Required Type	Value
Performed Procedure Type Description	(0040,0255)	2	zero length
Procedure Code Sequence	(0008,1032)	2	from Requested Procedure Code or zero length
>Code Value	(0008,0100)	1C	
>Code Scheme Designator	(0008,0102)	1C	
>Code Scheme Version	(0008,0103)	3	
>Code Meaning	(0008,0104)	3	
Performed Procedure Step End Date	(0040,0250)	2	zero length
Performed Procedure Step End Time	(0040,0251)	2	zero length
Image Acquisition Results			
Modality	(0008,0060)	1	CT
Study ID	(0020,0010)	2	from Requested Procedure ID or created
Performed Action Item Code Sequence	(0040,0260)	2	from Scheduled Action Item Code SQ or zero length
>Code Value	(0008,0100)	1C	
>Code Scheme Designator	(0008,0102)	1C	
>Code Scheme Version	(0008,0103)	3	
>Code Meaning	(0008,0104)	3	
Performed Series Sequence	(0040,0340)	2	
>Performing Physicians's Name	(0008,1050)	2C	from MWL or user input
>Protocol Name	(0008,1030)	1C	default value



Performed Procedure Step N-CREATE Attributes

Attribute name	Tag	Required Type	Value
>Operator's Name	(0008,1070)	2C	user input
>Series Instance UID	(0020,000E)	1C	created
>Series Description	(0008,103E)	2C	zero length
>Retrieve AE Title	(0008,0054)	2C	zero length
>Referenced Image Sequence	(0008,1140)	2C	zero length
>Referenced Standalone SOP Instance Sequence	(0040,0220)	2C	zero length

Status Codes of the Performed Procedure Step N-CREATE

The Performed Procedure Step SCU interprets the following status values:

N-SET Response Status		
Service Status	Meaning	Status Codes (0000,0900)
Failure	Processing Failure	0110
	No such attribute	0105
	Invalid attribute value	0106
	Duplicate SOP Instance	0111
	No such SOP Instance	0112
	No such SOP class	0118
	Class instance conflict	0119
	Missing attribute	0120
	Missing attribute value	0121
	Resource limitation	0213
Success	Successful Operation	0000

Attributes used for the Performed Procedure Step N-SET

The Somaris/5 DICOM performed procedure step SCU informs the remote SCP about the performed examination and its status. The N-Set message is sent once for each reconstruction of acquisition data with status "IN_PROGRESS". The N-SET message is sent on user input with status "COMPLETED" or "DISCONTINUED", respectively. This is intended to be used when the examination is finished with status "COMPLETED" or when the examination could not be completed with status "DISCONTINUED" (already sent automatically when examination is ended via End Exam and no acquisition was done). The following table describes the supported attributes for a N-SET message.

Performed Procedure Step N-SET Attributes

Attribute name	Tag	Required Type	Value
Performed Procedure Step Information			
Performed Procedure Step Status	(0040,0252)	3	IN_PROGRESS or COMPLETED or DISCONTINUED (see above)
Performed Procedure Step Description	(0040,0254)	3	from SPS Description or user input
Performed Procedure Type Description	(0040,0255)	3	zero length
Procedure Code Sequence	(0008,1032)	3	from Requested Procedure Code or empty on user change (see IHE Technical Framework Y3, App. C Note 6)
>Code Value	(0008,0100)	1C	
>Code Scheme Designator	(0008,0102)	1C	



Performed Procedure Step N-SET Attributes			
Attribute name	Tag	Required Type	Value
>Code Scheme Version	(0008,0103)	1C	
>Code Meaning	(0008,0104)	1C	
Performed Procedure Step End Date	(0040,0250)	3	created or zero length
Performed Procedure Step End Time	(0040,0251)	3	created or zero length
Image Acquisition Results			
Performed Action Item Code Sequence	(0040,0260)	3	from Scheduled Action Item Code SQ or user input
>Code Value	(0008,0100)	1C	
>Code Scheme Designator	(0008,0102)	1C	
>Code Scheme Version	(0008,0103)	1C	
>Code Meaning	(0008,0104)	1C	
Performed Series Sequence	(0040,0340)	3	
>Performing Physicians's Name	(0008,1050)	2C	from MWL or user input
>Protocol Name	(0018,1030)	1C	name of Scan Protocol
>Operator's Name	(0008,1070)	2C	user input
>Series Instance UID	(0020,000E)	1C	created
>Series Description	(0008,103E)	2C	range name with generated reconstruction information or user input



Performed Procedure Step N-SET Attributes

Attribute name	Tag	Required Type	Value
>Retrieve AE Title	(0008,0054)	2C	from Storage Commitment RSP or zero length (always zero length for autoarchiving)
>Referenced Image Sequence	(0008,1140)	2C	created
>>Referenced SOP Class UID	(0008,1150)	1C	
>>Referenced SOP Instance UID	(0008,1155)	1C	
>Referenced Standalone SOP Instance Sequence	(0040,0220)	2C	zero length
Radiation Dose			
Total Number of Exposures	(0040,0301)	3	created (number of scans)
Distance Source to Detector (SID)	(0018,1110)	3	created
Distance Source to Entrance	(0040,0306)	3	created
Comments on Radiation Dose	(0040,0310)	3	created (one line per scan) ^a
Billing and Material Management Code			
Film Consumption Sequence	(0040,0321)	3	created or zero length
>Number of Films	(2100,0170)	3	
>Medium Type	(2000,0030)	3	
>Film Size ID	(2010,0050)	3	



Performed Procedure Step N-SET Attributes			
Attribute name	Tag	Required Type	Value
Billing Supplies and Devices Sequence	(0040,0324)	3	user input in Examination Card (example values below) or MPPS window
>Billing Item Sequence	(0040,0296)	3	
>>Code Value	(0008,0100)	1C	e.g. contrast media code
>>Code Scheme Designator	(0008,0102)	1C	e.g. contrast media catalog
>>Code Meaning	(0008,0104)	1C	e.g. contrast media name
>Quantity Sequence	(0040,0293)	1C	
>>Quantity	(0040,0294)	3	e.g. volume of contrast media
>>Measuring Units Sequence	(0040,0295)	3	
>>>Code Value	(0008,0100)	1C	e.g. cm3
>>>Code Scheme Designator	(0008,0102)	1C	e.g. UCUM
>>>Code Scheme Version	(0008,0103)	1C	e.g. 1.4
>>>Code Meaning	(0008,0104)	1C	e.g. cm3

a. The following format is used:

RangeName: kV=xxx mAs=xxx CTDIw=xxx DLP=xxx

CTDIw and DLP is not provided for Topogram and CareVision scans.

Status Codes of the Performed Procedure Step N-SET

The Performed Procedure Step SCU interprets the following status values:

N-SET Response Status		
Service Status	Meaning	Status Codes (0000,0900)
Failure	Processing Failure: Performed Procedure Step Object may no longer be updated	0110
	No such attribute	0105
	Invalid attribute value	0106
	No such SOP Instance	0112
	Invalid object instance	0117
	No such SOP class	0118
	Class instance conflict	0119
	Missing attribute value	0121
	Resource limitation	0213
Success	Successful Operation	0000



Supported Communication Stacks

The Somaris/5 DICOM application provides DICOM V3.0 TCP/IP Network Communication Support as defined in Part 8 of the DICOM Standard.

OSI Stack

Not supported.

TCP/IP Stack

The Somaris/5 DICOM application uses the TCP/IP stack from the Windows NT system. It uses the MergeCOM-3 subroutine library from Merge Technologies Inc. that is based on a TCP/IP socket interface.

API

The Somaris/5 DICOM application uses the MergeCOM library that is based on a TCP/IP socket interface.

Physical Media Support

The Somaris/5 DICOM application is indifferent to the physical medium over which TCP/IP executes.

Point-to-Point Stack

Not supported.



Standard Extensions

Standard Extensions of all SOP Classes

The following tables list the data dictionary of all DICOM IOD attributes where the DICOM standard definitions are extended:

Attribute Name	Tag	Private Creator	Type	Notes
Image Type	(0008,0008)	-	1	<p>see → page A.4–3, Image Type additional Defined Terms:</p> <p>Defined Terms for value 3: OTHER MPR PROJECTION IMAGE UNDEFINED</p> <p>Defined Terms for value 4: CSA ^{*a} CT_SOM4 * CT_SOM5 ^{*b} CT_SOM6 * SHS *</p> <p>Somaris/5 based SOMATOM products provide a value 5 with the Defined Terms: ADD CTL FINISHED IN_WORK MRTD OTOM OTOP PBF PBV PKET PMON TTP TTS</p>

Attribute Name	Tag	Private Creator	Type	Notes
Patient Position	(0018,5100)	-	2C	Additional Defined Terms for the Magnetom Open: HLS HLP FLS FLP HLDL HLDR FLDL FLDR see → page A.4–9, Patient Position for further explanation
Body Part Examined	(0018,0015)		3	Defined Terms for the Somaris/5 based SOMATOM products: SPINE SPECIAL UNKNOWN SERVICE see → page A.4–9, Body Part Examined for further explanation

a. For terms beginning with the stated prefix, e. g. "CSA", and ending with a "***" see → page A.4–3, Image Type.

b. For private extensions see → page A.4–26, Private Elements for Storage SOP Classes.

All SOP classes may contain additional type 3 attributes which DICOM standard defines in a different DICOM IOD or DICOM SOP class (attributes from Normalized SOP classes).

This is the case for example for

- Rescale Slope (0028,1053)
- Rescale Intercept (0028,1052)

which are also used in the MR IOD.

Image Type

The Image Type (0008,0008) attribute identifies important image identification characteristics. These characteristics are:

1. Pixel Data Characteristics:
 - Is the image an ORIGINAL Image; an image whose pixel values are based on original or source data, or
 - is the image a DERIVED Image; an image whose pixel values have been derived in some manner from the pixel value of one or more other images.
2. Patient Examination Characteristics:
 - Is the image a PRIMARY Image; an image created as a direct result of the Patient examination, or
 - is the image a SECONDARY Image; an image created after the initial Patient examination.
3. Modality Specific Characteristics (SOP Specific Characteristics).
4. Implementation specific identifiers; other implementation specific identifiers shall be documented in an implementation's conformance claim.

The Image Type attribute is multi-valued and shall be provided in the following manner:

- Value 1 shall identify the Pixel Data Characteristics; Enumerated Values for the Pixel Data Characteristics are:
 - ORIGINAL = identifies an Original Image
 - DERIVED = identifies a Derived Image
- Value 2 shall identify the Patient Examination Characteristics; Enumerated Values for the Patient Examination Characteristics are:
 - PRIMARY = identifies a Primary Image
 - SECONDARY = identifies a Secondary Image
- Value 3 shall identify any Image IOD specific specialization, the following terms are defined in addition to the DICOM standard definitions:
 - OTHER = converted non-Axial and non-Localizer CT images; images of no special type (new syntax)

- ❑ MPR = 3D MPR images (MR)
- ❑ PROJECTION IMAGE = 3D MIP and SSD images (MR)
- ❑ UNDEFINED = images of no special type (old syntax)

- ❑ **Value 4** is implementation specific. The following terms are defined:
 - ❑ original *syngo* generated data set types:
 - CSA 3D EDITOR** = object created by 3D Editor
 - CSA 3D FLY PATH** = object created by Fly Through Path
 - CSA 3D FLY VRT** = object created by Fly Through Volume Rendering Technique
 - CSA 3D FUSION** = object created by Fusion
 - CSA AVERAGE** = image was created by Average
 - CSA BLACK IMAGE** = SC Image with black pixels, only graphics information is of interest
 - CSA RESAMPLED** = derived image created by zooming or panning original image
 - CSA MIP** = image created by Maximum Intensity Projection
 - CSA MIP THIN** = image created by Maximum Intensity Projection
 - CSA MPR** = image created by Multi Planar Reconstruction
 - CSA MPR CURVED** = image created by Multi Planar Reconstruction
 - CSA MPR THICK** = image created by Multi Planar Reconstruction
 - CSA MPR THIN** = image created by Multi Planar Reconstruction
 - CSA SSD** = SC Image as Shaded Surface Display
 - CSA SUBTRACT** = image was created by Subtraction
 - ECAT ACF** = CTI PET Attenuation Correction
 - ECAT NORMAL** = CTI PET Normalization
 - ECAT 3D SINO** = CTI PET 3D Sinogram Short
 - ECAT 3D SINO FLT** = CTI PET 3D Sinogram Float
 - ❑ additional image types generated by Somaris/5 based SOMATOM products:
 - CT_SOM5 AVE** = Average Image
 - CT_SOM5 ICD** = Interventional Cine Display Image
 - CT_SOM5 MON** = Monitoring Image

- CT_SOM5 MUL** = Multiscan Image
- CT_SOM5 PAR** = Parameter Image
- CT_SOM5 PROT** = Protocol Image
- CT_SOM5 ROT** = ROT Image
- CT_SOM5 RTD** = Real Time Display Image
- CT_SOM5 SEQ** = Sequence Image
- CT_SOM5 SPI** = Spiral Image
- CT_SOM5 STA** = Static Image
- CT_SOM5 SUB** = Subtracted Image
- CT_SOM5 TOP** = Topogram
- CT_SOM5 DPAN** = Dental Panorama Rebuilt Tomogram
- CT_SOM5 DPAR** = Dental Paraxial Rebuilt Tomogram
- CT_SOM5 DFLM** = Dental Filming Image
- CT_SOM5 DYB** = Dynamic Evaluation Averaged Baseline Image
- CT_SOM5 DYF** = Dynamic Evaluation Fused Multislice Image
- CT_SOM5 PEVI** = Pulmo Evaluation Image
- CT_SOM5 OEVA** = Osteo Evaluated Tomogram
- CT_SOM5 MIP** = Maximum Intensity Projection image created by a CT application
- CT_SOM5 MPR** = Multi Planar Reconstruction image created by a CT application
- CT_SOM5 REP** = Lung Care Report Image
- converted images
 - CT_SOM4 NONE** = converted SOMARIS image
 - CT_SOM4 CONV** = converted SOMARIS Convolution Kernel file
 - CT_SOM4 DART** = converted SOMARIS Dental Artificial image
 - CT_SOM4 DEVA** = converted SOMARIS Dental Evaluation image
 - CT_SOM4 DGRA** = converted SOMARIS Dental Graphics image
 - CT_SOM4 DMEA** = converted SOMARIS Dynamic Measurement image
 - CT_SOM4 DPAN** = converted SOMARIS Dental Panorama image
 - CT_SOM4 DPAR** = converted SOMARIS Dental Paraxial image

CT_SOM4 EBT = converted SOMARIS Evolution image
CT_SOM4 HIS = converted SOMARIS Histogram Graphics image
CT_SOM4 HISC = converted SOMARIS Histogram Graphics image
CT_SOM4 MUL = converted SOMARIS Multiscan image
CT_SOM4 OEVA = converted SOMARIS Osteo Evaluation image
CT_SOM4 OTOM = converted SOMARIS Osteo Tomogram image
CT_SOM4 OTOP = converted SOMARIS Osteo Topogram image
CT_SOM4 PLOT = converted SOMARIS Plot image
CT_SOM4 QUAL = converted SOMARIS Quality image
CT_SOM4 R2D = converted SOMARIS 2D Rebuild image
CT_SOM4 R3D = converted SOMARIS 3D Rebuild image
CT_SOM4 R3DE = converted SOMARIS 3D Rebuild image
CT_SOM4 RMAX = converted SOMARIS Maximum Intensity Projection image
CT_SOM4 RMIN = converted SOMARIS Minimum Intensity Projection image
CT_SOM4 ROT = converted SOMARIS Rotation Mode image
CT_SOM4 RRAD = converted SOMARIS Radiographic Projection image
CT_SOM4 RVIT = converted SOMARIS Vessel Image Tool image
CT_SOM4 RVRT = converted SOMARIS Volumetric Rendering image
CT_SOM4 SAVE = converted SOMARIS Evolution Screen Save image
CT_SOM4 SCAN = converted SOMARIS Standard Mode image
CT_SOM4 SEQ = converted SOMARIS Sequence Mode image
CT_SOM4 SER = converted SOMARIS Serial Mode image
CT_SOM4 SIN = converted SOMARIS Sinogram image

CT_SOM4 SINC = converted SOMARIS Sinogram image

CT_SOM4 SPI = converted SOMARIS Spiral Mode image

CT_SOM4 STA = converted SOMARIS Static Mode image

CT_SOM4 TAB = converted SOMARIS Correction Table image

CT_SOM4 TOP = converted SOMARIS Topogram image

CT_SOM4 GTOP = converted SOMARIS Topo Graphics image

CT_SOM4 PEVG = converted SOMARIS Pulmo Evaluation image

CT_SOM4 PEVI = converted SOMARIS Pulmo Evaluation image

CT_SOM4 PUL = converted SOMARIS Pulmo Respiration curve

CT_SOM4 PROT = converted SOMARIS Protocol image

CT_SOM4 TEXT = converted SOMARIS Text image

CT_SOM4 ICD = converted SOMARIS Interventional Cine image

SHS DENT = converted MagicView Dental Tomogram image

SHS DPAN = converted MagicView Dental Panorama image

SHS DPAR = converted MagicView Dental Paraxial image

SHS 3D_CURVED = converted MagicView image

SHS 3D_MIP = converted MagicView Maximum Intensity Projection image

SHS 3D_MPR = converted MagicView Multi Planar Reconstruction image

SHS 3D_SSD = converted MagicView Shaded Surface Display image

SHS 3D_VRT = converted MagicView Volumetric Rendering image

- **Value 5** is specific for the Somaris/5 based SOMATOM products. The following terms are defined:

ADD = Additional Scan

CTL = Control Scan

FINISHED = Lung Care Report Image (finished)

IN_WORK = Lung Care Report Image (not finished)

MRTD = Multiscan Real Time Display Image

OTOM = Osteo Scanned Tomogram
OTOP = Osteo Scanned Topogram
PBF = Perfusion Blood Flow Image
PBV = Perfusion Blood Volume Image
PKET = Peak Enhancement Parameter Image
PMON = Premonitoring Scan
TTP = Time to Peak Parameter Image
TTS = Time to Start Parameter Image

Patient Position

The Patient Position attribute (0018,5100) defines the patient position relative to the equipment.

The Defined Terms for this value were extended for the MAGNETOM OPEN product. Here the patient is not positioned HeadFirst/FeetFirst when facing the front of the imaging equipment but HeadLeft or FeetLeft.

The new values are:

- HLS** (Head left - Supine)
- HLP** (Head left - Prone)
- FLS** (Feet left - Supine)
- FLP** (Feet left - Prone)
- HLDL** (Head left - Decubitus left)
- HLDR** (Head left - Decubitus right)
- FLDL** (Feet left - Decubitus left)
- FLDR** (Feet left - Decubitus right)

Body Part Examined

The Body Part Examined (0018,0015) attribute provides a textual description of the part of the body examined. The Somaris/5 based SOMATOM products extend the Defined Terms:

- SPINE** = Summary term used instead of the Defined Terms CSPINE, TSPINE, LSPINE, and SSPINE
- SPECIAL** = Image was acquired with acquisition modes that are not mapped to a certain part of the body
- SERVICE** = Image was acquired for maintenance purpose
- UNKNOWN** = No information about the body part available

See → page A.4–16, *Somaris/5 Attribute Interpretation* for a mapping of the organ characteristics used for examination to the Body Part Examined terms.

RGB color images

The Somaris/5 DICOM application extends the CT Image IOD by the use of RGB color image description with the unsigned integer 24 bit color image plane pixel format:

- samples per pixel (attribute 0028, 0002) = 3
- photometric interpretation (attribute 0028,0004) = "RGB"
- pixel representation (attribute 0028, 0103) = 0
- bits allocated (attribute 0028, 0100) = 8
- bits stored (attribute 0028,0101) = 8
- high bit (attribute 0028,0102) = 7
- planar configuration (attribute 0028,0006) = 0

This format is used for Functional Imaging, i.e. images that meaningfully use all common CT Image attributes - however the pixel values do not represent a scaled Hounsfield value but a different value (depending on the type of image). Thus window related attributes must not be used to interpret the pixel values as scaled HU. The values used by Somaris/5 are:

- window center (attribute 0028, 1050) = 128
- window width (attribute 0028,1051) = 256
- rescale intercept (attribute 0028, 1050) = 0
- rescale slope (attribute 0028,1051) = 1

The following types of images may use this format:

Somaris/5 Image Type (0008,0008) for objects <u>created</u> by Somaris/5							
Image Type Description	IOD	0008,0008 Value 1	0008,0008 Value 2	0008,0008 Value 3	0008,0008 Value 4	0008,0008 Value 5	Somaris/5 Image Text
Averaged Image	CT	DERIVED	SECONDARY	AXIAL	CT_SOM5 AVE	none	AVE
Parameter Image (Peak enhancement)	CT	DERIVED	SECONDARY	AXIAL	CT_SOM5 PAR	PKET	PAR
Parameter Image (Perfusion Blood Flow)	CT	DERIVED	SECONDARY	AXIAL	CT_SOM5 PAR	PBF	PAR
Parameter Image (Perfusion Blood Volume)	CT	DERIVED	SECONDARY	AXIAL	CT_SOM5 PAR	PBV	PAR
Parameter Image (Time to Peak)	CT	DERIVED	SECONDARY	AXIAL	CT_SOM5 PAR	TTP	PAR
Parameter Image (Time to Start)	CT	DERIVED	SECONDARY	AXIAL	CT_SOM5 PAR	TTS	PAR
Volume Maximum Intensity Projection Image	CT	DERIVED	SECONDARY	AXIAL	CT_SOM5 MIP	none	MIP

Specializations

Images created by Somaris/5

The following table lists the Somaris/5 image types and the corresponding combinations of the Image Type Attribute values:

Image Type Description [known creating applications]	IOD	0008,0008 Value 1	0008,0008 Value 2	0008,0008 Value 3	0008,0008 Value 4	0008,0008 Value 5	Somaris/5 Image Text
Averaged Image [Average, DynEva, Perfusion]	CT	DERIVED	SECONDARY	AXIAL	CT_SOM5 AVE	none	AVE
Interventional Cine Display Image	CT	ORIGINAL	PRIMARY	AXIAL	CT_SOM5 ICD	none	ICD
Monitoring Image	CT	ORIGINAL	PRIMARY	AXIAL	CT_SOM5 MON	none	MON
Premonitoring Image	CT	ORIGINAL	PRIMARY	AXIAL	CT_SOM5 MON	PMON	MON
Multiscan Image	CT	ORIGINAL	PRIMARY	AXIAL	CT_SOM5 MUL	none	MUL
Parameter Image (Peak enhancement) [DynEva, Perfusion]	CT	DERIVED	SECONDARY	AXIAL	CT_SOM5 PAR	PKET	PAR
Parameter Image (Perfusion Blood Flow) [Perfusion]	CT	DERIVED	SECONDARY	AXIAL	CT_SOM5 PAR	PBF	PAR
Parameter Image (Perfusion Blood Volume) [Perfusion]	CT	DERIVED	SECONDARY	AXIAL	CT_SOM5 PAR	PBV	PAR



Image Type Description [known creating applications]	IOD	0008,0008 Value 1	0008,0008 Value 2	0008,0008 Value 3	0008,0008 Value 4	0008,0008 Value 5	Somaris/5 Image Text
Parameter Image (Time to Peak) [DynEva, Perfusion]	CT	DERIVED	SECONDARY	AXIAL	CT_SOM5 PAR	TTP	PAR
Parameter Image (Time to Start) [Perfusion]	CT	DERIVED	SECONDARY	AXIAL	CT_SOM5 PAR	TTS	PAR
Protocol Image	SC	DERIVED	SECONDARY	OTHER	CT_SOM5 PROT	none	PROT (List only)
Report Image (not finished)	SC	DERIVED	SECONDARY	OTHER	CT_SOM5 REP	IN_WORK	REP
Report Image (finished)	SC	DERIVED	SECONDARY	OTHER	CT_SOM5 REP	FINISHED	REP
ROT Image	CT	ORIGINAL	PRIMARY	AXIAL	CT_SOM5 ROT	none	ROT
Real Time Display Image	CT	ORIGINAL	PRIMARY	AXIAL	CT_SOM5 RTD	none	RTD
Multiscan Real Time Display Image	CT	ORIGINAL	PRIMARY	AXIAL	CT_SOM5 RTD	MRTD	RTD
Sequence Image	CT	ORIGINAL	PRIMARY / SECONDARY	AXIAL	CT_SOM5 SEQ	none	SEQ
Additional Scan Image	CT	ORIGINAL	PRIMARY / SECONDARY	AXIAL	CT_SOM5 SEQ	ADD	SEQ
Control Scan Image	CT	ORIGINAL	PRIMARY / SECONDARY	AXIAL	CT_SOM5 SEQ	CTL	SEQ
Spiral Image	CT	ORIGINAL	PRIMARY / SECONDARY	AXIAL	CT_SOM5 SPI	none	SPI
Static Image	CT	ORIGINAL	PRIMARY	OTHER	CT_SOM5 STA	none	STA

Image Type Description [known creating applications]	IOD	0008,0008 Value 1	0008,0008 Value 2	0008,0008 Value 3	0008,0008 Value 4	0008,0008 Value 5	Somaris/5 Image Text
Subtracted Image	CT	DERIVED	SECONDARY	AXIAL	CT_SOM5 SUB	none	SUB
Topogram	CT	ORIGINAL	PRIMARY	LOCALIZER	CT_SOM5 TOP	none	TOP
Osteo Scanned Tomogram	CT	ORIGINAL	PRIMARY	AXIAL	CT_SOM5 SEQ	OTOM	SEQ
Osteo Scanned Topogram	CT	ORIGINAL	PRIMARY	LOCALIZER	CT_SOM5 TOP	OTOP	TOP
Osteo Evaluated Tomogram	CT	DERIVED	SECONDARY	AXIAL	CT_SOM5 OEVA	none	OEVA
Pulmo Evaluated Tomogram	CT	DERIVED	SECONDARY	AXIAL	CT_SOM5 PEVI	none	PEVI
Dental Filming Image	SC	DERIVED	SECONDARY	OTHER	CT_SOM5 DFLM	none	DFLM
Dental Panorama Rebuild Tomogram	SC	DERIVED	SECONDARY	OTHER	CT_SOM5 DPAN	none	DPAN
Dental Paraxial Rebuild Tomogram	SC	DERIVED	SECONDARY	OTHER	CT_SOM5 DPAR	none	DPAR
Dental/Volume Maximum Intensity Projection Image [Dental, Volume, DynEva, Perfusion]	CT	DERIVED	SECONDARY	AXIAL	CT_SOM5 MIP	none	MIP
Dental Panorama Reference Image [Dental, Volume]	CT	DERIVED	SECONDARY	AXIAL	CT_SOM5 MPR	none	MPR
Dental Paraxial Reference Image	CT	DERIVED	SECONDARY	AXIAL	CT_SOM5 MPR	none	MPR



Image Type Description [known creating applications]	IOD	0008,0008 Value 1	0008,0008 Value 2	0008,0008 Value 3	0008,0008 Value 4	0008,0008 Value 5	Somaris/5 Image Text
Dental Reference Image	CT	DERIVED	SECONDARY	AXIAL	CT_SOM5 MPR	none	MPR
Dynamic Evaluation Averaged Baseline	CT	DERIVED	SECONDARY	AXIAL	CT_SOM5 DYB	none	DYB
Dynamic Evaluation Fused Multislice	CT	DERIVED	SECONDARY	AXIAL	CT_SOM5 DYF	none	DYF
Volume reformatted images (sagittal and coronal)	CT	DERIVED	SECONDARY	OTHER	CT_SOM5 MPR	none	MPR
Various result images [CalciumScoring, VesselView]	CT	DERIVED	SECONDARY	AXIAL	CSA MPR	none	MPR
Various result images [VesselView]	CT	DERIVED	SECONDARY	AXIAL	CSA MPR THICK	none	MPR
Various result images [VesselView]	CT	DERIVED	SECONDARY	AXIAL	CSA MIP	none	MIP
Various result images [CalciumScoring, VesselView]	CT	DERIVED	SECONDARY	AXIAL	CSA MIP THIN	none	MIP
Various result images [VesselView]	CT	DERIVED	SECONDARY	AXIAL	CSA VRT	none	VRT
Various result images [VesselView]	CT	DERIVED	SECONDARY	AXIAL	CSA RIBBON	none	RIBB
Various Graphics [DynEva, Osteo, Pulmo, Volume, Perfusion, Argus, VesselView]	SC	DERIVED	SECONDARY	OTHER	CSA BLACK IMAGE	none	none

Somaris/5 Attribute Interpretation

The following table lists how common attributes of created and uncompressed ORIGINAL and AXIAL images are set by Somaris/5 image reconstruction. This table does not intend to be a substitute for DICOM 3.0 attribute definitions. However, in addition to these it will provide an impression of which attributes are in common use - and how they are related to Somaris/5 examination:

Tag	Name	Explanation
0002,0012	Implementation Class UID	Value: 1.3.12.2.1107.5.1.4
0002,0013	Implementation Version Name	Value: SIEMENS_S5VA45C
0008,0005	Specific Character Set	see chapters A.6 and B.6
0008,0008	Image Type	see → page A.4–12, Images created by Somaris/5
0008,0016	SOP Class UID	Value: 1.2.840.10008.5.1.4.1.1.2
0008,0018	SOP Instance UID	created
0008,0020	Study Date	For existing studies their date and time entries are copied into the corresponding entries in a new image's header. If a new study is created the date and time entries from the first series of this new study will be used.
0008,0030	Study Time	
0008,0021	Series Date	For existing series their date and time entries are copied into the corresponding entries in a new image's header. If a new series is created the current real-world date and time will be used.
0008,0031	Series Time	



Tag	Name	Explanation
0008,0022	Acquisition Date	Acquisition Date and Time is defined as the real-world beginning of the accumulation of data which contribute to a particular image. Due to the multi-slice technology several images may have the same Acquisition Date and Time.
0008,0032	Acquisition Time	
0008,0023	Image (Content) Date	<p>For all images which result from a reconstruction of acquired data, the time stamp is the same as Acquisition Date and Time. This is true for images that were reconstructed immediately after data acquisition as well as for images that were reconstructed at any time later.</p> <p>For all other images created by any other means the time stamp is derived from a point in time during the creation process of these images.</p>
0008,0033	Image (Content) Time	
0008,0050	Accession Number	Input entered from MWL or during patient registration. May be null-length.
0008,0060	Modality	Value: CT
0008,0070	Manufacturer	Value: SIEMENS
0008,0080	Institution Name	Hospital name read from configuration data or user input entered during patient registration or examination setup.
0008,0081	Institution Address	Hospital address read from configuration data. Default format is 4 lines containing Street, City, District and Country.
0008,0090	Referring Physician's Name	Input from MWL or entered during patient registration or examination setup. May be null-length.
0008,1010	Station Name	Name of the computer the examination is controlled with.

Tag	Name	Explanation
0008,1030	Study Description	Is derived from information entered during patient registration or examination setup. Concatenated from Body Region and selected Scan Protocol name, separated by a "^"
0008,1050	Performing Physician's Name	Input entered from MWL or during patient registration.
0008,1070	Operator's Name	According to user input
0008,1080	Admitting Diagnoses Description	Input entered from MWL or during patient registration.
0008,103E	Series Description	Is derived from the parameters of the data acquisition and reconstruction process.
0008,1090	Manufacturer's Model Name	The Siemens product name
0008,1140	Referenced Image Sequence	
0008,1150	Referenced SOP Class UID	SOP Class UID of Topogram used for planning
0008,1155	Referenced SOP Instance UID	SOP Instance UID of Topogram used for planning
0008,1140	Source Image Sequence	
0008,1150	Referenced SOP Class UID	SOP Class UID of Rawdata used for reconstruction
0008,1155	Referenced SOP Instance UID	SOP Instance UID of Rawdata used for reconstruction
0008,1155	Referenced SOP Instance UID	SOP Instance UID of Rawdata used for reconstruction
0009,00xx	Private Creator	Value: SIEMENS CT VA1 DUMMY
0010,0010	Patient's Name	Input from MWL or entered during patient registration or examination setup.



Tag	Name	Explanation
0010,0020	Patient ID	Input from MWL or entered or generated during patient registration or examination setup.
0010,0030	Patient's Birth Date	Input from MWL or entered during patient registration or examination setup. May be calculated from age.
0010,0040	Patient's Sex	Input from MWL or entered during patient registration or examination setup.
0010,1010	Patient's Age	Input from MWL or entered during patient registration or examination setup. May be calculated from Patient's Birth Date.
0018,0010	Contrast/Bolus Agent	<p>If present: For images created during an acquisition: The attribute is filled with the value entered during scan setup.</p> <p>For images created by a subsequent reconstruction after acquisition: The attribute is filled with the fixed term "APPLIED" if contrast/bolus agent information was entered during scan setup.</p>

Tag	Name	Explanation																						
0018,0015	Body Part Examined	<p>The Body Part Examined is derived from the organ characteristic of the scan. This parameter is contained in the scan protocol selected for examination during patient registration or examination setup and may vary for different scans within one protocol (use System/Run/List Scan Protocols column "OrgChar" for a list of values for specific scan protocols).</p> <p>Organ Characteristic Body Part Examined</p> <table> <tr><td>Head</td><td>HEAD</td></tr> <tr><td>Neck</td><td>NECK</td></tr> <tr><td>Shoulder</td><td>SHOULDER</td></tr> <tr><td>Thorax</td><td>CHEST</td></tr> <tr><td>Abdomen</td><td>ABDOMEN</td></tr> <tr><td>Spine</td><td>SPINE</td></tr> <tr><td>Pelvis</td><td>PELVIS</td></tr> <tr><td>Extremities</td><td>EXTREMITY</td></tr> <tr><td>Cardio</td><td>HEART</td></tr> <tr><td>Service</td><td>SERVICE</td></tr> <tr><td>n. a.</td><td>UNKNOWN</td></tr> </table>	Head	HEAD	Neck	NECK	Shoulder	SHOULDER	Thorax	CHEST	Abdomen	ABDOMEN	Spine	SPINE	Pelvis	PELVIS	Extremities	EXTREMITY	Cardio	HEART	Service	SERVICE	n. a.	UNKNOWN
Head	HEAD																							
Neck	NECK																							
Shoulder	SHOULDER																							
Thorax	CHEST																							
Abdomen	ABDOMEN																							
Spine	SPINE																							
Pelvis	PELVIS																							
Extremities	EXTREMITY																							
Cardio	HEART																							
Service	SERVICE																							
n. a.	UNKNOWN																							
0018,0050	Slice Thickness	Resulting slice thickness. Not necessarily equal to collimated slice.																						
0018,0060	KVP	Voltage selected for scan.																						
0018,1020	Software Version(s)	Software Version of Somaris/5. Only one value is used.																						
0018,1030	Protocol Name	Name of Scan Protocol selected during patient registration or examination setup.																						
0018,1100	Reconstruction Diameter	Field of View selected for reconstruction																						
0018,1110	Distance Source to Detector																							
0018,1111	Distance Source to Patient																							
0018,1120	Gantry/Detector Tilt																							
0018,1130	Table Height	Table height as entered for scan																						

Tag	Name	Explanation
0018,1140	Rotation Direction	
0018,1150	Exposure Time	The exposure time for the respective image. For spiral scan or multiscan this corresponds to the rotation time.
0018,1151	X-ray Tube Current	Tube current used for scanning.
0018,1152	Exposure	(Effective) mAs. For spiral images the product of exposure time and x-ray tube current is corrected with Table Feed per Rotation. Expressed in mAs.
0018,1160	Filter Type	0: No Filter, 1: Teflon Filter
0018,1170	Generator Power	
0018,1190	Focal Spots	Size of the focal spot actually used to generate x-ray radiation for a particular image. This is a single value expressed in mm.
0018,1200	Date of Last Calibration	Date of last Base Calibration
0018,1201	Time of Last Calibration	Time of last Base Calibration
0018,1210	Convolution Kernel	4 character code of convolution kernel
0018,5100	Patient Position	As entered for scan
0019,00xx	Private Creator	Value: SIEMENS CT VA0 COAD
0019,xxB0	Feed per Rotation	Movement of table during one rotation in mm.
0020,000D	Study Instance UID	From MWL or created
0020,000E	Series Instance UID	From MWL or created
0020,0010	Study ID	From MWL or created
0020,0011	Series Number	created
0020,0012	Acquisition Number	Scan number within this examination.
0020,0013	Instance Number	created; direction within range selectable by user

Tag	Name	Explanation
0020,0032	Image Position (Patient)	The x, y, and z coordinates of the center of the first pixel, in mm.
0020,0037	Image Orientation (Patient)	
0020,0052	Frame of Reference UID	created
0020,1040	Position Reference Indicator	null-length
0020,1041	Slice Location	Topogram: Slice Location is defined as the relative table position of the very beginning of the Topogram image expressed in mm. Tomogram: Slice Location is defined as the relative position of the intersection of the image's slice with the z-axis expressed in mm. This positions is relative to the current reference point and corresponds to the table position.
0020,4000	Image Comments	According to user input. 2 lines supported.
0021,00xx	Private Creator	Value: SIEMENS MED
0021,xx11	Target	Center x/y as entered for reconstruction
0028,0002	Samples per Pixel	Value: 1
0028,0004	Photometric Interpretation	Value: MONOCHROME2
0028,0010	Rows	
0028,0011	Columns	
0028,0030	Pixel Spacing	
0028,0100	Bits Allocated	Value: 16
0028,0101	Bits Stored	Value: 12
0028,0102	High Bit	Value: 11
0028,0103	Pixel Representation	Value: 0

Tag	Name	Explanation
0028,1050	Window Center	Last windowing center saved. First window followed by second window.
0028,1051	Window Width	Last windowing width saved. First window followed by second window.
0028,1052	Rescale Intercept	Value -1024 for images without extended CT scale
0028,1053	Rescale Slope	Value 1 for images without extended CT scale
0028,1055	Window Center & Width Explanation	Value: "WINDOW1", "WINDOW2"
0029,xxxx	(private data)	see → page A.4–26, Privatisations
0032,1060	Requested Procedure Description	Input entered during patient registration or examination setup.
7FE0,0010	Pixel Data	

OOG, Overlays, High Bits

Graphics in Somaris/5 images are stored as Object Oriented Graphics (OOG) in private attributes (see → page A.4–33). Non *syngo* based systems are not expected to interpret this information.

In order to allow display access to graphics information for DICOM based systems private OOG information is converted on export into DICOM Overlay information stored in group 6000. This is the recommended way for a DICOM based system to access overlay graphics information.

The following attributes are generated:

- Overlay Rows (6000,0010)
- Overlay Columns (6000,0011)
- Number of Frames in Overlay (6000,0015)
- Overlay Description (6000,0022) = "Siemens MedCom Object Graphics"
- Overlay Type (6000,0040) = "G"
- Origin (6000,0050) = 1, 1
- Image Frame Origin (6000,0051)
- Overlay Bits Allocated (6000,0100)
- Bit Position (6000,0102)
- Overlay Data (6000,3000)

However, DICOM Overlay information stored in group 6000 is not supported by all systems that might be used to store Somaris/5 images. These systems may not be able to display Somaris/5 generated overlays. For a special group of these systems there is another way to provide graphical overlay information. A remote node can be configured to have overlay graphics converted into unused pixel data above High Bit (0028,0102) for images that fulfil the following condition:

- bits allocated (attribute 0028, 0100) = 16
- bits stored (attribute 0028,0101) = 12
- high bit (attribute 0028,0102) = 11

Some systems are known to support this coding; they are able to display this information with the images. Please note, however, that the proper and recommended way to store overlays with DICOM is the use of group 6000.

Privatisations

Private Elements for Storage SOP Classes

The following private attributes are defined for all Siemens *syngo* based applications:

Registry of DICOM Data Elements

Tag	Private Owner Code	Name	VR	VM
(0029,xx08)	SIEMENS CSA HEADER	CSA Image Header Type	CS	1
(0029,xx09)	SIEMENS CSA HEADER	CSA Image Header Version	LO	1
(0029,xx10)	SIEMENS CSA HEADER	CSA Image Header Info	OB	1
(0029,xx18)	SIEMENS CSA HEADER	CSA Series Header Type	CS	1
(0029,xx19)	SIEMENS CSA HEADER	CSA Series Header Version	LO	1
(0029,xx20)	SIEMENS CSA HEADER	CSA Series Header Info	OB	1
(0029,xx08)	SIEMENS CSA NON-IMAGE	CSA Data Type	CS	1
(0029,xx09)	SIEMENS CSA NON-IMAGE	CSA Data Version	LO	1
(0029,xx10)	SIEMENS CSA NON-IMAGE	CSA Data Info	OB	1
(0029,xx08)	SIEMENS MEDCOM HEADER	MedCom Header Type	CS	1
(0029,xx09)	SIEMENS MEDCOM HEADER	MedCom Header Version	LO	1
(0029,xx10)	SIEMENS MEDCOM HEADER	MedCom Header Info	OB	1
(0029,xx20)	SIEMENS MEDCOM HEADER	MedCom History Information	OB	1
(0029,xx31)	SIEMENS MEDCOM HEADER	PMTF Information 1	LO	1
(0029,xx32)	SIEMENS MEDCOM HEADER	PMTF Information 2	UL	1
(0029,xx33)	SIEMENS MEDCOM HEADER	PMTF Information 3	UL	1
(0029,xx34)	SIEMENS MEDCOM HEADER	PMTF Information 4	CS	1
(0029,xx35)	SIEMENS MEDCOM HEADER	PMTF Information 5	UL	1

Tag	Private Owner Code	Name	VR	VM
(0029,xx40)	SIEMENS MEDCOM HEADER	Application Header Sequence	SQ	1
(0029,xx41)	SIEMENS MEDCOM HEADER	Application Header Type	CS	1
(0029,xx42)	SIEMENS MEDCOM HEADER	Application Header ID	LO	1
(0029,xx43)	SIEMENS MEDCOM HEADER	Application Header Version	LO	1
(0029,xx44)	SIEMENS MEDCOM HEADER	Application Header Info	OB	1
(0029,xx50)	SIEMENS MEDCOM HEADER	Workflow Control Flags	LO	8
(0029,xx51)	SIEMENS MEDCOM HEADER	Archive Management Flag Keep Online	CS	1
(0029,xx52)	SIEMENS MEDCOM HEAD	Archive Management Flag Do Not Archive	CS	1
(0029,xx53)	SIEMENS MEDCOM HEADER	Image Location Status	CS	1
(0029,xx54)	SIEMENS MEDCOM HEADER	Estimated Retrieve Time	DS	1
(0029,xx55)	SIEMENS MEDCOM HEADER	Data Size of Retrieved Images	DS	1
(0029,xx08)	SIEMENS MEDCOM OOG	MEDCOM OOG Type	CS	1
(0029,xx09)	SIEMENS MEDCOM OOG	MEDCOM OOG Version	LO	1
(0029,xx10)	SIEMENS MEDCOM OOG	MEDCOM OOG Info	OB	1

Tag	Private Owner Code	Name	VR	VM
(7FE1,xx10)	SIEMENS CSA NON-IMAGE	CSA Data	OB	1

The next subsections will explain in which IODs these private data elements are used.

*All syngo Supported Image SOP Classes***Extended Image IOD
Module Table**

IE	Module	Reference	Usage	Note
Patient	Patient	part 3 C.7.1.1	M	
Study	General Study	part 3 C.7.2.1	M	
	Patient Study	part 3 C.7.2.2	U	
Series	General Series	part 3 C.7.3.1	M	
Equipment	General Equipment	part 3 C.7.5.1	U	
Image	General Image	part 3 C.7.6.1	M	
	Image Pixel	part 3 C.7.6.3	M	
	IOD specific modules	part 3 C.8.2.1	M/U	depends on the IOD
	CSA Image Header	→ page A.4–29, CSA Image Header Module	U	
	CSA Series Header	→ page A.4–29, CSA Series Header Module	U	
	MEDCOM Header	→ page A.4–30, MEDCOM Header Module	U	private <i>syngo</i> information
	MEDCOM OOG	→ page A.4–33, MEDCOM OOG Module	U	if object graphics is attached to image
	SOP Common	part 3 C.12.1	M	

CSA Image Header Module The table in this section contains private IOD Attributes that describe the CSA Image Header.

Attribute Name	Tag	Private Creator	Type	Notes
CSA Image Header Type	(0029,xx08)	SIEMENS CSA HEADER	1	CSA Image Header identification characteristics. Defined Terms: NUM 4 = NUMARIS/4 SOM 5 = Somaris/5
CSA Image Header Version	(0029,xx09)	SIEMENS CSA HEADER	3	Version of CSA Image Header Info (0029,xx10) format.
CSA Image Header Info	(0029,xx10)	SIEMENS CSA HEADER	3	Product dependent information.

CSA Series Header Module The table in this section contains private IOD Attributes that describe the CSA Series Header.

Attribute Name	Tag	Private Creator	Type	Notes
CSA Series Header Type	(0029,xx18)	SIEMENS CSA HEADER	1	CSA Series Header identification characteristics. Defined Terms: NUM 4 = NUMARIS/4 SOM 5 = Somaris/5
CSA Series Header Version	(0029,xx19)	SIEMENS CSA HEADER	3	Version of CSA Series Header Info (0029,xx20) format.
CSA Series Header Info	(0029,xx20)	SIEMENS CSA HEADER	3	Product dependent information.

MEDCOM Header Module The table in this section contains private IOD Attributes that describe MEDCOM Header.

Attribute Name	Tag	Private Creator	Type	Notes
MedCom Header Type	(0029,xx08)	SIEMENS MEDCOM HEADER	1C	MedCom Header identification characteristics. Defined Terms: MEDCOM 1 Required if MedCom Header Info (0029,xx10) present.
MedCom Header Version	(0029,xx09)	SIEMENS MEDCOM HEADER	2C	Version of MedCom Header Info (0029,xx10) format. Required if MEDCOM Header Info (0029,xx10) present.
MedCom Header Info	(0029,xx10)	SIEMENS MEDCOM HEADER	3	Manufacturer model dependent information. The value of the attribute MedCom Header Info (0029,xx10) can be build up in each user defined format.
MedCom History Information	(0029,xx20)	SIEMENS MEDCOM HEADER	3	MedCom defined Patient Registration history information. See → page A.4–33, MEDCOM History Information.
PMTF Information 1	(0029,xx31)	SIEMENS MEDCOM HEADER	3	Transformation Information
PMTF Information 2	(0029,xx32)	SIEMENS MEDCOM HEADER	3	Transformation Information
PMTF Information 3	(0029,xx33)	SIEMENS MEDCOM HEADER	3	Transformation Information
PMTF Information 4	(0029,xx34)	SIEMENS MEDCOM HEADER	3	Transformation Information
Application Header Sequence	(0029,xx40)	SIEMENS MEDCOM HEADER	3	Sequence of Application Header Items. Zero or more Items shall be included in this sequence. Encoded as a sequence of items.

Attribute Name	Tag	Private Creator	Type	Notes
>Application Header Type	(0029,xx41)	SIEMENS MEDCOM HEADER	1C	Application Header identification characteristics. Required if Sequence is sent.
>Application Header ID	(0029,xx42)	SIEMENS MEDCOM HEADER	3	Identification of an application header.
>Application Header Version	(0029,xx43)	SIEMENS MEDCOM HEADER	3	Version of Application Header Info (0029,xx43) format.
>Application Header Info	(0029,xx44)	SIEMENS MEDCOM HEADER	3	Application dependent information.
Workflow Control Flags	(0029,xx50)	SIEMENS MEDCOM HEADER	3	Eight free definable flags.
Archive Management Flag Keep Online	(0029,xx51)	SIEMENS MEDCOM HEADER	3	Flag to control remote archive management system to keep the image always online (also when already archived). Enumerated Values: 00 = remote control not required, 01 = keep image online.
Archive Management Flag Do Not Archive	(0029,xx52)	SIEMENS MEDCOM HEADER	3	Flag to control remote archive management system not to archive the related image. Enumerated Values: 00 = remote control not required, 01 = don't archive image.

Attribute Name	Tag	Private Creator	Type	Notes
Image Location Status	(0029,xx53)	SIEMENS MEDCOM HEADER	3	Image location status to control retrieving. Defined Terms: ONLINE = retrieving has to be done as usual, NEARLINE = move request to SCP and delay according to value of Estimated Retrieve Time (0029,xx54), OFFLINE = invoking a retrieve operation initiates an operator request, INVALID = invoking a retrieve operation would always result in an error.
Estimated Retrieve Time	(0029,xx54)	SIEMENS MEDCOM HEADER	3	Estimated retrieve time in seconds. A value less then zero (< 0) indicates location is OFFLINE or INVALID.
Data Size of Retrieved Images	(0029,xx55)	SIEMENS MEDCOM HEADER	3	Data size of images in MByte.

MEDCOM History Information

The value of the attribute MEDCOM History Information (0029,xx20) is defined in the following way:

Part	Name	Type	Bytes	Notes
header	Identifier	string	32	always "CSA HISTORY"
	Version	string	32	e.g. "V1.10"
n items	Class Name	string	64	
	Modification String	string	1024	

MEDCOM OOG Module

The table in this section contains private IOD Attributes that describe MEDCOM Object Oriented Graphics (OOG). This module is used when object graphics is drawn on the image and stores the properties of the graphics objects (Line, Circle, Rectangle, Arrow, and so on). So the graphics objects will remain re-animatable even if such an image is transferred via DICOM C-STORE SOP class.

Attribute Name	Tag	Private Creator	Type	Notes
MedCom OOG Type	(0029,xx08)	SIEMENS MEDCOM OOG	1	MEDCOM Object Oriented Graphics (OOG) identification characteristics. Defined Terms: MEDCOM OOG 1
MedCom OOG Version	(0029,xx09)	SIEMENS MEDCOM OOG	3	Version of MEDCOM OOG Info (0029,xx10) format.
MedCom OOG Info	(0029,xx10)	SIEMENS MEDCOM OOG	3	MEDCOM Object Oriented Graphics (OOG) data.

The graphics objects are also stored in one Image overlay plane for compatibility with other products which don't support the MedCom OOG module. Any system which does not support this MedCom OOG module has to remove these private attributes when modifying the image overlay data.

Private Elements for CT Image Storage SOP Classes

The following private attributes are defined by Somaris/5.

Registry of DICOM Data Elements

Tag	Private Owner Code	Name	VR	VM	Notes
(0019,xx90)	SIEMENS CT VA0 COAD	Osteo Offset	DS	1	Offset of the water equivalent material of the Siemens Osteo phantom to real water
(0019,xx92)	SIEMENS CT VA0 COAD	Osteo Regression Line Slope	DS	1	Slope of the regression line for the ESP (=European Spine Phantom) standardization
(0019,xx93)	SIEMENS CT VA0 COAD	Osteo Regression Line Intercept	DS	1	Intercept of the regression line for the ESP (= European Spine Phantom) standardization
(0019,xx96)	SIEMENS CT VA0 COAD	Osteo Phantom Number	IS	1	Number of the Siemens Osteo phantom
(0019,xxB0)	SIEMENS CT VA0 COAD	Feed per Rotation	DS	1	Som/4 style Feed per Rotation (Backwards Compatibility)
(0019,xxBD)	SIEMENS CT VA0 COAD	Pulmo Trigger Level	IS	1	Spirometer trigger level used for the scan, given in percent of VC (= Vital Capacity) of the patient

Tag	Private Owner Code	Name	VR	VM	Notes
(0019,xxBE)	SIEMENS CT VA0 COAD	Expiratoric Reserve Volume	DS	1	ERV (= Expiratoric Reserve Volume) achieved by the patient
(0019,xxBF)	SIEMENS CT VA0 COAD	Vital Capacity	DS	1	VC (= Vital Capacity) achieved by the patient
(0019,xxC0)	SIEMENS CT VA0 COAD	Pulmo Water	DS	1	Density of the water insert of the Siemens Pulmo phantom
(0019,xxC1)	SIEMENS CT VA0 COAD	Pulmo Air	DS	1	Density of the air holes of the Siemens Pulmo phantom
(0019,xxC2)	SIEMENS CT VA0 COAD	Pulmo Date	DA	1	Date of the evaluation of the Siemens Pulmo phantom
(0019,xxC3)	SIEMENS CT VA0 COAD	Pulmo Time	TM	1	Time of the evaluation of the Siemens Pulmo phantom
(0021xx11)	SIEMENS MED	Target	DS	2	Som/4 style Target (Backwards Compatibility)
(0009,00xx)	SIEMENS CT VA1 DUMMY	Private Creator Data Element	LO	1	1

Private SOP class CSA Non-Image

This chapter includes the definition of the Siemens AG B Med CSA defined private Non-Image Object (called CsaNonImage IOD). The focus of this private Non-Image Object is to address the requirement for non-image data sets found in *syngo* based applications.

The MedCom Non-Image Information Object Definition specifies data sets that are converted from a non-DICOM format to a modality independent DICOM format.

Examples of such manufacturer model dependent data sets are:

- Raw Data
- CT Admin Data
- MR Spectroscopy Data
- etc.

CSA Non-Image IOD Entity Relationship Model

The E-R model in [DICOM] A.1.2 depicts those components of the DICOM Information Model which directly refer to the CSA Non-Image IOD. The frame of reference IE, overlay IE, modality look up table IE, VOI lookup table IE and curve IE are not components of the CSA Non-Image IOD.

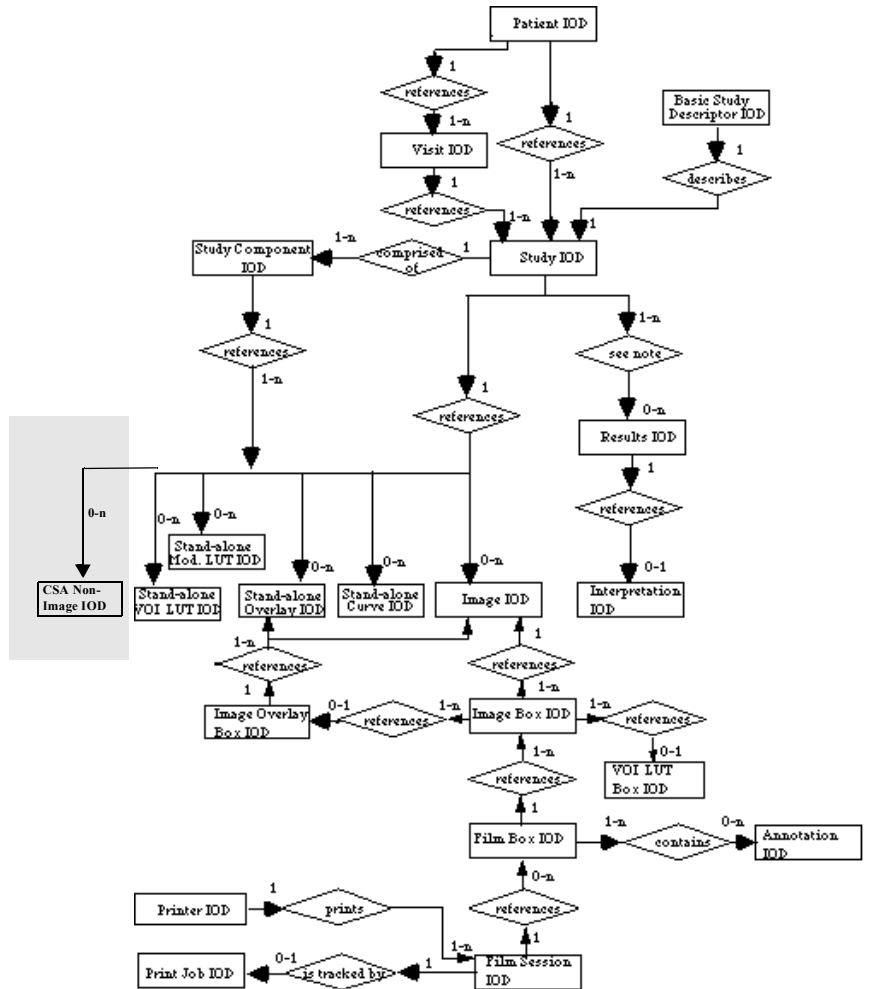

CSA Non-Image IOD Module Table

IE	Module	Reference	Usage
Patient	Patient	part 3 C.7.1.1	M
Study	General Study	part 3 C.7.2.1	M
	Patient Study	part 3 C.7.2.2	U
Series	General Series	part 3 C.7.3.1	M
Equipment	General Equipment	part 3 C.7.5.1	U
CSA	CSA Image Header	→ page A.4–29, CSA Image Header Module	U
	CSA Series Header	→ page A.4–29, CSA Series Header Module	U
	MEDCOM Header	→ page A.4–30, MEDCOM Header Module	U
	MEDCOM OOG	→ page A.4–33, MEDCOM OOG Module	U
	CSA Non-Image	→ page A.4–39, CSA Non-Image Module	M
	SOP Common	part 3 C.12.1	M

CSA Non-Image Module

The table in this section contains private IOD Attributes that describe CSA Non-Images.

Attribute Name	Tag	Private Creator	Type	Notes
Image Type	(0008,0008)	-	3	Image identification characteristics. See → page A.4–42, CT Extensions of the Non-Image Object
Acquisition Date	(0008,0022)	-	3	The date the acquisition of data that resulted in this data set started.
Acquisition Time	(0008,0032)	-	3	The time the acquisition of data that resulted in this data set started.
Conversion Type	(0008,0064)	-	3	Describes the kind of image conversion. Defined Terms: DV = Digitized Video, DI = Digital Interface, DF = Digitized Film, WSD = Workstation.
Referenced Image Sequence	(0008,1140)	-	3	A sequence which provides reference to a set of Image SOP Class/Instance identifying other images significantly related to this data set. Encoded as sequence of items: (0008,1150) and (0008,1155).
Derivation Description	(0008,2111)	-	3	A text description of how this data set was derived.
Source Image Sequence	(0008,2112)	-	3	A Sequence which identifies the set of Image SOP Class/Instance pairs of the Images which were used to derive this data set. Zero or more Items may be included in this Sequence. Encoded as sequence of items: (0008,1150) and (0008,1155).
Patient Position	(0018,5100)	-	3	Patient position descriptor relative to the equipment.

Attribute Name	Tag	Private Creator	Type	Notes
Acquisition Number	(0020,0012)	-	3	A number identifying the gathering of data over a period of time which resulted in this data set.
Image Number	(0020,0013)	-	3	A number that identifies this data set.
Frame of Reference UID	(0020,0052)	-	3	Uniquely identifies the frame of reference for a Series.
Image Comments	(0020,4000)	-	3	User-defined comments about the image.
Quality Control Image	(0028,0300)	-	3	Indicates whether or not this image is a quality control or phantom image. If this Attribute is absent, then the image may or may not be a quality control or phantom image. Enumerated Values: YES, NO.
Burned In Annotation	(0028,0301)	-	3	Indicates whether or not image contains sufficient burned in annotation to identify the patient and date the image was acquired. If this Attribute is absent, then the image may or may not contain burned in annotation. Enumerated Values: YES, NO.
Lossy Image Compression	(0028,2110)	-	3	Specifies whether an Image has undergone lossy compression. Enumerated Values: 00 = Image has NOT been subjected to lossy compression, 01 = Image has been subjected to lossy compression.
Lossy Image Compression Ratio	(0028,2112)	-	3	Describes the approximate lossy compression ratio(s) that have been applied to this image. May be multi valued if successive lossy compression steps have been applied.

Attribute Name	Tag	Private Creator	Type	Notes
CSA Data Type	(0029,xx08)	SIEMENS CSA NON-IMAGE	1	CSA Data identification characteristics. Defined Terms: RAW DATA NUM 4 = NUMARIS/4 Raw Data SPEC NUM 4 = NUMARIS/4 Spectroscopy RAW DATA SOM 5 = Somaris/5 Raw Data BSR REPORT = BSR Study Report Data
CSA Data Version	(0029,xx09)	SIEMENS CSA NON-IMAGE	3	Version of CSA Data Info (0029,xx10) format and CSA Non-Image Data (7FE1,xx10) format.
CSA Data Info	(0029,xx10)	SIEMENS CSA NON-IMAGE	3	Information to describe the CSA Data (7FE1,xx10). The value of the attribute CSA Data Info (0029,xx10) can be build up in each user defined format.
CSA Data	(7FE1,xx10)	SIEMENS CSA NON-IMAGE	2	Binary data as byte stream.

CT Extensions of the Non-Image Object

Somaris/5 uses the following defined term for Image Type (0008,0008):

- Value 1: ORIGINAL
- Value 2: PRIMARY
- Value 3: AXIAL, LOCALIZER, OTHER
- Value 4: a CT_SOM5 * enumeration
- Value 5: Somaris/5 specific enumeration

The following table lists the Somaris/5 non-image types and the corresponding combinations of the Image Type Attribute values.

Description	0008,0008 Value 1	0008,0008 Value 2	0008,0008 Value 3	0008,0008 Value 4	0008,0008 Value 5	Somaris/5 Image Text
ECG Data	none	none	none	none	none	none
Raw Data	Same entries as for images					

Private SOP Classes

SOP Class Name	SOP Class UID
CSA Non-Image	1.3.12.2.1107.5.9.1

Private Transfer Syntaxes

Not applicable.

AE Title / Presentation Address Mapping

To ensure unique identification the hostname should be part of the AE Titles, abbreviated AETs. The string can be up to 16 characters long and must not contain any extended characters, only 7 bit ASCII characters (excluding control characters) are allowed according to DICOM standard. An example name is HRI_station4.

Local AE Titles and Presentation Addresses

The local AE Titles can be configured using the Service application.

The following AETs can be configured:

- One common AET for Storage AE, Storage Commitment AE and Query/Retrieve AE.
- One AET for Modality Worklist AE and MPPS AE.
- One AET for Print AE.

Storage and Query/Retrieve SCP listen on port 104

Remote AE Titles and Presentation Addresses

For remote AETs, host names, IP addresses and port numbers can be configured using the Service application. For each AET a list of supported services can also be configured.

Configurable Parameters

Storage, Storage Commitment and Query Retrieve

The Service application can be used to set the AETs, port numbers, host names, IP addresses and capabilities for the remote nodes' (SCP's). The user can select transfer syntaxes, compression types and query models for each SCP separately.

Additional configurable parameters for Storage Commitment are:

When acting as SCU:

- Flag to indicate whether the association will be kept open to receive the response or to close the association and be prepared to receive the response on another association.
- Time-out which defines how long the association of N-ACTION is kept to receive a N-EVENT-REPORT on the same association.
- Time-out for N-EVENT-REPORT (applicability of transaction UID)
(default 1 h)
- A quality factor which determines the proposed transfer syntax in case that an user has initiated the C-STORE. By convention, 0 means: Only Uncompressed Transfer Syntax(es) are proposed, 100 means: Lossless Transfer Syntax is proposed, and any other value between 1 and 99 means that an JPEG Lossy Transfer Syntax is proposed. One Uncompressed Transfer Syntax will be proposed in any case. This parameter is general for all destination nodes.
- A "compression type supported" which determines the proposed transfer syntax in case that the C-STORE was initiated as a suboperation of an incoming C-MOVE-RQ. By convention, 0 means: Only Uncompressed Transfer Syntax(es) are proposed, 1 means: Lossless Transfer

Syntax is proposed, and 2 means that an JPEG Lossy Transfer Syntax is proposed. One uncompressed transfer syntax will be proposed in any case. This parameter can be set for each configured destination node.

When acting as SCP:

- flag to indicate if an archive system is installed

Print

The Service application can be used to configure the SCP. AET, host name, IP address, and port number can be set.

Modality Worklist

The Service application can be used to set the AETs, port numbers, host names, IP addresses, capabilities, and time-outs for the remote nodes (SCPs).

Additional configurable parameters for Basic Worklist Query are:

- Query Waiting time - the time to wait for the C-FIND-RSP after sending the C-FIND-RQ (default 20 s)
- Max. Query Match Number - the maximum number of entries accepted in one worklist (default is 100)
- Query Interval - the time between two C-FIND-RQs to the Hospital Information System (default is 60 min)
- Broad Worllist Query behaviour: two values are defined:
Set the AE Title search attribute to the own AE Title, and the Modality search attribute to "**".
Set the Modality search attribute to the own modality and the AE Title search attribute to "**".

Default Parameters

This configuration tool also uses some default parameters:

- maximal PDU size set to 28672 Bytes
- time-out for accepting/rejecting an association request: 60 s
- time-out for responding to an association open/close request: 60 s
- time-out for accepting a message over network: 60 s
- time-out for waiting for data between TCP/IP-packets: 60 s

The Time-outs for waiting for a Request/Response message from the remote node are as following:

- for Storage SCP/SCU: 600 s
- for Storage Commitment SCU:
 - time-out for Response to N-ACTION: 600 s
 - time-out for N-EVENT-REPORT: configurable, see → page A.5–2, *Configurable Parameters*.
- for Query/Retrieve SCP/SCU: 600 s
- for Modality Worklist SCU: configurable, see → page A.5–2, *Configurable Parameters*.
- for Print Management SCU:
 - time-out for Response to N-SET-RQ: 240 s
 - time-out for Response to other Requests: 60 s

The Somaris/5 DICOM application supports the ISO 8859 Latin 1 (ISO-IR 100) character set family and the same family with code extensions (ISO 2022 IR 100 Latin-1). For international versions the following character sets are supported:

- ❑ ISO_IR 13 Japanese (Katakana+Romaji) (JIS X 0201)
- ❑ ISO 2022 IR 13 Japanese (Katakana+Romaji)
- ❑ ISO 2022 IR 87 Kanji (JIS X 0208)
- ❑ ISO 2022 IR 159 Supplementary Kanji (JIS X 0212)

For the Chinese version the Chinese language character set GB2312 (ISO 2022 IR 58) is supported in a non-conforming way, combined with ISO 2022 IR 100 and ISO 2022 IR 87. If the product is operated in a DICOM networking environment, the user interface must be configured in a language using the ISO 8859 Latin 1 character set.

When there is a mismatch between the SCS tags (0008,0005) and the characters in an IOD coming into the system, then the following measures are taken to make the characters DICOM conform: Try to import with ISO-IR 100. If ISO-IR 100 also fails convert each illegal character to'?'.



Media Storage



Application Data Flow Diagram

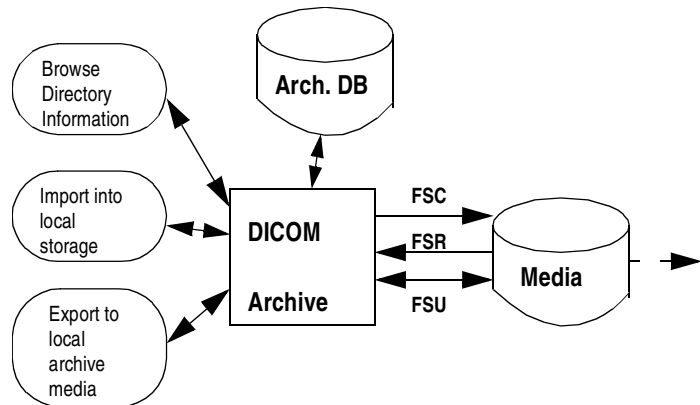

The DICOM archive application will serve as an interface to the CD-R or MOD off-line medium device. It serves interfaces to include the off-line media directory into the browser and to copy SOP instances to a medium or retrieve SOP Instances from medium into local storage.

The DICOM Archive application will support CD-R and MOD media (see table → page B.2-1).

The FSU role will update new SOP Instances only to media with pre-existing File-sets conforming to the Application Profiles supported.

The contents of the DICOMDIR will be temporarily stored in Archive-Database.

Functional definitions of AE's

The Somaris/5 DICOM off-line media storage application consists of the DICOM Archive application entity serving all interfaces to access off-line media. The DICOM Archive application is capable of

- ◇ creating a new File-set onto an unwritten medium
- ◇ updating an existing File-set by writing new SOP Instances onto the medium
- ◇ copying SOP Instances from the medium onto local storage
- ◇ reading the File-set's DICOMDIR information temporarily into database and pass it to display applications

Sequencing of Real-World Activities

The DICOM Archive application will not perform updates before the Directory information of the DICOMDIR is completely read.

File Meta Information Options

The Implementation Class UID is:

1.3.12.2.1107.5.1.4

and an Implementation Version Name of

"SIEMENS_S5VA45C"

DICOM Archive Specification

The DICOM Archive provides Standard conformance to Media Storage Service Class (Interchange Option).

Application Profiles Supported	Real World Activity	Role	SC Option
STD-GEN-CD	Browse Directory Information	FSR	Interchange
STD-CTMR-MOD650	Import into local Storage	FSR	Interchange
STD-CTMR-MOD12		FSR	Interchange
STD-CTMR-MOD23	Export to local archive media	FSC,FSU	Interchange
STD-CTMR-CD			
STD-XABC-CD			
STD-XA1K-CD			
TD-US-zz-yF-xxxxx ^a			
STD-WVFM-GEN-FD			

a. All combinations of the following values for zz, yF and xxxxx are supported:

'yF' can take two values: SF for Single Frame and MF for Multi Frame.

'zz' can take three values: ID (Image Display), SC(Spatial Calibration) and CC (Combined Calibration)

xxxxx can take 8 values: FLOP, MOD128, MOD230, MOD540, MOD650, MOD12, MOD23 and CDR

Configuration of uncompressed Transfer Syntax for export will result in compatibility to the STD-GEN-CD profile.

File Meta Information for the Application Entity

The Source Application Entity Title is set by configuration. See → Chapter B.5, *Configuration* for details.

Real-World Activities for this Application Entity

Real-World Activity: Browse Directory Information

The DICOM Archive application acts as FSR using the interchange option when requested to read the media directory.

The DICOM archive application will read the DICOMDIR and insert that directory entries, which are supported, into a local database. The database can then be used for browsing media contents.

Note

Icon Image SQ is also supported in DICOMDIR. But only those Icon Images with Bits Allocated (0028,0100) equal to 8 and size 64 by 64 or 128 by 128 pixels are imported into database and are visible in PatientBrowser.

Application Profiles for the RWA: Browse Directory Information

See table → page B.2–1 for the Application Profiles listed that invoke this Application Entity for the Browse Directory Information RWA.

**Application Profiles for the
RWA: Import into local
Storage***Real-World Activity: Import into local Storage*

The DICOM Archive application acts as FSR using the interchange option when requested to read SOP Instances from the medium into the local storage.

The SOP Instance selected from the media directory will be copied into the local storage. Only SOP Instances, that are supported, can be retrieved from media storage.

See table → page B.2–1 for the Application Profiles listed that invoke this Application Entity for the Copy to Local Storage RWA.

Real-World Activity: Export to local Archive Media

The DICOM Archive application acts as FSU (for media with existing DICOM file-set) or FSC (media not initialized) using the interchange option when requested to copy SOP Instances from the local storage to local Archive medium.

The DICOM Archive application will receive a list of SOP Instances to be copied to the local archive medium. According to the state of the medium inserted (new medium, Medium with DICOM file-set) the SOP Instances are either updated or created on the media. Only valid SOP Instances are accepted.

The DICOM archive application will not close the CD-R medium.

**Application Profiles for the
RWA: Export to local
Archive Media**

See table → page B.2–1 for the Application Profiles listed that invoke this Application Entity for the Copy to local Archive RWA.

Note

If the image to be archived also has an Icon Image in the database then there will be a Icon Image SQ be generated in DICOMDIR file for this image. The Icon Image SQ will contain the following attributes:

- Samples Per Pixel (0028,0002) = 1
- Photometric Interpretation (0028,0004)
= "MONOCHROME2"
- Rows (0028,0010), Columns (0028,0011)
= 128,128 for XA IOD images
= 64,64 for other images
- Bits Allocated (0028,0100) = 8
- Bits Stored (0028,0101) = 8
- High Bit (0028,0102) = 7
- Pixel Representation (0028,0103) = 0 (unsigned int)
- Planar Configuration (0028, 0006) is not set
- Pixel Aspect Ration (0028,0034) is not set (aspect ratio is 1/1)

Application profiles

DICOMDIR keys

The DICOMDIR file will contain the following attributes for the levels Patient - Study - Series - Image/Curve (valid for all Application profiles described in this section):

Attribute Name	Tag	Type	Notes
File-Set identification			
File-set ID	(0004,1130)	2	volume label of media
Directory information			
Offset of the First Directory Record of the Root Directory Entry	(0004,1200)	1	
Offset of the Last Directory Record of the Root Directory Entity	(0004,1202)	1	
File-set Consistency Flag	(0004,1212)	1	0000H
Directory Record Sequence	(0004,1220)	2	
> Offset of the Next Directory Record	(0004,1400)	1C	
> Record In-use flag	(0004,1410)	1C	FFFFH
> Offset of Referenced Lower-Level Directory Entity	(0004,1420)	1C	
> Directory Record Type	(0004,1430)	1C	PATIENT, STUDY, SERIES, IMAGE, CURVE, PRIVATE (see → page B.3–9, <i>PRI-GEN-CD, PRI-CTMR-xxxx</i>)
> Referenced File ID	(0004,1500)	1C	contains the filename on media for the Directory Records of Type IMAGE and PRIVATE
> Referenced SOP Class UID in File	(0004,1510)	1C	for the Directory Records of Type IMAGE and PRIVATE

Attribute Name	Tag	Type	Notes
> Referenced SOP Instance UID in File	(0004,1511)	1C	for the Directory Records of Type IMAGE and PRIVATE
> Referenced Transfer Syntax UID in File	(0004,1512)	1C	for the Directory Records of Type IMAGE and PRIVATE
> Record Selection Keys	see below		
Patient Keys			Directory Record Type PATIENT
Specific Character Set	(0008,0005)	1C	see → Chapter B.6, <i>Support of Extended Character Sets</i>
Patient's Name	(0010,0010)	2	
Patient ID	(0010,0020)	1	
Date Of Birth	(0010,0030)	3	Type 2 in STD-XA-* profiles
Patient's Sex	(0010,0040)	3	Type 2 in STD-XA-* profiles
Study Keys			Directory Record Type STUDY
Specific Character Set	(0008,0005)	1C	see → Chapter B.6, <i>Support of Extended Character Sets</i>
Study Date	(0008,0020)	1	
Study Time	(0008,0030)	1	
Accession Number	(0008,0050)	2	
Study Description	(0008,1030)	2	
Study Instance UID	(0020,000D)	1C	
Study ID	(0020,0010)	1	Will be generated automatically, if not present. Value = "-"
Series Keys			Directory Record Type SERIES
Specific Character Set	(0008,0005)	1C	see → Chapter B.6, <i>Support of Extended Character Sets</i>
Series Date	(0008,0021)	3	
Series Time	(0008,0031)	3	

Attribute Name	Tag	Type	Notes
Modality	(0008,0060)	1	
Institution name	(0008,0080)	3	Type 2 in STD-XA* profiles
Institution Address	(0008,0081)	3	Type 2 in STD-XA* profiles
Series Description	(0008,103E)	3	
Performing Physician	(0008,1050)	3	Type 2 in STD-XA* profiles
Series Instance UID	(0020,000E)	1	
Series Number	(0020,0011)	1	
Image Keys			Directory Record Type IMAGE
Specific Character Set	(0008,0005)	1C	see → Chapter B.6, <i>Support of Extended Character Sets</i>
Image Type	(0008,0008)	3	identification characteristics Type 1 in STD-XA* profiles
SOP Class UID	(0008,0016)	3	
SOP Instance UID	(0008,0018)	3	
Image Date	(0008,0023)	3	
Image Time	(0008,0033)	3	
Referenced Image Sequence	(0008,1140)	3	Type 1C in STD-CTMR profile, required if present in image
> Referenced SOP Class UID	(0008,1150)		
> Referenced SOP Instance UID	(0008,1155)		
Image Number	(0020,0013)	1	
Image Position (Patient)	(0020,0032)	3	Type 1C in STD-CTMR profile, required if present in image
Image Orientation (Patient)	(0020,0037)	3	Type 1C in STD-CTMR profile, required if present in image
Frame Of Reference UID	(0020,0052)	3	Type 1C in STD-CTMR profile, required if present in image

Attribute Name	Tag	Type	Notes
Rows	(0028,0010)	3	
Columns	(0028,0011)	3	
Pixel Spacing	(0028,0030)	3	Type 1C in STD-CTMR profile, required if present in image
Calibration Image	(0050,0004)	3	Type 2 in STD-XA* profiles, for XA IOD
Icon Image Sequence	(0088,0200)	3	required for XA Application profiles, optional for the others
> Samples per Pixel	(0028,0002)		1
> Photometric Interpretation	(0028,0004)		MONOCHROME2
> Rows	(0028,0010)		128 for XA IOD, 64 otherwise Type 1 in STD-CTMR profile
> Columns	(0028,0011)		128 for XA IOD, 64 otherwise Type 1 in STD-CTMR profile
> Bits Allocated	(0028,0100)		8
> Bits Stored	(0028,0101)		8
> High Bit	(0028,0102)		7
> Pixel Representation	(0028,0103)		0 (unsigned)
> Pixel Data	(7FE0,0010)		Icon Image pixel data
Waveform Keys			Directory Record Type CURVE
Specific Character Set	(0008,0005)	1C	see → Chapter B.6, <i>Support of Extended Character Sets</i>
Curve Number	(0020,0024)	1	

see also → page B.3–9, *PRI-GEN-CD*, *PRI-CTMR-xxxx* for the DICOMDIR attributes set for CsaNonImage IOD.

STD-GEN-CD

For media conforming to the STD-GEN-CD Profile the following SOP classes will be supported as an FSR, FSC, FSU.

Information Object Definitions	SOP Class UID	Transfer Syntax and UID	FSC	FSR	FSU
CR Image	1.2.840.10008.5.1.4.1.1.1	Explicit VR Little Endian Uncompressed 1.2.840.10008.1.2.1	yes	yes	yes
CT Image	1.2.840.10008.5.1.4.1.1.2	Explicit VR Little Endian Uncompressed 1.2.840.10008.1.2.1	yes	yes	yes
US-MF image	1.2.840.10008.5.1.4.1.1.3.1	Explicit VR Little Endian Uncompressed 1.2.840.10008.1.2.1	yes	yes	yes
MR Image	1.2.840.10008.5.1.4.1.1.4	Explicit VR Little Endian Uncompressed 1.2.840.10008.1.2.1	yes	yes	yes
US Image	1.2.840.10008.5.1.4.1.1.6.1	Explicit VR Little Endian Uncompressed 1.2.840.10008.1.2.1	yes	yes	yes
SC Image	1.2.840.10008.5.1.4.1.1.7	Explicit VR Little Endian Uncompressed 1.2.840.10008.1.2.1	yes	yes	yes
12-lead ECG Waveform Storage	1.2.840.10008.5.1.4.1.1.9.1.1	Explicit VR Little Endian Uncompressed 1.2.840.10008.1.2.1	yes	yes	yes
General ECG Waveform Storage	1.2.840.10008.5.1.4.1.1.9.1.2	Explicit VR Little Endian Uncompressed 1.2.840.10008.1.2.1	yes	yes	yes
Ambulatory ECG Waveform Storage	1.2.840.10008.5.1.4.1.1.9.1.3	Explicit VR Little Endian Uncompressed 1.2.840.10008.1.2.1	yes	yes	yes
Hemodynamic Waveform Storage	1.2.840.10008.5.1.4.1.1.9.2.1	Explicit VR Little Endian Uncompressed 1.2.840.10008.1.2.1	yes	yes	yes

Information Object Definitions	SOP Class UID	Transfer Syntax and UID	FSC	FSR	FSU
Cardiac Electrophysiology Waveform Storage	1.2.840.10008.5.1.4.1.1.9.3.1	Explicit VR Little Endian Uncompressed 1.2.840.10008.1.2.1	yes	yes	yes
Basic Voice Audio Waveform Storage	1.2.840.10008.5.1.4.1.1.9.4.1	Explicit VR Little Endian Uncompressed 1.2.840.10008.1.2.1	yes	yes	yes
XA Image	1.2.840.10008.5.1.4.1.1.12.1	Explicit VR Little Endian Uncompressed 1.2.840.10008.1.2.1	yes	yes	yes
XA-BiPlane Image	1.2.840.10008.5.1.4.1.1.12.3	Explicit VR Little Endian Uncompressed 1.2.840.10008.1.2.1	yes	yes	yes
XRF-Image	1.2.840.10008.5.1.4.1.1.12.2	Explicit VR Little Endian Uncompressed 1.2.840.10008.1.2.1	yes	yes	yes
NM Image	1.2.840.10008.5.1.4.1.1.20	Explicit VR Little Endian Uncompressed 1.2.840.10008.1.2.1	yes	yes	yes
PET Image	1.2.840.10008.5.1.4.1.1.128	Explicit VR Little Endian Uncompressed 1.2.840.10008.1.2.1	yes	yes	yes
Digital X-Ray Image - For Processing	1.2.840.10008.5.1.4.1.1.1.1.1	Explicit VR Little Endian 1.2.840.10008.1.2.1	yes	yes	yes
Digital X-Ray Image - For Presentation	1.2.840.10008.5.1.4.1.1.1.1	Explicit VR Little Endian 1.2.840.10008.1.2.1	yes	yes	yes
Digital Mammography X-Ray Image - For Processing	1.2.840.10008.5.1.4.1.1.1.2.1	Explicit VR Little Endian 1.2.840.10008.1.2.1	yes	yes	yes

Information Object Definitions	SOP Class UID	Transfer Syntax and UID	FSC	FSR	FSU
Digital Mammography X-Ray Image - For Presentation	1.2.840.10008.5.1.4.1.1.1.2	Explicit VR Little Endian 1.2.840.10008.1.2.1	yes	yes	yes
RT Structure Set	1.2.840.10008.5.1.4.1.1.481.3	Explicit VR Little Endian 1.2.840.10008.1.2.1	yes	yes	yes

Standalone IODs (Standalone Overlay, Standalone Curve, ..) are not supported by either FSR/FSC/FSU.

Detached Patient Management is not supported for import and therefore no precedence of values from those Instances can be supported.

STD-CTMR-xxxx

For media conforming to the STD-CTMR-MOD650, STD-CTMR-MOD12, STD-CTMR-MOD23, STD-CTMR-CD Profiles the following SOP classes will be supported as an FSR, FSC,FSU.

Information Object Definitions	SOP Class UID	Transfer Syntax and UID	FSC	FSR	FSU
CT Image	1.2.840.10008.5.1.4.1.1.2	Explicit VR Little Endian Uncompressed 1.2.840.10008.1.2.1	yes	yes	yes
CT Image	1.2.840.10008.5.1.4.1.1.2	JPEG Lossless Process 14 (selection value 1) 1.2.840.10008.1.2.4.70	yes	yes	yes
MR Image	1.2.840.10008.5.1.4.1.1.4	Explicit VR Little Endian Uncompressed 1.2.840.10008.1.2.1	yes	yes	yes

Information Object Definitions	SOP Class UID	Transfer Syntax and UID	FSC	FSR	FSU
MR Image	1.2.840.10008.5.1.4.1.1.4	JPEG Lossless Process 14 (selection value 1) 1.2.840.10008.1.2.4.70	yes	yes	yes
SC Image (grayscale)	1.2.840.10008.5.1.4.1.1.7	Explicit VR Little Endian Uncompressed 1.2.840.10008.1.2.1	yes	yes	yes
SC Image (grayscale)	1.2.840.10008.5.1.4.1.1.7	JPEG Lossless Process 14 (selection value 1) 1.2.840.10008.1.2.4.70	yes	yes	yes
SC Image (palette color)	1.2.840.10008.5.1.4.1.1.7	Explicit VR Little Endian Uncompressed 1.2.840.10008.1.2.1	yes	yes	yes

Detached Patient Management is not supported for import and therefore no precedence of values from those Instances can be supported.

STD-XABC-CD

For media conforming to the STD-XABC-CD Profile the following SOP classes will be supported as an FSR, FSC,FSU.

Information Object Definitions	SOP Class UID	Transfer Syntax and UID	FSC	FSR	FSU
XA Image	1.2.840.10008.5.1.4.1.1.12.1	JPEG Lossless Process 14 (selection value 1) 1.2.840.10008.1.2.4.70	yes	yes	yes

Detached Patient Management is not supported for import and therefore no precedence of values from those Instances can be supported.

The FSC will create only images with Rows = Columns = 512 on the media.

STD-XA1K-CD

For media conforming to the STD-XABC-CD Profile the following SOP classes will be supported as an FSR, FSC, FSU.

Information Object Definitions	SOP Class UID	Transfer Syntax and UID	FSC	FSR	FSU
XA Image	1.2.840.10008.5.1.4.1.1.12.1	JPEG Lossless Process 14 (selection value 1) 1.2.840.10008.1.2.4.70	yes	yes	yes
SC Image	1.2.840.10008.5.1.4.1.1.7	Explicit VR Little Endian Uncompressed 1.2.840.10008.1.2.1	yes	yes	yes

Standalone IODs (Standalone Overlay, Standalone Curve, ..) are not supported by either FSR/FSC/FSU.

Detached Patient Management is not supported for import and therefore no precedence of values from those Instances can be supported.

STD-US-zz-yF-xxx (Single- and multiframe)

For media conforming to the STD-US-zz-yF-FLOP, STD-US-zz-yF-MOD128, STD-US-zz-yF-MOD230, STD-US-zz-yF-MOD540, STD-US-zz-yF-MOD650, STD-US-zz-yF-MOD12, STD-US-zz-yF-MOD23, STD-US-zz-yF-CDR Profiles the following SOP classes and transfer syntaxes will be supported as an FSR, FSC,FSU.

Note

- 'yF' in in the application profile name must be replaced by SF for Single Frame and MF for Multi Frame
- 'zz' in the application profile name must be replaced by any one of ID, SC, CC (Image Display, Spatial Calibration, Combined Calibration)

Information Object Definitions	SOP Class UID	Transfer Syntax and UID	FSC	FSR	FSU
Ultrasound Image	1.2.840.10008.5.1.4.1.1.6.1	Explicit VR Little Endian Uncompressed 1.2.840.10008.1.2.1	yes	yes	yes
Ultrasound Multiframe Image	1.2.840.10008.5.1.4.1.1.3.1	Explicit VR Little Endian Uncompressed 1.2.840.10008.1.2.1	yes	yes	yes

Only the following Photometric Interpretations are supported by FSR/FSC/FSU:

- MONOCHROME2
- PALETTE COLOR
- RGB

This restriction also applies for FSR.

STD-WVFM-GEN-FD

For media conforming to the STD-WVFM-GEN-FD Profile the following SOP classes will be supported as an FSR, FSC,FSU.

Information Object Definitions	SOP Class UID	Transfer Syntax and UID	FSC	FSR	FSU
12-lead ECG Waveform Storage	1.2.840.10008.5.1.4.1.1.9.1.1	Explicit VR Little Endian Uncompressed 1.2.840.10008.1.2.1	yes	yes	yes
General ECG Waveform Storage	1.2.840.10008.5.1.4.1.1.9.1.2	Explicit VR Little Endian Uncompressed 1.2.840.10008.1.2.1	yes	yes	yes
Ambulatory ECG Waveform Storage	1.2.840.10008.5.1.4.1.1.9.1.3	Explicit VR Little Endian Uncompressed 1.2.840.10008.1.2.1	yes	yes	yes
Hemodynamic Waveform Storage	1.2.840.10008.5.1.4.1.1.9.2.1	Explicit VR Little Endian Uncompressed 1.2.840.10008.1.2.1	yes	yes	yes
Cardiac Electrophysiology Waveform Storage	1.2.840.10008.5.1.4.1.1.9.3.1	Explicit VR Little Endian Uncompressed 1.2.840.10008.1.2.1	yes	yes	yes
Basic Voice Audio Waveform Storage	1.2.840.10008.5.1.4.1.1.9.4.1	Explicit VR Little Endian Uncompressed 1.2.840.10008.1.2.1	yes	yes	yes

Detached Patient Management is not supported for import and therefore no precedence of values from those Instances can be supported.



Augmented Application Profiles

When configuring a compressed Transfer Syntax the STD-CTMR and STD-GEN application profile classes will be extended to store instances of the following SOP classes in compressed format:

Augmented Application profiles, Activities, and Roles for DICOM Archive

Application Profiles Supported	Real World Activity	Role	SC Option
AUG-GEN-CD	Browse Directory Information	FSR	Interchange
AUG-CTMR-MOD650	Import into local Storage	FSR	Interchange
AUG-CTMR-MOD12			
AUG-CTMR-MOD23	Export to local archive media	FSC, FSU	Interchange
AUG-CTMR-CD			

AUG-GEN-CD, AUG-CTMR-xxxx

For media conforming to the AUG-GEN-CD or AUG-CTMR-MOD650, AUG-CTMR-MOD12, AUG-CTMR-MOD23, AUG-CTMR-CD Profile the following SOP classes will be supported as an FSR, FSC, FSU.

Information Object Definitions	SOP Class UID	Transfer Syntax and UID	FSC	FSR	FSU
CR Image	1.2.840.10008.5.1.4.1.1.1	Explicit VR Little Endian Uncompressed 1.2.840.10008.1.2.1	yes	yes	yes
CR Image	1.2.840.10008.5.1.4.1.1.1	Explicit VR Big Endian Uncompressed 1.2.840.10008.1.2.2	no	yes	no
CR Image	1.2.840.10008.5.1.4.1.1.1	JPEG Lossless Process 14 (selection value 1) 1.2.840.10008.1.2.4.70	yes	yes	yes
CR Image	1.2.840.10008.5.1.4.1.1.1	JPEG lossy (baseline or extended) 1.2.840.10008.1.2.4.50 1.2.840.10008.1.2.4.51	yes	yes	yes
CT Image	1.2.840.10008.5.1.4.1.1.2	Explicit VR Little Endian Uncompressed 1.2.840.10008.1.2.1	yes	yes	yes
CT Image	1.2.840.10008.5.1.4.1.1.2	Explicit VR Big Endian Uncompressed 1.2.840.10008.1.2.2	no	yes	no
CT Image	1.2.840.10008.5.1.4.1.1.2	JPEG Lossless Process 14 (selection value 1) 1.2.840.10008.1.2.4.70	yes	yes	yes
CT Image	1.2.840.10008.5.1.4.1.1.2	JPEG lossy (baseline or extended) 1.2.840.10008.1.2.4.50 1.2.840.10008.1.2.4.51	yes	yes	yes
US-MF image	1.2.840.10008.5.1.4.1.1.3.1	Explicit VR Little Endian Uncompressed 1.2.840.10008.1.2.1	yes	yes	yes

Information Object Definitions	SOP Class UID	Transfer Syntax and UID	FSC	FSR	FSU
US-MF image	1.2.840.10008.5.1.4.1.1.3.1	Explicit VR Big Endian Uncompressed 1.2.840.10008.1.2.2	no	yes	no
US-MF image	1.2.840.10008.5.1.4.1.1.3.1	JPEG Lossless Process 14 (selection value 1) 1.2.840.10008.1.2.4.70	yes	yes	yes
US-MF image	1.2.840.10008.5.1.4.1.1.3.1	JPEG lossy (baseline or extended) 1.2.840.10008.1.2.4.50 1.2.840.10008.1.2.4.51	yes	yes	yes
MR Image	1.2.840.10008.5.1.4.1.1.4	Explicit VR Little Endian Uncompressed 1.2.840.10008.1.2.1	yes	yes	yes
MR Image	1.2.840.10008.5.1.4.1.1.4	Explicit VR Big Endian Uncompressed 1.2.840.10008.1.2.2	no	yes	no
MR Image	1.2.840.10008.5.1.4.1.1.4	JPEG Lossless Process 14 (selection value 1) 1.2.840.10008.1.2.4.70	yes	yes	yes
MR Image	1.2.840.10008.5.1.4.1.1.4	JPEG lossy (baseline or extended) 1.2.840.10008.1.2.4.50 1.2.840.10008.1.2.4.51	yes	yes	yes
US Image	1.2.840.10008.5.1.4.1.1.6.1	Explicit VR Little Endian Uncompressed 1.2.840.10008.1.2.1	yes	yes	yes
US Image	1.2.840.10008.5.1.4.1.1.6.1	Explicit VR Big Endian Uncompressed 1.2.840.10008.1.2.2	no	yes	no
US Image	1.2.840.10008.5.1.4.1.1.6.1	JPEG Lossless Process 14 (selection value 1) 1.2.840.10008.1.2.4.70	yes	yes	yes
US Image	1.2.840.10008.5.1.4.1.1.6.1	JPEG lossy (baseline or extended) 1.2.840.10008.1.2.4.50 1.2.840.10008.1.2.4.51	yes	yes	yes

Information Object Definitions	SOP Class UID	Transfer Syntax and UID	FSC	FSR	FSU
SC Image	1.2.840.10008.5.1.4.1.1.7	Explicit VR Little Endian Uncompressed 1.2.840.10008.1.2.1	yes	yes	yes
SC Image	1.2.840.10008.5.1.4.1.1.7	Explicit VR Big Endian Uncompressed 1.2.840.10008.1.2.2	no	yes	no
SC Image	1.2.840.10008.5.1.4.1.1.7	JPEG Lossless Process 14 (selection value 1) 1.2.840.10008.1.2.4.70	yes	yes	yes
SC Image	1.2.840.10008.5.1.4.1.1.7	JPEG lossy (baseline or extended) 1.2.840.10008.1.2.4.50 1.2.840.10008.1.2.4.51	yes	yes	yes
12-lead ECG Waveform Storage	1.2.840.10008.5.1.4.1.1.9.1.1	Explicit VR Little Endian Uncompressed 1.2.840.10008.1.2.1	yes	yes	yes
General ECG Waveform Storage	1.2.840.10008.5.1.4.1.1.9.1.2	Explicit VR Little Endian Uncompressed 1.2.840.10008.1.2.1	yes	yes	yes
Ambulatory ECG Wave- form Storage	1.2.840.10008.5.1.4.1.1.9.1.3	Explicit VR Little Endian Uncompressed 1.2.840.10008.1.2.1	yes	yes	yes
Hemodynamic Waveform Storage	1.2.840.10008.5.1.4.1.1.9.2.1	Explicit VR Little Endian Uncompressed 1.2.840.10008.1.2.1	yes	yes	yes
Cardiac Elec- trophysiology Waveform Storage	1.2.840.10008.5.1.4.1.1.9.3.1	Explicit VR Little Endian Uncompressed 1.2.840.10008.1.2.1	yes	yes	yes
Basic Voice Audio Wave- form Storage	1.2.840.10008.5.1.4.1.1.9.4.1	Explicit VR Little Endian Uncompressed 1.2.840.10008.1.2.1	yes	yes	yes



Information Object Definitions	SOP Class UID	Transfer Syntax and UID	FSC	FSR	FSU
XA Image	1.2.840.10008.5.1.4.1.1.12.1	Explicit VR Little Endian Uncompressed 1.2.840.10008.1.2.1	yes	yes	yes
XA Image	1.2.840.10008.5.1.4.1.1.12.1	Explicit VR Big Endian Uncompressed 1.2.840.10008.1.2.2	no	yes	no
XA Image	1.2.840.10008.5.1.4.1.1.12.1	JPEG Lossless Process 14 (selection value 1) 1.2.840.10008.1.2.4.70	yes	yes	yes
XA Image	1.2.840.10008.5.1.4.1.1.12.1	JPEG lossy (baseline or extended) 1.2.840.10008.1.2.4.50 1.2.840.10008.1.2.4.51	yes	yes	yes
XA-BiPlane Image	1.2.840.10008.5.1.4.1.1.12.3	Explicit VR Little Endian Uncompressed 1.2.840.10008.1.2.1	yes	yes	yes
XA-BiPlane Image	1.2.840.10008.5.1.4.1.1.12.3	Explicit VR Big Endian Uncompressed 1.2.840.10008.1.2.2	no	yes	no
XA-BiPlane Image	1.2.840.10008.5.1.4.1.1.12.3	JPEG Lossless Process 14 (selection value 1) 1.2.840.10008.1.2.4.70	yes	yes	yes
XA-BiPlane Image	1.2.840.10008.5.1.4.1.1.12.3	JPEG lossy (baseline or extended) 1.2.840.10008.1.2.4.50 1.2.840.10008.1.2.4.51	yes	yes	yes
XRF-Image	1.2.840.10008.5.1.4.1.1.12.2	Explicit VR Little Endian Uncompressed 1.2.840.10008.1.2.1	yes	yes	yes
XRF-Image	1.2.840.10008.5.1.4.1.1.12.2	Explicit VR Big Endian Uncompressed 1.2.840.10008.1.2.2	no	yes	no
XRF-Image	1.2.840.10008.5.1.4.1.1.12.2	JPEG Lossless Process 14 (selection value 1) 1.2.840.10008.1.2.4.70	yes	yes	yes

Information Object Definitions	SOP Class UID	Transfer Syntax and UID	FSC	FSR	FSU
XRF-Image	1.2.840.10008.5.1.4.1.1.12.2	JPEG lossy (baseline or extended) 1.2.840.10008.1.2.4.50 1.2.840.10008.1.2.4.51	yes	yes	yes
NM Image	1.2.840.10008.5.1.4.1.1.20	Explicit VR Little Endian Uncompressed 1.2.840.10008.1.2.1	yes	yes	yes
NM Image	1.2.840.10008.5.1.4.1.1.20	Explicit VR Big Endian Uncompressed 1.2.840.10008.1.2.2	no	yes	no
NM Image	1.2.840.10008.5.1.4.1.1.20	JPEG Lossless Process 14 (selection value 1) 1.2.840.10008.1.2.4.70	yes	yes	yes
NM Image	1.2.840.10008.5.1.4.1.1.20	JPEG lossy (baseline or extended) 1.2.840.10008.1.2.4.50 1.2.840.10008.1.2.4.51	yes	yes	yes
PET Image	1.2.840.10008.5.1.4.1.1.128	Explicit VR Little Endian Uncompressed 1.2.840.10008.1.2.1	yes	yes	yes
PET Image	1.2.840.10008.5.1.4.1.1.128	Explicit VR Big Endian Uncompressed 1.2.840.10008.1.2.2	no	yes	no
PET Image	1.2.840.10008.5.1.4.1.1.128	JPEG Lossless Process 14 (selection value 1) 1.2.840.10008.1.2.4.70	yes	yes	yes
PET Image	1.2.840.10008.5.1.4.1.1.128	JPEG lossy (baseline or extended) 1.2.840.10008.1.2.4.50 1.2.840.10008.1.2.4.51	yes	yes	yes

Information Object Definitions	SOP Class UID	Transfer Syntax and UID	FSC	FSR	FSU
Digital X-Ray Image - For Processing	1.2.840.10008.5.1.4.1.1.1.1.1	Explicit VR Big Endian 1.2.840.10008.1.2.2 Explicit VR Little Endian 1.2.840.10008.1.2.1 JPEG Baseline 1.2.840.10008.1.2.4.50 JPEG Extended (2 & 4) 1.2.840.10008.1.2.4.51 JPEG Lossless Non-hierarchical 1.2.840.10008.1.2.4.70	yes	yes	yes
Digital X-Ray Image - For Presentation	1.2.840.10008.5.1.4.1.1.1.1	Explicit VR Big Endian 1.2.840.10008.1.2.2 Explicit VR Little Endian 1.2.840.10008.1.2.1 JPEG Baseline 1.2.840.10008.1.2.4.50 JPEG Extended (2 & 4) 1.2.840.10008.1.2.4.51 JPEG Lossless Non-hierarchical 1.2.840.10008.1.2.4.70	yes	yes	yes
Digital Mammography X-Ray Image - For Processing	1.2.840.10008.5.1.4.1.1.1.2.1	Explicit VR Big Endian 1.2.840.10008.1.2.2 Explicit VR Little Endian 1.2.840.10008.1.2.1 JPEG Baseline 1.2.840.10008.1.2.4.50 JPEG Extended (2 & 4) 1.2.840.10008.1.2.4.51 JPEG Lossless Non-hierarchical 1.2.840.10008.1.2.4.70	yes	yes	yes

Information Object Definitions	SOP Class UID	Transfer Syntax and UID	FSC	FSR	FSU
Digital Mammography X-Ray Image - For Presentation	1.2.840.10008.5.1.4.1.1.1.2	Explicit VR Big Endian 1.2.840.10008.1.2.2 Explicit VR Little Endian 1.2.840.10008.1.2.1 JPEG Baseline 1.2.840.10008.1.2.4.50 JPEG Extended (2 & 4) 1.2.840.10008.1.2.4.51 JPEG Lossless Non-hierarchical 1.2.840.10008.1.2.4.70	yes	yes	yes
RT Structure Set	1.2.840.10008.5.1.4.1.1.481.3	Explicit VR Big Endian 1.2.840.10008.1.2.2 Explicit VR Little Endian 1.2.840.10008.1.2.1	yes	yes	yes

Private Application Profiles

The following Private Application Profiles supported to store private objects in addition to the Standard SOP classes allowed for the corresponding Standard Application Profile.

Private Application profiles, Activities, and Roles for DICOM Archive

Application Profiles Supported	Real World Activity	Role	SC Option
PRI-GEN-CD	Browse Directory Information	FSR	Interchange
PRI-CTMR-MOD650	Import into local Storage	FSR	Interchange
PRI-CTMR-MOD12			
PRI-CTMR-MOD23	Export to local archive media	FSC, FSU	Interchange
PRI-CTMR-CD			

PRI-GEN-CD, PRI-CTMR-xxxx

For media conforming to the PRI-GEN-CD or PRI-CTMR-MOD650, PRI-CTMR-MOD12, PRI-CTMR-MOD23, PRI-CTMR-CD Profile the following SOP classes will be supported as an FSR, FSC, FSU in addition to the Standard SOP classes allowed for the corresponding Standard Application Profiles.

Information Object Definitions	SOP Class UID	Transfer Syntax and UID	FSC	FSR	FSU
CsaNonImage	1.3.12.2.1107.5.9.1	Explicit VR Little Endian Uncompressed 1.2.840.10008.1.2.1	yes	yes	yes

The DICOMDIR file will contain the Directory record as described in → page B.2–5, *Application profiles* but with the following Private Keys instead of the Image Keys:

Attribute Name	Tag	Private Creator	Type	Notes
Directory Record Type	(0004,1430)	-	1	PRIVATE
Private Record UID	(0004,1432)	-	1	1.3.12.2.1107.5.9.1
Private keys				
SOP Class UID	(0008,0016)	-	3	1.3.12.2.1107.5.9.1
SOP Instance UID	(0008,0018)	-	3	
Image Type	(0008,0008)	-	3	identification characteristics
Acquisition Date	(0008,0022)	-	3	The date the acquisition of data that resulted in this data set started.
Acquisition Time	(0008,0032)	-	3	The time the acquisition of data that resulted in this data set started.
Acquisition Number	(0020,0012)	-	3	A number identifying the single continuous gathering of data over a period of time which resulted in this data set.
CSA Data Type	(0029,xx08)	SIEMENS CSA NON-IMAGE	1	CSA Data identification characteristics.
CSA Data Version	(0029,xx09)	SIEMENS CSA NON-IMAGE	3	Version of CSA Non-Image Data

No Icon Image SQ will be stored for CsaNonImage objects.

*SOP Classes and Transfer
Syntaxes*

Not applicable.



AE Title Mapping

DICOM Media Storage AE Title

The DICOM Storage application (Image Manager) provides the application entity title:

CsalmageManager



The Somaris/5 DICOM archive application supports the ISO 8859 Latin 1 (ISO-IR 100) character set family and the same family with code extensions (ISO 2022 IR 100 Latin-1). For international versions the following character sets are supported:

- ❑ ISO_IR 13 Japanese (Katakana+Romaji) (JIS X 0201)
- ❑ ISO 2022 IR 13 Japanese (Katakana+Romaji)
- ❑ ISO 2022 IR 87 Kanji (JIS X 0208)
- ❑ ISO 2022 IR 159 Supplementary Kanji (JIS X 0212)

For the Chinese version the Chinese language character set GB2312 (ISO 2022 IR 58) is supported in a non-conforming way, combined with ISO 2022 IR 100 and ISO 2022 IR 87. If the produced media are required to be read by independent DICOM stations, the user interface must be configured in a language using the ISO 8859 Latin 1 character set.

When there is a mismatch between the SCS tags (0008,0005) and the characters in an IOD coming into the system, then the following measures are taken to make the characters DICOM conform: Try to import with ISO-IR 100. If ISO-IR 100 also fails convert each illegal character to'?'.

