

e.soft 3.5 syngo®

SW

DICOM Conformance Statement

Table of Contents

Document and Release History	6
Document History	6
1 Introduction.....	7
1.1 Overview.....	7
1.2 Audience	7
1.3 Remarks.....	7
1.4 Definitions, Terms and Abbreviations.....	8
1.5 References.....	8
1.6 Structure	8
2 Implementation Model Verification	9
2.1 Application Data Flow Diagram.....	9
Figure 1: Application Data Flow Diagram - Verification SCU	9
2.2 Functional Definitions of Applications.....	9
2.3 Sequencing of Real-World Activities.....	9
3 Application Entity Specification Verification	10
3.1 Verification AE Specification.....	10
3.1.1 Association Establishment Policies	10
3.1.2 Association Initiation Policy.....	10
3.1.3 Association Acceptance Policy.....	11
4 Implementation Model Storage.....	12
4.1 Application Data Flow Diagram.....	12
Figure 2: Application Data Flow Diagram – Storage SCU/SCP.....	12
4.2 Functional Definitions of Application Entities	12
4.3 Sequencing of Real-World Activities.....	12
5 Application Entity Specification Storage	13
5.1 Storage AEs Specification	13
5.1.1 Association Establishment Policies	15
5.1.2 Association Initiation Policy.....	16
5.1.3 Association Acceptance Policy.....	20
6 Implementation Model Storage Commitment.....	28
6.1 Application Data Flow Diagram.....	28
Figure 3: Application Data Flow Diagram – Storage Commitment SCU/SCP.....	28
6.2 Functional Definitions of Application Entities	28
6.3 Sequencing of real World Activities.....	29

7	<i>AE Specification Storage Commitment</i>	30
7.1	Storage Commitment AE Specification	30
7.1.1	Association Establishment Policies	30
7.1.2	Association Initiation Policy.....	30
7.1.3	Association Acceptance Policy.....	32
8	<i>Implementation Model Query / Retrieve</i>	35
8.1	Application Data Flow Diagram.....	35
	<i>Figure 4: e.soft Application Data Flow Diagram – Query/Retrieve SCU</i>	35
	<i>Figure 5: e.soft Application Data Flow Diagram – Query/Retrieve SCP</i>	35
8.2	Functional Definitions of Application Entities	36
8.3	Sequencing of Real-World Activities.....	36
9	<i>Application Entity Specification Query/Retrieve</i>	37
9.1	Query/Retrieve Service AEs Specification	37
9.1.1	Association Establishment Policies	38
9.1.2	Association Initiation Policy.....	38
9.1.3	Association Acceptance Policy.....	43
10	<i>Implementation Model Print</i>	51
10.1	Application Data Flow Diagram.....	51
	<i>Figure 6: DICOM Application Data Flow Diagram– Print SCU</i>	51
10.2	Functional Definition of Application Entities.....	51
10.3	Sequencing of Real-World Activities.....	51
11	<i>Application Entity Specification Print</i>	52
11.1	Print Management AE Specification	52
11.1.1	Association Establishment Policies	52
11.1.2	Association Initiation Policy.....	53
11.1.3	Association Acceptance Policy.....	59
12	<i>Implementation Model Worklist</i>	60
12.1	Application Data Flow Diagram.....	60
	<i>Figure 7: e.soft Application Flow Diagram – Basic Worklist SCU</i>	60
12.2	Functional Definitions of Application Entities.....	60
12.3	Sequencing of Real-World Activities.....	61
13	<i>Application Entity Specification Worklist</i>	62
13.1	Modality Worklist Service AE Specification.....	62
13.1.1	Association Establishment Policies	62
13.1.2	Association Initiation Policy.....	63
14	<i>Implementation Model MPPS</i>	69
14.1	Application Data Flow Diagram.....	69
	<i>Figure 8: e.soft Application Flow Diagram – MPPS SCU</i>	69
14.2	Functional Definitions of Application Entities.....	69
15	<i>AE Specification MPPS</i>	70

15.1	Modality Performed Procedure Step AE Specification.....	70
15.1.2	Association Initiation Policy.....	70
16	Communication Profiles	75
16.1	Supported Communication Stacks.....	75
16.1.1	TCP/IP Stack.....	75
17	Extensions / Specializations / Privatizations	76
17.1.1	Standard Extended / Specialized / Private SOPs	76
17.1.2	Private Transfer Syntaxes	76
18	Configuration.....	76
18.1	AE Title/Presentation Address Mapping	76
18.1.1	DICOM Verification	76
18.1.2	DICOM Storage AE Title.....	76
18.1.3	DICOM Query/Retrieve AE Title	77
18.1.4	DICOM Print AE Title	77
18.2	Configurable Parameters	77
18.2.1	Storage, Storage Commitment and Query/Retrieve	77
18.2.2	Print	77
18.2.3	Modality Worklist.....	78
18.3	Default Parameters.....	78
19	Support of Extended Character Sets	79
Media Storage Conformance Statement.....		80
1	Introduction.....	81
1.1	Purpose	81
1.2	Scope.....	81
1.3	Definitions, Abbreviations	81
1.3.1	Definitions	81
1.3.2	Abbreviations	81
1.4	References.....	81
1.5	Remarks.....	82
2	Implementation Model.....	83
2.1	Application Data Flow Diagram.....	83
2.2	Functional Definitions of AEs	83
2.3	Sequencing of Real-World Activities.....	83
2.4	File Meta Information Options.....	84
3	AE Specifications	84
3.1	DICOM Archive Specification	84
3.1.1	File Meta Information for the Application Entity	84
3.1.2	Real-World Activities for this Application Entity	84
4	Augmented and Private Profiles	87
4.1	Augmented Application Profiles.....	87
4.1.1	AUG-GEN-CD.....	87
4.1.2	AUG-XA1K-CD.....	87
4.2	syngo® private offline Media Application Profile.....	87

- 4.2.1 Class and Profile Identification.....87
- 4.2.2 Clinical Context88
- 4.2.3 PRI-SYNGO Profiles89
- 5 Extensions, Specialization and Privatization of SOP Classes and Transfer Syntaxes 94**
- 5.1 SOP Specific Conformance Statement for Basic Directory..... 94
 - 5.1.1 Extension, Specialization for SIEMENS Non-Image Objects94
- 6 Configuration..... 94**
- 6.1 AE Title Mapping 94
 - 6.1.1 DICOM Media Storage AE Title.....94
- 7 Support of Extended Character Sets 94**

Document and Release History

Document History

Version	Date of Issue	Change & Reason of Change/Change Request/CHARM
R 1.0	April 2000	e.soft 1.0
R 2.0	April 2002	e.soft 2.0
R 3.0	June, 2002	e.soft 2.1
R 4.0	April, 2003	e.soft 2.5
R 5.0	October, 2003	e.soft 3.0
R 6.0	January, 2004	e.soft 3.5

© Siemens AG 2003
All rights reserved

syngo is a registered trademark of Siemens AG.

1 Introduction

1.1 Overview

The Conformance Statement describes the DICOM interface for e.soft 3.5 products in terms of part 2 of [DICOM].

This introduction describes the application's implemented DICOM functionality in general terms.

The e.soft is a “*syngo*[®]-speaking^{a)}” NM Imaging Modality workstation. The e.soft product is designed to be integrated into an environment of medical DICOM-based devices. The e.soft DICOM network implementation acts as SCU and SCP for the DICOM Storage, Storage Commitment and Query/Retrieve services and as SCU for the DICOM Print, DICOM Basic Worklist and Modality Performed Procedure Step Services. Verification is supported in SCU (only via Service environment) and SCP role. Furthermore the handling of [CD/MOD] offline media is supported as a FSC, FSU and FSR.

1.2 Audience

This document is intended for hospital staff, health system integrators, software designers or implementers. It is assumed that the reader has a working understanding of DICOM.

1.3 Remarks

DICOM, by itself, does not guarantee interoperability. However, the Conformance Statement facilitates a first-level validation for interoperability between different applications supporting the same DICOM functionality as SCU and SCP, respectively.

This Conformance Statement is not intended to replace validation with other DICOM equipment to ensure proper exchange of information intended.

The scope of this Conformance Statement is to facilitate communication with e.soft and other vendors' Medical equipment. The Conformance Statement should be read and understood in conjunction with the DICOM 3.0 Standard [DICOM]. However, by itself it is not guaranteed to ensure the desired interoperability and a successful interconnectivity.

The user should be aware of the following important issues:

- The comparison of different conformance statements is the first step towards assessing interconnectivity between e.soft and non-e.soft equipment.
- Test procedures should be defined and tests should be performed by the user to validate the connectivity desired. DICOM itself and the conformance parts do not specify this.
- The standard will evolve to meet the users' future requirements. Siemens is actively involved in developing the standard further and therefore reserves the right to make changes to its products or to discontinue its delivery.
- *syngo* reserves the right to modify the design and specifications contained herein without prior notice. Please contact your local sales representative for the most recent product information.

^{a)} *syngo* is a registered trademark of Siemens AG

1.4 Definitions, Terms and Abbreviations

Definitions, terms and abbreviations used in this document are defined within the different parts of the DICOM standard.

Additional Abbreviations and terms are as follows:

ACR	American College of Radiology
AE	DICOM Application Entity
ASCII	American Standard Code for Information Interchange
CSE	Customer Service Engineer
DB	Database
DCS	DICOM Conformance Statement
DSA	Digital Subtraction Angiography
IIDC	Image-Intensifier Distortion Correction
IOD	DICOM Information Object Definition
ISO	International Standard Organization
e.soft	Multimodality-Workstation
NEMA	National Electrical Manufacturers Association
•	Optional Key Attribute
PDU	DICOM Protocol Data Unit
R	Required Key Attribute
RIS	Radiology Information System
RWA	Real-World Activity
SCU	DICOM Service Class User (DICOM client)
SCP	DICOM Service Class Provider (DICOM server)
SOP	DICOM Service-Object Pair
U	Unique Key Attribute

1.5 References

[DICOM] Digital Imaging and Communications in Medicine (DICOM), NEMA PS 3.1-3.15, 2001

1.6 Structure

This Conformance Statement is subdivided into multiple Parts, which relate to individual documents needed to declare Conformance according to the requirements of "Part 2 - Conformance" of the DICOM Standard.

Those parts are:

- - "Network Conformance Statement" for Network related Services
 - • Storage - User/Provider (includes Verification - User/Provider)
 - • Storage Commitment - User/Provider
 - • Query/Retrieve - User/Provider
 - • Basic Grayscale/Color Print - User
 - • Basic Worklist - User
 - • Modality Performed Procedure Step - User
- - A privately defined "Media Conformance Statement"
- - and the "Offline Media Conformance Statement" to support local archive media.
- - A general Appendix.

2 Implementation Model Verification

The e.soft DICOM Service Tool application requests Verification to verify the ability of a foreign DICOM application on a remote node to respond to DICOM messages.

Responding to Verification requests from remote nodes is handled by the Storage SCP application.

2.1 Application Data Flow Diagram

The e.soft DICOM network implementation acts as SCU for the C-ECHO DICOM network service. The product target Operating System is Microsoft Windows XP Professional.

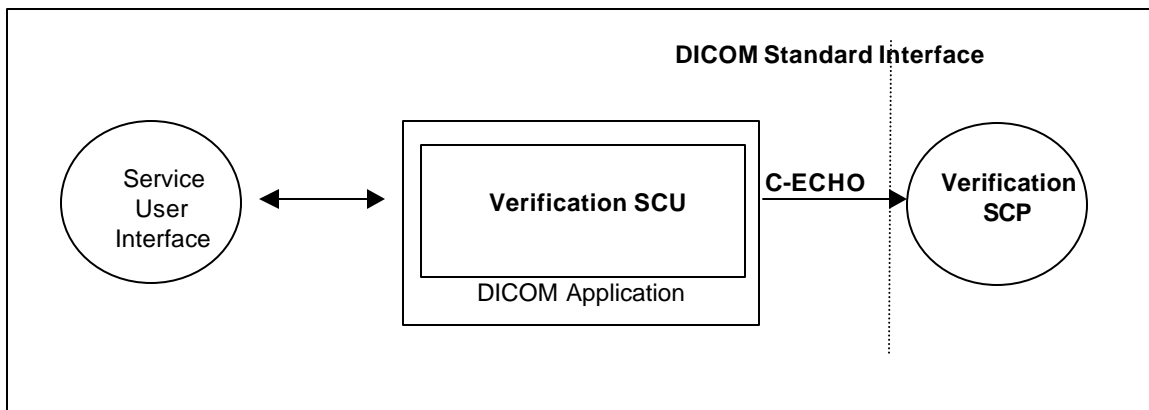

Figure 1: Application Data Flow Diagram - Verification SCU

2.2 Functional Definitions of Applications

The e.soft DICOM Service Tool application opens an association when a "verification" of a remote application is requested during a configuration session. This can be done when entering new data for remote application configuration or to verify existing configuration data.

2.3 Sequencing of Real-World Activities

Newly entered data have to be saved first, before a "verification" of these data is possible.

3 Application Entity Specification Verification

3.1 Verification AE Specification

3.1.1 Association Establishment Policies

3.1.1.1 General

The e.soft DICOM Service Tool application attempts to open an association for verification request whenever the “verification” function is activated during network configuration of a remote DICOM application.

3.1.1.2 Number of Associations

The e.soft DICOM Service Tool application initiates one association at a time to request verification.

3.1.1.3 Asynchronous Nature

The e.soft DICOM software does not support asynchronous communication (multiple outstanding transactions over a single association).

3.1.1.4 Implementation Identifying Information

Implementation Class UID	1.3.12.2.1107.5.9.20010101
Implementation Version Name	SIEMENS_SWFVD20K

3.1.2 Association Initiation Policy

The e.soft DICOM Service Tool application attempts to initiate a new association for

- DIMSE C-ECHO service operations.

3.1.2.1 Associated Real-World Activity - Verification

3.1.2.1.1 Associated Real-World Activity – Request Verification “verification”

The associated Real-World activity is a C-ECHO request initiated by Service and Configuration SW environment whenever a “verification” is requested. If an association to a remote Application Entity is successfully established, Verification with the configured AET is requested via the open association. If the C-ECHO Response from the remote Application contains a status other than “Success” this will be indicated in the service environment and the association is closed.

3.1.2.1.2 Proposed Presentation Contexts

The e.soft DICOM application will propose Presentation Contexts as shown in the following table:

Presentation Context Table – Verification SCU

Abstract Syntax		Transfer Syntax		Role	Extended Negotiation
Name	UID	Name List	UID List		
Verification	1.2.840.10008.1.1	Implicit VR Little Endian Explicit VR Big Endian Explicit VR Little Endian	1.2.840.10008.1.2 1.2.840.10008.1.2.2 1.2.840.10008.1.2.1	SCU	None

3.1.2.1.3 SOP Specific Conformance – Verification SCU

The Application conforms to the definitions of the Verification SCU in accordance to the DICOM Standard.

3.1.3 Association Acceptance Policy

The Verification SCP is part of the Storage SCP – see section 5.1.3 .

4 Implementation Model Storage

The e.soft DICOM Application Entity both originates associations for Storage of DICOM Composite Information Objects in Remote Application Entities and accepts association requests for Storage from Remote Application Entities.

4.1 Application Data Flow Diagram

The e.soft DICOM network implementation acts as SCU and SCP for the C-STORE DICOM network service and as SCP for the C-ECHO DICOM network service. The product target Operating System is Microsoft Windows XP Professional

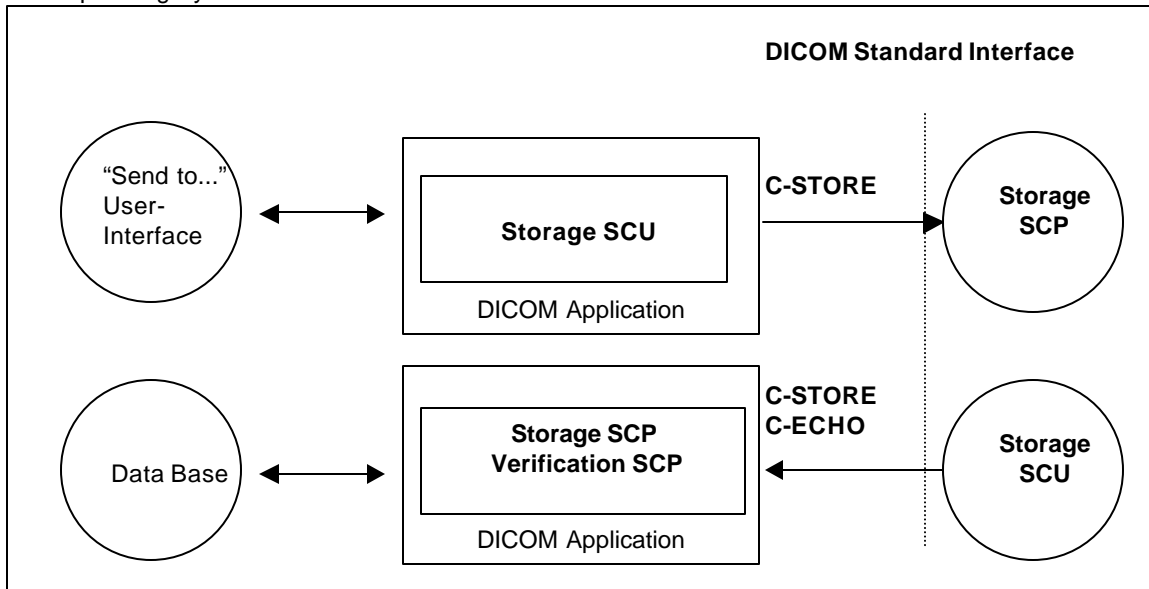

Figure 2: Application Data Flow Diagram – Storage SCU/SCP

4.2 Functional Definitions of Application Entities

The Storage SCU is invoked by the job control interface that is responsible for processing network archival tasks. The job consists of data describing the composite image objects selected for storage and the destination. An association is negotiated with the destination application entity and the image data is transferred using the C-STORE DIMSE-Service. Status of the transfer is reported to the job control interface.

The Storage SCP component of the e.soft DICOM application is operating as background server process. It is existing when the machine is powered on and waits for Storage association requests. Upon accepting an association with a negotiated Presentation Context it starts to receive the Composite Image Objects and imports them to local database. Verification requests will be processed and responded by Storage SCP component too.

4.3 Sequencing of Real-World Activities

not applicable

5 Application Entity Specification Storage

5.1 Storage AEs Specification

The e.soft Storage service class user/service class provider applications use one AE when initiating/receiving associations to/from remote DICOM nodes.

e.soft provides Standard Conformance to the following DICOM V3.0 SOP Classes as an SCU:

SOP Class Name	SOP Class UID
Computed R adiography Image Storage	1.2.840.10008.5.1.4.1.1.1
Computed T omography Image Storage	1.2.840.10008.5.1.4.1.1.2
Digital X -Ray Image Storage – for Processing	1.2.840.10008.5.1.4.1.1.1.1.1
Digital X -Ray Image Storage – for Presentation	1.2.840.10008.5.1.4.1.1.1.1
Digital M ammo G raphy Image Storage – for Processing	1.2.840.10008.5.1.4.1.1.1.2.1
Digital M ammo G raphy Image Storage – for Presentation	1.2.840.10008.5.1.4.1.1.1.2
Digital I ntra- o ral X -Ray Image Storage – for Presentation	1.2.840.10008.5.1.4.1.1.1.3.1
Digital I ntra- o ral X -Ray Image Storage – for Presentation	1.2.840.10008.5.1.4.1.1.1.3
M agnetic R esonance Image Storage	1.2.840.10008.5.1.4.1.1.4
N uclear M edicine Image Storage	1.2.840.10008.5.1.4.1.1.20
P ET Image Storage	1.2.840.10008.5.1.4.1.1.128
R adio T herapy S tructure S et Storage	1.2.840.10008.5.1.4.1.1.481.3
R adio T herapy D ose Storage	1.2.840.10008.5.1.4.1.1.481.2
R adio T herapy I mage Storage	1.2.840.10008.5.1.4.1.1.481.1
R adio T herapy P lan Storage	1.2.840.10008.5.1.4.1.1.481.5
S econdary C apture Image Storage	1.2.840.10008.5.1.4.1.1.7
U ltra S ound Multi -Frame Image Storage	1.2.840.10008.5.1.4.1.1.3.1
U ltra S ound Image Storage	1.2.840.10008.5.1.4.1.1.6.1
X -Ray A ngiographic Image Storage	1.2.840.10008.5.1.4.1.1.12.1
X -Ray R adio F luoroscopic Image Storage	1.2.840.10008.5.1.4.1.1.12.2
12 -lead E CG Waveform Storage	1.2.840.10008.5.1.4.1.1.9.1.1
A mbulatory E CG Waveform Storage	1.2.840.10008.5.1.4.1.1.9.1.3
B asic V oice A udio Waveform Storage	1.2.840.10008.5.1.4.1.1.9.4.1
C ardiac E lectrophysiology Waveform Storage	1.2.840.10008.5.1.4.1.1.9.3.1

General ECG Waveform Storage	1.2.840.10008.5.1.4.1.1.9.1.2
Hemodynamic Waveform Storage	1.2.840.10008.5.1.4.1.1.9.2.1

e.soft provides Private Conformance to the following DICOM V3.0 conform private SOP Classes as an SCU:

SOP Class Name	SOP Class UID
CSA Non-Image Storage	1.3.12.2.1107.5.9.1

e.soft provides Standard Conformance to the following DICOM V3.0 SOP Classes as an SCP:

SOP Class Name	SOP Class UID
Computed R adiography Image Storage	1.2.840.10008.5.1.4.1.1.1
Computed T omography Image Storage	1.2.840.10008.5.1.4.1.1.2
Digital X -Ray Image Storage – for Processing	1.2.840.10008.5.1.4.1.1.1.1
Digital X -Ray Image Storage – for Presentation	1.2.840.10008.5.1.4.1.1.1.1
Digital M ammo G raphy Image Storage – for Processing	1.2.840.10008.5.1.4.1.1.1.2.1
Digital M ammo G raphy Image Storage – for Presentation	1.2.840.10008.5.1.4.1.1.1.2
Digital I ntra-oral X -Ray Image Storage – for Presentation	1.2.840.10008.5.1.4.1.1.1.3.1
Digital I ntra-oral X -Ray Image Storage – for Presentation	1.2.840.10008.5.1.4.1.1.1.3
M agnetic R esonance Image Storage	1.2.840.10008.5.1.4.1.1.4
N uclear M edicine Image Storage	1.2.840.10008.5.1.4.1.1.20
P ET Image Storage	1.2.840.10008.5.1.4.1.1.128
R adio T herapy S tructure S et Storage	1.2.840.10008.5.1.4.1.1.481.3
R adio T herapy D ose Storage	1.2.840.10008.5.1.4.1.1.481.2
R adio T herapy I mage Storage	1.2.840.10008.5.1.4.1.1.481.1
R adio T herapy P lan Storage	1.2.840.10008.5.1.4.1.1.481.5
S econdary C apture Image Storage	1.2.840.10008.5.1.4.1.1.7
U ltra S ound Multi -Frame Image Storage (retired)	1.2.840.10008.5.1.4.1.1.3
U ltra S ound Multi -Frame Image Storage	1.2.840.10008.5.1.4.1.1.3.1
U ltra S ound Image Storage	1.2.840.10008.5.1.4.1.1.6.1
U ltra S ound Image Storage (retired)	1.2.840.10008.5.1.4.1.1.6
X -Ray A ngiographic Image Storage	1.2.840.10008.5.1.4.1.1.12.1

SOP Class Name	SOP Class UID
X-Ray RadioFluoroscopic Image Storage	1.2.840.10008.5.1.4.1.1.12.2
12-lead ECG Waveform Storage	1.2.840.10008.5.1.4.1.1.9.1.1
Ambulatory ECG Waveform Storage	1.2.840.10008.5.1.4.1.1.9.1.3
Basic Voice Audio Waveform Storage	1.2.840.10008.5.1.4.1.1.9.4.1
Cardiac Electrophysiology Waveform Storage	1.2.840.10008.5.1.4.1.1.9.3.1
General ECG Waveform Storage	1.2.840.10008.5.1.4.1.1.9.1.2
Hemodynamic Waveform Storage	1.2.840.10008.5.1.4.1.1.9.2.1
Verification	1.2.840.10008.1.1

e.soft provides Private Conformance to the following DICOM V3.0 conform private SOP Classes as an SCP:

SOP Class Name	SOP Class UID
CSA Non-Image Storage	1.3.12.2.1107.5.9.1

5.1.1 Association Establishment Policies

5.1.1.1 General

The existence of a job queue entry with network destination or an internal trigger from processing a retrieve request will activate the DICOM Storage Application. An association request is sent to the destination AE and upon successful negotiation of a Presentation Context the transfer is started. The default PDU size used will be 256 KB.

5.1.1.2 Number of Associations

The e.soft DICOM application initiates several associations at a time, one for each destination to which a transfer request is being processed in the active job queue list.

The e.soft DICOM application is able to accept multiple associations at a time. It can handle up to 10 associations in parallel.

The number of Simultaneous DICOM associations can be configured via the Service-UI. The dialog can be found in Configuration / DICOM / General.

5.1.1.3 Asynchronous Nature

The e.soft DICOM software does not support asynchronous communication (multiple outstanding transactions over a single association).

5.1.1.4 Implementation Identifying Information

Implementation Class UID	1.3.12.2.1107.5.9.20000101
Implementation Version Name	SIEMENS_SWFVD20K

5.1.2 Association Initiation Policy

If a job with network destination gets active in the job list or a retrieve sub-operation is processed the e.soft DICOM application attempts to initiate a new association for

- DIMSE C-STORE service operations.

5.1.2.1 Associated Real-World Activity - Send

5.1.2.1.1 Associated Real-World Activity – Send Image Objects to a Network Destination

The associated Real-World activity is a C-STORE request initiated by an internal daemon process triggered by a job with network destination or the processing of an external C-MOVE retrieve request. If the process successfully establishes an association to a remote Application Entity, it will transfer each image one after another via the open association. If the C-STORE Response from the remote Application contains a status other than “Success” or “Warning”, the association is aborted.

5.1.2.1.2 Proposed Presentation Context – Send Images

The e.soft DICOM application will propose Presentation Contexts as shown in the following table:

Presentation Context Table					
Abstract Syntax		Transfer Syntax		Role	Ext. Neg.
Name	UID	Name List	UID List		
Computed Radiography Image	1.2.840.10008.5.1.4.1.1.1	JPEG Lossy Extended *1 (Process 2 & 4)	1.2.840.10008.1.2.4.51	SCU	None
		JPEG Lossless, Process 14 (selection value 1)	1.2.840.10008.1.2.4.70		
		JPEG Lossy Baseline (Process 1) *1	1.2.840.10008.1.2.4.50		
		Explicit VR Little Endian	1.2.840.10008.1.2.1		
		Explicit VR Big Endian	1.2.840.10008.1.2.2		
		Implicit VR Little Endian	1.2.840.10008.1.2		
Computed Tomography Image	1.2.840.10008.5.1.4.1.1.2	JPEG Lossy Extended *1 (Process 2 & 4)	1.2.840.10008.1.2.4.51	SCU	None
		JPEG Lossless, Process 14 (selection value 1)	1.2.840.10008.1.2.4.70		
		JPEG Lossy Baseline (Process 1) *1	1.2.840.10008.1.2.4.50		
		Explicit VR Little Endian	1.2.840.10008.1.2.1		
		Explicit VR Big Endian	1.2.840.10008.1.2.2		
		Implicit VR Little Endian	1.2.840.10008.1.2		

Presentation Context Table					
Abstract Syntax		Transfer Syntax		Role	Ext. Neg.
Name	UID	Name List	UID List		
Digital X-Ray Image for processing	1.2.840.10008.5.1.4.1.1.1.1.1	JPEG Lossy Extended *1 (Process 2 & 4) JPEG Lossless, Process 14 (selection value 1) JPEG Lossy Baseline (Process 1) *1 Explicit VR Little Endian Explicit VR Big Endian Implicit VR Little Endian	1.2.840.10008.1.2.4.51 1.2.840.10008.1.2.4.70 1.2.840.10008.1.2.4.50 1.2.840.10008.1.2.1 1.2.840.10008.1.2.2 1.2.840.10008.1.2	SCU	None
Digital X-Ray Image for presentation	1.2.840.10008.5.1.4.1.1.1.1.1	JPEG Lossy Extended *1 (Process 2 & 4) JPEG Lossless, Process 14 (selection value 1) JPEG Lossy Baseline (Process 1) *1 Explicit VR Little Endian Explicit VR Big Endian Implicit VR Little Endian	1.2.840.10008.1.2.4.51 1.2.840.10008.1.2.4.70 1.2.840.10008.1.2.4.50 1.2.840.10008.1.2.1 1.2.840.10008.1.2.2 1.2.840.10008.1.2	SCU	None
MammoGraphy Image for processing	1.2.840.10008.5.1.4.1.1.1.2.1	JPEG Lossy Extended *1 (Process 2 & 4) JPEG Lossless, Process 14 (selection value 1) JPEG Lossy Baseline (Process 1) *1 Explicit VR Little Endian Explicit VR Big Endian Implicit VR Little Endian	1.2.840.10008.1.2.4.51 1.2.840.10008.1.2.4.70 1.2.840.10008.1.2.4.50 1.2.840.10008.1.2.1 1.2.840.10008.1.2.2 1.2.840.10008.1.2	SCU	None
MammoGraphy Image for presentation	1.2.840.10008.5.1.4.1.1.1.2.2	JPEG Lossy Extended *1 (Process 2 & 4) JPEG Lossless, Process 14 (selection value 1) JPEG Lossy Baseline (Process 1) *1 Explicit VR Little Endian Explicit VR Big Endian Implicit VR Little Endian	1.2.840.10008.1.2.4.51 1.2.840.10008.1.2.4.70 1.2.840.10008.1.2.4.50 1.2.840.10008.1.2.1 1.2.840.10008.1.2.2 1.2.840.10008.1.2	SCU	None
Digital Intra-oral X-Ray Image for processing	1.2.840.10008.5.1.4.1.1.1.3.1	JPEG Lossy Extended *1 (Process 2 & 4) JPEG Lossless, Process 14 (selection value 1) JPEG Lossy Baseline (Process 1) *1 Explicit VR Little Endian Explicit VR Big Endian Implicit VR Little Endian	1.2.840.10008.1.2.4.51 1.2.840.10008.1.2.4.70 1.2.840.10008.1.2.4.50 1.2.840.10008.1.2.1 1.2.840.10008.1.2.2 1.2.840.10008.1.2	SCU	None
Digital Intra-oral X-Ray Image for presentation	1.2.840.10008.5.1.4.1.1.1.3.2	JPEG Lossy Extended *1 (Process 2 & 4) JPEG Lossless, Process 14 (selection value 1) JPEG Lossy Baseline (Process 1) *1 Explicit VR Little Endian Explicit VR Big Endian Implicit VR Little Endian	1.2.840.10008.1.2.4.51 1.2.840.10008.1.2.4.70 1.2.840.10008.1.2.4.50 1.2.840.10008.1.2.1 1.2.840.10008.1.2.2 1.2.840.10008.1.2	SCU	None
Magnetic Resonance Image	1.2.840.10008.5.1.4.1.1.4	JPEG Lossy Extended *1 (Process 2 & 4) JPEG Lossless, Process 14 (selection value 1) JPEG Lossy Baseline (Process 1) *1 Explicit VR Little Endian Explicit VR Big Endian Implicit VR Little Endian	1.2.840.10008.1.2.4.51 1.2.840.10008.1.2.4.70 1.2.840.10008.1.2.4.50 1.2.840.10008.1.2.1 1.2.840.10008.1.2.2 1.2.840.10008.1.2	SCU	None
Nuclear Medicine Image	1.2.840.10008.5.1.4.1.1.20	Explicit VR Little Endian Explicit VR Big Endian Implicit VR Little Endian	1.2.840.10008.1.2.1 1.2.840.10008.1.2.2 1.2.840.10008.1.2	SCU	None

Presentation Context Table					
Abstract Syntax		Transfer Syntax		Role	Ext. Neg.
Name	UID	Name List	UID List		
PET Image	1.2.840.10008.5.1.4.1.1.128	Explicit VR Little Endian Explicit VR Big Endian Implicit VR Little Endian	1.2.840.10008.1.2.1 1.2.840.10008.1.2.2 1.2.840.10008.1.2	SCU	None
RT Structure Set	1.2.840.10008.5.1.4.1.1.481.3	Explicit VR Little Endian Explicit VR Big Endian Implicit VR Little Endian	1.2.840.10008.1.2.1 1.2.840.10008.1.2.2 1.2.840.10008.1.2	SCU	None
RT Dose	1.2.840.10008.5.1.4.1.1.481.2	JPEG Lossy Extended *1 (Process 2 & 4) JPEG Lossless, Process 14 (selection value 1) JPEG Lossy Baseline (Process 1) *1 Explicit VR Little Endian Explicit VR Big Endian Implicit VR Little Endian	1.2.840.10008.1.2.4.51 1.2.840.10008.1.2.4.70 1.2.840.10008.1.2.4.50 1.2.840.10008.1.2.1 1.2.840.10008.1.2.2 1.2.840.10008.1.2	SCU	None
RT Image	1.2.840.10008.5.1.4.1.1.481.1	JPEG Lossy Extended *1 (Process 2 & 4) JPEG Lossless, Process 14 (selection value 1) JPEG Lossy Baseline (Process 1) *1 Explicit VR Little Endian Explicit VR Big Endian Implicit VR Little Endian	1.2.840.10008.1.2.4.51 1.2.840.10008.1.2.4.70 1.2.840.10008.1.2.4.50 1.2.840.10008.1.2.1 1.2.840.10008.1.2.2 1.2.840.10008.1.2	SCU	None
RT Plan	1.2.840.10008.5.1.4.1.1.481.5	Explicit VR Little Endian Explicit VR Big Endian Implicit VR Little Endian	1.2.840.10008.1.2.1 1.2.840.10008.1.2.2 1.2.840.10008.1.2	SCU	None
Secondary Capture Image	1.2.840.10008.5.1.4.1.1.7	JPEG Lossy Extended *1 (Process 2 & 4) JPEG Lossless, Process 14 (selection value 1) JPEG Lossy Baseline (Process 1) *1 Explicit VR Little Endian Explicit VR Big Endian Implicit VR Little Endian	1.2.840.10008.1.2.4.51 1.2.840.10008.1.2.4.70 1.2.840.10008.1.2.4.50 1.2.840.10008.1.2.1 1.2.840.10008.1.2.2 1.2.840.10008.1.2	SCU	None
Ultra-Sound Multi-Frame Image	1.2.840.10008.5.1.4.1.1.3.1	JPEG Lossy Extended *1 (Process 2 & 4) JPEG Lossless, Process 14 (selection value 1) JPEG Lossy Baseline (Process 1) *1 Explicit VR Little Endian Explicit VR Big Endian Implicit VR Little Endian	1.2.840.10008.1.2.4.51 1.2.840.10008.1.2.4.70 1.2.840.10008.1.2.4.50 1.2.840.10008.1.2.1 1.2.840.10008.1.2.2 1.2.840.10008.1.2	SCU	None
Ultra-Sound Image	1.2.840.10008.5.1.4.1.1.6.1	JPEG Lossy Extended *1 (Process 2 & 4) JPEG Lossless, Process 14 (selection value 1) JPEG Lossy Baseline (Process 1) *1 Explicit VR Little Endian Explicit VR Big Endian Implicit VR Little Endian	1.2.840.10008.1.2.4.51 1.2.840.10008.1.2.4.70 1.2.840.10008.1.2.4.50 1.2.840.10008.1.2.1 1.2.840.10008.1.2.2 1.2.840.10008.1.2	SCU	None
X-Ray Angiographic Image	1.2.840.10008.5.1.4.1.1.12.1	JPEG Lossy Extended *1 (Process 2 & 4) JPEG Lossless, Process 14 (selection value 1) JPEG Lossy Baseline (Process 1) *1 Explicit VR Little Endian Explicit VR Big Endian Implicit VR Little Endian	1.2.840.10008.1.2.4.51 1.2.840.10008.1.2.4.70 1.2.840.10008.1.2.4.50 1.2.840.10008.1.2.1 1.2.840.10008.1.2.2 1.2.840.10008.1.2	SCU	None

Presentation Context Table					
Abstract Syntax		Transfer Syntax		Role	Ext. Neg.
Name	UID	Name List	UID List		
X-Ray RadioFluoroscopic Image	1.2.840.10008.5.1.4.1.1.12.2	JPEG Lossy Extended *1 (Process 2 & 4)	1.2.840.10008.1.2.4.51	SCU	None
		JPEG Lossless, Process 14 (selection value 1)	1.2.840.10008.1.2.4.70		
		JPEG Lossy Baseline (Process 1) *1	1.2.840.10008.1.2.4.50		
		Explicit VR Little Endian	1.2.840.10008.1.2.1		
		Explicit VR Big Endian	1.2.840.10008.1.2.2		
Implicit VR Little Endian	1.2.840.10008.1.2				
Waveform	1.2.840.10008.5.1.4.1.1.9.1.1	Explicit VR Little Endian Explicit VR Big Endian Implicit VR Little Endian	1.2.840.10008.1.2.1 1.2.840.10008.1.2.2 1.2.840.10008.1.2	SCU	None
Waveform 12-Lead ECG Object	1.2.840.10008.5.1.4.1.1.9.1.1	Explicit VR Little Endian Explicit VR Big Endian Implicit VR Little Endian	1.2.840.10008.1.2.1 1.2.840.10008.1.2.2 1.2.840.10008.1.2	SCU	None
Waveform General ECG Object	1.2.840.10008.5.1.4.1.1.9.1.2	Explicit VR Little Endian Explicit VR Big Endian Implicit VR Little Endian	1.2.840.10008.1.2.1 1.2.840.10008.1.2.2 1.2.840.10008.1.2	SCU	None
Waveform Ambulatory ECG Object	1.2.840.10008.5.1.4.1.1.9.1.3	Explicit VR Little Endian Explicit VR Big Endian Implicit VR Little Endian	1.2.840.10008.1.2.1 1.2.840.10008.1.2.2 1.2.840.10008.1.2	SCU	None
Waveform Hemodynamic Object	1.2.840.10008.5.1.4.1.1.9.2.1	Explicit VR Little Endian Explicit VR Big Endian Implicit VR Little Endian	1.2.840.10008.1.2.1 1.2.840.10008.1.2.2 1.2.840.10008.1.2	SCU	None
Waveform Cardiac Electro-physiology Object	1.2.840.10008.5.1.4.1.1.9.3.1	Explicit VR Little Endian Explicit VR Big Endian Implicit VR Little Endian	1.2.840.10008.1.2.1 1.2.840.10008.1.2.2 1.2.840.10008.1.2	SCU	None
Waveform Basic Audio Object	1.2.840.10008.5.1.4.1.1.9.4.1	Explicit VR Little Endian Explicit VR Big Endian Implicit VR Little Endian	1.2.840.10008.1.2.1 1.2.840.10008.1.2.2 1.2.840.10008.1.2	SCU	None
CSA Non-Image	1.3.12.2.1107.5.9.1	Implicit VR Little Endian Explicit VR Big Endian Explicit VR Little Endian	1.2.840.10008.1.2 1.2.840.10008.1.2.2 1.2.840.10008.1.2.1	SCU	None

*1: The Transfer Syntax used is strongly influenced by the fact of "how was the accepted Transfer Syntax at the time when the Instance was received". e.g. the Instances received with JPEG Lossy Transfer Syntaxes will not be converted and can only be sent out with the same Transfer Syntax.

Note: e.soft does not support any of the compression Transfer Syntaxes for NM or PT.

The proposed Transfer Syntax is highly restricted for images stored internally in lossy compressed format. E.g. instances received with JPEG Loss Transfer Syntaxes will not be converted and can only be sent out with the same Transfer Syntax.

The "MOVE destinations" must be configured as Storage destinations. This would include the configuration of Transfer Syntax capabilities.

Not all the listed transfer syntaxes will be proposed all the time. For some abstract syntaxes only a list of uncompressed (UC) transfer syntaxes (one or more) will be proposed, for other abstract syntaxes also JPEG Lossless (LL) syntax will be proposed and/or a list of JPEG Lossy (LY) transfer syntaxes. The contents of this lists is configurable, e.g. UC could be configured to contain only Implicit Little Endian for instance.

Depending on the real world activity initiating the C-STORE, we have the following behaviors:

- if the C-STORE is initiated by a user, a configuration parameter called QualityFactor(Q) will be used to decide which transfer syntax lists will be proposed. Q can take values between 0 and 100.

If Q=0, only UC will be proposed. If Q = 100, UC and LL will be proposed. Else UC and LY will be proposed.

- if the C-STORE is initiated by the C-MOVE SCP, there is another configuration parameter called Compression Types Supported (CTS) which will be used to decide what transfer syntaxes are proposed. CTS can take integer values. If CTS=0 or CTS > 3, UC will be proposed. If CTS=1, UC and LY will be proposed. If CTS = 2, UC and LL will be proposed. If CTS >= 3, UC, LL and LY will be proposed.

The compression types JPEG lossy and JPEG loss-less are parameters, which are part of the Application Entity Properties configuration (storage checked). It can be reached via the Service-UI: Configuration / DICOM / Network nodes. The e.soft product does not support compression transfer syntaxes for PT and NM modality types.

5.1.2.1.3 SOP specific Conformance to Storage SOP classes

The e.soft applications can create SC IOD type images when performing special applications that create Derived Images. The SC IOD will be a Standard Extended SC Storage SOP Class. The 3D viewing application is able to create further 2D (SC) images to document results from 3D processing. The e.soft (DICOM) application will not change private attributes as long as no modification is done. During a "Save as ..." operation all private attributes not defined within the e.soft DICOM application will be removed when the new object instance is created.

For association and DIMSE level time-outs, please refer to Configuration section of this document.

5.1.2.1.3.1 Optional Attributes

- Data Dictionary of DICOM Type 2 and 3 IOD Attributes

Please see the related Image Object definition tables in the Annex for a list of all DICOM IOD attributes of type 2 and 3, which are encoded by the e.soft applications.

5.1.2.1.3.2 Specialized Information Object Definitions

The DICOM images created by e.soft DICOM application conform to the DICOM IOD definitions (Standard extended IODs). But they will contain additional private elements, which have to be discarded by a DICOM system when modifying the image.

The DICOM nodes are responsible for data consistency when modifying images. All unknown private attributes have to be removed upon modification!

- Data Dictionary of applied private IOD Attributes

Please see "A.2 Siemens Standard Extended Modules" in the Annex for a list of possible private IOD attributes

5.1.3 Association Acceptance Policy

The e.soft DICOM application attempts to accept a new association for

- DIMSE C-ECHO
- DIMSE C-STORE

service operations. Any Information Objects transmitted on that association will be checked on conformance and stored in database if check was successful.

5.1.3.1 Associated Real-World Activity - Receive

5.1.3.1.1 Associated Real-World Activity – Receiving Images from a Remote Node

The daemon receiving process will accept an association and will receive any images transmitted on that association and will store the images on disk in the own database if the conformance check is performed successfully.

5.1.3.1.2 Accepted Presentation Context – Receiving Images

The e.soft DICOM application will accept Presentation Contexts as shown in the following table:

Presentation Context Table					
Abstract Syntax		Transfer Syntax		Role	Ext. Neg.
Name	UID	Name List	UID List		
Computed Radiography Image	1.2.840.10008.5.1.4.1.1.1	JPEG Lossy Extended (Process 2 & 4)	1.2.840.10008.1.2.4.51	SCP	None
		JPEG Lossless, Process 14 (selection value 1)	1.2.840.10008.1.2.4.70		
		JPEG Lossy Baseline (Process 1)	1.2.840.10008.1.2.4.50		
		RLE Lossless	1.2.840.10008.1.2.5		
		Explicit VR Little Endian	1.2.840.10008.1.2.1		
		Explicit VR Big Endian	1.2.840.10008.1.2.2		
		Implicit VR Little Endian	1.2.840.10008.1.2		
		Implicit VR Little Endian	1.2.840.10008.1.2		
Computed Tomography Image	1.2.840.10008.5.1.4.1.1.2	JPEG Lossy Extended (Process 2 & 4)	1.2.840.10008.1.2.4.51	SCP	None
		JPEG Lossless, Process 14 (selection value 1)	1.2.840.10008.1.2.4.70		
		JPEG Lossy Baseline (Process 1)	1.2.840.10008.1.2.4.50		
		RLE Lossless	1.2.840.10008.1.2.5		
		Explicit VR Little Endian	1.2.840.10008.1.2.1		
		Explicit VR Big Endian	1.2.840.10008.1.2.2		
		Implicit VR Little Endian	1.2.840.10008.1.2		
		Implicit VR Little Endian	1.2.840.10008.1.2		
Digital X-Ray Image	1.2.840.10008.5.1.4.1.1.1.1.1 1.2.840.10008.5.1.4.1.1.1.1	JPEG Lossy Extended (Process 2 & 4)	1.2.840.10008.1.2.4.51	SCP	None
		JPEG Lossless, Process 14 (selection value 1)	1.2.840.10008.1.2.4.70		
		JPEG Lossy Baseline (Process 1)	1.2.840.10008.1.2.4.50		
		RLE Lossless	1.2.840.10008.1.2.5		
		Explicit VR Little Endian	1.2.840.10008.1.2.1		
		Explicit VR Big Endian	1.2.840.10008.1.2.2		
		Implicit VR Little Endian	1.2.840.10008.1.2		
		Implicit VR Little Endian	1.2.840.10008.1.2		
MammoGraphy Image	1.2.840.10008.5.1.4.1.1.1.2.1 1.2.840.10008.5.1.4.1.1.1.2	JPEG Lossy Extended (Process 2 & 4)	1.2.840.10008.1.2.4.51	SCP	None
		JPEG Lossless, Process 14 (selection value 1)	1.2.840.10008.1.2.4.70		
		JPEG Lossy Baseline (Process 1)	1.2.840.10008.1.2.4.50		
		RLE Lossless	1.2.840.10008.1.2.5		
		Explicit VR Little Endian	1.2.840.10008.1.2.1		
		Explicit VR Big Endian	1.2.840.10008.1.2.2		
		Implicit VR Little Endian	1.2.840.10008.1.2		
		Implicit VR Little Endian	1.2.840.10008.1.2		
Digital Intra-oral X-Ray Image	1.2.840.10008.5.1.4.1.1.1.3.1 1.2.840.10008.5.1.4.1.1.1.3	JPEG Lossy Extended (Process 2 & 4)	1.2.840.10008.1.2.4.51	SCP	None
		JPEG Lossless, Process 14 (selection value 1)	1.2.840.10008.1.2.4.70		
		JPEG Lossy Baseline (Process 1)	1.2.840.10008.1.2.4.50		
		RLE Lossless	1.2.840.10008.1.2.5		
		Explicit VR Little Endian	1.2.840.10008.1.2.1		
		Explicit VR Big Endian	1.2.840.10008.1.2.2		
		Implicit VR Little Endian	1.2.840.10008.1.2		
		Implicit VR Little Endian	1.2.840.10008.1.2		

Presentation Context Table					
Abstract Syntax		Transfer Syntax		Role	Ext. Neg.
Name	UID	Name List	UID List		
Magnetic Resonance Image	1.2.840.10008.5.1.4.1.1.4	JPEG Lossy Extended (Process 2 & 4) JPEG Lossless, Process 14 (selection value 1) JPEG Lossy Baseline (Process 1) RLE Lossless Explicit VR Little Endian Explicit VR Big Endian Implicit VR Little Endian	1.2.840.10008.1.2.4.51 1.2.840.10008.1.2.4.70 1.2.840.10008.1.2.4.50 1.2.840.10008.1.2.5 1.2.840.10008.1.2.1 1.2.840.10008.1.2.2 1.2.840.10008.1.2	SCP	None
Nuclear Medicine Image	1.2.840.10008.5.1.4.1.1.20	Explicit VR Little Endian Explicit VR Big Endian Implicit VR Little Endian	1.2.840.10008.1.2.1 1.2.840.10008.1.2.2 1.2.840.10008.1.2	SCP	None
PET Image	1.2.840.10008.5.1.4.1.1.128	Explicit VR Little Endian Explicit VR Big Endian Implicit VR Little Endian	1.2.840.10008.1.2.1 1.2.840.10008.1.2.2 1.2.840.10008.1.2	SCP	None
RT Structure Set	1.2.840.10008.5.1.4.1.1.481.3	Explicit VR Little Endian Explicit VR Big Endian Implicit VR Little Endian	1.2.840.10008.1.2.1 1.2.840.10008.1.2.2 1.2.840.10008.1.2	SCP	None
RT Dose	1.2.840.10008.5.1.4.1.1.481.2	JPEG Lossy Extended (Process 2 & 4) JPEG Lossless, Process 14 (selection value 1) JPEG Lossy Baseline (Process 1) RLE Lossless Explicit VR Little Endian Explicit VR Big Endian Implicit VR Little Endian	1.2.840.10008.1.2.4.51 1.2.840.10008.1.2.4.70 1.2.840.10008.1.2.4.50 1.2.840.10008.1.2.1 1.2.840.10008.1.2.2 1.2.840.10008.1.2	SCP	None
RT Image	1.2.840.10008.5.1.4.1.1.481.1	JPEG Lossy Extended (Process 2 & 4) JPEG Lossless, Process 14 (selection value 1) JPEG Lossy Baseline (Process 1) RLE Lossless Explicit VR Little Endian Explicit VR Big Endian Implicit VR Little Endian	1.2.840.10008.1.2.4.51 1.2.840.10008.1.2.4.70 1.2.840.10008.1.2.4.50 1.2.840.10008.1.2.1 1.2.840.10008.1.2.2 1.2.840.10008.1.2	SCP	None
RT Plan	1.2.840.10008.5.1.4.1.1.481.5	Explicit VR Little Endian Explicit VR Big Endian Implicit VR Little Endian	1.2.840.10008.1.2.1 1.2.840.10008.1.2.2 1.2.840.10008.1.2	SCP	None
Secondary Capture Image	1.2.840.10008.5.1.4.1.1.7	JPEG Lossy Extended (Process 2 & 4) JPEG Lossless, Process 14 (selection value 1) JPEG Lossy Baseline (Process 1) RLE Lossless Explicit VR Little Endian Explicit VR Big Endian Implicit VR Little Endian	1.2.840.10008.1.2.4.51 1.2.840.10008.1.2.4.70 1.2.840.10008.1.2.4.50 1.2.840.10008.1.2.5 1.2.840.10008.1.2.1 1.2.840.10008.1.2.2 1.2.840.10008.1.2	SCP	None
Ultra-Sound Multi-Frame Image (retired) *1	1.2.840.10008.5.1.4.1.1.3	JPEG Lossy Extended (Process 2 & 4) JPEG Lossless, Process 14 (selection value 1) JPEG Lossy Baseline (Process 1) RLE Lossless Explicit VR Little Endian Explicit VR Big Endian Implicit VR Little Endian	1.2.840.10008.1.2.4.51 1.2.840.10008.1.2.4.70 1.2.840.10008.1.2.4.50 1.2.840.10008.1.2.5 1.2.840.10008.1.2.1 1.2.840.10008.1.2.2 1.2.840.10008.1.2	SCP	None

Presentation Context Table					
Abstract Syntax		Transfer Syntax		Role	Ext. Neg.
Name	UID	Name List	UID List		
Ultra-Sound Image (retired) *1	1.2.840.10008.5.1.4.1.1.6	JPEG Lossy Extended (Process 2 & 4) JPEG Lossless, Process 14 (selection value 1) JPEG Lossy Baseline (Process 1) RLE Lossless Explicit VR Little Endian Explicit VR Big Endian Implicit VR Little Endian	1.2.840.10008.1.2.4.51 1.2.840.10008.1.2.4.70 1.2.840.10008.1.2.4.50 1.2.840.10008.1.2.5 1.2.840.10008.1.2.1 1.2.840.10008.1.2.2 1.2.840.10008.1.2	SCP	None
Ultra-Sound Multi-Frame Image	1.2.840.10008.5.1.4.1.1.3.1	JPEG Lossy Extended (Process 2 & 4) JPEG Lossless, Process 14 (selection value 1) JPEG Lossy Baseline (Process 1) RLE Lossless Explicit VR Little Endian Explicit VR Big Endian Implicit VR Little Endian	1.2.840.10008.1.2.4.51 1.2.840.10008.1.2.4.70 1.2.840.10008.1.2.4.50 1.2.840.10008.1.2.5 1.2.840.10008.1.2.1 1.2.840.10008.1.2.2 1.2.840.10008.1.2	SCP	None
Ultra-Sound Image	1.2.840.10008.5.1.4.1.1.6.1	JPEG Lossy Extended (Process 2 & 4) JPEG Lossless, Process 14 (selection value 1) JPEG Lossy Baseline (Process 1) RLE Lossless Explicit VR Little Endian Explicit VR Big Endian Implicit VR Little Endian	1.2.840.10008.1.2.4.51 1.2.840.10008.1.2.4.70 1.2.840.10008.1.2.4.50 1.2.840.10008.1.2.5 1.2.840.10008.1.2.1 1.2.840.10008.1.2.2 1.2.840.10008.1.2	SCP	None
X-Ray Angiographic Image	1.2.840.10008.5.1.4.1.1.12.1	JPEG Lossy Extended (Process 2 & 4) JPEG Lossless, Process 14 (selection value 1) JPEG Lossy Baseline (Process 1) RLE Lossless Explicit VR Little Endian Explicit VR Big Endian Implicit VR Little Endian	1.2.840.10008.1.2.4.51 1.2.840.10008.1.2.4.70 1.2.840.10008.1.2.4.50 1.2.840.10008.1.2.5 1.2.840.10008.1.2.1 1.2.840.10008.1.2.2 1.2.840.10008.1.2	SCP	None
X-Ray RadioFluoroscopic Image	1.2.840.10008.5.1.4.1.1.12.2	JPEG Lossy Extended (Process 2 & 4) JPEG Lossless, Process 14 (selection value 1) JPEG Lossy Baseline (Process 1) RLE Lossless Explicit VR Little Endian Explicit VR Big Endian Implicit VR Little Endian	1.2.840.10008.1.2.4.51 1.2.840.10008.1.2.4.70 1.2.840.10008.1.2.4.50 1.2.840.10008.1.2.5 1.2.840.10008.1.2.1 1.2.840.10008.1.2.2 1.2.840.10008.1.2	SCP	None
Waveform	1.2.840.10008.5.1.4.1.1.9.1.1 1.2.840.10008.5.1.4.1.1.9.1.2 1.2.840.10008.5.1.4.1.1.9.1.3 1.2.840.10008.5.1.4.1.1.9.2.1 1.2.840.10008.5.1.4.1.1.9.3.1 1.2.840.10008.5.1.4.1.1.9.4.1	Explicit VR Little Endian Explicit VR Big Endian Implicit VR Little Endian	1.2.840.10008.1.2.1 1.2.840.10008.1.2.2 1.2.840.10008.1.2	SCP	None
CSA Non-Image Storage	1.3.12.2.1107.5.9.1	Implicit VR Little Endian Explicit VR Big Endian Explicit VR Little Endian	1.2.840.10008.1.2 1.2.840.10008.1.2.2 1.2.840.10008.1.2.1	SCP	None
Verification	1.2.840.10008.1.1	Implicit VR Little Endian Explicit VR Big Endian Explicit VR Little Endian	1.2.840.10008.1.2 1.2.840.10008.1.2.2 1.2.840.10008.1.2.1	SCP	None

*1) US Retired and US Multi-frame Retired images are converted to US Images/US Multi-frame images before storing them into the local database. The conversion creates new images, which implies new UIDs.

Note:

With RLE Lossless Transfer Syntax the DICOM application will decompress the image before storing it into the database.

e.soft does not support any of the compression Transfer Syntaxes for NM or PT.

5.1.3.1.3 SOP-specific Conformance Statement – Receiving Images

The e.soft DICOM application conforms to the Full Storage Class at Level 2.

Upon successful receiving a C-STORE-RQ, the e.soft DICOM receiver performs a quick plausibility test on the received image and available system resources. If this test succeeds, it returns the status SUCCESS, otherwise one of the following status codes is returned and the association is aborted:

- Refused (A700):
This error status indicates a lack of Resources (e.g. not enough disk space) on the e.soft modality.
- Invalid Dataset (0xA900):
The dataset is not containing one of the Attributes “Study Instance UID”, “Series Instance UID” or “SOP Instance UID”, or one of them has an invalid value.
- Processing Error (0110):
An error occurred while processing the image, which makes it impossible to proceed

Attention! Only after sending the response, the image will be saved into the database. If during this operation an error occurs, the association will be aborted. This implies that a C-STORE-RSP with status SUCCESS does not mean that the image was successfully stored into the database.

In order to confirm that the sent images were successfully stored in the database, the sending application should use Storage Commitment Service.

If an image instance is received that is identified by a SOP Instance UID which is already used by an Instance stored in database then the actual received image will be discarded. The existing Instance is not superseded.

The following sections will differentiate the attribute contents required for Image Viewing. The e.soft DICOM application supports more formats for Storage of Images than Viewing.

5.1.3.1.3.1 Image Pixel Attribute Acceptance Criterion for Grayscale Images - Viewing

The e.soft Multi-Modality Viewing application accepts the MONOCHROME1 and MONOCHROME2 photometric interpretation pixel format and graphic overlay with unsigned integer and 8 or 16 bits allocated. Accepted values:

- Pixel plane
 - samples per pixel (attribute 0028, 0002) = 1
 - photometric interpretation (attribute 0028,0004) = “MONOCHROME1”
 - photometric interpretation (attribute 0028,0004) = “MONOCHROME2”
 - pixel representation (attribute 0028, 0103) = 0
 - bits allocated (attribute 0028, 0100) = 8, 16
 - bits stored (attribute 0028,0101) = 8, 10, 12
 - high bit (attribute 0028,0102) = 7, 9, 11
 - only aspect ratio 1:1 is supported
- Overlay plane
 - overlay type (attribute 60xx, 0040) = “G”

- bits allocated (attribute 60xx, 0100) = 16
- bit position (attribute 60xx, 0102) = 12, 13, 14, 15 (only bits above high bit permitted)
- Graphic Overlay will be shifted to fill Overlay Planes from Bit 12 and consecutive.
- Overlay plane
 - overlay type (attribute 60xx, 0040) = "G"
 - bits allocated (attribute 60xx, 0100) = 1
 - bit position (attribute 60xx, 0102) = 0
 - overlay data (attribute 60xx, 3000) = supported

The e.soft Multi -Modality Viewing application accepts also the MONOCHROME1 and MONOCHROME2 photometric interpretation pixel format with binary 2's complement integer and 16 bits allocated. Accepted values:

- Pixel plane
 - samples per pixel (attribute 0028, 0002) = 1
 - photometric interpretation (attribute 0028,0004) = "MONOCHROME1"
 - photometric interpretation (attribute 0028,0004) = "MONOCHROME2"
 - pixel representation (attribute 0028, 0103) = 1 (signed)
 - bits allocated (attribute 0028, 0100) = 16
 - bits stored (attribute 0028,0101) = 16
 - high bit (attribute 0028,0102) = 15
 - only aspect ratio 1:1 is supported
 - Overlay plane
 - overlay type (attribute 60xx, 0040) = "G"
 - bits allocated (attribute 60xx, 0100) = 1
 - bit position (attribute 60xx, 0102) = 0
 - overlay data (attribute 60xx, 3000) = supported
 - For MOD LUT, both the linear LUT (Rescale Slope/Intercept) and the MOD LUT SQ are supported and considered when pixel data is displayed. However there are two limitations. The MOD LUT SQ will be ignored in the following cases:
 - 8-Bit signed pixels
 - the pixel format is changed by the MOD LUT (e.g. 8bit -> 16bit)
- If the MOD LUT SQ contains multiple LUTs, then only the first one is used.

For VOI LUT, both the linear LUT (Window Center/Width) and the VOI LUT SQ are supported (VOI LUT SQ with 8 or 16 bit LUT data)

But if both, a VOI LUT SQ and a linear MOD LUT, are specified within one image, then the value for Rescale Slope is restricted to 1.

If the VOI LUT SQ contains multiple LUTs, then only the first one is used by default. The other VOI LUTs are selectable.

Only Rectangular and Circular Shutter Shape is supported in this version. Images containing other Shutter Shapes will be displayed w/o shutter.

5.1.3.1.3.2 Image Pixel Attribute Acceptance Criterion for Color Images - Viewing

The e.soft Multi -Modality Viewing application supports the RGB color image description with the unsigned integer 24-bit color image plane pixel format. Accepted values:

- samples per pixel (attribute 0028, 0002) = 3
- photometric interpretation (attribute 0028,0004) = "RGB"
- pixel representation (attribute 0028, 0103) = 0
- bits allocated (attribute 0028, 0100) = 8
- bits stored (attribute 0028,0101) = 8
- high bit (attribute 0028,0102) = 7
- planar configuration (attribute 0028,0006) = 0 (pixel interleave) or 1 (plane interleave).

The e.soft Multi -modality Viewing application supports the "Palette Cdor" color image description with the unsigned integer and 2's complement pixel format. Accepted values:

- samples per pixel (attribute 0028, 0002) = 1
- photometric interpretation (attribute 0028,0004) = "PALETTE COLOR"
- pixel representation (attribute 0028, 0103) = 0
- bits allocated (attribute 0028, 0100) = 8 and bits stored (attribute 0028,0101) = 8
- bits allocated (attribute 0028, 0100) = 16 and bits stored (attribute 0028,0101) = 16
- high bit (attribute 0028,0102) = 7, 15

Both 8-bit and 16-bit palettes are supported, but NO Segmented Palette Color LUTs.

The e.soft Multi -modality Viewing application supports the YBR_FULL color image description with the unsigned integer pixel format. Accepted values:

- samples per pixel (attribute 0028, 0002) = 3
- photometric interpretation (attribute 0028,0004) = "YBR_FULL"
- pixel representation (attribute 0028, 0103) = 0
- bits allocated (attribute 0028, 0100) = 8 and bits stored (attribute 0028,0101) = 8
- high bit (attribute 0028,0102) = 7

If e.soft software is making any persistent changes on a YBR image, the resulting new image will be saved with Photometric Interpretation = "RGB".

5.1.3.1.4 Presentation Context Acceptance Criterion

The e.soft DICOM application will accept any number of verification or storage SOP classes that are listed above. The number of presentation contexts accepted is limited to the maximum of 127 (DICOM limit). In the event that the e.soft DICOM application runs out of resources, it will reject the association request.

5.1.3.1.5 Transfer Syntax Selection Policies

The e.soft DICOM application does not support compression transfer syntaxes for the following image types: NM and PT

The e.soft DICOM application currently supports

- the Implicit VR Little Endian, the Explicit VR Little Endian and Explicit VR Big Endian Transfer Syntaxes
- the JPEG Lossless Non-hierarchical Transfer Syntax
- the JPEG Baseline and JPEG Extended Transfer Syntaxes (JPEG Lossy).
- the RLE Lossless Transfer Syntax

Any proposed presentation context including one of these Transfer Syntaxes will be accepted. Any proposed presentation context that does not include one of these Transfer Syntaxes will be rejected.

The order of preference in accepting Transfer Syntaxes within Presentation Contexts or Presentation Contexts with single Transfer Syntaxes is:

1. JPEG Lossy Extended
2. JPEG Lossless non-hierarchical
3. JPEG Lossy Baseline
4. RLE Lossless
5. Explicit VR Little Endian
6. Explicit VR Big Endian
7. Implicit VR Little Endian

With RLE Lossless Transfer Syntax the e.soft DICOM application will decompress the image before storing it into the database.

With Implicit VR Little Endian Transfer Syntax the e.soft DICOM application will remove any Private Attributes not known to the application. Decision on removal of a Private Element is done if there is NO entry in the attribute-dictionary of the e.soft DICOM application.

Therefore any Explicit VR Transfer Syntax shall preferably be used by the Storage SCU's when sending Composite Image Instances to the e.soft DICOM application.

6 Implementation Model Storage Commitment

The Storage Commitment service class defines an application-level class of service which facilitates the commitment to storage. It performs an additional task of commitment of composite objects apart from the network based storage of images as defined by the Storage Service class. The e.soft DICOM implementation supports the Storage Commitment Push Model as SCU and SCP.

6.1 Application Data Flow Diagram

The e.soft DICOM network implementation acts as SCU/SCP for the Storage Commitment Push Model Service using the Storage Commitment Service Class. The product target Operating System is Microsoft Windows XP Professional

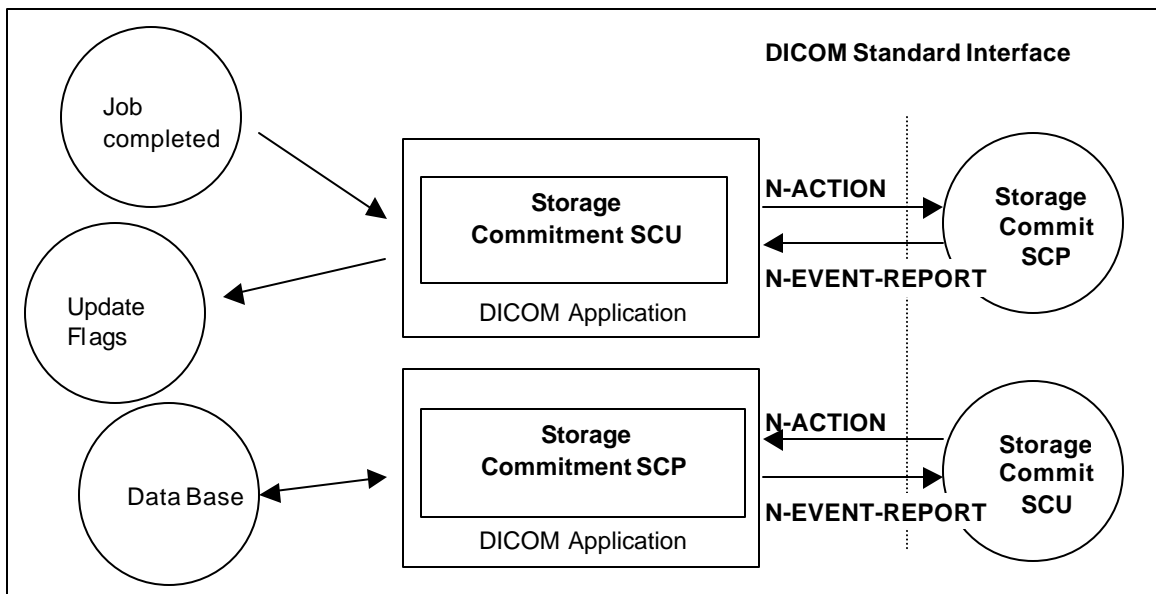

Figure 3: Application Data Flow Diagram – Storage Commitment SCU/SCP

6.2 Functional Definitions of Application Entities

With each successfully completed send job, the e.soft DICOM Application will create a Storage Commitment Push Model Identifier from the SOP Instances sent. Then an a Storage Commit Request is triggered. Depending on configuration, the e.soft DICOM application will keep the association open for responses with a configurable time-out, or closes the association and expects responses on a different association that has to be establishes by the remote Storage Commitment SCP.

The commitment status derived from the related trigger response will be indicated in the related Status Flags of the related entity. It is possible to create triggers ("auto rules") from this event.

The Transaction UIDs of the pending commitment request are kept "open" for a configurable amount in time (default: 1h). If the "open time" for a pending commitment request has elapsed w/o a related response from the provider, the Transaction UID is removed and the related entities are indicated as "commit failed".

In any case, commitment will only be requested for previously and successfull y sent images.

The Storage Commitment SCP is running in background and is ready to receive request when the system is started.

6.3 Sequencing of real World Activities

The Storage Commitment trigger is automatically derived from the successful completion of a Send Job.

7 AE Specification Storage Commitment

7.1 Storage Commitment AE Specification

e.soft provides Standard Conformance to the following DICOMV3.0SOPClass as an SCU and SCP:

SOP Class Name	SOP Class UID
Storage Commitment Push Model	1.2.840.10008.1.20.1

7.1.1 Association Establishment Policies

7.1.1.1 General

With a Send Job successfully completed, the DICOM application will generate an Storage Commitment Identifier which references to all Instances of the processed job. The Commit Request is then sent over a single opened association. The e.soft will wait for Status responses of the Storage Commitment Request. If the Provider accepts the Storage Commitment with Success Status, the generated Transaction UID, together with study identification data and a time-stamp, is kept. Depending on configuration, the association is closed when the configured time-out has elapsed or a response was received before. If the association is closed before a response was received, the response is then expected on a different association. Multiple Storage Commitment Requests can be pending. The default PDU size used will be 256 KB.

7.1.1.2 Number of Associations

The e.soft DICOM application initiates several associations at a time, one for each destination to which a transfer request is being processed in the active job queue list.

The e.soft DICOM application is able to accept multiple associations at a time. It can handle up to 10 associations in parallel.

7.1.1.3 Asynchronous Nature

The e.soft DICOM software does not support asynchronous communication (multiple outstanding transactions over a single association).

7.1.1.4 Implementation Identifying Information

Implementation Class UID	1.3.12.2.1107.5.9.20000101
Implementation Version Name	SIEMENS_SWFVD20K

7.1.2 Association Initiation Policy

The e.soft DICOM Application Entity acts as a Service Class User (SCU) for the

- Storage Commitment Push Model Service Class (to request commitment for storage of instances previously sent).
To do so, the e.soft will issue a
 - N-ACTION DIMSE to request commitment or a
 - N-EVENT-REPORT DIMSE to respond to a received storage commitment request and the association was closed by the remote system prior to response.

7.1.2.1 Real World Activity – Storage Commitment

7.1.2.1.1 Associated Real-World Activity - Job Completed

The e.soft Storage Commitment application sends the commit request (N-ACTION-RQ) message and waits for acceptance of this request (N-ACTION-RSP). After receiving this, the transaction is marked as “waiting”.

Depending on a configuration value, the association will then be closed or kept open. In the first case, there is another configurable timeout giving the number of hours (h) and minutes (m) (by default 1h:0m) to wait for the corresponding commit response (N-EVENT-REPORT). In the second case, this time is the (also configurable) time-out for the association. For both cases, if the commit response (N-EVENT-REPORT) does not arrive during the configured time, the transaction will be marked as failed. The e.soft does not re-send objects from a failed Storage Commitment result in any case.

If the commit response (N-EVENT-REPORT) received has the status of “complete- failure exists”, the transaction is marked as failed, else the transaction is marked as “completed”; In both cases, a message is shown to the user.

7.1.2.1.2 Proposed Presentation Contexts - Job Completed

The e.soft DICOM application will propose Presentation Contexts as shown in the following table:

Presentation Context Table					
Abstract Syntax		Transfer Syntax		Role	Ext. Neg.
Name	UID	Name List	UID List		
Storage Commitment Push Model	1.2.840.10008.1.20.1	Implicit VR Little Endian Explicit VR Little Endian Explicit VR Big Endian	1.2.840.10008.1.2 1.2.840.10008.1.2.1 1.2.840.10008.1.2.2	SCU	None

7.1.2.1.3 SOP Specific Conformance Statement- Job Completed

Storage Commitment is supported for all the SOPclass UIDs as mentioned in 'Acceptable presentation contexts - Storage' in the Storage SCP section of this document.

The Referenced Study Component Sequence is not supported.

Storage Media File-Set ID and UID Attributes will not be supported in the commitment request (N-ACTION primitive) invoked by the Storage Commitment SCU.

7.1.2.1.4 Associated Real-World Activity - Send Commit Response

Acting as an Storage Commitment Provider, the e.soft Storage Commitment AE received an Storage Commitment request, carried out the request, and is ready to send back the response, but the association is not open anymore. In this case it will by itself initiate an association to send the storage commitment response (N-EVENT-REPORT) to the SCU.

7.1.2.1.5 Proposed Presentation Contexts - Send Commitment Response

The e.soft DICOM application will propose Presentation Contexts as shown in the following table:

Presentation Context Table					
Abstract Syntax		Transfer Syntax		Role	Ext. Neg.
Name	UID	Name List	UID List		
Storage Commitment Push Model	1.2.840.10008.1.20.1	Implicit VR Little Endian Explicit VR Little Endian Explicit VR Big Endian	1.2.840.10008.1.2 1.2.840.10008.1.2.1 1.2.840.10008.1.2.2	SCP	None

7.1.2.1.6 SOP Specific Conformance Statement - Send Commitment Response

Storage Media File-Set ID and UID Attributes will not be supported in the N-EVENT-REPORT primitive invoked by the Storage Commitment SCP.

7.1.3 Association Acceptance Policy

The e.soft DICOM Application Entity acts as a Service Class Provider (SCP) for the

- Storage Commitment Push Model Service Class (Give a commitment to store previously received instances).

To do so, the e.soft attempts to accept a

- N-ACTION DIMSE to receive a commitment request for the instance included or a
- N-EVENT-REPORT DIMSE to receive a storage commitment response from a previous request and the SCP behavior requires a different association than the commit request.

7.1.3.1 Associated Real-World Activity - Commit SCP

7.1.3.1.1 Associated Real-World Activity - Receive Commit Request

When receiving an Storage Commitment request the e.soft DICOM application will perform the necessary steps to check the received list Instances against the local database or, if configured, check the Instances with the attached archive system.

7.1.3.1.2 Accepted Presentation Contexts - Receive Commit Request

The e.soft DICOM application will accept Presentation Contexts as shown in the following table:

Presentation Context Table					
Abstract Syntax		Transfer Syntax		Role	Ext. Neg.
Name	UID	Name List	UID List		
Storage Commitment Push Model	1.2.840.10008.1.20.1	Implicit VR Little Endian Explicit VR Little Endian Explicit VR Big Endian	1.2.840.10008.1.2 1.2.840.10008.1.2.1 1.2.840.10008.1.2.2	SCP	None

7.1.3.1.3 SOP-specific Conformance Statement - Receive Commit Request

The e.soft Storage Commitment DICOM Application can be configured to run on an archive system.

If the Storage Commitment Application is running on an archive system, it will interact with this archive system in order to commit the storage of images and will send back to the SCU the result of the operation.

If not running on an archive node, the e.soft Storage Commitment AE will return success for images that are stored in the local database and failure for images that are not. However, the committed images can later be deleted by the user on the SCP side!

Remark: When not running on an archive system, sending data with Storage Commitment via network is a safe data transfer but does not fulfill the regulatory requirements of long term archiving, objects with the "committed" flag may be deleted by the user.

7.1.3.2 Associated Real-World Activity - Commit SCU

7.1.3.2.1 Associated Real-World Activity - Update Flags

The e.soft Storage Commitment DICOM Application has sent a Storage Commitment Request and, being configured to receive response on a separate association, has closed the association, and now it gets an association request from the Storage Commitment SCP that want to send the results. The e.soft DICOM application will await Storage commitment Notification triggers. Any incoming Notification will be checked for validity, that is, if the related Transaction UID is still part of the Pending Request Queue.

If the Notification is valid, the Notification Identifier is evaluated and the related Instances marked with the related status. The over-all Commit Status of the higher Information Entities is derived from propagation of the States of all Image entities included in a study.

The Status Flags directly affected by Storage Commitment results and indicated in the different entities of the Patient Browser list can be one of

- "AC" or "SC" - Successful Commitment, A means archived to configured Archive destination, whereas S means sent to any other destination
- "Af" or "Sf" - Commitment failed.
- "A?" or "S?" - Commitment request is sent, response is pending.

In case of failure the user has to repeat the transfer of images to the Archive destination. Another Storage Commitment will be performed after sending is completed successfully.

7.1.3.2.2 Accepted Presentation Contexts - Update Flags

The e.soft DICOM application will accept Presentation Contexts as shown in the following table:

Presentation Context Table					
Abstract Syntax		Transfer Syntax		Role	Ext. Neg.
Name	UID	Name List	UID List		
Storage Commitment Push Model	1.2.840.10008.1.20.1	Implicit VR Little Endian Explicit VR Little Endian Explicit VR Big Endian	1.2.840.10008.1.2 1.2.840.10008.1.2.1 1.2.840.10008.1.2.2	SCU	None

7.1.3.2.3 SOP-specific Conformance Statement - Update Flags

If the Commitment response (N-EVENT-REPORT) received has the status of “complete - failure exists”, the transaction is marked as failed, else the transaction is marked as “completed”; In both cases, a message is shown to the user.

The related status flags are set for the committed images in the local database.

The e.soft DICOM application will NOT support the Storage Media File Set ID attributes.

8 Implementation Model Query / Retrieve

The query/retrieve service class defines an application -level class of services which facilitates the management of images and patient data against the well-defined information model of DICOM and allows a DICOM AE to retrieve images from a remote DICOM node or to request a remote DICOM AE to initiate a transfer of images to another DICOM AE. The e.soft DICOM query/retrieve application supports the query/retrieve services to act as SCU and SCP.

8.1 Application Data Flow Diagram

The e.soft DICOM network implementation acts as SCU and SCP for the query/retrieve network service. The product target Operating System is Microsoft Windows XP Professional

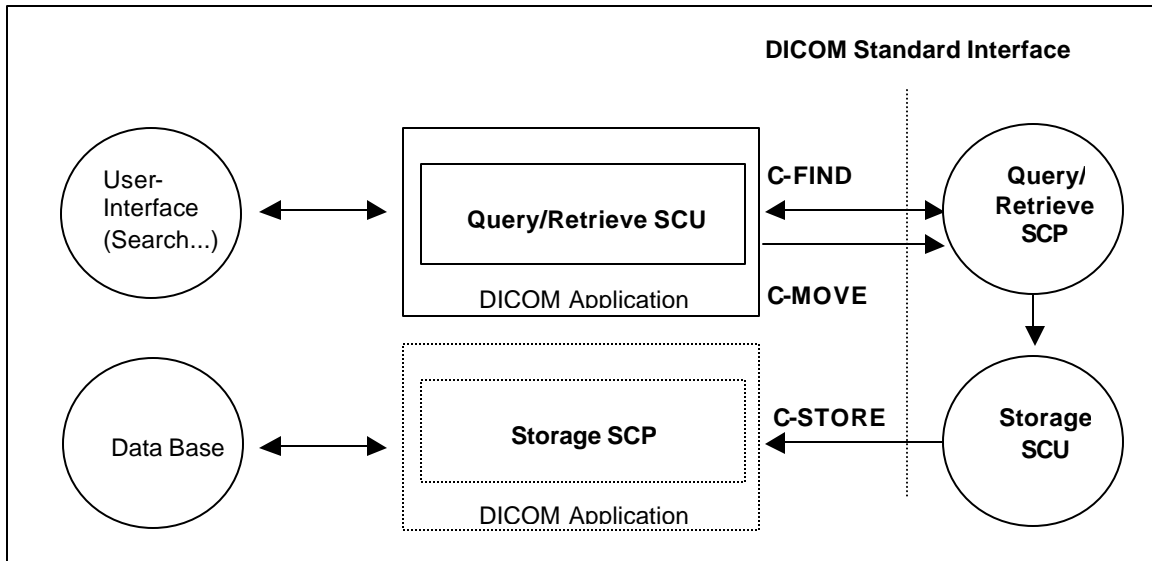

Figure 4: e.soft Application Data Flow Diagram – Query/Retrieve SCU

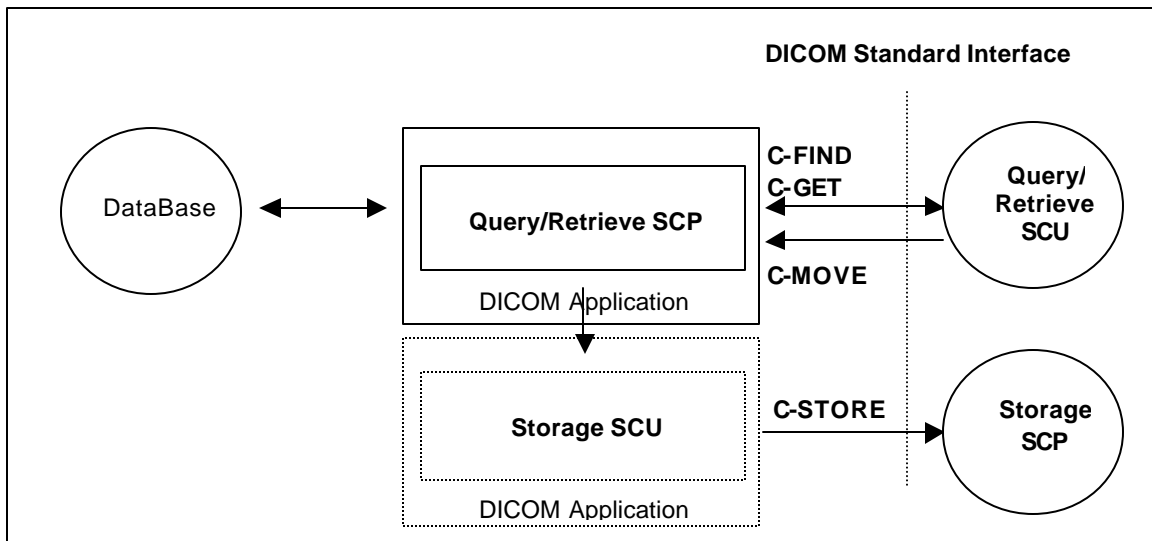

Figure 5: e.soft Application Data Flow Diagram – Query/Retrieve SCP

8.2 Functional Definitions of Application Entities

The e.soft DICOM query/retrieve SCU requests the remote query/retrieve SCP to perform a search and match to the keys specified in the request in order to display the results in the e.soft user interface. Depending on user action (Import) the e.soft DICOM SCU sends a C-MOVE DIMSE service to initiate a C-STORE sub-operation on the SCP to start an image transfer from remote Storage SCU (running on Query/Retrieve SCP) to the e.soft Storage SCP.

The e.soft DICOM query/retrieve SCP responds to C-FIND DIMSE services from remote SCU applications. Depending on further remote request, a C-GET or a C-MOVE involves the e.soft DICOM query/retrieve SCP application to initiate a C-STORE association (by triggering and parameterize the own Storage SCU) to send image objects to a remote Storage SCP.

All components of the DICOM query/retrieve SCP application are operating as background server processes. They are existing when the machine is powered on and then respond to queries based on the records stored in its database.

8.3 Sequencing of Real-World Activities

Retrieve of images is only possible if results from a previous "Search..." operation exist and those entities can be selected for "Import".

9 Application Entity Specification Query/Retrieve

9.1 Query/Retrieve Service AEs Specification

The Query/Retrieve SCU requests that the remote SCP performs a match of all keys specified in the request, against the information in its database and the identified images will be moved over a different (C-MOVE) storage association.

The Query/Retrieve SCP responds to queries based on the records based on its database and images will be sent to the requesting SCU or to a different storage destination.

e.soft provides Standard Conformance to the following DICOM V3.0 SOP Classes as SCU:

SOP Class Name	SOP Class UID
Patient Root Query/Retrieve Information Model- FIND	1.2.840.10008.5.1.4.1.2.1.1
Patient Root Query/Retrieve Information Model- MOVE	1.2.840.10008.5.1.4.1.2.1.2
Study Root Query/Retrieve Information Model- FIND	1.2.840.10008.5.1.4.1.2.2.1
Study Root Query/Retrieve Information Model- MOVE	1.2.840.10008.5.1.4.1.2.2.2

e.soft provides Standard Conformance to the following DICOM V3.0 SOP Classes as an SCP:

SOP Class Name	SOP Class UID
Patient Root Query/Retrieve Information Model- FIND	1.2.840.10008.5.1.4.1.2.1.1
Patient Root Query/Retrieve Information Model- MOVE	1.2.840.10008.5.1.4.1.2.1.2
Patient Root Query/Retrieve Information Model- GET	1.2.840.10008.5.1.4.1.2.1.3
Study Root Query/Retrieve Information Model- FIND	1.2.840.10008.5.1.4.1.2.2.1
Study Root Query/Retrieve Information Model- MOVE	1.2.840.10008.5.1.4.1.2.2.2
Study Root Query/Retrieve Information Model- GET	1.2.840.10008.5.1.4.1.2.2.3
Patient/Study Only Query/Retrieve Information Model - FIND	1.2.840.10008.5.1.4.1.2.3.1
Patient/Study Only Query/Retrieve Information Model- MOVE	1.2.840.10008.5.1.4.1.2.3.2
Patient/Study Only Query/Retrieve Information Model- GET	1.2.840.10008.5.1.4.1.2.3.3

Note: See also the Storage DICOM Conformance Statement of the e.soft DICOM application to compare for conformance of the C-STORE sub-operation generated by the C-GET or C-MOVE DIMSE services. Furthermore compare the supported Storage Service SOP classes described in the Storage DICOM Conformance Statement of the Modality to which the images shall be transferred to.

9.1.1 Association Establishment Policies

9.1.1.1 General

With the “Search...” function the query data are input and the DICOM query/retrieve application is started. A query request will be sent out to one remote node that can be selected from a list of configured Query Providers and the response data will be displayed for the user. Upon request (Import), the retrieval of selected items is initiated. The default PDU size used will be 256 KB.

9.1.1.2 Number of Associations

The e.soft DICOM application initiates several associations at a time, one for each destination to which a transfer request is being processed in the active job queue list.

The e.soft DICOM application is able to accept multiple associations at a time. It can handle up to 10 associations in parallel.

9.1.1.3 Asynchronous Nature

The e.soft DICOM software does not support asynchronous communication (multiple outstanding transactions over a single association).

9.1.1.4 Implementation Identifying Information

Implementation Class UID	1.3.12.2.1107.5.9.20000101
Implementation Version Name	SIEMENS_SWFVD20K

9.1.2 Association Initiation Policy

The query user interface will request the query-data from user and triggers one C-FIND request to the selected remote node. The response data will be displayed in the query UI for further data navigation.

When requesting Import of related items the browser requests the retrieve application to send a C-MOVE request to the related remote node. Images will then be received by the Storage SCP as described in the related section.

9.1.2.1 Real World Activity - Find SCU

9.1.2.1.1 Associated Real-World Activity - Find SCU “Search”

The associated Real-World activity is to fill out a query form with search data and pass it as query to the network application which issues a C-FIND over a previously built association. The remote SCP will respond with related data-entries that will be passed to a browser application. When data transfer is finished the association is closed.

9.1.2.1.2 Proposed Presentation Contexts - Find SCU

The e.soft/syngo DICOM application will propose Presentation Contexts as shown in the following table:

Presentation Context Table					
Abstract Syntax		Transfer Syntax		Role	Ext. Neg.
Name	UID	Name List	UID List		
Patient Root Query/Retrieve Model - FIND	1.2.840.10008.5.1.4.1.2.1.1	Implicit VR Little Endian Explicit VR Little Endian Explicit VR Big Endian	1.2.840.10008.1.2 1.2.840.10008.1.2.1 1.2.840.10008.1.2.2	SCU	None
Study Root Query/Retrieve Model – FIND	1.2.840.10008.5.1.4.1.2.2.1	Implicit VR Little Endian Explicit VR Little Endian Explicit VR Big Endian	1.2.840.10008.1.2 1.2.840.10008.1.2.1 1.2.840.10008.1.2.2	SCU	None

It is configurable which of the two query models (or both) are to be used by the e.soft DICOM syngo Query SCU application. If both Abstract Syntaxes are configured, The C-FIND SCU will use the Patient Root Model only for C-FIND requests on PATIENT level. For all other levels it will use the STUDY root model.

9.1.2.1.3 Conformance Statement – syngo Find SCU

The e.soft DICOM syngo Query/Retrieve SCU supports hierarchical queries with all mandatory search keys. The interactive querying of attributes on IMAGE level is not supported by the Query SCU, hence retrieval of individual Objects is possible. The following table describes the search keys for the different query models that the SCU supports. Matching is either wildcard, which means that the user can supply a string containing wildcards, or universal, which means that the attribute is requested as return value.

Attribute name	Tag	Type	Matching	User input	return value display
Patient Level^a					
Patient Name	(0010,0010)	R	Wildcard ^b	enter value	yes
Patient ID	(0010,0020)	U	Wildcard ^b	enter value	yes
Patient's Birth date	(0010,0030)	O	universal (Null)	enter value	yes
Patient's Sex	(0010,0040)	O	universal (Null)	enter value	yes
Number of Patient related Studies	(0020,1200)	O	universal (Null)	-	yes ^c
Number of Patient related Series	(0020,1202)	O	universal (Null)	-	no
Number of Patient related Instances	(0020,1204)	O	universal (Null)	-	no
Study Level					
Patient Named	(0010,0010)	R	Wildcard ^b	enter value	yes
Patient ID	(0010,0020)	R	Wildcard ^b	enter value	yes
Patient's Birth date ^d	(0010,0030)	O	universal (Null)	enter value	yes
Patient's Sex ^d	(0010,0040)	O	universal (Null)	enter value	yes
Study Instance UID	(0020,000D)	U	single value	-	yes
Study ID	(0020,0010)	R	universal (Null)	enter value	yes
Study Date	(0008,0020)	R	universal (Null)	enter value ^e	yes
Study Time	(0008,0030)	R	universal (Null)	-	yes
Accession Number	(0008,0050)	R	universal (Null)	-	yes
Study Description	(0008,1030)	O	universal (Null)	-	yes
Referring Physician's Name	(0008,0090)	O	universal (Null)	-	yes
Name of Physician Reading Study	(0008,1060)	O	universal (Null)	-	yes
Modalities in Study	(0008,0061)	O	universal (Null)	-	yes
Storage Media File-Set ID	(0008,0130)	O	universal (Null)	-	no
Retrieve AE Title	(0008,0054)	O	universal (Null)	-	no
Number of Study related Series	(0020,1206)	O	universal (Null)	-	yes ^f

^a Patient Root Information Model only

^b Always a '*' is appended to the user-supplied string

^c Implicitly visualized in the UI if no study and series search attributes have been entered

^d Study Root Information Model only

^e Date range also possible

^f Implicitly if no series search attributes have been entered

Attribute name	Tag	Type	Matching	User input	return value display
Number of Study related Instances	(0020,1208)	O	universal (Null)	-	no
Series Level					
Series Instance UID	(0020,000E)	U	single value	-	yes
Series Number	(0020,0011)	R	universal (Null)	-	yes
Modality	(0008,0060)	R	universal (Null)	enter value	yes
Series Date	(0008,0021)	O	universal (Null)	-	yes
Series Time	(0008,0031)	O	universal (Null)	-	yes
Series Description	(0008,103E)	O	universal (Null)	enter value	yes
Body Part Examined	(0018,0015)	O	universal (Null)	enter value	yes
Performing Physician	(0008,1050)	O	universal (Null)	enter value	yes
Storage Media File-Set ID	(0008,0130)	O	universal (Null)	-	yes
Retrieve AE Title	(0008,0054)	O	universal (Null)	-	yes
Protocol Name	(0018,1030)	O	universal (Null)	-	no
Perf. Procedure Step Start Date	(0040,0244)	O	universal (Null)	-	yes
Perf. Procedure Step Start Time	(0040,0245)	O	universal (Null)	-	yes
Requested Attribute Sequence	(0040,0275)	O	universal (Null)	-	yes
> Requested Procedure ID	(0040,1001)	O	universal (Null)	-	yes
> Scheduled Procedure ID	(0040,0009)	O	universal (Null)	-	yes
Number of Series related Instances	(0020,1209)	O	universal (Null)	-	yes
Image Level					
SOP Instance UID	(0008,0018)	U	single value	-	no
Image Number	(0020,0013)	R	universal (Null)	-	yes
Storage Media File-Set ID	(0008,0130)	O	universal (Null)	-	no
Retrieve AE Title	(0008,0054)	O	universal (Null)	-	no
Instance Date	(0008,0023)	O	universal (Null)	-	no
Instance Time	(0008,0033)	O	universal (Null)	-	no
Number of Frames	(0028,0008)	O	universal (Null)	-	yes
Image Comments	(0020,4000)	O	universal (Null)	-	no

The Find SCU interprets following status codes:

C-FIND response status

Service Status	Meaning	Protocol Codes	Related Fields
Refused	Out of Resources	A700	(0000,0902)
Failed	Identifier does not match SOP Class	A900	(0000,0901) (0000,0902)
	Unable to process	Cxxx	(0000,0901) (0000,0902)
Cancel	Matching terminated due to Cancel request	FE00	None
Success	Matching is complete - No final Identifier is supplied	0000	None
Pending	Matches are continuing - Current Match is supplied and any Optional Keys were supported in the same manner as Required Keys	FF00	Identifier
	Matches are continuing - Warning that one or more Optional Keys were not supported for existence and/or matching for this identifier	FF01	Identifier

9.1.2.1.3.1 Conformance Statement –e.soft Find SCU

The e.soft DICOM Query/Retrieve SCU supports hierarchical Study and Series level queries. The interactive querying of attributes on IMAGE level is not supported by the Query SCU, hence retrieval of individual Objects is possible. The search keys for the Study Level query model that the SCU supports

Attribute name	Tag	Type	Matching	User input	return value display
Study Level					
Patient Name ^a	(0010,0010)	R	Wildcard ^d	enter value	yes
Patient ID	(0010,0020)	R	Wildcard ^d	enter value	yes
Study Date	(0008,0020)	R	universal (Null)	enter value b	yes
Accession Number	(0008,0050)	R	universal (Null)	-	yes

9.1.2.2 Real-World Activity – Move SCU

9.1.2.2.1 Associated Real-World Activity – Move SCU “Import”

When selecting a data entry in the Query UI and activate the “Import” function, a retrieval request is passed to the archival application which issues a C-MOVE service according to the Patient Root or Study Root query model. (The Storage Service Class Conformance Statement describes the C-STORE service, which is generated by processing the C -MOVE service.)

The transferred image data are processed as described in the storage class SCP descriptions.

The possibility to request the remote C-MOVE provider (remote application that responded to the C-FIND) to move data to an application entity other than the C-MOVE SCU (the e.soft DICOM application) is NOT USED.

^a Wildcards inserted as a prefix and suffix, queries as “conatins”.

C-MOVE operation on Patient Level is not supported by the Query UI.

9.1.2.2.2 Proposed Presentation Contexts - Move SCU “Import”

The e.soft DICOM application will propose Presentation Contexts as shown in the following table:

Presentation Context Table					
Abstract Syntax		Transfer Syntax		Role	Ext. Neg.
Name	UID	Name List	UID List		
Patient Root Query/Retrieve Model – MOVE	1.2.840.10008.5.1.4.1.2.1.2	Implicit VR Little Endian Explicit VR Little Endian Explicit VR Big Endian	1.2.840.10008.1.2 1.2.840.10008.1.2.1 1.2.840.10008.1.2.2	SCU	None
Study Root Query/Retrieve Model – MOVE	1.2.840.10008.5.1.4.1.2.2.2	Implicit VR Little Endian Explicit VR Little Endian Explicit VR Big Endian	1.2.840.10008.1.2 1.2.840.10008.1.2.1 1.2.840.10008.1.2.2	SCU	None

Note: C-MOVE extended negotiation will not be supported by the SCU

9.1.2.2.3 SOP Specific Conformance Statement - Move SCU “Import”

At association establishment time the C-MOVE presentation context shall be negotiated. The C - STORE sub-operations must be done on a different association to transfer images to the own Storage Service Class SCP.

The Move SCU interprets following status codes:

Service Status	Meaning	Error Codes	Related Fields
Refused	Out of Resources - Unable to calculate number of matches	A701	(0000,0902)
	Out of Resources - Unable to perform sub operations	A702	(0000,1020) (0000,1021) (0000,1022) (0000,1023)
Failed	Identifier does not match SOP Class	A900	(0000,0901) (0000,0902)
	Unable to process	CXXX	(0000,0901) (0000,0902)
Cancel	Sub-operations terminated due to Cancel Indication	FE00	(0000,1020) (0000,1021) (0000,1022) (0000,1023)
Warning	Sub-operations Complete - One or more Failures or Warnings	B000	(0000,1020) (0000,1021) (0000,1022) (0000,1023)
Success	Sub-operations Complete - No Failures or Warning	0000	(0000,1020) (0000,1021) (0000,1022) (0000,1023)
Pending	Sub-operations are continuing	FF00	(0000,1020) (0000,1021) (0000,1022) (0000,1023)

9.1.3 Association Acceptance Policy

The e.soft DICOM application will accept associations for the following DIMSE-C operations as SCP:

- C-FIND

- C-GET
- C-MOVE
- C-FIND-CANCEL
- C-GET-CANCEL
- C-MOVE -CANCEL

9.1.3.1 Real-World Activity - Find SCP

9.1.3.1.1 Associated Real-World Activity - Find SCP

The associated Real-World activity is to respond query requests to an SCU with the query model Patient Root, Study Root and Patient/Study Only. Relational retrieve operation is NOT supported. With a C-FIND-CANCEL request the running query can be canceled at any time.

Multiple C-FIND requests over the same association are supported.

9.1.3.1.2 Accepted Presentation Contexts - Find SCP

The e.soft DICOM application will accept Presentation Contexts as shown in the following table:

Presentation Context Table					
Abstract Syntax		Transfer Syntax		Role	Ext. Neg.
Name	UID	Name List	UID List		
Patient Root Query/Retrieve Model – FIND	1.2.840.10008.5.1.4.1.2.1.1	Implicit VR Little Endian Explicit VR Little Endian Explicit VR Big Endian	1.2.840.10008.1.2 1.2.840.10008.1.2.1 1.2.840.10008.1.2.2	SCP	None
Study Root Query/Retrieve Model – FIND	1.2.840.10008.5.1.4.1.2.2.1	Implicit VR Little Endian Explicit VR Little Endian Explicit VR Big Endian	1.2.840.10008.1.2 1.2.840.10008.1.2.1 1.2.840.10008.1.2.2	SCP	None
Patient/Study Only Query/Retrieve Model – FIND	1.2.840.10008.5.1.4.1.2.3.1	Implicit VR Little Endian Explicit VR Little Endian Explicit VR Big Endian	1.2.840.10008.1.2 1.2.840.10008.1.2.1 1.2.840.10008.1.2.2	SCP	None

Note: C-FIND Extended Negotiation will NOT be supported.

The order of preference for accepting Transfer Syntaxes is: 1. Explicit VR Little Endian, 2. Explicit VR Big Endian, 3. Implicit VR Little Endian

9.1.3.1.3 SOP Specific Conformance Statement - Find SCP

The e.soft DICOM Query/Retrieve SCP supports hierarchical queries with all mandatory and optional search keys.

The query attribute contents will be treated case-sensitive.

With wildcard queries the symbol “?” is treated as “*” by the C-FIND SCP application. As a consequence the query string of “?abc*” will be processed as “*abc*”.

If the value for the patientlevel unique key “Patient ID” is not known, it may be returned with zero length. The attribute “Image Comments” will not be included in the C-FIND-RSP, if it is not set in the DB, even if it was requested as return key in the related C-FIND-RQ.

Usage of Storage Media File-Set ID, Retrieve AE Title with C-FIND-RSP message:

- The Storage Media File-Set ID - if existent - can be returned at Study/Series/Image Level. Only on Image Level, the values of ONLINE, NEARLINE or OFFLINE are returned to indicate the Storage Location of the related Instance.
- The Retrieve AE Title - if existent - can only be returned at Image Level (for Patient Root and Study Root models) or Study Level (for Patient/Study Only model).

Relational Queries are **not** supported.

A remote DICOM AE can cancel the running query by sending a C-FIND-CANCEL. Matches are possibly continuing (more C-FIND response with status PENDING) until the cancel operation has completed.

The supported attributes on the various query levels of the three supported information models are list in the tables of the following sections.

9.1.3.1.3.1 Patient Root Information Model

Attribute Name	Tag	Usage SCU	Matching
Patient Level			
Patient Name	(0010,0010)	R	single value, wildcard, universal
Patient ID	(0010,0020)	U	single value, wildcard, universal
Patient's Birth Date	(0010,0030)	O	single value, range, universal
Patient's Birth Time	(0010,0032)	O	single value, range, universal
Patient's Sex	(0010,0040)	O	single value, wildcard, universal
Ethnic Group	(0010,2160)	O	single value, wildcard, universal
Patient Comments	(0010,4000)	O	wildcard, universal
Number of Patient related Studies	(0020,1200)	O	universal
Number of Patient related Series	(0020,1202)	O	universal
Number of Patient related Instances	(0020,1204)	O	universal
Study Level			
Study Instance UID	(0020,000D)	U	single value, list of UIDs
Study ID	(0020,0010)	R	single value, wildcard, universal
Study Date	(0008,0020)	R	single value, range, universal
Study Time	(0008,0030)	R	single value, range, universal
Accession Number	(0008,0050)	R	single value, wildcard, universal
Referring Physician's Name	(0008,0090)	O	single value, wildcard, universal
Study Description	(0008,1030)	O	single value, wildcard, universal
Admitting Diagnoses Description	(0008,1080)	O	single value, wildcard, universal
Patient's Age	(0010,1010)	O	single value, wildcard, universal
Patient's Size	(0010,1020)	O	single value, universal
Patient's Weight	(0010,1030)	O	single value, universal
Occupation	(0010,2180)	O	single value, wildcard, universal
Additional Patient History	(0010,21B0)	O	wildcard, universal
Name of Physician reading Study	(0008,1060)	O	single value, wildcard, universal
Modalities in Study	(0008,0061)	O	multiple values, universal
Number of Study related Series	(0020,1206)	O	universal
Number of Study related Instances	(0020,1208)	O	universal
Series Level			
Series Instance UID	(0020,000E)	U	single value, list of UID
Series Number	(0020,0011)	R	single value, universal

Attribute Name	Tag	Usage SCU	Matching
Modality	(0008,0060)	R	single value, wildcard, universal
Laterality	(0020,0060)	O	single value, wildcard, universal
Body Part Examined	(0018,0015)	O	single value, wildcard, universal
Patient Position	(0018,5100)	O	single value, wildcard, universal
Smallest Pixel Value in Series	(0028,0108)	O	single value, universal
Largest Pixel Value in Series	(0028,0109)	O	single value, universal
Protocol Name	(0018,1030)	O	single value, wildcard, universal
Series Date	(0008,0021)	O	single value, range, universal
Series Time	(0008,0031)	O	single value, range, universal
Series Description	(0008,103E)	O	single value, wildcard, universal
Operators Name	(0008,1070)	O	single value, wildcard, universal
Performing Physician's Name	(0008,1050)	O	single value, wildcard, universal
Perf. Procedure Step Start Date	(0040,0244)	O	universal
Perf. Procedure Step Start Time	(0040,0245)	O	universal
Number of Series related Instances	(0020,1209)	O	universal
Imags Level			
SOP Instance UID	(0008,0018)	U	single value, list of UID
Image Number	(0020,0013)	R	single value, universal
Image Date	(0008,0023)	O	single value, range, universal
Image Time	(0008,0033)	O	single value, range, universal
Modality	(0008,0060)	O	single value, wildcard, universal
Image Comments	(0020,4000)	O	Universal

Supported Query attributes sorted by Query Level – Patient Root Information Model

9.1.3.1.3.2 Study Root Information Model

Attribute Name	Tag	Usage SCU	Matching
Study Level			
Patient Name	(0010,0010)	R	Single value, Wildcard, universal
Patient ID	(0010,0020)	R	Single Value, Wildcard, universal
Patient's Birth Date	(0010,0030)	O	Single Value, Range, universal
Patient's Birth Time	(0010,0032)	O	Single Value, Range, universal
Patient's Sex	(0010,0040)	O	Single Value, Wildcard, universal
Patient Comments	(0010,4000)	O	Wildcard, universal
Number of Patient related Studies	(0020,1200)	O	universal
Number of Patient related Series	(0020,1202)	O	universal
Number of Patient related Instances	(0020,1204)	O	universal
Study Instance UID	(0020,000D)	U	Single Value, List of UIDs
Study ID	(0020,0010)	R	Single Value, Wildcard, universal
Study Date	(0008,0020)	R	Single Value, Range, universal
Study Time	(0008,0030)	R	Single Value, Range, universal
Accession Number	(0008,0050)	R	Single Value, Wildcard, universal
Referring Physician's Name	(0008,0090)	O	Single Value, Wildcard, universal
Study Description	(0008,1030)	O	Single Value, Wildcard, universal
Admitting Diagnosis Description	(0008,1080)	O	Single Value, Wildcard, universal
Patient's Age	(0010,1010)	O	Single Value, Wildcard, universal
Patient's Size	(0010,1020)	O	Single Value, universal
Patient's Weight	(0010,1030)	O	Single Value, universal
Occupation	(0010,2180)	O	Single Value, Wildcard, universal
Additional Patient History	(0010,21B0)	O	Wildcard, universal

Attribute Name	Tag	Usage SCU	Matching
Name of Physician reading the Study	(0008,1060)	O	Single Value, Wildcard, universal
Modalities in Study	(0008,0061)	O	Multiple values, universal
Number of Study Related Series	(0020,1206)	O	universal
Number of Study Related Instances	(0020,1208)	O	universal
Series Level			
Series Instance UID	(0020,000E)	U	Single Value, List of UIDs
Series Number	(0020,0011)	R	Single Value, universal
Modality	(0008,0060)	R	Single Value, Wildcard, universal
Laterality	(0020,0060)	O	Single Value, Wildcard, universal
Body Part Examined	(0018,0015)	O	Single Value, Wildcard, universal
Patient Position	(0018,5100)	O	Single Value, Wildcard, universal
Smallest Pixel Value in Series	(0028,0108)	O	Single Value, universal
Largest Pixel Value in Series	(0028,0109)	O	Single Value, universal
Protocol Name	(0018,1030)	O	Single Value, Wildcard, universal
Series Date	(0008,0021)	O	Single Value, Range, universal
Series Time	(0008,0031)	O	Single Value, Range, universal
Series Description	(0008,103E)	O	Single Value, Wildcard, universal
Operator's Name	(0008,1070)	O	Single Value, Wildcard, universal
Performing Physician's Name	(0008,1050)	O	Single Value, Wildcard, universal
Performed Procedure Step Start Date	(0040,0244)	O	universal
Performed Procedure Step Start Time	(0040,0245)	O	universal
Number of Series related Instances	(0020,1209)	O	universal
Image Level			
SOP Instance UID	(0008,0018)	U	Single Value, List of UIDs
Image Number	(0020,0013)	R	Single Value, universal
Image Date	(0008,0023)	O	Single Value, Range, universal
Image Time	(0008,0033)	O	Single Value, Range, universal
Modality	(0008,0060)	O	Single Value, Wildcard, universal
Image Comments	(0020,4000)	O	universal

Supported Query attributes sorted by Query Level – Study Root Information Model

9.1.3.1.3.3 Patient/Study Only Information Model

Attribute Name	Tag	Usage SCU	Matching
Patient Level			
Patient Name	(0010,0010)	R	Single value, Wildcard, universal
Patient ID	(0010,0020)	U	Single Value, Wildcard, universal
Patient's Birth Date	(0010,0030)	O	Single Value, Range, universal
Patient's Birth Time	(0010,0032)	O	Single Value, Range, universal
Patient's Sex	(0010,0040)	O	Single Value, Wildcard, universal
Ethnic Group	(0010,2160)	O	Single Value, Wildcard, universal
Patient Comments	(0010,4000)	O	Wildcard, universal
Number of Patient related Studies	(0020,1200)	O	universal
Number of Patient related Series	(0020,1202)	O	universal
Number of Patient related Instances	(0020,1204)	O	universal
Study Level			
Study Instance UID	(0020,000D)	U	Single Value, List of UIDs
Study ID	(0020,0010)	R	Single Value, Wildcard, universal
Study Date	(0008,0020)	R	Single Value, Range, universal
Study Time	(0008,0030)	R	Single Value, Range, universal
Accession Number	(0008,0050)	R	Single Value, Wildcard, universal
Referring Physician's Name	(0008,0090)	O	Single Value, Wildcard, universal
Study Description	(0008,1030)	O	Single Value, Wildcard, universal
Admitting Diagnosis Description	(0008,1080)	O	Single Value, Wildcard, universal

Attribute Name	Tag	Usage SCU	Matching
Patient's Age	(0010,1010)	O	Single Value, Wildcard, universal
Patient's Size	(0010,1020)	O	Single Value, universal
Patient's Weight	(0010,1030)	O	Single Value, universal
Occupation	(0010,2180)	O	Single Value, Wildcard, universal
Additional Patient History	(0010,21B0)	O	Wildcard, universal
Name of Physician reading the Study	(0008,1060)	O	Single Value, Wildcard, universal
Modalities in Study	(0008,0061)	O	Multiple values, universal
Number of Study Related Series	(0020,1206)	O	universal
Number of Study Related Instances	(0020,1208)	O	universal

Supported Query attributes sorted by Query Level – Patient/Study Only Information Model

The Find SCP returns following status codes:

Service Status	Meaning	Error Codes	Related Fields
Refused	Out of Resources	A700	(0000,0902)
Failed	Identifier does not match SOP Class	A900	(0000,0901) (0000,0902)
	Unable to process	C001	(0000,0901) (0000,0902)
Cancel	Matching terminated due to Cancel request	FE00	None
Success	Matching is complete - No final Identifier is supplied	0000	None
Pending	Matches are continuing - Current Match is supplied and any Optional Keys were supported in the same manner as Required Keys	FF00	Identifier
	Matches are continuing - Warning that one or more Optional Keys were not supported for existence and/or matching for this identifier	FF01	Identifier

9.1.3.2 Real-World Activity - Get SCP

9.1.3.2.1 Associated Real-World Activity - Get SCP

The associated Real-World activity is to respond to retrieve requests initiated from a foreign SCU. The SCP supports the query model Patient Root, Study Root and Patient/Study Only. The Storage Service Class Conformance Statement describes the C-STORE service, which is generated by the C-GET service. Relational retrieve operation is NOT supported.

Multiple C-GET requests over the same association are NOT supported.

9.1.3.2.2 Accepted Presentation Contexts - Get SCP

The e.soft DICOM application will accept Presentation Contexts as shown in the following table:

Presentation Context Table					
Abstract Syntax		Transfer Syntax		Role	Ext. Neg.
Name	UID	Name List	UID List		
Patient Root Query/Retrieve Model – GET	1.2.840.10008.5.1.4.1.2.1.3	Implicit VR Little Endian Explicit VR Little Endian Explicit VR Big Endian	1.2.840.10008.1.2 1.2.840.10008.1.2.1 1.2.840.10008.1.2.2	SCP	None
Study Root Query/Retrieve Model – GET	1.2.840.10008.5.1.4.1.2.2.3	Implicit VR Little Endian Explicit VR Little Endian Explicit VR Big Endian	1.2.840.10008.1.2 1.2.840.10008.1.2.1 1.2.840.10008.1.2.2	SCP	None

Patient/Study Only Query/Retrieve Model – GET	1.2.840.10008.5.1.4.1.2.3.3	Implicit VR Little Endian Explicit VR Little Endian Explicit VR Big Endian	1.2.840.10008.1.2 1.2.840.10008.1.2.1 1.2.840.10008.1.2.2	SCP	None
---	-----------------------------	--	---	-----	------

Note: C-GET Extended negotiation will NOT be supported.

The order of preference for accepting Transfer Syntaxes is: 1. Explicit VR Little Endian, 2. Explicit VR Big Endian, 3. Implicit VR Little Endian.

9.1.3.2.3 SOP Specific Conformance Statement - Get SCP

At association establishment time the C-GET presentation context must be negotiated along with the C-STORE sub-operations which must be accomplished on the same association as the C-GET operation. Relational retrieve operation is NOT supported.

All unique keys have to be supplied according to the selected Query/Retrieve Level. The related tables in the C-FIND SCP section will give information about “U” marked key attributes.

The Get SCP returns following status codes:

Service Status	Meaning	Error Codes	Related Fields
Refused	Out of Resources - Unable to calculate number of matches	A701	(0000,0902)
	Out of Resources - Unable to perform sub operations	A702	(0000,1020) (0000,1021) (0000,1022) (0000,1023)
Failed	Identifier does not match SOP Class	A900	(0000,0901) (0000,0902)
	Unable to process	C001	(0000,0901) (0000,0902)
Cancel	Sub-operations terminated due to Cancel Indication	FE00	(0000,1020) (0000,1021) (0000,1022) (0000,1023)
Warning	Sub-operations Complete - One or more Failures of Warnings	B000	(0000,1020) (0000,1021) (0000,1022) (0000,1023)
Success	Sub-operations Complete - No Failures or Warning	0000	(0000,1020) (0000,1021) (0000,1022) (0000,1023)
Pending	Sub-operations are continuing	FF00	(0000,1020) (0000,1021) (0000,1022) (0000,1023)

9.1.3.3 Real-World Activity - Move SCP

9.1.3.3.1 Associated Real-World Activity - Move SCP

The associated Real-World activity is to respond to retrieve requests to an SCU. The SCP supports the query model Patient Root, Study Root and Patient/Study Only. The Storage Service Class Conformance Statement describes the C-STORE service, which is generated by the C-MOVE service. Relational retrieve operation is NOT supported.

Multiple C-MOVE requests over the same association are NOT supported.

9.1.3.3.2 Accepted Presentation Contexts - Move SCP

The e.soft DICOM application will accept Presentation Contexts as shown in the following table:

Presentation Context Table

Abstract Syntax		Transfer Syntax		Role	Ext. Neg.
Name	UID	Name List	UID List		
Patient Root Query/Retrieve Model – MOVE	1.2.840.10008.5.1.4.1.2.1.2	Implicit VR Little Endian Explicit VR Little Endian Explicit VR Big Endian	1.2.840.10008.1.2 1.2.840.10008.1.2.1 1.2.840.10008.1.2.2	SCP	None
Study Root Query/Retrieve Model – MOVE	1.2.840.10008.5.1.4.1.2.2.2	Implicit VR Little Endian Explicit VR Little Endian Explicit VR Big Endian	1.2.840.10008.1.2 1.2.840.10008.1.2.1 1.2.840.10008.1.2.2	SCP	None
Patient/Study Only Query/Retrieve Model – MOVE	1.2.840.10008.5.1.4.1.2.3.2	Implicit VR Little Endian Explicit VR Little Endian Explicit VR Big Endian	1.2.840.10008.1.2 1.2.840.10008.1.2.1 1.2.840.10008.1.2.2	SCP	None

Note: C-MOVE Extended negotiation will NOT be supported.

The order of preference for accepting Transfer Syntaxes is: 1. Explicit VR Little Endian, 2. Explicit VR Big Endian, 3. Implicit VR Little Endian.

9.1.3.3.3 SOP Specific Conformance Statement - Move SCP

At association establishment time the C-MOVE presentation context shall be negotiated. The C - STORE sub-operations is done on a different association, specified in the C-MOVE request, to transfer images to a remote SCP of the Storage Service Class. Relational retrieve operation is NOT supported.

All unique keys have to be supplied according to the selected Query/Retrieve Level. The related tables in the C -FIND SCP section will give information about “U” marked key attributes.

The Move SCP returns following status codes:

Service Status	Meaning	Error Codes	Related Fields
Refused	Out of Resources - Unable to calculate number of matches	A701	(0000,0902)
	Out of Resources - Unable to perform sub operations	A702	(0000,1020) (0000,1021) (0000,1022) (0000,1023)
Failed	Identifier does not match SOP Class	A900	(0000,0901) (0000,0902)
	Unable to process	C001	(0000,0901) (0000,0902)
Cancel	Sub-operations terminated due to Cancel Indication	FE00	(0000,1020) (0000,1021) (0000,1022) (0000,1023)
Warning	Sub-operations Complete - One or more Failures of Warnings	B000	(0000,1020) (0000,1021) (0000,1022) (0000,1023)
Success	Sub-operations Complete - No Failures or Warning	0000	(0000,1020) (0000,1021) (0000,1022) (0000,1023)
Pending	Sub-operations are continuing	FF00	(0000,1020) (0000,1021) (0000,1022) (0000,1023)

10 Implementation Model Print

The Print Management Service Classes define an application-level class of services, which facilitate the printing of images on a hardcopy medium. The print management SCU and print management SCP are peer DICOM print management application entities. The *syngo* DICOM print application supports the print management DIMSE services to act as SCU.

10.1 Application Data Flow Diagram

The *syngo* DICOM network implementation acts as SCU for the print management network service. The product target Operating System is Microsoft Windows XP Professional

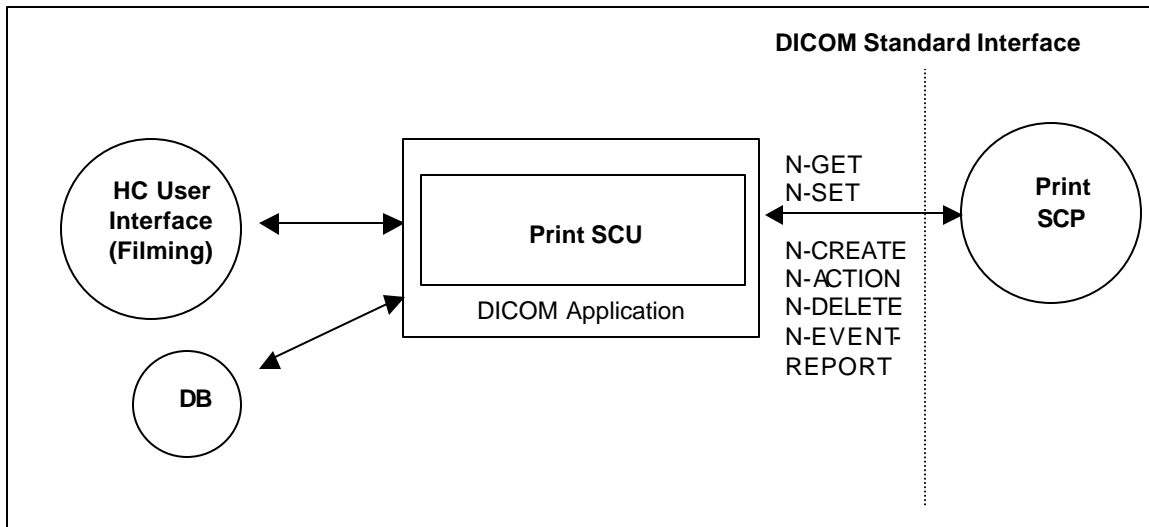

Figure 6: DICOM Application Data Flow Diagram – Print SCU

10.2 Functional Definition of Application Entities

The Print SCU is invoked by the user interface to setup film-sheet layout and whenever an image is ready to be printed on film. The Print SCU will hold and maintain all data needed to compile a complete film-sheet from the data (images, layout, configuration) received. Whenever a film-sheet is ready to print the related data is used to supply the Information to the SOP Classes of the Print Management Service Class. A queue is maintained, in order to intermediately store several film-sheets in case of resource problems on printer. The SCU will only supply and require the mandatory SOP Classes of the Print Management Service Class.

10.3 Sequencing of Real-World Activities

Not applicable

11 Application Entity Specification Print

11.1 Print Management AE Specification

The *syngo* print management SCU (HCS) invokes print management DIMSE services to transfer images from the local AE to the remote SCP AE to print images with defined layout on a selected network-based DICOM hardcopy printer. This is done in an “full-page” print mode.

e.soft provides Standard Conformance to the following DICOM V3.0 Print Management Meta SOP Classes as an SCU:

SOP Class Name	SOP Class UID
Basic Grayscale Print Management Meta SOP Class	1.2.840.10008.5.1.1.9
- Basic Film Session SOP Class	1.2.840.10008.5.1.1.1
- Basic Film Box SOP Class	1.2.840.10008.5.1.1.2
- Basic Grayscale Image Box SOP Class	1.2.840.10008.5.1.1.4
- Printer SOP Class	1.2.840.10008.5.1.1.16
Print Job SOP Class	1.2.840.10008.5.1.1.14
Presentation LUT SOP Class	1.2.840.10008.5.1.1.23

SOP Class Name	SOP Class UID
Basic Color Print Management Meta SOP Class	1.2.840.10008.5.1.1.18
- Basic Film Session SOP Class	1.2.840.10008.5.1.1.1
- Basic Film Box SOP Class	1.2.840.10008.5.1.1.2
- Basic Color Image Box SOP Class	1.2.840.10008.5.1.1.4.1
- Printer SOP Class	1.2.840.10008.5.1.1.16
Print Job SOP Class	1.2.840.10008.5.1.1.14

11.1.1 Association Establishment Policies

11.1.1.1 General

Whenever a film is completely set up and printed by command or automatism, the job is prepared for processing. As soon as the queue is ready to process the job is activated and worked according the processing data. The related Print application will initiate an association to the print destination and process the printing of the related information. The default PDU size used will be 28 KB.

11.1.1.2 Number of Associations

The *syngo* DICOM Print application initiates one association at a time for each different print device configured.

11.1.1.3 Asynchronous Nature

The *syngo* DICOM software does not support asynchronous communication (multiple outstanding transactions over a single association).

11.1.1.4 Implementation Identifying Information

Implementation Class UID	1.2.12.2.1107.5.9.20000101
Implementation Version Name	SIEMENS_SWFVD20K

11.1.2 Association Initiation Policy

Triggered by the Print job queue the Print Management SCU establishes an association by using the DICOM association services. With the help of the N-GET request for the Printer SOP Class the Status is determined before printing.

With no problem encountered with the N-CREATE/N-SET Services for the related Basic Print SOP Classes the film sheet is set up for printing and the image(s) is(are) transferred to the printer device.

After the last film is printed from queue, the Print application will leave open the association for another 60 seconds. If a new film job is ready for printing within this timelimit, the job will be immediately processed over the still open association. If there is no new job, the association is closed if the time-out elapsed. This is done to optimize automated printing.

During the "idle-time" (no open association to printer) the Print application will issue a cyclic camera status request (using N-GET of Printer SOP Class) every 5 minutes.

11.1.2.1 Associated Real-World Activity

11.1.2.1.1 Associated Real-World Activity – Printing a Printer Job Queue Entry

Whenever a film-sheet is prepared by the user, it is forwarded to the Printer Job queue. As soon as the associated Printer device is available the job is activated and association is set up.

The film sheet is internally processed, converted to a Standard/1-1 page and then the page image is sent. Status is controlled by awaiting any N-EVENT message all through the transfer until the last image or film-sheet is sent.

If the response from the remote application contains a status other than Success or Warning the association is aborted.

11.1.2.1.2 Proposed Presentation Context (Presentation Context Table)

The Siemens *syngo* DICOM Print application will propose Presentation Contexts as shown in the following table:

Presentation Context Table					
Abstract Syntax		Transfer Syntax		Role	Ext. Neg.
Name	UID	Name List	UID List		
Basic Grayscale Print Management Meta SOP class	1.2.840.10008.5.1.1.9	Implicit VR Little Endian Explicit VR Little Endian Explicit VR Big Endian	1.2.840.10008.1.2 1.2.840.10008.1.2.1 1.2.840.10008.1.2.2	SCU	None
Basic Color Print Management Meta SOP class	1.2.840.10008.5.1.1.18	Implicit VR Little Endian Explicit VR Little Endian Explicit VR Big Endian	1.2.840.10008.1.2 1.2.840.10008.1.2.1 1.2.840.10008.1.2.2	SCU	None
Basic film session SOP class	1.2.840.10008.5.1.1.1	Implicit VR Little Endian Explicit VR Little Endian Explicit VR Big Endian	1.2.840.10008.1.2 1.2.840.10008.1.2.1 1.2.840.10008.1.2.2	SCU	None
Basic Film Box SOP class	1.2.840.10008.5.1.1.2	Implicit VR Little Endian Explicit VR Little Endian Explicit VR Big Endian	1.2.840.10008.1.2 1.2.840.10008.1.2.1 1.2.840.10008.1.2.2	SCU	None
Basic Grayscale Image Box SOP class	1.2.840.10008.5.1.1.4	Implicit VR Little Endian Explicit VR Little Endian Explicit VR Big Endian	1.2.840.10008.1.2 1.2.840.10008.1.2.1 1.2.840.10008.1.2.2	SCU	None
Basic Color Image Box SOP class	1.2.840.10008.5.1.1.4.1	Implicit VR Little Endian Explicit VR Little Endian Explicit VR Big Endian	1.2.840.10008.1.2 1.2.840.10008.1.2.1 1.2.840.10008.1.2.2	SCU	None
Printer SOP class	1.2.840.10008.5.1.1.16	Implicit VR Little Endian Explicit VR Little Endian Explicit VR Big Endian	1.2.840.10008.1.2 1.2.840.10008.1.2.1 1.2.840.10008.1.2.2	SCU	None
Print Job SOP class	1.2.840.10008.5.1.1.14	Implicit VR Little Endian Explicit VR Little Endian Explicit VR Big Endian	1.2.840.10008.1.2 1.2.840.10008.1.2.1 1.2.840.10008.1.2.2	SCU	None
Presentation LUT SOP class	1.2.840.10008.5.1.1.23	Implicit VR Little Endian Explicit VR Little Endian Explicit VR Big Endian	1.2.840.10008.1.2 1.2.840.10008.1.2.1 1.2.840.10008.1.2.2	SCU	None

11.1.2.1.3 SOP specific Conformance Statement – Meta SOP Classes

The *syngo* DICOM print management SCU conforms to the DICOM Basic Grayscale Print Management Meta SOP Class and the Basic Color Print Management Meta SOP Class.

The application uses a setting platform to define the properties of the connected DICOM SCP, e.g.:

- maximum number of print jobs in the queue
- maximum number of print copies
- supported film sizes of the connected DICOM SCP
- supported film formats of the DICOM SCP
- lookup table definition.

The printing is only suspended in the case of a failure return status of the SCP.

11.1.2.1.3.1 Basic Film Session SOP class

The Basic Film Session information object definition describes all the user-defined parameters, which are common for all the films of a film session. The Basic Film Session refers to one or more Basic Film Boxes and that are printed on one hardcopy printer.

The *syngo* DICOM print management SCU supports the following DIMSE Service elements for the Basic Film Session SOP Class as SCU:

- N-CREATE, N -DELETE

The Basic Film Session SOP Class N-CREATE -RQ (SCU) uses the following attributes:

Attribute Name	Tag	Usage SCU	Supported Values
Number of Copies	(2000,0010)	U	1
Medium Type	(2000,0030)	U	BLUE FILM CLEAR FILM PAPER
Film Destination	(2000,0040)	U	MAGAZINE PROCESSOR

The number of Copies sent to the DICOM Printer is always 1, the job is sent n times for n copies.

The affected SOP Instance UID received with N-CREATE -RSP message will be kept internally and used for later requests (e.g. N-DELETE -RQ) on the Basic Film Session – see below:

Attribute Name	Tag	Source of Information
Requested SOP Instance UID	(0000,1000) → (0000,1001)	Affected SOP Instance UID of NCREATE-RSP on Basic Film Session

The N-DELETE-RQ on the Basic Film Session SOP Class is used to remove the complete Basic Film Session SOP Instance hierarchy.

The Basic Film Session SOP class interprets the following status codes (from N-CREATE -RSP, N-DELETE -RSP messages):

Service Status	Meaning	Error Codes
Failed	Film session SOP instances hierarchy does not contain film box SOP instances	C600
	Unable to create print job, print queue is full	C601
	Image size is larger than images box size	C603
Warning	Memory allocation not supported	B600
	Film session printing is not supported	B601
Success	Film box does not contain image box (empty page)	B602
	Film belonging to the film session are accepted for printing	0000

11.1.2.1.3.2 Basic Film Box SOP class

The Basic Film Box information object definition describes all the user-defined parameter of one film of the film session . The Basic Film Box information description defines the presentation parameters, which are common for all images on a given sheet of film.

The Basic Film Box refers to one or more Image Boxes.

Supported Service Elements as SCU are:

- N-CREATE
- N-ACTION
- N-DELETE

The Basic Film Box SOP class N-CREATE-RQ message uses the following attributes (the actual values for each attribute depend on DICOM printer configuration within the *syngo* DICOM print management SCU):

Attribute Name	Tag	Usage SCU	Supported Values
Image Display Format	(2010,0010)	M	STANDARD1,1
Referenced Film Session Sequence	(2010,0500)	M	
> Referenced SOP Class UID	(0008,1150)	M	1.2.840.10008.5.1.1.1
> Referenced SOP Instance UID	(0008,1155)	M	
Film Orientation	(2010,0040)	M	PORTRAIT
Film Size ID	(2010,0050)	M	8INX10IN, 10INX12IN, 10INX14IN, 11INX14IN,, 14INX14IN, 14INX17IN, 24CMX24CM, 24CMX30CM
Magnification Type	(2010,0060)	M	BILINEAR, CUBIC, NONE, REPLICATE
Border Density	(2010,0100)	U	BLACK, WHITE
Max Density	(2010,0130)	U	0 < Value
Min Density	(2010,0120)	U	0 < Value < 50
Illumination	(2010,015E)	U	0 < Value Required if Presentation LUT is present.
Reflective Ambient Light	(2010,0160)	U	0 < Value Required if Presentation LUT is present.
Referenced Presentation LUT Sequence	(2050,0500)	U	

The N-CREATE-RSP message from the Print SCP includes the Referenced Image Box Sequence with SOP Class/Instance UID pairs which will be kept internally to be further used for the subsequent Basic Image Box SOP Class N-SET-RQ messages.

When all Image Boxes (including parameters) for the film-sheet have been set, the *syngo* DICOM print manager will issue a N-ACTION-RQ message with the SOP Instance UID of the Basic Film Box and the Action Type ID of 1.

The affected SOP Instance UID received with N-CREATE -RSP message will be kept internally and used for later requests (e.g. N-DELETE -RQ) on the Basic Film Box - see below:

Attribute Name	Tag	Source of Information
Requested SOP Instance UID	(0000,1000) → (0000,1001)	Affected SOP Instance UID of N-CREATE-RSP on Basic Film Box

The Basic Film Box SOP class interprets the following status codes:

Service Status	Meaning	Error Codes
Failure	Unable to create print job, print queue is full	C602
	Image size is larger than images box size	C603
Warning	Film box does not contain image box (empty page)	B603
	Requested MinDensity or MaxDensity outside of Printer's operating range	B605
Success	Film accepted for printing	0000

11.1.2.1.3.3 Basic Grayscale Image Box SOP Class

The Basic Grayscale Image Box informationobject definition is the presentation of an image and image related data in the image area of a film. The Basic Image Box information describes the presentation parameters and image pixel data, which apply to a single image of a sheet of film.

The Grayscale Image Box SOP Class uses only the N-SET-RQ with the following attributes:

Attribute Name	Tag	Usage SCU	Supported Values
Image Position	(2020,0010)	M	1

Attribute Name	Tag	Usage SCU	Supported Values
BASIC Grayscale Image Sequence	(2020,0110)	M	
> Samples per Pixel	(0028,0002)	M	1
> Photometric Interpretation	(0028,0004)	M	MONOCHROME2
> Rows	(0028,0010)	M	
> Columns	(0028,0011)	M	
> Pixel Aspect Ratio	(0028,0034)	M	
> Bits Allocated	(0028,0100)	M	8
> Bits Stored	(0028,0101)	M	8
> High Bit	(0028,0102)	M	7
> Pixel Representation	(0028,0103)	M	0
> Pixel Data	(7FE0,0010)	M	

The Grayscale Image Box SOP class interpret the following status codes:

Service Status	Meaning	Error Codes
Failure	Image contains more pixel than printer can print in Image Box	C603
	Insufficient memory in printer to store the image	C605
Warning	Requested MinDensity or MaxDensity outside of Printer's operating range	B605
Success		0000

11.1.2.1.3.4 Basic Color Image Box SOP Class

The Basic Color Image Box information object definition is the presentation of an image and image related data in the image area of a film. The Basic Image Box information describes the presentation parameters and image pixel data, which apply to a single image of a sheet of film.

The Color Image Box SOP Class uses only the N-SET-RQ with the following attributes:

Attribute Name	Tag	Usage SCU	Supported Values
Image Position	(2020,0010)	M	1
BASIC Color Image Sequence	(2020,0111)	M	
> Samples per Pixel	(0028,0002)	M	3
> Photometric Interpretation	(0028,0004)	M	RGB
> Planar Configuration	(0028,0006)	M	0
> Rows	(0028,0010)	M	
> Columns	(0028,0011)	M	
> Pixel Aspect Ratio	(0028,0034)	M	
> Bits Allocated	(0028,0100)	M	8
> Bits Stored	(0028,0101)	M	8
> High Bit	(0028,0102)	M	7
> Pixel Representation	(0028,0103)	M	0
> Pixel Data	(7FE0,0010)	M	

The Color Image Box SOP class interpret the following status codes:

Service Status	Meaning	Error Codes
Failure	Image contains more pixel than printer can print in Image Box	C603
	Insufficient memory in printer to store the image	C605
Warning	Image size larger than image box size	B604
Success		0000

11.1.2.1.3.5 Presentation LUT SOP Class

The objective of the Presentation LUT is to realize image hardcopy printing tailored for specific modalities, applications and user preferences.

The output of the Presentation LUT is Presentation Values (P-Values). P-Values are approximately related to human perceptual response. They are intended to facilitate common input for hardcopy. P-Values are intended to be independent of the specific class or characteristics of the hardcopy device.

The Presentation LUT SOP Class uses only the N-CREATE -RQ with the following attributes:

Attribute Name	Tag	Usage SCU	Supported Values
Presentation LUT Shape	(2050,0020)	U	IDENTITY

The affected SOP Instance UID received with N-CREATE -RSP message will be kept internally and is used for later requests on the Basic Film Box (N-CREATE -RQ) and on the Presentation LUT (N-DELETE -RQ) - see below:

Attribute Name	Tag	Source of Information
Requested SOP Instance UID	(0000,1000) → (0000,1001)	Affected SOP Instance UID of NCREATE-RSP on Presentation LUT

The Presentation LUT SOP class interprets the following status codes:

Service Status	Meaning	Error Codes
Warning	Requested MinDensity or MaxDensity outside of HCD's operating range. HCD will use its respective minimum or maximum density value instead.	B605
Success	Presentation LUT successfully created	0000

11.1.2.1.3.6 Printer SOP Class

The Printer SOP Class is the possibility to monitor the status of the hardcopy printer in a synchronous and an asynchronous way.

The SCU uses the mandatory N-EVENT Report DIMSE service to monitor the changes of the printer status in an asynchronous way.

It can directly ask the Printer (SCP) for its status or receive Events from the Printer asynchronously:

- N-GET as SCU

N-EVENTREPORT as SCU In both cases the following information is supported:

Used Printer N -EVENT Report attributes

Event-type Name	Event	Attributes	Tag	Usage SCU
Normal	1			
Warning	2	Printer Status Info	(2110,0020)	U
Failure	3	Printer Status Info	(2110,0020)	U

11.1.2.1.3.6.1.1 Mandatory Printer N-GET-RSP, N-EVENT-REPORT-RQ attributes

Attribute Name	Tag	Usage SCP	Supported Values
----------------	-----	-----------	------------------

Printer Status	(2110,0010)	M	NORMAL, FAILURE, WARNING
Printer Status Info	(2110,0020)	M	See tables in Annex for details.

Note: For a detailed description on how *syngo* reacts on different printer status messages, please refer to the Annex section "DICOM Print SCU – detailed status displays".

11.1.2.1.3.7 Print Job SOP Class

The Print Job SOP Class is the possibility to monitor the execution of the print process.

The *syngo* DICOM Print Management application supports the optional N-EVENT-REPORT DICMSE Service to receive the changes of the Print Job Status in an asynchronous way.

It can receive Events from the Print SCP asynchronously

Note: *syngo* does not support receiving N-EVENT from camera during print sessions, normally this is configurable in the camera.

N-EVENTREPORT The following information is supported:

Used Print Job N-EVENT Report attributes

Event-type Name	Event	Attributes	Tag	Usage SCU
Normal	1	Execution Status Info	(2100,0030)	U
		Print Job ID	(2100,0010)	-- (Print Queue Management SOP Class not supported)
		Film Session Label	(2000,0050)	U
		Printer Name	(2110,0030)	U
Printing	2	Execution Status Info	(2100,0030)	U
		Print Job ID	(2100,0010)	-- (Print Queue Management SOP Class not supported)
		Film Session Label	(2000,0050)	U
		Printer Name	(2110,0030)	U
Done	3	Execution Status Info	(2100,0030)	U
		Print Job ID	(2100,0010)	-- (Print Queue Management SOP Class not supported)
		Film Session Label	(2000,0050)	U
		Printer Name	(2110,0030)	U
Failure	4	Execution Status Info	(2100,0030)	U
		Print Job ID	(2100,0010)	-- (Print Queue Management SOP Class not supported)
		Film Session Label	(2000,0050)	U
		Printer Name	(2110,0030)	U

Note: For a detailed description on how *syngo* reacts on different printer status messages, please refer to the Annex section "DICOM Print SCU – detailed status displays".

11.1.3 Association Acceptance Policy

Not applicable

12 Implementation Model Worklist

DICOM Modality Worklist is supported on e.cam based acquisition systems.

DICOM Modality Worklist is available for ECAT, but limited to only supporting the Patient Name, Patient ID and Accession Number (limited to a maximum of 12 characters) attributes, no other worklist attributes are supported.

The Basic Worklist Management Service class defines an application-level class of service, which facilitates the transfer of worklists from the information system to the imaging modality. The worklist is queried by the AE and supplies the SCU with the scheduled tasks, which have to be performed on the modality. The e.soft DICOM worklist application supports the worklist service as SCU.

12.1 Application Data Flow Diagram

The e.soft DICOM network implementation acts as SCU for the Basic Worklist Service using the Modality Worklist SOP Class. The product target Operating System is Microsoft Windows XP Professional.

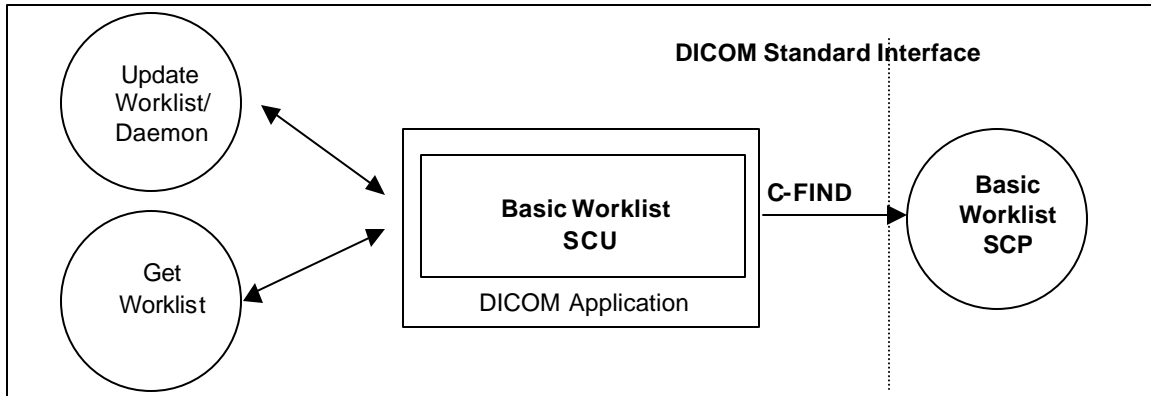

Figure 7: e.soft Application Flow Diagram – Basic Worklist SCU

12.2 Functional Definitions of Application Entities

The worklist SCU ("broad query") is invoked from the patient browser user interface or by timer to request the worklist from a remote Information System (Modality Worklist Class SCP). This is done to perform a match to the internal worklist query keys specified in the C-Find DIMSE service issued for the Modality Worklist Model.

The worklist SCP responds to the C-FIND query and scheduled imaging service requests (scheduled procedure steps) and patient demographic information will be downloaded from the information system to the e.soft modality. All information retrieved will be hold in the scheduling database for usage during Patient registration procedure.

Furthermore the patient based Query dialog from the patient browser allows to enter specific matching criteria ("narrow query") for the issue worklist query. With the response data the Patient Registration dialog can be populated according availability within the worklist response identifier.

12.3 Sequencing of Real-World Activities

The “narrow” (interactive) Worklist Query requires that sufficient matching keys or a unique matching key are/is entered before the query is issued. Only then a single response can be expected to complete the registration dialog.

13 Application Entity Specification Worklist

13.1 Modality Worklist Service AE Specification

The Modality worklist SCU (patient registration in conjunction with the network application) requests that the remote SCP performs a match of all keys specified in the query against the information in its worklist database.

The e.soft DICOM network implementation acts as SCU for the Basic Worklist Service using the Modality Worklist SOP Class:

SOP Class Name	SOP Class UID
Modality Worklist Information Model - FIND	1.2.840.10008.5.1.4.31

13.1.1 Association Establishment Policies

13.1.1.1 General

It is possible to configure a cyclic update of the modality scheduler database through a background worklist request with date/time and modality information.

In addition the user can request worklist update with "Update Worklist". No duplicate entries will be added in the Scheduler DB. Entries are uniquely identified by the Study Instance UID (0020,000D) for the Requested Procedure and the SPS ID (0040,009) in the SPS Sequence (0040,0100).

An interactive worklist query can be issued with search criteria entered in the patient based Query dialog from the patient browser.

The default PDU size used will be 28 KB.

13.1.1.2 Number of Associations

The e.soft DICOM application initiates one association at a time to query worklist entry data.

13.1.1.3 Asynchronous Nature

The e.soft DICOM software does not support asynchronous communication (multiple outstanding transactions over a single association).

13.1.1.4 Implementation Identifying Information

Implementation Class UID	1.3.12.2.1107.5.9.20000101
Implementation Version Name	SIEMENS_SWFVD20K

13.1.2 Association Initiation Policy

The network application will cyclically query the worklist and by request of patient registration interface. Ever then it establishes an association by using the DICOM association services. During association establishment the negotiation of SOP classes to exchange the capabilities of the SCU and the SCP is not supported.

The following DIMSE-C operation is supported as SCU:

- C-FIND

13.1.2.1 Real-World Activity

13.1.2.1.1 Associated Real-World Activity - Query (Update) Worklist

A network application will perform worklist queries with the C -FIND request at regular intervals. In addition it can be triggered by immediate request. The received worklist items will be compared with the contents of the local scheduler database. New items will be inserted into scheduler database.

After each broad-query, all RP/SPS that were canceled or rescheduled to another modality at the RIS will be automatically removed from the Scheduler DB if :

1. the Examination of this procedure has not been started or finished yet, and
2. the corresponding configuration item "Automatic removal of canceled/rescheduled Request" was checked in the Service UI under DICOM/His-Ris Node.

No automatic clean-up of the scheduler DB is performed after a Patient base Query since the worklist received does not give the complete list of all currently scheduled procedures for the modality.

13.1.2.1.2 Proposed Presentation Contexts

The e.soft DICOM application will propose Presentation Contexts as shown in the following table:

Presentation Context Table					
Abstract Syntax		Transfer Syntax		Role	Ext. Neg.
Name	UID	Name List	UID List		
Modality Worklist Information Model - FIND	1.2.840.10008.5.1.4.31	Implicit VR Little Endian Explicit VR Little Endian Explicit VR Big Endian	1.2.840.10008.1.2 1.2.840.10008.1.2.1 1.2.840.10008.1.2.2	SCU	None

13.1.2.1.3 SOP Specific Conformance Statement

- Search Key Attributes of the Worklist C -FIND

The e.soft DICOM worklist SCU supports "broad worklist queries" with all required search keys. The following tables describe the "broad query" search keys that the SCU supports.

Attribute Name	Tag	Matching Key Type	Query Value
Scheduled Procedure Step			

Attribute Name	Tag	Matching Key Type	Query Value
Scheduled Procedure Step Sequence	(0040,0100)	R	
>Scheduled Station AE Title	(0040,0001)	R	<own AET> or "*" ^a
>Scheduled Procedure Step Start Date	(0040,0002)	R	<act. Date>-<act. Date> or range from UI ^b
>Scheduled Procedure Step Start Time	(0040,0003)	R	<zero length> or range from UI ^b
>Modality	(0008,0060)	R	"*" or <own Modality> ^a

- Return Key Attributes of the Worklist C -FIND

The e.soft DICOM worklist SCU supports worklist queries with return key attributes of all types. The following tables describe the return keys that the SCU supports.

An "x" in the **UI** column will indicate the attribute is visualized when browsing the Worklist results with Patient Browser and/or during Patient Registration. The Patient Browser display is additionally influenced by the related Browser configuration.

An "x" in the **IOD** column will indicate that the related attribute is included into the SOP Instances of the IOD's created during processing of this worklist request (e.soft e.cam based systems only).

A tag in the **MPPS** column will indicate that the related attribute is included into the SOP Instances of the MPPS objects created during processing of this worklist request. (See also the tables "Attributes used for the Performed Procedure Step N-CREATE" and "Attributes used for the Performed Procedure Step N -SET".)

Attribute Name	Tag	Return Key Type	UI	IOD	MPPS
SOP Common					
Specific Character Set	(0008,0005)	1C	-	(0008,0005)	(0008,0005)
Scheduled Procedure Step					
Scheduled Procedure Step Sequence	(0040,0100)	1			
>Modality	(0008,0060)	1	x	(0008,0060)	(0008,0060)
>Requested Contrast Agent	(0032,1070)	2C	x	(0032,1070)	
>Scheduled Station AE Title	(0040,0001)	1	x		(0040,0241) ^c
>Scheduled Procedure Step Start Date	(0040,0002)	1	x		
>Scheduled Procedure Step Start Time	(0040,0003)	1	x		
>Scheduled Procedure Step End Date	(0040,0004)	3	-		
>Scheduled Procedure Step End Time	(0040,0005)	3	-		
>Scheduled Performing Physician's Name	(0040,0006)	1	x	(0008,1050) ^d	(0008,1050) ^d
>Scheduled Procedure Step Description	(0040,0007)	1C	x	(0040,0007) (0040,0254) ^e	(0040,0007) (0040,0254) ^e
>Scheduled Protocol Code Sequence ^f	(0040,0008)	1C	-	(0040,0008) (0040,0260) ^g	(0040,0008) (0040,0260) ^g
>>Code Value	(0008,0100)	1C	x		

^aThis depends on user configuration (Options ->Configuration->Patient Registration) if the "own AET" is provided or not. Use the "HIS/RIS" tabcard for configuration.

^bIt depends on user configuration (Options ->Configuration->Patient Registration) if the actual Date with a full time range or an interactive input dialog for date/time specification is used.

^c"Scheduled Station AE Title" is taken as default for "Performed Station AE Title"

^d"Scheduled Performing Physician's Name" is taken as default for "Performing Physician's Name"

^e"Scheduled Procedure Step Description" is taken as default for "Performed Procedure Step Description"

^fUses universal sequence match

^g"Scheduled Protocol Code Sequence" is taken as default for "Performed Protocol Code Sequence"

Attribute Name	Tag	Return Key Type	UI	IOD	MPPS
>>Coding Scheme Designator	(0008,0102)	1C	x		
>>Coding Scheme Version	(0008,0103)	3	x		
>>Code Meaning	(0008,0104)	3	x		
>Scheduled Procedure Step ID	(0040,0009)	1	x	(0040,0009) (0040,0253) ^a	(0040,0009) (0040,0253) ^a
>Scheduled Station Name	(0040,0010)	2	x		
>Scheduled Procedure Step Location	(0040,0011)	2	x		(0040,0242) ^b
>Pre-Medication	(0040,0012)	2C	x		
>Scheduled Procedure Step Status	(0040,0020)	3	x		
>Comments on the Scheduled Procedure Step	(0040,0400)	3	-		
Requested Procedure					
Referenced Study Sequence ^c	(0008,1110)	2	-	(0008,1110)	(0008,1110)
>Referenced SOP Class UID	(0008,1150)	1C	-		
>Referenced SOP Instance UID	(0008,1155)	1C	-		
Study Instance UID	(0020,000D)	1	-	(0020,000D)	(0020,000D)
Requested Procedure Description	(0032,1060)	1C	x	(0032,1060)	(0032,1060)
Requested Procedure Code Sequence ^c	(0032,1064)	1C	-	(0008,1032) ^d (0032,1064)	(0008,1032) ^d
>Code Value	(0008,0100)	1C	x		
>Coding Scheme Designator	(0008,0102)	1C	x		
>Coding Scheme Version	(0008,0103)	3	x		
>Code Meaning	(0008,0104)	3	x		
Requested Procedure ID	(0040,1001)	1	x	(0040,1001) (0020,0010) ^e	(0040,1001) (0020,0010) ^e
Reason for the Requested Procedure	(0040,1002)	3	-		
Requested Procedure Priority	(0040,1003)	2	x		
Patient Transport Arrangements	(0040,1004)	2	-		
Requested Procedure Location	(0040,1005)	3	-		
Confidentiality Code	(0040,1008)	3	-		
Reporting Priority	(0040,1009)	3	-		
Names of intended Recipients of Results	(0040,1010)	3	-	(0008,1048)	
Requested Procedure Comments	(0040,1400)	3	x		
Imaging Service Request					
Accession Number	(0008,0050)	2	x	(0008,0050)	(0008,0050)
Referring Physician's Name	(0008,0090)	2	x	(0008,0090)	
Requesting Physician	(0032,1032)	2	x	(0032,1032)	(0032,1032)
Requesting Service	(0032,1033)	3	x	(0032,1033)	
Reason for the Imaging Service Request	(0040,2001)	3	-		
Issuing Date of Imaging Service Request	(0040,2004)	3	-		
Issuing Time of Imaging Service Request	(0040,2005)	3	-		
Placer Order Number / Imaging Service Request ^f	(0040,2016)	3	-		(0040,2016)
Filler Order Number / Imaging Service Request ^g	(0040,2017)	3	-		(0040,2017)
Order entered by ...	(0040,2008)	3	-		
Order Enterer's location	(0040,2009)	3	-		
Order Callback Phone Number	(0040,2010)	3	-		
Imaging Service Request Comments	(0040,2400)	3	x		
Visit Identification					

^a“Scheduled Procedure Step ID” is taken as default for “Performed Procedure Step ID”

^b“Scheduled Procedure Step Location” is taken as default for “Performed Location”

^cUses universal sequence match

^d“Requested Procedure Code Sequence” is taken as default for “Procedure Code Sequence”

^e“Requested Procedure ID” is taken as default for “Study ID”

^fOld tag (0040,2006) is retired and not used.

^gOld tag (0040,2007) is retired and not used.

Attribute Name	Tag	Return Key Type	UI	IOD	MPPS
Institution Name	(0008,0080)	3	x	(0008,0080)	
Institution Address	(0008,0081)	3	-	(0008,0081)	
Institution Code Sequence ^a	(0008,0082)	3	-		
>Code Value	(0008,0100)	1C	-		
>Coding Scheme Designator	(0008,0102)	1C	-		
>Coding Scheme Version	(0008,0103)	3	-		
>Code Meaning	(0008,0104)	3	-		
Admission ID	(0038,0010)	2	x		
Issuer of Admission ID	(0038,0011)	3	-		
Visit Status					
Visit Status ID	(0038,0008)	3	-		
Current Patient Location	(0038,0300)	2	x		
Patient's Institution Residence	(0038,0400)	3	-		
Visit Comments	(0038,4000)	3	-		
Visit Relationship					
Referenced Study Sequence ^a	(0008,1110)	3	-		
>Referenced SOP Class UID	(0008,1150)	1C	-		
>Referenced SOP Instance UID	(0008,1155)	1C	-		
Referenced Patient Sequence ^a	(0008,1120)	2	-		(0008,1120)
>Referenced SOP Class UID	(0008,1150)	1C	-		
>Referenced SOP Instance UID	(0008,1155)	1C	-		
Visit Admission					
Referring Physician's Name	(0008,0090)	2	x	(0008,0090)	
Referring Physician's Address	(0008,0092)	3	-		
Referring Physician's Phone Numbers	(0008,0094)	3	-		
Admitting Diagnosis Description	(0008,1080)	3	x	(0008,1080)	
Admitting DiagnosisCode Sequence ^a	(0008,1084)	3	-		
>Code Value	(0008,0100)	1C	-		
>Coding Scheme Designator	(0008,0102)	1C	-		
>Coding Scheme Version	(0008,0103)	3	-		
>Code Meaning	(0008,0104)	3	-		
Route of Admissions	(0038,0016)	3	-		
Admitting Date	(0038,0020)	3	-		
Admitting Time	(0038,0021)	3	-		
Patient Identification					
Patient's Name	(0010,0010)	1	x	(0010,0010)	(0010,0010)
Patient ID	(0010,0020)	1	x	(0010,0020)	(0010,0020)
Issuer of Patient ID	(0010,0021)	3	-	(0010,0021)	
Other Patient IDs	(0010,1000)	3	x	(0010,1000)	
Other Patient Names	(0010,1001)	3	x	(0010,1001)	
Patient's Birth Name	(0010,1005)	3	-	(0010,1005)	
Patient's Mother's Birth Name	(0010,1060)	3	-	(0010,1060)	
Medical Record Locator	(0010,1090)	3	-	(0010,1090)	
Patient Demographic					
Patient's Birth Date	(0010,0030)	2	x	(0010,0030)	(0010,0030)
Patient's Birth Time	(0010,0032)	3	-	(0010,0032)	
Patient's Sex	(0010,0040)	2	x	(0010,0040)	(0010,0040)
Patient's Insurance Plan Code Sequence ^a	(0010,0050)	3	-	(0010,0050)	
>Code Value	(0008,0100)	1C	-		
>Coding Scheme Designator	(0008,0102)	1C	-		
>Coding Scheme Version	(0008,0103)	3	-		

^aUses universal sequence match

Attribute Name	Tag	Return Key Type	UI	IOD	MPPS
>Code Meaning	(0008,0104)	3	-		
Patient's Age	(0010,1010)	3	x	(0010,1010)	
Patient's Size	(0010,1020)	3	x	(0010,1020)	
Patient's Weight	(0010,1030)	2	x	(0010,1030)	
Patient's Address	(0010,1040)	3	x	(0010,1040)	
Military Rank	(0010,1080)	3	x	(0010,1080)	
Branch of Service	(0010,1081)	3	-	(0010,1081)	
Country of Residence	(0010,2150)	3	-	(0010,2150)	
Region of Residence	(0010,2152)	3	-	(0010,2152)	
Patient's Telephone Numbers	(0010,2154)	3	-	(0010,2154)	
Ethnic Group	(0010,2160)	3	x	(0010,2160)	
Occupation	(0010,2180)	3	-	(0010,2180)	
Patient's Religious Preference	(0010,21F0)	3	-	(0010,21F0)	
Patient Comments	(0010,4000)	3	x	(0010,4000)	
Patient Data Confidentiality Constraint Description	(0040,3001)	2	x	(0040,3001)	
Patient Medical					
Medical Alerts	(0010,2000)	2	x	(0010,2000)	
Contrast Allergies	(0010,2110)	2	x	(0010,2110)	
Pregnancy Status	(0010,21C0)	2	x	(0010,21C0)	
Smoking Status	(0010,21A0)	3	x	(0010,21A0)	
Last Menstrual Date	(0010,21D0)	3	x	(0010,21D0)	
Additional Patient History	(0010,21B0)	3	x	(0010,21B0)	
Special Needs	(0038,0050)	2	x	(0038,0050)	
Patient State	(0038,0500)	2	x	(0038,0500)	
Patient Relationship					
Referenced Study Sequence ^a	(0008,1110)	3	-		
>Referenced SOP Class UID	(0008,1150)	1C	-		
>Referenced SOP Instance UID	(0008,1155)	1C	-		
Referenced Visit Sequence ^a	(0008,1125)	3	-		
>Referenced SOP Class UID	(0008,1150)	1C	-		
>Referenced SOP Instance UID	(0008,1155)	1C	-		
Referenced Patient Alias Sequence ^a	(0038,0004)	3	-		
>Referenced SOP Class UID	(0008,1150)	1C	-		
>Referenced SOP Instance UID	(0008,1155)	1C	-		

13.1.2.1.4 Associated Real-World Activity – Get Worklist

With "Get Worklist" in the patient based Worklist Query dialog, the entered attributes are used to form a worklist request identifier. With the response data the Patient Registration dialog can be updated to perform examination in advance. The response data are additionally placed in the scheduler database

13.1.2.1.5 Proposed Presentation Contexts – Get Worklist

This RWA will propose the same Presentation Contexts as with "Update Worklist". Please see table in section 13.1.2.1.2.

^aUses universal sequence match

13.1.2.1.6 SOP Specific Conformance – Get Worklist

13.1.2.1.6.1.1.1.1 Search Key Attributes of the Worklist C-FIND

The e.soft DICOM worklist SCU supports “narrow worklist queries” with all required search keys. The following tables describe the “narrow query” search keys that the SCU supports.

Attribute Name	Tag	Matching Key Type	Query Value
Scheduled Procedure Step			
Scheduled Procedure Step Sequence	(0040,0100)	R	
>Scheduled Performing Physician's Name	(0040,0006)	R	input from UI or <zero length>
Requested Procedure			
Requested Procedure ID	(0040,1001)	O	input from UI or <zero length>
Imaging Service Request			
Accession Number	(0008,0050)	O	input from UI or <zero length>
Referring Physician's Name	(0008,0090)	O	input from UI or <zero length>
Visit Status			
Current Patient Location	(0038,0300)	O	input from UI or <zero length>
Patient Identification			
Patient's Name	(0010,0010)	R	input from UI or <zero length>
Patient ID	(0010,0020)	R	input from UI or <zero length>

13.1.2.1.6.1.1.1.2 Return Key Attributes of the Worklist C-FIND

Please see list for “Update Worklist” RWA.

13.1.2.1.6.1.1.1.3 Status Codes of the Worklist C-FIND

The worklist SCU interprets following status codes:

Service Status	Meaning	Error Codes	Related Fields
Refused	Out of Resources	A700	(0000,0902)
Failed	Identifier does not match SOP Class	A900	(0000,0901) (0000,0902)
	Unable to process	Cxxx	(0000,0901) (0000,0902)
Cancel	Matching terminated due to Cancel request	FE00	None
Success	Matching is complete - No final Identifier is supplied	0000	None
Pending	Matches are continuing - Current Match is supplied and any Optional Keys were supported in the same manner as Required Keys	FF00	Identifier
	Matches are continuing - Warning that one or more Optional Keys were not supported for existence and/or matching for this identifier	FF01	Identifier

14 Implementation Model MPPS

The Modality Performed Procedure Step Service class defines an application-level class of service which facilitates the transfer of procedure and billing information from the imaging modality to the information system. The Performed Procedure Step is created and set by the AE and supplies the SCP with the information about a real-world procedure which is performed on the modality. The e.soft DICOM Modality Performed Procedure Step application supports the MPPS service as SCU.

14.1 Application Data Flow Diagram

The e.soft DICOM network implementation acts as SCU for the Modality Performed Procedure Step SOP Class. The product target Operating System is Microsoft Windows XP Professional.

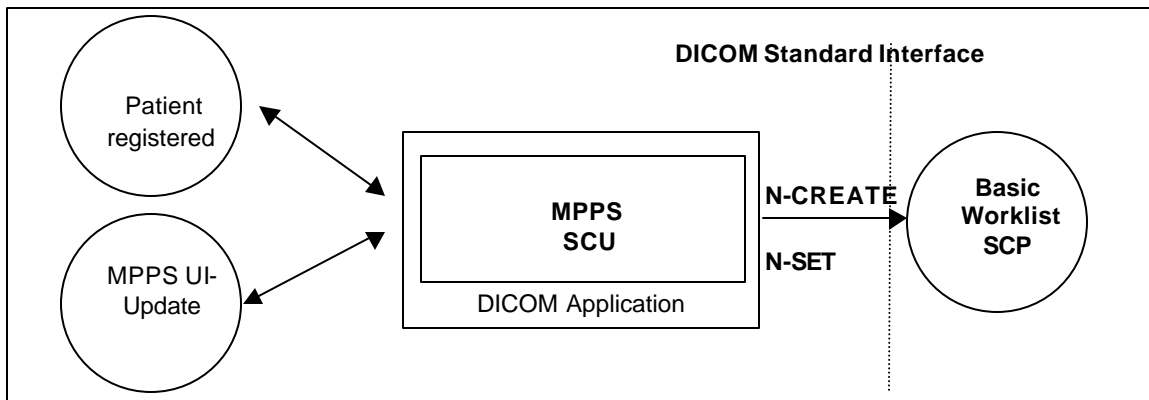

Figure 8: e.soft Application Flow Diagram – MPPS SCU

14.2 Functional Definitions of Application Entities

With registering a Patient (i.e. a Scheduled Procedure Step from Worklist), the e.soft DICOM application will create a MPPS Instance and communicate it to the MPPS SCP.

Furthermore a manual update can be performed with the e.soft syngo MPPS user interface or an automated update is possible within an e.soft workflow. Using the syngo MPPS user interface it is possible to set the state of the MPPS to “Completed” or “Discontinued” If done so, the syngo MPPS application will no longer allow updates on the related MPPS Instance. Within an e.soft workflow it is possible to update the MPPS state to “Completed”.

The e.soft will not only allow a "1:1 -relationship" of Scheduled Procedure Steps and Performed Procedure Steps, but also supports the "simple group-case" (grouping several SPS of the same Requested Procedure) , "complex group-case" (grouping several SPS from different Requested Procedures) and "append case" from the respective IHE-scenarios.

The e.soft will support creation of “unscheduled cases” by allowing MPPS Instances to be communicated for locally registered Patients.

15 AE Specification MPPS

15.1 Modality Performed Procedure Step AE Specification

The Modality Performed Procedure Step SCU (Patient Registration and MPPS UI) provide information about a performed real-world Procedure to a remote SCP (Information System).

e.soft provides Standard Conformance to the following DICOM V3.0 SOP Class as an SCU:

SOP Class Name	SOP Class UID
Modality Performed Procedure Step	1.2.840.10008.3.1.2.3.3

15.1.1.1 General

The creation of MPPS Instance is done automatically by e.soft whenever a patient is registered for image acquisition through the Patient Registration dialog.

Further updates on the MPPS data can be done from the related syngo MPPS user interface or from the completion of an e.soft workflow.

The default PDU size used will be 256 KB.

15.1.1.2 Number of Associations

The e.soft DICOM application initiates one association at a time to create or set MPPS instance.

15.1.1.3 Asynchronous Nature

The e.soft DICOM software does not support asynchronous communication (multiple outstanding transactions over a single association).

15.1.1.4 Implementation Identifying Information

Implementation Class UID	<modify 1.3.12.2.1107.5.9.20010101>
Implementation Version Name	SIEMENS_SWFVD20K

15.1.2 Association Initiation Policy

The e.soft DICOM Application Entity acts as a Service Class User (SCU) for the

- Modality Performed Procedure Step Service Class (to notify a RIS about status of a procedure while it is performed).
To do so, the e.soft will issue a
- N-CREATE DIMSE according to the CREATE Modality Performed Procedure Step SOP Instance operation or a

- N-SET DIMSE to update the contents and state of the MPPS according to the SET Modality Performed Procedure Step Information operation.

15.1.2.1 Real World Activity

15.1.2.1.1 Associated Real-World Activity - Patient registered

A patient is registered by the Patient Registration “Exam” action. From this event the trigger to create a MPPS Instance is derived. The related Instance is then immediately communicated to the configured RIS system. An association is established and the MPPS Instance is sent.

15.1.2.1.2 Proposed Presentation Contexts - Patient registered

The e.soft DICOM application will propose Presentation Contexts as shown in the following table:

Presentation Context Table					
Abstract Syntax		Transfer Syntax		Role	Ext. Neg.
Name	UID	Name List	UID List		
Modality Performed Procedure Step	1.2.840.10008.3.1.2.3.3	Implicit VR Little Endian Explicit VR Little Endian Explicit VR Big Endian	1.2.840.10008.1.2 1.2.840.10008.1.2.1 1.2.840.10008.1.2.2	SCU	None

15.1.2.1.3 SOP Specific Conformance Statement- Patient registered

15.1.2.1.3.1.1.1 Attributes used for the Performed Procedure Step N-CREATE

The e.soft DICOM Modality Performed Procedure Step SCU informs the remote SCP when the examination of a scheduled procedure step will be performed (i.e. the patient is registered). The N-CREATE message is sent when the examination is started with a successful registration of the patient data. The following table describes the supported attributes of a N-CREATE message.

Attribute Name	Tag	Type	Value
SOP Common			
Specific Character Set	(0008,0005)	1C	from MWL or created
Performed Procedure Step Relationship			
Scheduled Step Attribute Sequence	(0040,0270)	1	
>Study Instance UID	(0020,000D)	1	from MWL or created
>Referenced Study Sequence	(0008,1110)	2	from MWL or <zero length>
>>Referenced SOP Class UID	(0008,1150)	1C	
>>Referenced SOP Instance UID	(0008,1155)	1C	
>Accession Number	(0008,0050)	2	from MWL or user input
>Placer Order Number/Imaging Service Request	(0040,2016)	3	from MWL or <zero length>
>Filler Order Number/Imaging Service Request	(0040,2017)	3	from MWL or <zero length>
>Requested Procedure ID	(0040,0001)	2	from MWL or user input
>Requested Procedure Description	(0032,1060)	2	from MWL or <zero length>
>Scheduled Procedure Step ID	(0040,0009)	2	from MWL or <zero length>
>Scheduled Procedure Step Description	(0040,0007)	2	from MWL or <zero length>
>Scheduled Action Item Sequence	(0040,0008)	2	from MWL or <zero length>
>>Code Value	(0008,0100)	1C	
>>Coding Scheme Designator	(0008,0102)	1C	
>>Coding Scheme Version	(0008,0103)	3	
>>Code Meaning	(0008,0104)	3	

Patient's Name	(0010,0010)	2	from MWL or user input
Patient ID	(0010,0020)	2	from MWL or user input
Patient's Birth Date	(0010,0030)	2	from MWL or user input
Patient's Sex	(0010,0040)	2	from MWL or user input
Referenced Patient Sequence	(0008,1120)	2	from MWL or <zero length>
>Referenced SOP Class UID	(0008,1150)	1C	
>Referenced SOP Instance UID	(0008,1155)	1C	
Performed Procedure Step Information			
Performed Procedure Step ID	(0040,0253)	1	From SPS ID or created
Performed Station AE Title	(0040,0241)	1	own AE Title
Performed Station Name	(0040,0242)	2	own hostname
Performed Location	(0040,0243)	2	from SPS location or <zero length>
Performed Procedure Step Start Date	(0040,0244)	1	created
Performed Procedure Step Start Time	(0040,0245)	1	created
Performed Procedure Step Status	(0040,0252)	1	"IN PROGRESS"
Performed Procedure Step Description	(0040,0254)	2	from SPS Description or <zero length>
Performed Procedure Type Description	(0040,0255)	2	<zero length>
Procedure Code Sequence	(0008,1032)	2	from Requested Procedure Code or <zero length>
>Code Value	(0008,0100)	1C	
>Coding Scheme Designator	(0008,0102)	1C	
>Coding Scheme Version	(0008,0103)	3	
>Code Meaning	(0008,0104)	3	
Performed Procedure Step End Date	(0040,0250)	2	<zero length>
Performed Procedure Step End Time	(0040,0251)	2	<zero length>
Image Acquisition Results			
Modality	(0008,0060)	1	NM
Study ID	(0020,0010)	2	from Requested Procedure ID or created
Performed Protocol Code Sequence	(0040,0260)	2	from Scheduled Action Item Sequence or <zero length>
>Code Value	(0008,0100)	1C	
>Coding Scheme Designator	(0008,0102)	1C	
>Coding Scheme Version	(0008,0103)	3	
>Code Meaning	(0008,0104)	3	
Performed Series Sequence	(0040,0340)	2	
>Performing Physician's Name	(0008,1050)	2C	from MWL or user input
>Operator's Name	(0008,1070)	2C	User input
>Series Instance UID	(0020,000E)	1C	created
>Series Description	(0008,103E)	2C	<zero length>
>Retrieve AE Title	(0008,0054)	2C	<zero length>
>Protocol Name	(0018,1030)	N/a	Userdefined description of the conditions under which the Series was performed.
>Referenced Image Sequence	(0008,1140)	2C	<zero length>
>Referenced Standalone SOP Instance Sequence	(0040,0220)	2C	<zero length>

15.1.2.1.3.1.1.1.2 Status Codes of the Performed Procedure Step N-CREATE

The Performed Procedure Step SCU interprets following status codes:

Service Status	Meaning	Error Codes (0000.0900)
Failure	Processing Failure	0110
	No such attribute	0105
	Invalid attribute value	0106
	Duplicate SOP Instance	0111

	No such SOP Instance	0112
	No such SOP Class	0118
	Class Instance conflict	0119
	Missing attribute	0120
	Missing attribute value	0121
	Resource limitation	0213
Success	MPPS Instance created	0000

15.1.2.1.4 Associated Real-World Activity – MPPS UI-Update

With the MPPS UI the status of the MPPS Instance can be set to “COMPLETED” or “DISCONTINUED”. There is no cyclic update during performance of the procedure.

15.1.2.1.5 Proposed Presentation Contexts – MPPS UI-Update

This RWA will propose the same Presentation Contexts as with “Patient registered”. Please see table in section 15.1.2.1.2.

15.1.2.1.6 SOP Specific Conformance Statement – MPPS UI-Update

15.1.2.1.6.1.1.1.1 Attributes used for the Performed Procedure Step N-SET

The e.soft DICOM Modality Performed Procedure Step SCU informs the remote SCP about the performed examination and its status. The N-SET message is sent only per ended examination (finished status “COMPLETED” or incomplete status “DISCONTINUED”). The following table describes the supported attributes of a N -SET message.

Attribute Name	Tag	Type	Value
Performed Procedure Step Information			
Performed Procedure Step Status	(0040,0252)	3	“COMPLETED” or “DISCONTINUED”
Performed Procedure Step Description	(0040,0254)	3	from SPS Description or user input
Performed Procedure Type Description	(0040,0255)	3	User input
Procedure Code Sequence	(0008,1032)	3	from Requested Procedure Code
>Code Value	(0008,0100)	1C	
>Coding Scheme Designator	(0008,0102)	1C	
>Coding Scheme Version	(0008,0103)	3	
>Code Meaning	(0008,0104)	3	
Performed Procedure Step End Date	(0040,0250)	1	created
Performed Procedure Step End Time	(0040,0251)	1	created
Image Acquisition Results			
Performed Protocol Code Sequence	(0040,0260)	3	from Scheduled Action Item Sequence
>Code Value	(0008,0100)	1C	
>Coding Scheme Designator	(0008,0102)	1C	
>Coding Scheme Version	(0008,0103)	3	
>Code Meaning	(0008,0104)	3	
Performed Series Sequence	(0040,0340)	1	
>Performing Physician's Name	(0008,1050)	2C	from MWL or user input
>Protocol Name	(0018,1030)	1C	from related SOP Instance
>Operator's Name	(0008,1070)	2C	user input
>Series Instance UID	(0020,000E)	1C	from related SOP Instance
>Series Description	(0008,103E)	2C	from related SOP Instance
>Retrieve AE Title	(0008,0054)	2C	from Storage Commitment response or <zero length>

>Referenced Image Sequence	(0008,1140)	2C	<zero length>
>>Referenced SOP Class UID	(0008,1150)	1C	
>>Referenced SOP Instance UID	(0008,1155)	1C	
>Referenced Standalone SOP Instance Sequence	(0040,0220)	2C	<zero length>
All other attributes from Billing and Material Code Module		3	From e.soft Activities

15.1.2.1.6.1.1.1.2 Status Codes of the Performed Procedure Step N-SET

The Performed Procedure Step SCU interprets following status codes:

Service Status	Meaning	Error Codes (0000.0900)
Failure	Processing Failure: Performed Procedure Step Object may no longer be updated.	0110
	No such attribute	0105
	Invalid attribute value	0106
	No such SOP Instance	0112
	Invalid Object instance	0117
	No such SOP Class	0118
	Class Instance conflict	0119
	Missing attribute value	0121
	Resource limitation	0213
Success	MPPS Instance set	0000

16 Communication Profiles

16.1 Supported Communication Stacks

The e.soft DICOM application provides DICOM V3.0 TCP/IP Network Communication Support as defined in Part 8 of the DICOM Standard.

The product target Operating System is Microsoft Windows XP Professional.

16.1.1 TCP/IP Stack

The e.soft DICOM application uses the TCP/IP stack from the target operating system upon which it executes. It uses the MergeCOM-3 subroutine library from Merge Technologies Inc. that is based on a Berkeley socket interface.

16.1.1.1 API

The e.soft DICOM application uses the MergeCOM library that is based on a TCP/IP socket interface.

16.1.1.2 Physical Media Support

The e.soft DICOM application is indifferent to the physical medium over which TCP/IP executes; it inherits this from the target operating system upon which it executes.

17 Extensions / Specializations / Privatizations

17.1.1 Standard Extended / Specialized / Private SOPs

Please refer to Annex for further information on these topics. A detailed overview is given the re.

17.1.2 Private Transfer Syntaxes

Not applicable

18 Configuration

18.1 AE Title/Presentation Address Mapping

To ensure unique identification within the network the hostname should be used as part of the AE Titles (see examples below, hostname = name1). The string can be up to 16 characters long and must not contain any extended characters, only 7-bit ASCII characters (excluding Control Characters) are allowed according to DICOM Standard.

Note: the current implementation of syngo does not support the full DICOM Standard. Spaces and special characters (like &<> ") in the AE title string are not supported.

18.1.1 DICOM Verification

The Verification Service uses the AE configuration of the DICOM Service that is checked with the C-ECHO message. e.g. Verification will use the Storage AE, if initiated to check the configuration of a remote DICOM node.

18.1.2 DICOM Storage AE Title

Within syngo there are local application entity titles for HIS/RIS, Study Transfer and Print. They can be configured via Service-UI in Configuration / DICOM / General (e.g. STU_NAME1).

The port number is set to the fixed value of 104.

18.1.2.1 DICOMReader Application

The e.soft DICOM application includes an additional Storage SCP for receiving NM images from non-e.soft workstations. For additional information contact your service representative. The DICOMReader supports the NM Image Storage SOP class. Using the Service application, the DICOMReader application can be configured to support any of the following transfer syntaxes. They are:

- Implicit_Little_Endian, or
- Explicit_Little_Endian, or
- Explicit_Big_Endian.

NM data received by the DICOMReader may have specific attributes modified. Therefore, it is not expected that the data will be transferred back to the originating application.

The DICOMReader AET and port number can be configured using the Service application. By default, the DICOMReader Storage SCP is set to listen on port 50082.

18.1.3 DICOM Query/Retrieve AE Title

The DICOM Query/Retrieve application uses the same application entity title as the DICOM Storage AE.

18.1.4 DICOM Print AE Title

The DICOM Print application provides the application entity title:

e.g. PRI_NAME1 *(No input of AETs starting with a numeric character is possible)*

18.2 Configurable Parameters

The Application Entity Titles, host names and port numbers for remote AE are configured using the e.soft Service/Installation Tool. For each AET the list of services supported can be configured.

18.2.1 Storage, Storage Commitment and Query/Retrieve

The e.soft Service/Installation Tool can be used to set the AET's, port-numbers, host-names, IP-addresses and capabilities for the remote nodes (SCP's). The user can select transfer syntaxes, compression modes and query models for each SCP separately.

- a quality factor which determines the proposed transfer syntax in case that an user has initiated the C-STORE. By convention, 0 means: Only Uncompressed Transfer Syntax(es) are proposed, 100 means: Lossless Transfer Syntax is proposed, and any other value between 1 and 99 means that an JPEG Lossy Transfer Syntax is proposed. One Uncompressed Transfer Syntax will be proposed in any case. This parameter is general for all destination nodes.
- a "compression type supported" which determines the proposed transfer syntax in case that the C-STORE was initiated as a sub-operation of an incoming C-MOVE-RQ. By convention, 0 means: Only Uncompressed Transfer Syntax(es) are proposed, 1 means: Lossless Transfer Syntax is proposed, and 2 means that an JPEG Lossy Transfer Syntax is proposed. One uncompressed transfer syntax will be proposed in any case. This parameter can be set for each configured destination node.

Additional configurable parameters for Storage Commitment are:

When acting as SCU:

- flag to indicate whether the association will be kept open to receive the response or to close the association and be prepared to receive the response on another association.
- time-out which defines how long the association of N-ACTION is kept to receive a N-EVENT-REPORT on the same association. The same value is used to wait for a N-EVENT-REPORT on an other association. (default 1 h)

When acting as SCP:

- flag to indicate if an archive system is installed

18.2.2 Print

The e.soft Service/Installation Tool can be used to configure the SCP (DICOM-Printer).

These parameters are mandatory to set:

- AET,

- host-name,
- IP-address and
- Port-number.

These parameters have defaults as per configuration file and can be changed:

- default camera (yes/no),
- pixel size,
- additional or changed film sheet formats (e.g. inch 14x14, inch 14x17, ...),
- list with mapping pixel size to each film sheet format,
- minimal density,
- stored printed film jobs,
- media type,
- film destination.

18.2.3 Modality Worklist

The Service application can be used to set the AETs, port numbers, host names, IP addresses, capabilities and time-outs for the remote nodes (SCPs)

Additional configurable parameters for Modality Worklist Query are:

- Query Waiting time - the time to wait for the C-FIND-RSP after sending the C-FIND-RQ (default 20 sec.)
- Max Query Match Number - the maximum number of entries accepted in one worklist (default is 200)
- Query Interval: the time between two C-FIND-RQ to the Hospital Information system (default is 60 min.)
- Broad Worklist Query behaviour (two values are defined):
 - Set the AE Title search attribute to the own AE Title, and the Modality search attribute to `""`.
 - Set the Modality search attribute to the own modality and the AE Title search attribute to `""`.

18.3 Default Parameters

This installation tool also uses some default parameters:

-
- time-out for accepting/rejecting an association request: 60 s
- time-out for responding to an association open/close request: 60 s
- time-out for accepting a message over network: 60 s
- time-out for waiting for data between TCP/IP-packets: 60 s

The time-outs for waiting for a Service Request/Response message from the remote node are as follows:

Media Storage Conformance Statement

This chapter will contain the Conformance Statement to all “Offline Media Application Profiles (incl. private extensions)” supported by the e.soft archive options.

Those application profiles supported shall be:

- Standard Application Profiles
- Augmented Application Profiles
- *syngo* private Application Profile

1 Introduction

1.1 Purpose

This DICOM Conformance Statement is written according to part PS 3.2 of [1].

The e.soft applications described in this conformance statement are based on *syngo*^a software. The e.soft DICOM offline media storage service implementation acts as FSC, FSU and/or FSR for the specified application profiles and the related SOP Class instances.

1.2 Scope

This DICOM Conformance Statement refers to e.soft based products using e.soft software. The following table relates e.soft software names to products:

Software Name	SIEMENS <i>syngo</i> -based Product
e.soft 3.5	e.soft

1.3 Definitions, Abbreviations

1.3.1 Definitions

DICOM	Digital Imaging and Communications in Medicine
DIMSE	DICOM Message Service Element
DIMSE-C	DICOM Message Service Element with Composite information objects

1.3.2 Abbreviations

ACR	American College of Radiology
AE	DICOM Application Entity
ASCII	American Standard Code for Information Interchange
DB	Database
DCS	DICOM Conformance Statement
FSC	File Set Creator
FSR	File Set Reader
FSU	File Set Updater
IOD	DICOM Information Object Definition
ISO	International Standard Organization
LEONARDO	AX-Workstation (for Angiographic/Radiographic viewing)
MOD	Magneto-optical Disk
NEMA	National Electrical Manufacturers Association
O	Optional Key Attribute
PDU	DICOM Protocol Data Unit
R	Required Key Attribute
RWA	Real-World Activity
U	Unique Key Attribute

1.4 References

- [1] Digital Imaging and Communications in Medicine (DICOM) 3.0, NEMA PS 3.1-15, 2000

^a *syngo* is a registered trademark of Siemens AG.

1.5 **Remarks**

DICOM, by itself, does not guarantee interoperability. However, the Conformance Statement facilitates a first-level validation for interoperability between different applications supporting the same DICOM functionality as SCU and SCP, respectively.

This Conformance Statement is not intended to replace validation with other DICOM equipment to ensure proper exchange of information intended.

The scope of this Conformance Statement is to facilitate communication with e.soft and other vendors' Medical equipment. The Conformance Statement should be read and understood in conjunction with the DICOM 3.0 Standard [DICOM]. However, by itself it is not guaranteed to ensure the desired interoperability and a successful interconnectivity.

The user should be aware of the following important issues:

- The comparison of different conformance statements is the first step towards assessing interconnectivity between e.soft and non-e.soft equipment.
- Test procedures should be defined and tests should be performed by the user to validate the connectivity desired. DICOM itself and the conformance parts do not specify this.
- The standard will evolve to meet the users' future requirements. syngo is actively involved in developing the standard further and therefore reserves the right to make changes to its products or to discontinue its delivery.
- syngo reserves the right to modify the design and specifications contained herein without prior notice. Please contact your local sales representative for the most recent product information.

2 Implementation Model

2.1 Application Data Flow Diagram

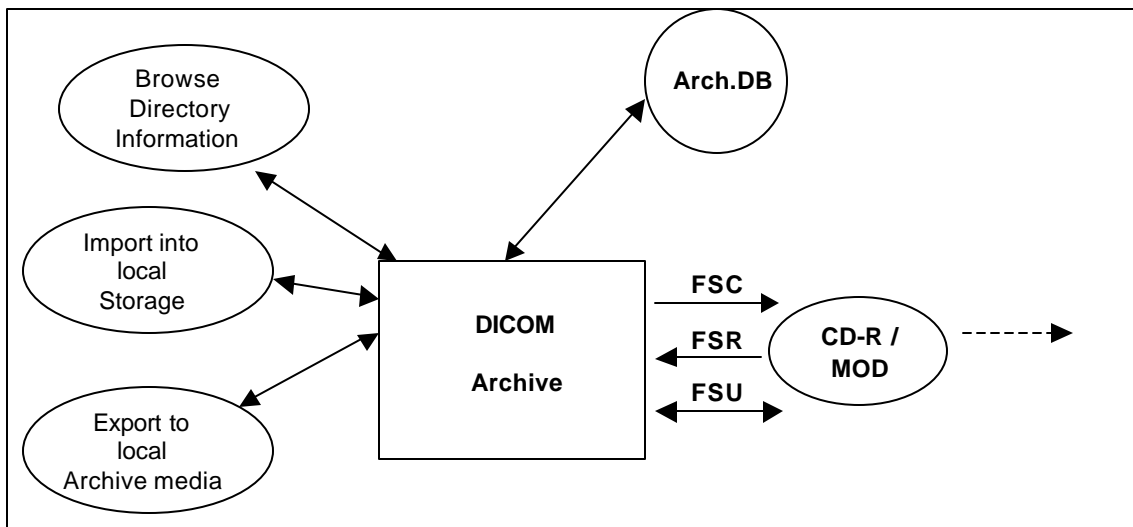

The DICOM archive application will serve as an interface to the CD-R offline medium device. It serves interfaces to include the offline media directory into the browser and to copy SOP instances to a medium or retrieve SOP Instances from medium into local storage.

The DICOM Archive application will support the 120mm CD-R medium and the 130mm 4.1 GB R/W MOD and 1.44 MB diskette media.

The FSU role will update new SOP Instances only to media with pre-existing File-sets conforming to the Application Profiles supported.

The contents of the DICOMDIR will be temporarily stored in Archive-Database.

2.2 Functional Definitions of AEs

The e.soft DICOM offline media storage application consists of the DICOM Archive application entity serving all interfaces to access offline media. The DICOM Archive application is capable of

1. creating a new File-set onto an unwritten medium (Export to...).
2. updating an existing File-set by writing new SOP Instances onto the medium (Export to...).
3. importing SOP Instances from the medium onto local storage
4. reading the File-sets DICOMDIR information into temporary database and pass it to display applications.

2.3 Sequencing of Real-World Activities

The DICOM Archive application will not perform updates before the Directory information of the DICOMDIR is completely read.

When performing updates, the SOP instances are checked for existence before updating. Duplicate instances will be avoided.

2.4 File Meta Information Options

Implementation Class UID	1.3.12.2.1107.5.9.20000101
Implementation Version Name	SIEMENS_SWFVD20K

3 AE Specifications

3.1 DICOM Archive Specification

The DICOM Archive provides Standard conformance to Media Storage Service Class (Interchange Option). In addition Augmented conformance is provided to store extra data attributes important for the full feature support of the e.soft product SW. Details are listed in following Table:

Application Profiles Supported	Real-World Activity	Role	SC Option
PRI-SYNGO-CD PRI-SYNGO-MOD41 (option) PRI-SYNGO-FD	Browse Directory Information	FSR	Interchange
AUG-GEN-CD *1	Import into local Storage	FSR	Interchange
AUG-CTMR-CD *1 AUG-XA1K-CD *1	Export to local Archive Media	FSC, FSU	Interchange
STDGEN-CD	Browse Directory Information	FSR	Interchange
STD-CTMR-CD STD-XABC-CD STD-XA1K-CD STD-US-zz-yF-xxxxxx *2 STD-WVFM-GENFD	Import into local Storage	FSR	Interchange

*1 – With no Private SOP Class used, the PRI -SYNGO-CD profile definitions are appropriate to describe the augmentation of the related -STD Profiles.

*2 - All combinations of the following values for xx, yF and xxxxxx are supported: yF={SF|MF}, xx={ID|SC|CC}, xxxxxx={FLOP|MOD128|MOD230|MOD540|MOD650|MOD12|MOD23|DVD-RAM|CDR}

On syngo-based products the Private Extended *syngo* Profile (PRI-SYNGO-CD or optional PRI-SYNGO-MOD41 or PRI-SYNGO-FD) will be preferably used by the system. The General Purpose Interchange Profile (STD-GEN-CD), Ultrasound Profile (STD-US-xxx), CT and MR Image Profile (STD-CTMR-xxx), Waveform Interchange (STD-WVFM-xxx), Basic Cardiac Profile (STD-XABC-CD) and 1024 X-Ray Angiographic Profile (STD-XA1K-CD) will be supported with read capability of the related media.

3.1.1 File Meta Information for the Application Entity

The Source Application Entity Title is set by configuration. See Chapter “Configuration” for details.

3.1.2 Real-World Activities for this Application Entity

3.1.2.1 Real-World Activity: Browse Directory Information

The DICOM Archive application acts as FSR using the interchange option when requested to read the media directory.

The DICOM archive application will read the DICOMDIR and insert those directory entries, that are valid for the application profiles supported, into a local database. The database can then be used for browsing media contents.

- Note

IconImageSQ is also supported in DICOMDIR. But only those Icon Images with BitsAllocated (0028,0100) equal to 8 and size of 64x64 or 128x128 pixels are imported into database and are visible in the Browser.

3.1.2.1.1 Application Profiles for the RWA: Browse Directory Information

See Table in section 3.1 for the Application Profiles listed that invoke this Application Entity for the Browse Directory Information RWA.

3.1.2.2 Real-World Activity: Import into local Storage

The DICOM Archive application acts as FSR using the interchange option when requested to read SOP Instances from the medium into the local storage.

The SOP Instance selected from the media directory will be copied into the local storage. Only SOP Instances, that are valid for the application profile supported and are listed as supported by the Storage SCP Conformance section (Network DCS, 5.1.3), can be retrieved from media storage. This is due to the fact that the Browse Directory Information will filter all SOP Instances not matching the Application profiles supported.

During operation no "Attribute Value Precedence" is applied to the SOP Instances. Detached Patient Management is not supported (please refer to DICOM Part 11, Media Storage Application Profiles).

For media conforming to the STD -GEN-CD Profile the following SOP classes will be supported as an FSR:

Information Object Definition	SOP Class UID	Transfer Syntax UID
CR Image	1.2.840.10008.5.1.4.1.1.1	Explicit VR Little Endian Uncompressed 1.2.840.10008.1.2.1
CT image	1.2.840.10008.5.1.4.1.1.2	Explicit VR Little Endian Uncompressed 1.2.840.10008.1.2.1
DX Image-For Processing	1.2.840.10008.5.1.4.1.1.1.1	Explicit VR Little Endian Uncompressed 1.2.840.10008.1.2.1
DX Image-For Presentation	1.2.840.10008.5.1.4.1.1.1.1	Explicit VR Little Endian Uncompressed 1.2.840.10008.1.2.1
IOX Image-For Processing	1.2.840.10008.5.1.4.1.1.1.3.1	Explicit VR Little Endian Uncompressed 1.2.840.10008.1.2.1
IOX Image-For Presentation	1.2.840.10008.5.1.4.1.1.1.3	Explicit VR Little Endian Uncompressed 1.2.840.10008.1.2.1
MG Image-For Processing	1.2.840.10008.5.1.4.1.1.2.1	Explicit VR Little Endian Uncompressed 1.2.840.10008.1.2.1
MG Image-For Presentation	1.2.840.10008.5.1.4.1.1.2	Explicit VR Little Endian Uncompressed 1.2.840.10008.1.2.1
MR Image	1.2.840.10008.5.1.4.1.1.4	Explicit VR Little Endian Uncompressed 1.2.840.10008.1.2.1
NM Image	1.2.840.10008.5.1.4.1.1.20	Explicit VR Little Endian Uncompressed 1.2.840.10008.1.2.1
PET Image	1.2.840.10008.5.1.4.1.1.128	Explicit VR Little Endian Uncompressed 1.2.840.10008.1.2.1
RT Dose	1.2.840.10008.5.1.4.1.1.481.2	Explicit VR Little Endian Uncompressed 1.2.840.10008.1.2.1
RT Image	1.2.840.10008.5.1.4.1.1.481.1	Explicit VR Little Endian Uncompressed 1.2.840.10008.1.2.1
RT Plan	1.2.840.10008.5.1.4.1.1.481.5	Explicit VR Little Endian Uncompressed 1.2.840.10008.1.2.1
RT Structure Set	1.2.840.10008.5.1.4.1.1.481.3	Explicit VR Little Endian Uncompressed 1.2.840.10008.1.2.1

Secondary Capture Image	1.2.840.10008.5.1.4.1.1.7	Explicit VR Little Endian Uncompressed 1.2.840.10008.1.2.1
Ultrasound Image (retired)	1.2.840.10008.5.1.4.1.1.6	Explicit VR Little Endian Uncompressed 1.2.840.10008.1.2.1
Ultrasound Image	1.2.840.10008.5.1.4.1.1.6.1	Explicit VR Little Endian Uncompressed 1.2.840.10008.1.2.1
Ultrasound Multi-frame Image (retired)	1.2.840.10008.5.1.4.1.1.3	Explicit VR Little Endian Uncompressed 1.2.840.10008.1.2.1
Ultrasound Multi-frame Image	1.2.840.10008.5.1.4.1.1.3.1	Explicit VR Little Endian Uncompressed 1.2.840.10008.1.2.1
X-Ray Angiographic Image	1.2.840.10008.5.1.4.1.1.12.1	Explicit VR Little Endian Uncompressed 1.2.840.10008.1.2.1
X-Ray Radiofluoroscopic Image	1.2.840.10008.5.1.4.1.1.12.2	Explicit VR Little Endian Uncompressed 1.2.840.10008.1.2.1
12-lead ECG Waveform Storage	1.2.840.10008.5.1.4.1.1.9.1.1	Explicit VR Little Endian Uncompressed 1.2.840.10008.1.2.1
Ambulatory ECG Waveform Storage	1.2.840.10008.5.1.4.1.1.9.1.3	Explicit VR Little Endian Uncompressed 1.2.840.10008.1.2.1
Basic Voice Audio Waveform Storage	1.2.840.10008.5.1.4.1.1.9.4.1	Explicit VR Little Endian Uncompressed 1.2.840.10008.1.2.1
Cardiac Electrophysiology Waveform Storage	1.2.840.10008.5.1.4.1.1.9.3.1	Explicit VR Little Endian Uncompressed 1.2.840.10008.1.2.1
General ECG Waveform Storage	1.2.840.10008.5.1.4.1.1.9.1.2	Explicit VR Little Endian Uncompressed 1.2.840.10008.1.2.1
Hemodynamic Waveform Storage	1.2.840.10008.5.1.4.1.1.9.2.1	Explicit VR Little Endian Uncompressed 1.2.840.10008.1.2.1
CSA Non-Image	1.3.12.2.1107.5.9.1	Explicit VR Little Endian Uncompressed 1.2.840.10008.1.2.1

3.1.2.2.1 Application Profiles for the RWA: Import into local Storage

See Table in section 3.1 for the Application Profiles listed that invoke this Application Entity for the Import into Local Storage RWA.

3.1.2.3 Real-World Activity: Export to local Archive Media

The DICOM Archive application acts as FSU (for media with existing DICOM file-set) or FSC (media not initialized) using the interchange option when requested to copy SOP Instances from the local storage to local Archive Medium.

The DICOM Archive application will receive a list of SOP Instances to be copied to the local archive medium. According to the state of the medium inserted (new medium, Medium with DICOM file-set) the validity of the SOP Instances according to the applicable profile is checked. Only valid SOP Instances are accepted.

When the DICOM archive application is requested to copy SOP Instances the preferred application profile according configuration (<modify AUG-XA1K-CD> or PRI-SYNGO-xxx) will be used to validate and copy the referred SOP Instances. When creating a new file-set no Descriptor File will be allocated and the related ID is not used.

The DICOM archive application will not close the medium.

3.1.2.3.1 Application Profiles for the RWA: Export to local Archive Media

See Table in section 3.1 for the Application Profiles listed that invoke this Application Entity for the Export to local Archive Media RWA.

4 Augmented and Private Profiles

4.1 Augmented Application Profiles

4.1.1 AUG-GEN-CD

With no private Siemens Non-Images stored onto Medium, the definitions of the PRI-SYNGO-CD Profile are applicable to denote the augmentations for the STD-GEN-CD Standard Profile.

Storage of Private Information Objects will only be supported with reference to a Private Application Profile (see next section).

The Siemens non-image is typically used for raw data and 3D private data.

).

4.1.2 AUG-XA1K-CD

With no private Siemens Non-Images stored onto Medium, the definitions of the PRI-SYNGO-CD Profile are applicable to denote the augmentations for the STD-XA1K-CD Standard Profile.

Storage of Private Information Objects will only be supported with reference to a Private Application Profile (see other section).

4.2 *syngo*® private offline Media Application Profile

Will contain a *syngo* specific Application Profile.

Structure of this Application Profile is defined in Part 11 of the 2000 DICOM Standard.

It is needed to describe the requirements for Offline Media Storage of the private IOD (Non-Image IOD).

4.2.1 Class and Profile Identification

This document defines an Application Profile Class for "*syngo*® speaking^a" modalities or applications.

The identifier for this class shall be PRI-SYNGO. This class is intended to be used for interchange of extended and private Information Objects via CD-R or re-writeable magneto-optical disk (MOD) offline media between dedicated acquisition or workstation modalities build from a common *syngo* architecture.

The specific application profiles in this class are shown in Table below:

Application Profile	Identifier	Description
" <i>syngo</i> speaking" System on CD-R	PRI-SYNGO-CD	Handles interchange of Composite SOP Instances and privately defined SOP Instances (Siemens

^a *syngo* is a registered trademark of Siemens AG.

		Non-Image IOD).
"syngo speaking" System on 4.1 GB MOD ^a	PRI-SYNGO-MOD41	Handles interchange of Composite SOP Instances and privately defined SOP Instances (Siemens Non-Image IOD).
"syngo speaking" System on Floppy Disk	PRI-SYNGO-FD	Handles interchange of Waveform SOP Instances and privately defined SOP Instances (Siemens Non-Image IOD).

Equipment claiming conformance for this syngo Application Profile Class shall make a clear statement on handling of the private defined SOP Instances.

4.2.2 Clinical Context

This application profile facilitates the interchange of original acquired and derived images and private data related to them. Typical media interchange would be from in-lab acquisition equipment to dedicated workstations and archive systems with specific extensions to handle the private data objects (in both directions).

Additionally, images (from MR,CT,US,NM,DX,RF) used to prepare procedures, multi-modality images (e.g. integrated US) and images derived from primary diagnostic images, such as annotations, quantitative analysis images, reference images, screen capture images may be interchanged via this profile.

4.2.2.1 Roles and Service Class Options

This Application Profile uses the Media Storage Service Class defined in PS 3.4 with the Interchange Option.

The Application Entity shall support one or more of the roles of File Set Creator (FSC), File Set Reader (FSR), and File Set Updater (FSU), defined in PS 3.10.

4.2.2.1.1 File Set Creator

The Application Entity acting as a File Set Creator generates a File Set under the PRI-SYNGO Application Profiles.

File Set Creators shall be able to generate the Basic Directory SOP Class in the DICOMDIR file with all the subsidiary Directory Records related to the Image SOP Classes and Private SOP Classes stored in the File Set.

In case of the PRI-SYNGO-CD profile, the FSC shall offer the ability to either finalize the disc at the completion of the most recent write session (no additional information can be subsequently added to the disc) or to allow multi-session (additional information may be subsequently added to the disc).

Note

A multiple volume (a logical volume that can cross multiple physical media) is not supported by this Application Profile Class. If a set of Files, e.g., a Study, cannot be written entirely on one CD-R, the FSC will create multiple independent DICOM File-Set such that each File-Set can reside on a single CD-R medium controlled by its individual DICOMDIR file. The user of the FSC can opt to use written labels on the discs to reflect that there is more than one disc for this set of files (e.g., a Study).

^a Definition of this profile is done due to approval of DICOM Supplement 62.

4.2.2.1.2 File Set Reader

The role of the File Set Reader shall be used by Application Entities which receive the transferred File Set.

File Set Readers shall be able to read all the defined SOP Instances files defined for the specific Application Profiles to which a conformance claim is made, using all the defined Transfer Syntaxes.

4.2.2.1.3 File Set Updater

The role of the File Set Updater shall be used by Application Entities, which receive a transferred File Set and update it by the addition of processed information.

File Set Updaters shall be able to read and update the DICOMDIR file. File-Set Updaters do not have to read the image/private information objects. File-Set Updaters shall be able to generate any of the SOP Instances files defined for the specific Application Profiles to which a conformance claim is made, and to read and update the DICOMDIR file.

In case of the PRI-SYNGO-CD profile, the FSU shall offer the ability to either finalize a disc at the completion of the most recent write session (no additional information can be subsequently added to the disc) or to allow multi-session (additional information may be subsequently added to the disc).

Note (for CD-R)

If the disc has not been finalized, the File-Set Updater will be able to update information assuming there is enough space on the disc to write a new DICOMDIR file, the information, and the fundamental CD-R control structures. CD-R control structures are the structures that inherent to the CD-R standards; see PS 3.12

4.2.3 PRI-SYNGO Profiles

4.2.3.1 SOP Classes and transfer Syntaxes

These Application Profiles are based on the Media Storage Service Class with the Interchange Option. In the table below Transfer Syntax UID "RLE Lossless " applies only for decompression.

Information Object Definition	SOP Class UID	Transfer Syntax UID	FSC	FSR	FSU
Basic Directory	1.2.840.10008.1.3.10	Explicit VR Little Endian Uncompressed 1.2.840.10008.1.2.1	M	M	M
CR Image	1.2.840.10008.5.1.4.1.1.1	Explicit VR Little Endian Uncompressed 1.2.840.10008.1.2.1	M	M	O
CT image	1.2.840.10008.5.1.4.1.1.2	Explicit VR Little Endian Uncompressed 1.2.840.10008.1.2.1	M	M	O
DX Image – For Processing	1.2.840.10008.5.1.4.1.1.1.1	Explicit VR Little Endian Uncompressed 1.2.840.10008.1.2.1	M	M	O
DX Image – For Presentation	1.2.840.10008.5.1.4.1.1.1.1	Explicit VR Little Endian Uncompressed 1.2.840.10008.1.2.1	M	M	O
MG Image – For Processing	1.2.840.10008.5.1.4.1.1.1.2.1	Explicit VR Little Endian Uncompressed 1.2.840.10008.1.2.1	M	M	O
IOX Image – For Processing	1.2.840.10008.5.1.4.1.1.1.3.1	Explicit VR Little Endian Uncompressed 1.2.840.10008.1.2.1	M	M	O
IOX Image – For Presentation	1.2.840.10008.5.1.4.1.1.1.3	Explicit VR Little Endian Uncompressed 1.2.840.10008.1.2.1	M	M	O

Information Object Definition	SOP Class UID	Transfer Syntax UID	FSC	FSR	FSU
MR Image	1.2.840.10008.5.1.4.1.1.4	Explicit VR Little Endian Uncompressed 1.2.840.10008.1.2.1	M	M	O
MR Image	1.2.840.10008.5.1.4.1.1.4	Explicit VR Big Endian Uncompressed 1.2.840.10008.1.2.2	O	M	O
NM Image	1.2.840.10008.5.1.4.1.1.20	Explicit VR Big Endian Uncompressed 1.2.840.10008.1.2.2	O	M	O
PET Image	1.2.840.10008.5.1.4.1.1.128	Explicit VR Little Endian Uncompressed 1.2.840.10008.1.2.1	M	M	O
RT Dose	1.2.840.10008.5.1.4.1.1.481.2	Explicit VR Little Endian Uncompressed 1.2.840.10008.1.2.1	M	M	O
RT Dose	1.2.840.10008.5.1.4.1.1.481.2	Explicit VR Big Endian Uncompressed 1.2.840.10008.1.2.2	O	M	O
RT Image	1.2.840.10008.5.1.4.1.1.481.1	Explicit VR Little Endian Uncompressed 1.2.840.10008.1.2.1	M	M	O
RT Plan	1.2.840.10008.5.1.4.1.1.481.5	Explicit VR Little Endian Uncompressed 1.2.840.10008.1.2.1	M	M	O
RT Plan	1.2.840.10008.5.1.4.1.1.481.5	Explicit VR Big Endian Uncompressed 1.2.840.10008.1.2.2	O	M	O
RT Structure Set	1.2.840.10008.5.1.4.1.1.481.3	Explicit VR Little Endian Uncompressed 1.2.840.10008.1.2.1	M	M	O
RT Structure Set	1.2.840.10008.5.1.4.1.1.481.3	Explicit VR Big Endian Uncompressed 1.2.840.10008.1.2.2	O	M	O
Secondary Capture Image	1.2.840.10008.5.1.4.1.1.7	Explicit VR Little Endian Uncompressed 1.2.840.10008.1.2.1	M	M	O
Ultrasound Image (retired)	1.2.840.10008.5.1.4.1.1.6	Explicit VR Little Endian Uncompressed 1.2.840.10008.1.2.1	-	M	-
Ultrasound Image	1.2.840.10008.5.1.4.1.1.6.1	Explicit VR Little Endian Uncompressed 1.2.840.10008.1.2.1	M	M	O
Ultrasound Multi-frame Image (retired)	1.2.840.10008.5.1.4.1.1.3	Explicit VR Little Endian Uncompressed 1.2.840.10008.1.2.1	-	M	-
Ultrasound Multi-frame Image (retired)	1.2.840.10008.5.1.4.1.1.3	Explicit VR Big Endian Uncompressed 1.2.840.10008.1.2.2	-	M	-
Ultrasound Multi-frame Image	1.2.840.10008.5.1.4.1.1.3.1	Explicit VR Little Endian Uncompressed 1.2.840.10008.1.2.1	M	M	O
Ultrasound Multi-frame Image	1.2.840.10008.5.1.4.1.1.3.1	Explicit VR Big Endian Uncompressed 1.2.840.10008.1.2.2	O	M	O
X-Ray Angiographic Image	1.2.840.10008.5.1.4.1.1.12.1	Explicit VR Little Endian Uncompressed 1.2.840.10008.1.2.1	O	M	O
X-Ray Angiographic Image	1.2.840.10008.5.1.4.1.1.12.1	Explicit VR Big Endian Uncompressed 1.2.840.10008.1.2.2	O	M	O
X-Ray Radiofluoroscopic Image	1.2.840.10008.5.1.4.1.1.12.2	Explicit VR Little Endian Uncompressed 1.2.840.10008.1.2.1	O	M	O
X-Ray Radiofluoroscopic Image	1.2.840.10008.5.1.4.1.1.12.2	Explicit VR Big Endian Uncompressed 1.2.840.10008.1.2.2	O	M	O
Waveform Storage SOP Classes	1.2.840.10008.5.1.4.1.1.9.1.1 1.2.840.10008.5.1.4.1.1.9.1.2 1.2.840.10008.5.1.4.1.1.9.1.3 1.2.840.10008.5.1.4.1.1.9.2.1 1.2.840.10008.5.1.4.1.1.9.3.1 1.2.840.10008.5.1.4.1.1.9.4.1	Explicit VR Little Endian Uncompressed 1.2.840.10008.1.2.1	M	M	O

Information Object Definition	SOP Class UID	Transfer Syntax UID	FSC	FSR	FSU
Waveform Storage SOP Classes	1.2.840.10008.5.1.4.1.1.9.1.1 1.2.840.10008.5.1.4.1.1.9.1.2 1.2.840.10008.5.1.4.1.1.9.1.3 1.2.840.10008.5.1.4.1.1.9.2.1 1.2.840.10008.5.1.4.1.1.9.3.1 1.2.840.10008.5.1.4.1.1.9.4.1	Explicit VR Big Endian Uncompressed 1.2.840.10008.1.2.2	O	M	O
CSA Non-Image	1.3.12.2.1107.5.9.1	Explicit VR Little Endian Uncompressed 1.2.840.10008.1.2.1	O	M	O
Detached Patient Management	1.2.840.10008.3.1.2.1.1	Explicit VR Little Endian Uncompressed 1.2.840.10008.1.2.1	O	see DCS	O

FSC, FSR, FSU– denote the requirements for those roles

O – Optional
M - Mandatory

4.2.3.2 Physical Media and Formats

The PRI-SYNGO-CD Profile requires the 120mm CD-R physical media with the ISO/IEC 9660 Media Format, as defined in PS3.12.

The PRI-SYNGO-MOD41 Profile requires the 130mm 4.1 GB R/W MOD physical medium with the PCDOS Media Format, as defined in PS 3.12.

The PRI-SYNGO-FD Profile requires the 1.44 MB diskette physical medium with the PCDOS Media Format, as defined in PS3.12.

4.2.3.3 Directory Information in DICOMDIR

Conforming Application Entities shall include in the DICOMDIR File the Basic Directory IOD containing Directory Records at the Patient and subsidiary levels appropriate to the SOP Classes in the File-set. All DICOM files in the File -set incorporating SOP Instances defined for the specific Application profile, shall be referenced by Directory Records.

Note

DICOMDIRs with no directory information are not allowed by this Application Profile

Privately defined IODs will be referenced by "PRIVATE" Directory Records.

4.2.3.3.1 Basic Directory IOD Specialization

This Application Profile makes use of optional attributes of the Basic Directory IOD to support recognition of Patient's Storage Service request results in spanning multiple volumes (file sets). Therefore the File Set Descriptor File can be used and is then referenced by optional Basic Directory IOD attributes. If existent, the specified Descriptor File may be used by FSR applications. Any FSU, FSC shall make a clear Statement if the Descriptor File mechanism is used according to the specialization defined in this Application Profile.

The Descriptor Files shall have the following contents:

One single Line without any control-characters and according to the Basic Character-Set having the following defined text:

"MULTIVOLUME: xx of yy"

xx, yy are replaced by the actual Number of the volume (xx) and the Total Number of Volumes in the set (yy).

If used, the Descriptor File shall have the File ID "README" and reside in same directory level as the DICOMDIR. It is referenced by the attribute [0004,1141] File-set Descriptor File ID having the defined content of "README".

4.2.3.3.2 Additional Keys

File-set Creators and Updaters are required to generate the mandatory elements specified in PS 3.3, Annex F of the DICOM Standard. Table below:PRI-SYNGO-CD Additional DICOMDIR Keys specifies the additional associated keys. At each directory record level other additional data elements can be added, but it is not required that File Set Readers be able to use them as keys. Refer to the Basic Directory IOD in PS 3.3.

Key Attribute	Tag	Directory Record Level	Type	Notes
Date of Birth	(0010,0030)	PATIENT	2C	required, if present in SOP Instance
Patient's Sex	(0010,0040)	PATIENT	2C	required, if present in SOP Instance
Series Date	(0008,0021)	SERIES	3	
Series Time	(0008,0031)	SERIES	3	
Institute Name	(0008,0080)	SERIES	2C	required, if present in SOP Instance
Institution Address	(0008,0081)	SERIES	2C	required, if present in SOP Instance
Series Description	(0008,103E)	SERIES	3	
Performing Physician's Name	(0008,1050)	SERIES	2C	required, if present in SOP Instance
Image Type	(0008,0008)	IMAGE	1C	required, if present in SOP Instance
SOP Class UID	(0008,0016)	IMAGE	3	
SOP Instance UID	(0008,0018)	IMAGE	3	
Image Date	(0008,0023)	IMAGE	3	
Image Time	(0008,0033)	IMAGE	3	
Referenced Image Sequence	(0008,1140)	IMAGE	1C	required, if present in SOP Instance
> Referenced SOP Class UID	(0008,1150)			
> Referenced SOP Instance UID	(0008,1155)			
Image Position (Patient)	(0020,0032)	IMAGE	2C	required, if present in SOP Instance
Image Orientation (Patient)	(0020,0037)	IMAGE	2C	required, if present in SOP Instance
Frame of Reference UID	(0020,0052)	IMAGE	2C	required, if present in SOP Instance
Rows	(0028,0010)	IMAGE	3	
Columns	(0028,0011)	IMAGE	3	
Pixel Spacing	(0028,0030)	IMAGE	1C	required, if present in SOP Instance
Calibration Image	(0050,0004)	IMAGE	2C	required, if present in SOP Instance
Icon Image Sequence	(0088,0200)	IMAGE	3	required for Image SOP Classes
> Samples per Pixel	(0028,0002)			1
> Photometric Interpretation	(0028,0004)			MONOCHROME2
> Rows	(0028,0010)			128 for XA, 64 for others
> Columns	(0028,0011)			128 for XA, 64 for others
> Bits Allocated	(0028,0100)			8
> Bits Stored	(0028,0101)			8
> High Bit	(0028,0102)			7
> Pixel Representation	(0028,0103)			0
> Pixel Data	(7FE0,0010)			Icon Image
Curve Number	(0020,0024)	CURVE	1C	required, if present in SOP Instance

4.2.3.3.3 Private Directory Record Keys

Private Directory Records are supported by this Application Profile Class at the following Level-IMAGE. The PRIVATE Directory Records will have required elements in addition to the mandatory elements specified in PS 3.3.

The following table will list the additional required keys for PRIVATE Directory Records:

Key Attribute	Tag	Directory Record Level	Type	Notes
Private Record UID	(0004,1432)	PRIVATE	1	See Conformance Statement
SOP Class UID	(0008,0016)	PRIVATE	1C	required, if present in SOP Instance
SOP Instance UID	(0008,0018)	PRIVATE	1C	required, if present in SOP Instance
Image Type	(0008,0008)	PRIVATE	3	
Acquisition Date	(0008,0022)	PRIVATE	3	
Acquisition Time	(0008,0032)	PRIVATE	3	
Acquisition Number	(0020,0012)	PRIVATE	3	
CSA Data Type	(0029,xx08)	PRIVATE	1	private owner code = SIEMENS CSA NONIMAGE
CSA Data Version	(0029,xx09)	PRIVATE	3	private owner code = SIEMENS CSA NONIMAGE

4.2.3.3.4 Icon Images

Directory Records of type SERIES or IMAGE may include Icon Images. The Icon Image pixel data shall be as specified in PS 3.3 "Icon Image Key Definition", and restricted such, that Bits Allocated (0028,0100) and Bits Stored (0028,0101) shall be equal 8, and Rows (0028,0010) and Columns (0028,0011) shall be equal to 128 for XA Images and 64 for all other Images. The Photometric Interpretation (0028,0004) shall always be restricted to "MONOCHROME2".

PRIVATE Directory Records will not contain Icon Image information.

4.2.3.4 Other Parameters

This section defines other parameters common to all specific Application Profiles in the PRIVATE SYNGO class which need to be specified in order to ensure interoperable media interchange.

4.2.3.4.1 Multi-Frame JPEG Format

The JPEG encoding of pixel data shall use Interchange Format (with table specification) for all frames.

4.2.3.4.2 Attribute Value Precedence

The values of attributes contained in a Detached Patient Management SOP Instance referenced by a DICOMDIR PATIENT Directory Record shall take precedence over the values of those attributes contained in the SOP Instance referenced by a subsidiary Directory Record. The DICOMDIR Directory Records shall have key attribute values in accordance with this precedence.

Note

This allows patient identification and demographic information to be updated without changing the composite Image IOD files. The DICOMDIR file thus is critical in establishing the link between the updated information and the image. As an example, at the time an Image file was written, the patient's name therein was incorrect, or inconsistent with the Hospital Information System records. Subsequently, a Detached Patient Management file with the corrected name is added to the file-set. The FSR should use the name from the Patient File rather than in the Image File.

5 Extensions, Specialization and Privatization of SOP Classes and Transfer Syntaxes

The SOP Classes listed refer in majority to those created by the equipment to which this conformance Statement is related to. For SOP classes not listed in this section, please refer to the Storage section of the DICOM Conformance Statement of the product. This will include all SOP Instances that can be received and displayed and therefore will be included into offline media storage even though these SOP Instances are not created by the equipment serving the Media Storage Service.

5.1 SOP Specific Conformance Statement for Basic Directory

5.1.1 Extension, Specialization for SIEMENS Non-Image Objects

According to the PRI-SYNGO Application Profile Class the usage of the Private Creator U IDs and further optional keys for the Directory Records referring to SIEMENS Non-Image Objects are listed in the following tables.

Attribute	Tag	Value used
Private Record UID	(0004,1432)	1.3.12.2.1107.5.9.1
SOP Class UID	(0008,0016)	1.3.12.2.1107.5.9.1

For those "Non-Images" no Icon Image Sequence will be generated.

6 Configuration

6.1 AE Title Mapping

6.1.1 DICOM Media Storage AE Title

The DICOM Storage application provides the application entity title:

CsalmageManager

7 Support of Extended Character Sets

The Siemens e.soft DICOM archive application supports the ISO 8859 Latin 1 (ISO-IR 100) character set.

Also the Japanese language character sets JIS X 0201 (ISO-IR 13 Japanese katakana and ISO-IR 14 Japanese romaji), JIS X 0208 (ISO-IR 87 Japanese kanji) and JIS X 0212 (IOS-IR 159 Supplementary Japanese kanji) are supported.

When there is a mismatch between the SCS tags (0008,0005) and the characters in an IOD received by the system, then the following measures are taken to make the characters DICOM conform:

- Try to import with ISO_IR 100. If ISO_IR 100 fails, convert each illegal character to a '?'.

A ANNEX

A.1 SIEMENS Private Non-Image IOD

For encoding binary data-streams not representing image data, Siemens has created a private "Non-Image IOD" according to the rules governed by the DICOM Standard. The following section will roll-out the definition of this Private IOD. It can be communicated with Network Storage Service and Offline Media Storage Services.

The Siemens "Non-Image IOD" is identified by a private Non-Image Storage SOP Class UID of „1.3.12.2.1107.5.9.1“

A.1.1 Siemens Non-Image IOD – E-R Model

The E-R model in A.1.2 depicts those components of the DICOM Information Model which directly refer to the Siemens Non-Image IOD. The Frame of Reference IE, Overlay IE, Modality Lookup-Table IE, VOI Lookup-Table IE and Curve IE are not components of the Siemens Non-Image IOD.

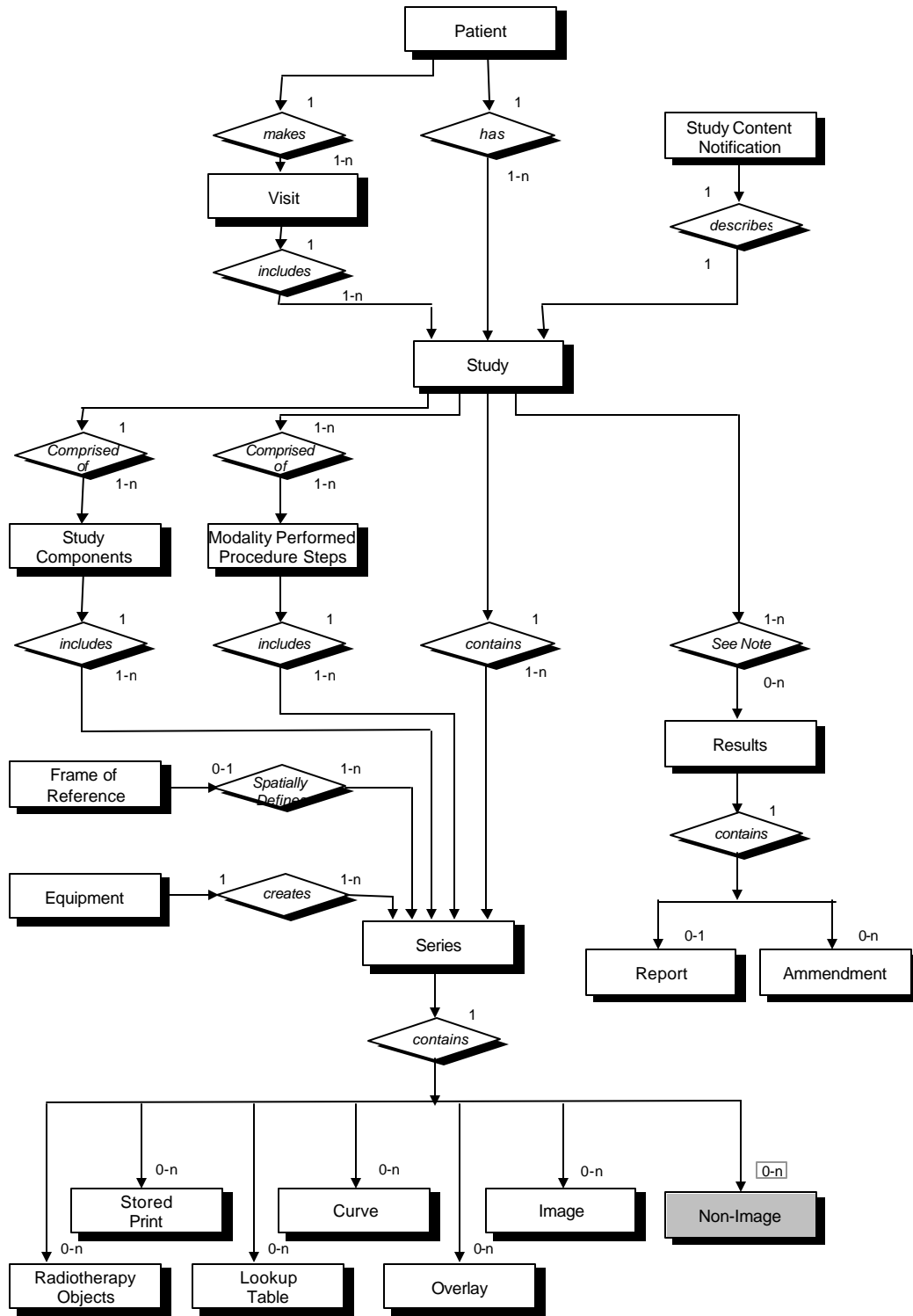

A.1.2 Siemens Non-Image IOD - Module Table

IE	Module	Reference	Usage
Patient	Patient	[1] PS3.3 C.7.1.1	M
Study	General Study	[1] PS3.3 C.7.2.1	M
	Patient Study	[1] PS3.3 C.7.2.2	U
Series	General Series	[1] PS3.3 C.7.3.1	M
Equipment	General Equipment	[1] PS3.3 C.7.5.1	U
CSA	CSA Image Header	A.2.1	U
	CSA Series Header	A.2.2	U
	MEDCOM Header	A.2.3	U
	CSA Non-Image	A.1.3.1	M
	SOP Common	[1] PS3.3 C.12.1	M

A.1.3 Siemens Non-Image IOD - Modules

A.1.3.1 CSA Non-Image Module

The table in this section contains private IOD Attributes that describe CSA Non -Images.

Attribute Name	Tag	Owner	Type	Notes
Image Type	(0008,0008)	-	3	Image identification characteristics.
Acquisition Date	(0008,0022)	-	3	The date the acquisition of data that resulted in this data set started.
Acquisition Time	(0008,0032)	-	3	The time the acquisition of data that resulted in this data set started.
Conversion Type	(0008,0064)	-	3	Describes the kind of image conversion. Defined Terms: DV = Digitized Video, DI = Digital Interface, DF = Digitized Film, WSD = Workstation.
Referenced Image Sequence	(0008,1140)	-	3	A sequence which provides reference to a set of Image SOP Class/Instance identifying other images significantly related to this data set. Encoded as sequence of items: (0008,1150) and (0008,1155).
Derivation Description	(0008,2111)	-	3	A text description of how this data set was derived.
Source Image Sequence	(0008,2112)	-	3	A Sequence which identifies the set of Image SOP Class/Instance pairs of the Images which were used to derive this data set. Zero or more Items may be included in this Sequence. Encoded as sequence of items: (0008,1150) and (0008,1155).
Patient Position	(0018,5100)	-	3	Patient position descriptor relative to the equipment.
Acquisition Number	(0020,0012)	-	3	A number identifying the single continuous gathering of data over a period of time which resulted in this data set.
Image Number	(0020,0013)	-	3	A number that identifies this data set.
Frame of Reference UID	(0020,0052)	-	3	Uniquely identifies the frame of reference for a Series.
Image Comments	(0020,4000)	-	3	User-defined comments about the image.
Quality Control Image	(0028,0300)	-	3	Indicates whether or not this image is a quality control or phantom image. If this Attribute is absent, then the

				image may or may not be a quality control or phantom image. Enumerated Values: YES, NO.
Burned in Annotation	(0028,0301)	-	3	Indicates whether or not image contains sufficient burned in annotation to identify the patient and date the image was acquired. If this Attribute is absent, then the image may or may not contain burned in annotation. Enumerated Values: YES, NO.
Lossy Image Compression	(0028,2110)	-	3	Specifies whether an Image has undergone lossy compression. Enumerated Values: 00 = Image has NOT been subjected to lossy compression, 01 = Image has been subjected to lossy compression.
Lossy Image Compression Ratio	(0028,2112)	-	3	Describes the approximate lossy compression ratio(s) that have been applied to this image. May be multi valued if successive lossy compression steps have been applied.
CSA Data Type	(0029,xx08)	SIEMENS CSA NON-IMAGE	1	CSA Data identification characteristics. Defined Terms: BSR REPORT = Study Report Data 3D EDITOR 3D FLY PATH = Fly Through Data 3D FLY VRT = Fly Through Data 3D FUSION MATRIX = Fusion Data RAW DATA NUM 4 = NUMARIS/ Raw Data RAW DATA SOM 5 = SOMARIS/ Raw Data RT3D CONFIG = InSpaceIS Data SPEC NUM 4 = NUMARIS/4 Spectroscopy
CSA Data Version	(0029,xx09)	SIEMENS CSA NON-IMAGE	3	Version of CSA Data Info (0029,xx10) format and CSA Non-Image Data (7FE1,xx10) format.
CSA Data Info	(0029,xx10)	SIEMENS CSA NON-IMAGE	3	Information to describe the CSA Data (7FE1,xx10).
CSA Data	(7FE1,xx10)	SIEMENS CSA NON-IMAGE	2	Binary data as byte stream.

A.2 Siemens Standard Extended Modules

<modify add own product specific modules in the table below if necessary>

IE	Module	Reference	Usage	Note
Image	CSA Image Header	A.2.1	U	private GG information
	CSA Series Header	A.2.2	U	
	MEDCOM Header	A.2.3	U	private syngo information
	MEDCOM OOG	A.2.4	U	if object graphics is attached to image

A.2.1 CSA Image Header Module

The table in this section contains private IOD Attributes that describe the CSA Image Header:

Attribute Name	Tag	Owner	Type	Notes
CSA Image Header Type	(0029,xx08)	SIEMENS CSA HEADER	1	CSA Image Header identification characteristics. Defined Terms: NUM 4 = NUMARIS/4 SOM 5 = SOMARIS/5
CSA Image Header Version	(0029,xx09)	SIEMENS CSA HEADER	3	Version of CSA Image Header Info (0029,xx10) format.
CSA Image Header Info	(0029,xx10)	SIEMENS CSA HEADER	3	Manufacturer model dependent information.

A.2.2 CSA Series Header Module

The table in this section contains private IOD Attributes that describe the CSA Series Header:

Attribute Name	Tag	Owner	Type	Notes
CSA Series Header Type	(0029,xx18)	SIEMENS CSA HEADER	1	CSA Series Header identification characteristics. Defined Terms: NUM 4 = NUMARIS/4
CSA Series Header Version	(0029,xx19)	SIEMENS CSA HEADER	3	Version of CSA Series Header Info (0029,xx20) format.
CSA Series Header Info	(0029,xx20)	SIEMENS CSA HEADER	3	Manufacturer model dependent information.

A.2.3 MEDCOM Header Module

The table in this section contains private IOD Attributes that describe MEDCOM Header:

Attribute Name	Tag	Owner	Type	Notes
MedCom Header Type	(0029,xx08)	SIEMENS MEDCOM HEADER	1C	MedCom Header identification characteristics. Defined Terms: MEDCOM 1 (Required if MedCom Header Info (0029,xx10) present.)
MedCom Header Version	(0029,xx09)	SIEMENS MEDCOM HEADER	2C	Version of MedCom Header Info (0029,xx10) format. (Required if MEDCOM Header Info (0029,xx10) present.)
MedCom Header Info	(0029,xx10)	SIEMENS MEDCOM HEADER	3	Manufacturer model dependent information. The value of the attribute MedCom Header Info (0029,xx10) can be build up in each user defined format.
MedCom History Information	(0029,xx20)	SIEMENS MEDCOM HEADER	3	MedCom defined Patient Registration history information. See A.2.3.1.
PMTF Information 1	(0029,xx31)	SIEMENS MEDCOM HEADER	3	Transformation Information
PMTF Information 2	(0029,xx32)	SIEMENS MEDCOM HEADER	3	Transformation Information
PMTF Information 3	(0029,xx33)	SIEMENS MEDCOM HEADER	3	Transformation Information
PMTF Information 4	(0029,xx34)	SIEMENS MEDCOM HEADER	3	Transformation Information
PMTF Information 5	(0029,xx35)	SIEMENS MEDCOM HEADER	3	Transformation Information
Application Header Sequence	(0029,xx40)	SIEMENS MEDCOM HEADER	3	Sequence of Application Header items. Zero or more items are possible.
>Application Header Type	(0029,xx41)	SIEMENS MEDCOM HEADER	1C	Application Header identification characteristics. Required, if Sequence is sent.
>Application Header ID	(0029,xx42)	SIEMENS MEDCOM HEADER	3	Identification of an application header
>Application Header Version	(0029,xx43)	SIEMENS MEDCOM HEADER	3	Version of CSA Series Header Info (0029,xx44) format.
>Application Header Info	(0029,xx44)	SIEMENS MEDCOM HEADER	3	Application dependent information.

Workflow Control Flags	(0029,xx50)	SIEMENS MEDCOM HEADER	3	Eight free definable flags.
Archive Management Flag Keep Online	(0029,xx51)	SIEMENS MEDCOM HEADER	3	Flag to control remote archive management system to keep the image always online (also when already archived). Enumerated Values: 00 = remote control not required 01 = keep image online
Archive Management Flag Do Not Archive	(0029,xx52)	SIEMENS MEDCOM HEADER	3	Flag to control remote archive management system not to archive the related image. Enumerated Values: 00 = remote control not required 01 = don't archive image
Image Location Status	(0029,xx53)	SIEMENS MEDCOM HEADER	3	Image location status to control retrieving. Defined Terms: ONLINE = retrieving has to be done as usual, NEARLINE = move request to SCP and delay according to value of Estimated Retrieve Time (0029,xx54), OFFLINE = invoking a retrieve operation initiates an operator request, INVALID = invoking a retrieve operation would always result in an error.
Estimated Retrieve Time	(0029,xx54)	SIEMENS MEDCOM HEADER	3	Estimated retrieve time in seconds. A value less than zero (< 0) indicates location is OFFLINE or INVALID.
Data Size of Retrieved Images	(0029,xx55)	SIEMENS MEDCOM HEADER	3	Data size of images in MByte.

A.2.3.1 MEDCOM History Information

The value of the attribute MEDCOM History Information (0029,xx20) is defined in the following way:

Part	Name	Type	Bytes	Notes
header	Identifier	string	32	Always "CSA HISTORY"
	Version	string	32	e.g. "V1.10"
n Items	Class Name	string	64	
	Modification String	string	1024	

A.2.4 MEDCOM OOG Module

The table in this section contains private IOD Attributes that describe MEDCOM Object Oriented Graphics (OOG). This module is used whenever object graphics is drawn on the image and need to be stored as graphic object properties. Given the condition that the module contents was not removed by other modalities, the graphic objects remain re-animatable if such an image was transferred and is then retrieved back

Attribute Name	Tag	Owner	Type	Notes
MedCom OOG Type	(0029,xx08)	SIEMENS MEDCOM OOG	1	MEDCOM Object Oriented Graphics (OOG) identification characteristics. Defined Terms: MEDCOM OOG 1 MEDCOM OOG 2
MedCom OOG Version	(0029,xx09)	SIEMENS MEDCOM OOG	3	Version of MEDCOM OOG Info (0029,xx10) format.
MedCom OOG Info	(0029,xx10)	SIEMENS MEDCOM OOG	3	MEDCOM Object Oriented Graphics (OOG) data.

The graphics objects are also fully drawn in the Image Overlay Plane for compatibility with other products, which do not support the MedCom OOG module. Any system not supporting the MedCom OOG module shall remove the OOG module and its contents when modifying the image overlay plane content.

<modify and add your own Modules here, each under one heading, the below "Angio Viewing Module is left as a sample. Please modify or remove it. >

A.2.5 *syngo* Report Data

The module contains private IOD Attributes that describe *syngo* reports. This module is used when *syngo* report data are added to DICOM SR and DICOM SC objects.

Attribute Name	Tag	Owner	Type	Notes
<i>syngo</i> Report Type	(0029,xx08)	SIEMENS CSA REPORT	1	<i>syngo</i> report characteristics, e.g. report creating application. Defined Terms: CT_LUNGCARE MR_ARGUS This attribute value will be used to identify the corresponding application during generic extension dll management. A restricted character set is used: only A-Z and underscore are supported.
<i>syngo</i> Report Version	(0029,xx09)	SIEMENS CSA REPORT	3	Version of <i>syngo</i> Report Data (0029,xx10) format.
<i>syngo</i> Report Data	(0029,xx10)	SIEMENS CSA ENVELOPE	3	A representation of DICOM SR Attribute Content Sequence (0040,A730). This includes the document relationship and document content. This data will typically be represented using an XML encoding according to a Siemens private scheme.
<i>syngo</i> Report Presentation	(0029,xx11)	SIEMENS CSA ENVELOPE	3	A representation of the recommended presentation for the <i>syngo</i> Report Data (0029,xx10). This presentation will typically be encoded in XSLT.
SR Variant	(0029,xx15)	SIEMENS CSA REPORT		DICOM SR variant. Enumerated Values: 0 = Basic Text SR (1.2.840.10008.5.1.4.1.1.88.11) 1 = Enhanced SR (1.2.840.10008.5.1.4.1.1.88.22) 2 = Comprehensive SR (1.2.840.10008.5.1.4.1.1.88.33) 3 = Mammography CAD SR (1.2.840.10008.5.1.4.1.1.88.50) 4 = Key Object Selection Document (1.2.840.10008.5.1.4.1.1.88.59)
SC SOP Instance UID	(0029,xx17)	SIEMENS CSA REPORT	3	DICOM SOP Instance UID of <i>syngo</i> based SC Image representing the <i>syngo</i> report object. This UID will be used to identify the Resulting SC object after SR to SC conversion.

A.2.6 *syngo* Report Info

The module *syngo* Report Info contains all DICOM SR attributes except the Contents Sequence (0040,A730). This module is only used during SR to SC conversion.

A.3 Registry of DICOM Data Elements

<modify this table and add your own attribute, if needed>

Tag	Private Owner Code	Name	VR	VM
(0029,xx08)	SIEMENS CSA NON-IMAGE	CSA Data Type	CS	1
(0029,xx09)	SIEMENS CSA NON-IMAGE	CSA Data Version	LO	1
(0029,xx10)	SIEMENS CSA NON-IMAGE	CSA Data Info	OB	1
(0029,xx08)	SIEMENS CSA HEADER	CSA Image Header Type	CS	1
(0029,xx09)	SIEMENS CSA HEADER	CSA Image Header Version	LO	1
(0029,xx10)	SIEMENS CSA HEADER	CSA Image Header Info	OB	1
(0029,xx18)	SIEMENS CSA HEADER	CSA Series Header Type	CS	1
(0029,xx19)	SIEMENS CSA HEADER	CSA Series Header Version	LO	1
(0029,xx20)	SIEMENS CSA HEADER	CSA Series Header Info	OB	1
(0029,xx08)	SIEMENS CSA REPORT	syngo Report Type	CS	1
(0029,xx09)	SIEMENS CSA REPORT	syngo Report	LO	1
(0029,xx15)	SIEMENS CSA REPORT	SR Variant	US	1
(0029,xx17)	SIEMENS CSA REPORT	SC SOP Instance UID	U	1
(0029,xx10)	SIEMENS CSA ENVELOPE	syngo Report Data	OB	1
(0029,xx11)	SIEMENS CSA ENVELOPE	syngo Report Presentation	OB	1
(0029,xx08)	SIEMENS MEDCOM HEADER	MedCom Header Type	CS	1
(0029,xx09)	SIEMENS MEDCOM HEADER	MedCom Header Version	LO	1
(0029,xx10)	SIEMENS MEDCOM HEADER	MedCom Header Info	OB	1
(0029,xx20)	SIEMENS MEDCOM HEADER	MedCom History Information	OB	1
(0029,xx31)	SIEMENS MEDCOM HEADER	PMTF Information 1	LO	1
(0029,xx32)	SIEMENS MEDCOM HEADER	PMTF Information 2	UL	1
(0029,xx33)	SIEMENS MEDCOM HEADER	PMTF Information 3	UL	1
(0029,xx34)	SIEMENS MEDCOM HEADER	PMTF Information 4	CS	1
(0029,xx35)	SIEMENS MEDCOM HEADER	PMTF Information 5	UL	1
(0029,xx40)	SIEMENS MEDCOM HEADER	Application Header Sequence	SQ	1
(0029,xx41)	SIEMENS MEDCOM HEADER	Application Header Type	CS	1
(0029,xx42)	SIEMENS MEDCOM HEADER	Application Header ID	LO	1
(0029,xx43)	SIEMENS MEDCOM HEADER	Application Header Version	LO	1
(0029,xx44)	SIEMENS MEDCOM HEADER	Application Header Info	OB	1
(0029,xx50)	SIEMENS MEDCOM HEADER	Workflow Control Flags	LO	8
(0029,xx51)	SIEMENS MEDCOM HEADER	Arch. Management Flag Keep Online	CS	1
(0029,xx52)	SIEMENS MEDCOM HEADER	Arch. Mgmt Flag Do Not Archive	CS	1
(0029,xx53)	SIEMENS MEDCOM HEADER	Image Location Status	CS	1
(0029,xx54)	SIEMENS MEDCOM HEADER	Estimated Retrieve Time	DS	1
(0029,xx55)	SIEMENS MEDCOM HEADER	Data Size of Retrieved Images	DS	1
(0029,xx08)	SIEMENS MEDCOM OOG	MedCom OOG Type	CS	1
(0029,xx09)	SIEMENS MEDCOM OOG	MedCom OOG Version	LO	1
(0029,xx10)	SIEMENS MEDCOM OOG	MedCom OOG Info	OB	1
(7FE1,xx10)	SIEMENS CSA NON-IMAGE	CSA Data	OB	1

A.4 Standard Extensions of all SOP Classes

The following tables list the data dictionary of all DICOM IOD attributes where the DICOM standard definitions are extended:

Attribute Name	Tag	Private Creator	Type	Notes
Image Type	(0008,0008)	-	1	see A.4.1 additional Defined Terms: Defined Terms for value 3: OTHER Defined Terms for value 4: CSA 3D EDITOR CSA 3D FLY PATH CSA 3D FLY VRT CSA 3D FUSION CSA AVERAGE CSA BLACK IMAGE CSA RESAMPLED CSA MIP CSA MPR CSA MPR CURVED CSA MPR THICK CSA SSD CSA SUBTRACT CT_SOM4 * ECAT ACF ECAT NORMAL ECAT 3D SINO ECAT 3D SINO FLT SHS *
Patient Position	(0018,5100)	-	2C	see A.4.2 additional Defined Terms for the Magnetom Open: HLS HLP FLS FLP HLDL HLDR FLDL FLDR

All SOP classes may contain additional type 3 attributes which DICOM standard defines in a different DICOM IOD or DICOM SOP class (attributes from Normalized SOP classes).

This is the case for example for

- Rescale Slope (0028,1053)
 - Rescale Intercept (0028,1052)
- which are also used in the MR IOD.

A.4.1 Image Type

The Image Type (0008,0008) attribute identifies important image identification characteristics. These characteristics are:

1. Pixel Data Characteristics:

- is the image an ORIGINAL Image; an image whose pixel values are based on original or source data, or

- is the image a DERIVED Image; an image whose pixel values have been derived in some manner from the pixel value of one or more other images.
 2. Patient Examination Characteristics:
- is the image a PRIMARY Image; an image created as a direct result of the Patient examination, or
- is the image a SECONDARY Image; an image created after the initial Patient examination.
 3. Modality Specific Characteristics (SOP Specific Characteristics).
 4. Implementation specific identifiers; other implementation specific identifiers shall be documented in an implementation's conformance claim.

The Image Type attribute is multi-valued and shall be provided in the following manner:

- Value 1 shall identify the Pixel Data Characteristics; Enumerated Values for the Pixel Data Characteristics are:
 - ORIGINAL = identifies an Original Image
 - DERIVED = identifies a Derived Image
- Value 2 shall identify the Patient Examination Characteristics; Enumerated Values for the Patient Examination Characteristics are:
 - PRIMARY = identifies a Primary Image
 - SECONDARY = identifies a Secondary Image
- Value 3 shall identify any Image IOD specific specialization, the following terms are defined in addition to the DICOM standard definitions:
 - OTHER = is also used for converted non-Axial and non-Localizer CT images
 - MPR = for 3D MPR images
 - PROJECTION IMAGE = for 3D MIP and SSD images
- Value 4 which are implementation specific, the following terms are defined in addition to the DICOM standard definitions:
 - original *syngo* generated data set types:
 - CSA 3D EDITOR = object created by 3D Editor
 - CSA 3D FLY PATH = object created by Fly Through Path
 - CSA 3D FLY VRT = object created by Fly Through Volume Rendering Technique
 - CSA 3D FUSION = object created by Fusion
 - CSA AVERAGE = image was created by Average
 - CSA BLACK IMAGE = SC Image with black pixels, only graphics information is of interest
 - CSA RESAMPLED = derived image created by zooming or panning original image
 - CSA REPORT = *syngo* reporting (documentation of diagnosis)
 - CSA RESULT = *syngo* reporting (postprocessing results)
 - CSA MIP = image created by Maximum Intensity Projection
 - CSA MIP THIN = image created by Maximum Intensity Projection
 - CSA MPR = image created by Multi Planar Reconstruction
 - CSA MPR CURVED = image created by Multi Planar Reconstruction
 - CSA MPR THICK = image created by Multi Planar Reconstruction
 - CSA MPR THIN = image created by Multi Planar Reconstruction
 - CSA SSD = SC Image as Shaded Surface Display
 - CSA SUBTRACT = image was created by Subtraction
 - ECAT ACF = CTI PET Attenuation Correction
 - ECAT NORMAL = CTI PET Normalization
 - ECAT 3D SINO = CTI PET 3D Sinogram Short
 - ECAT 3D SINO FLT = CTI PET 3D Sinogram Float

- Converted images
 - CT_SOM4 NONE = converted SOMARIS image
 - CT_SOM4 CONV = converted SOMARIS Convolution Kernel file
 - CT_SOM4 DART = converted SOMARIS Dental Artificial image
 - CT_SOM4 DEVA = converted SOMARIS Dental Evaluation image
 - CT_SOM4 DGRA = converted SOMARIS Dental Graphics image
 - CT_SOM4 DMEA = converted SOMARIS Dynamic Measurement image
 - CT_SOM4 DPAN = converted SOMARIS Dental Panorama image
 - CT_SOM4 DPAR = converted SOMARIS Dental Paraxial image
 - CT_SOM4 EBT = converted SOMARIS Evolution image
 - CT_SOM4 HIS = converted SOMARIS Histogram Graphics image
 - CT_SOM4 HISC = converted SOMARIS Histogram Graphics image
 - CT_SOM4 MUL = converted SOMARIS Multiscan image
 - CT_SOM4 OEVA = converted SOMARIS Osteo Evaluation image
 - CT_SOM4 OTOM = converted SOMARIS Osteo Tomogram image
 - CT_SOM4 OTOP = converted SOMARIS Osteo Topogram image
 - CT_SOM4 PLOT = converted SOMARIS Plot image
 - CT_SOM4 QUAL = converted SOMARIS Quality image
 - CT_SOM4 R2D = converted SOMARIS 2D Rebuild image
 - CT_SOM4 R3D = converted SOMARIS 3D Rebuild image
 - CT_SOM4 R3DE = converted SOMARIS 3D Rebuild image
 - CT_SOM4 RMAX = converted SOMARIS Maximum Intensity Projection image
 - CT_SOM4 RMIN = converted SOMARIS Minimum Intensity Projection image
 - CT_SOM4 ROT = converted SOMARIS Rotation Mode image
 - CT_SOM4 RRAD = converted SOMARIS Radiographic Projection image
 - CT_SOM4 RVIT = converted SOMARIS Vessel Image Tool image
 - CT_SOM4 RVRT = converted SOMARIS Volumetric Rendering image
 - CT_SOM4 SAVE = converted SOMARIS Evolution Screen Save image
 - CT_SOM4 SCAN = converted SOMARIS Standard Mode image
 - CT_SOM4 SEQ = converted SOMARIS Sequence Mode image
 - CT_SOM4 SER = converted SOMARIS Serial Mode image
 - CT_SOM4 SIN = converted SOMARIS Sinogram image
 - CT_SOM4 SINC = converted SOMARIS Sinogram image
 - CT_SOM4 SPI = converted SOMARIS Spiral Mode image
 - CT_SOM4 STA = converted SOMARIS Static Mode image
 - CT_SOM4 TAB = converted SOMARIS Correction Table image
 - CT_SOM4 TOP = converted SOMARIS Topogram image
 - CT_SOM4 GTOP = converted SOMARIS Topo Graphics image
 - CT_SOM4 PEVG = converted SOMARIS Pulmo Evaluation image
 - CT_SOM4 PEVI = converted SOMARIS Pulmo Evaluation image
 - CT_SOM4 PUL = converted SOMARIS Pulmo Respiration image
 - CT_SOM4 PROT = converted SOMARIS Protocol image
 - CT_SOM4 TEXT = converted SOMARIS Text image
 - CT_SOM4 ICD = converted SOMARIS Interventional Cine image
 - SHS DENT = converted MagicView Dental Tomogram image
 - SHS DPAN = converted MagicView Dental Panorama image
 - SHS DPAR = converted MagicView Dental Paraxial image
 - SHS 3D_CURVED = converted MagicView image
 - SHS 3D_MIP = converted MagicView Maximum Intensity Projection image
 - SHS 3D_MPR = converted MagicView Multi Planar Reconstruction image
 - SHS 3D_SSD = converted MagicView Shaded Surface Display image
 - SHS 3D_VRT = converted MagicView Volumetric Rendering image

A.5 Standard Extensions of NM SOP Class

The following table lists the data dictionary of all DICOM IOD attributes which are encoded in a DICOM standard where the Private Creator Identification is, "Siemens MED NM"

Tag	VR	VM	Value
(0019,00A5)	SS	1-n	Number of repeats per phase
(0019,00A6)	SS	1-n	Cycles per repeat
(0019,00A7)	SL	1-n	Repeat start time
(0019,00A8)	SL	1-n	Repeat stop time
(0019,00A9)	SL	1-n	Effective repeat time
(0019,00AA)	SS	1-n	Acquired cycles per repeat
(0021,0000)	OB	1	ECAT File Menu Header
(0021,0001)	OB	1	ECAT File Subheader
(0033,0000)	FL	n	Flood correction Matrix Det 1 upto SR 2.0
(0033,0001)	FL	n	Flood correction Matrix Det 2 upto SR 2.0
(0033,0024)	FL	1	Backprojection angle head 1
(0033,0025)	FL	1	Backprojection angle head 2
(0033,0028)	SL	1	Number of point sources used for NCO and MHR
(0033,0029)	FL	1	Crystal thickness
(0033,0030)	LO	1	Preset name used for acquisition
(0033,0031)	FL	1	Camera config angle
(0033,0032)	LO	1	Crystal type Startburst or not
(0033,0033)	SL	1	Gantry step for COIN acquisitions
(0033,0034)	FL	1	Bed step for wholebody or Coin acquisitions
(0033,0035)	FL	1	Weight factor table for coincidence acquisitions
(0033,0036)	FL	1	Transaxial acceptance width for coincidence
(0033,0037)	SL	1	Starburst flags
(0033,0038)	FL	1	Pixel scale factor
(0035,0000)	LO	1	Specialized tomo type
(0035,0001)	LO	1	Energy window type
(0035,0002)	SS	1	Start and end row illuminated by wind position
(0035,0003)	LO	1	Blank scan image for profile
(0035,0004)	SS	1	Repeat number of the original dynamic SPECT
(0035,0005)	SS	1	Phase number of the original dynamic SPECT
(0039,0000)	LT	1	Toshiba CBF activity results
(0055,0004)	SS	1	Prompt window width
(0055,0005)	SS	1	Random window width
(0055,007E)	FL	1-n	Collimator thickness
(0055,007F)	FL	1-n	Collimator angular resolution
(0057,0001)	LO	1	e.soft DICOM original image type
(0057,0002)	FL	1	Dose calibration factor
(0057,0003)	LO	1	Units
(0057,0004)	LO	1	Decay correction
(0057,0005)	SL	N	Radio nuclide half life
(0057,0006)	FL	1	Rescale intercept
(0057,0007)	FL	1	Rescale Slope
(0057,0008)	FL	1	Frame reference time
(0057,0009)	SL	1	Number of Radiopharmaceutical information seq
(0057,000A)	FL	1	Decay factor
(0057,000B)	LO	1	Counts source
(0057,000C)	SL	n	Radio Nuclide positron fraction
(7FE3,0014)	OW	1	Minimum pixel in frame
(7FE3,0015)	OW	1	Maximum pixel in frame
7FE3	OW	1	Number of R-Waves in frame

A.6 Standard Extensions of PT SOP Class

The following table lists the data dictionary of all DICOM IOD attributes which are encoded in a DICOM standard where the Private Creator Identification is, "Siemens MED NM"

Tag	VR	VM	Value
(0021,0000)	OB	1	ECAT File Menu Header
(0021,0001)	OB	1	ECAT File Subheader

A.7 DICOM Print SCU – detailed status displays

The following tables document the behavior of the e.soft DICOM Print AE in response to messages received for the printer SOP class and the print job SOP class.

Definitions of camera symbols:

- Idle: Camera is installed and ready; idle icon is displayed.
- Interact: The user has to react in near future, but not immediately.
Example: A camera was low in 8x10 clear sheets: LOW 8x10 CLR was sent by n-event-report.
- Queue Stopped: The user has to react immediately. Either the camera needs immediate interaction or a job has been aborted.
Example: A camera is out of 8x10 clear sheets, or camera is down, or a film job is aborted.

Note: different camera symbols are displayed according to the Printer Status Info.

The Printer Status (Success, Warning, Failure) is not evaluated, since the Printer Status Info is much more detailed and allows a more appropriate reaction of the system.

A.7.1 Common Status Information

"Common Status Info evaluation"

Printer Status Info/ Execution Status Info	Description	Message string visible in 'Status Bar'	Other action for UI/ 'camera symbol'
NORMAL	Camera is ready	Camera is ready	<None>/idle
BAD RECEIVE MGZ	There is a problem with the film receive magazine. Films from the printer cannot be transported into the magazine.	Problem with receive magazine.	<None>/interact
BAD SUPPLY MGZ	There is a problem with the film supply magazine. Films from this magazine cannot be transported into the printer.	Problem with supply magazine.	<None>/interact
CALIBRATING	Printer is performing self calibration, it is expected to be available for normal operation shortly.	Self calibration. Please wait.	<None>/idle
CALIBRATION ERR	An error in the printer calibration has been detected, quality of processed films may not be optimal.	Problem in calibration. Film quality may not be optimal.	<None>/interact
CHECK CHEMISTRY	A problem with the processor chemicals has been detected, quality of processed films may not be optimal.	Problem with chemistry. Film quality may not be optimal.	<None>/interact
CHECK SORTER	There is an error in the film sorter	Error in film sorter.	<None>/interact
CHEMICALS EMPTY	There are no processing chemicals in the processor, films will not be printed and processed until the processor is back to normal.	Camera chemistry empty. Please check.	<None>/interact
CHEMICALS LOW	The chemical level in the processor is low, if not corrected, it will probably shut down soon.	Camera chemistry low. Please check.	<None>/interact
COVER OPEN	One or more printer or processor covers, drawers, doors are open.	Camera cover, drawer or door open.	<None>/interact

Printer Status Info/ Execution Status Info	Description	Message string visible in 'Status Bar'	Other action for UI/ 'camera symbol'
ELEC CONFIG ERR	Printer configured improperly for this job.	Camera configured improperly for this job. Queue stopped.	Queue for this camera will be STOPPED/ Queue stopped
ELEC DOWN	Printer is not operating due to some unspecified electrical hardware problem.	Camera electrical hardware Problem.	<None>/interact
ELEC SW ERROR	Printer not operating for some unspecified software error.	Camera software problem. Queue stopped.	Queue for this camera will be STOPPED/ Queue stopped
EMPTY 8x10	The 8x10 inch film supply magazine is empty.	8x10 film supply empty.	<None>/interact
EMPTY 8x10 BLUE	The 8x10 inch blue film supply magazine is empty.	8x10 blue film supply empty.	<None>/interact
EMPTY 8x10 CLR	The 8x10 inch clear film supply magazine is empty.	8x10 clear film supply empty.	<None>/interact
EMPTY 8x10 PAPR	The 8x10 inch paper supply magazine is empty.	8x10 paper supply empty.	<None>/interact
EMPTY 10x12	The 10x12 inch film supply magazine is empty.	10x12 film supply empty.	<None>/interact
EMPTY 10x12 BLUE	The 10x12 inch blue film supply magazine is empty.	10x12 blue film supply empty.	<None>/interact
EMPTY 10x12 CLR	The 10x12 inch clear film supply magazine is empty.	10x12 clear film supply empty.	<None>/interact
EMPTY 10x12 PAPR	The 10x12 inch paper supply magazine is empty.	10x12 paper supply empty.	<None>/interact
EMPTY 10x14	The 10x14 inch film supply magazine is empty.	10x14 film supply empty.	<None>/interact
EMPTY 10x14 BLUE	The 10x14 inch blue film supply magazine is empty.	10x14 blue film supply empty.	<None>/interact
EMPTY 10x14 CLR	The 10x14 inch clear film supply magazine is empty.	10x14 clear film supply empty.	<None>/interact
EMPTY 10x14 PAPR	The 10x14 inch paper supply magazine is empty.	10x14 paper supply empty.	<None>/interact
EMPTY 11x14	The 11x14 inch film supply magazine is empty.	11x14 film supply empty.	<None>/interact
EMPTY 11x14 BLUE	The 11x14 inch blue film supply magazine is empty.	11x14 blue film supply empty.	<None>/interact
EMPTY 11x14 CLR	The 11x14 inch clear film supply magazine is empty.	11x14 clear film supply empty.	<None>/interact
EMPTY 11x14 PAPR	The 11x14 inch paper supply magazine is empty.	11x14 paper supply empty.	<None>/interact
EMPTY 14x14	The 14x14 inch film supply magazine is empty.	14x14 film supply empty.	<None>/interact
EMPTY 14x14 BLUE	The 14x14 inch blue film supply magazine is empty.	14x14 blue film supply empty.	<None>/interact
EMPTY 14x14 CLR	The 14x14 inch clear film supply magazine is empty.	14x14 clear film supply empty.	<None>/interact
EMPTY 14x14 PAPR	The 14x14 inch paper supply magazine is empty.	14x14 paper supply empty.	<None>/interact
EMPTY 14x17	The 14x17 inch film supply magazine is empty.	14x17 film supply empty.	<None>/interact
EMPTY 14x17 BLUE	The 14x17 inch blue film supply magazine is empty.	14x17 blue film supply empty.	<None>/interact
EMPTY 14x17 CLR	The 14x17 inch clear film supply magazine is empty.	14x17 clear film supply empty.	<None>/interact
EMPTY 14x17 PAPR	The 14x17 inch paper supply magazine is empty.	14x17 paper supply empty.	<None>/interact
EMPTY 24x24	The 24x24 inch film supply magazine is empty.	24x24 film supply empty.	<None>/interact
EMPTY 24x24 BLUE	The 24x24 inch blue film supply magazine is empty.	24x24 blue film supply empty.	<None>/interact
EMPTY 24x24 CLR	The 24x24 inch clear film supply magazine is empty.	24x24 clear film supply empty.	<None>/interact
EMPTY 24x24 PAPR	The 24x24 inch paper supply magazine is empty.	24x24 paper supply empty.	<None>/interact
EMPTY 24x30	The 24x30 inch film supply magazine is empty.	24x30 film supply empty.	<None>/interact
EMPTY 24x30 BLUE	The 24x30 inch blue film supply magazine is empty.	24x30 blue film supply empty.	<None>/interact

Printer Status Info/ Execution Status Info	Description	Message string visible in 'Status Bar'	Other action for UI/ 'camera symbol'
EMPTY 24x30 CLR	The 24x30 inch clear film supply magazine is empty.	24x30 clear film supply empty.	<None>/interact
EMPTY 24x30 PAPER	The 24x30 inch paper supply magazine is empty.	24x30 paper supply empty.	<None>/interact
EMPTY A4 PAPER	The A4 paper supply magazine is empty.	A4 paper supply empty	<None>/interact
EMPTY A4 TRANS	The A4 transparency supply magazine is empty.	A4 transparency supply empty.	<None>/interact
EXPOSURE FAILURE	The exposure device has failed due to some unspecified reason.	Exposure device has failed.	<None>/interact
FILM JAM	A film transport error has occurred and a film is jammed in the printer or processor.	Film jam.	<None>/interact
FILM TRANSP ERR	There is a malfunction with the film transport, there may or may not be a film jam.	Film transport problem .	<None>/interact
FINISHER EMPTY	The finisher is empty.	Finisher is empty.	<None>/interact
FINISHER ERROR	The finisher is not operating due to some unspecified reason	Finisher problem.	<None>/interact
FINISHER LOW	The finisher is low on supplies.	Finisher low.	<None>/interact
LOW 8x10	The 8x10 inch film supply magazine is low.	8x10 film supply low.	<None>/interact
LOW 8x10 BLUE	The 8x10 inch blue film supply magazine is low.	8x10 blue film supply low.	<None>/interact
LOW 8x10 CLR	The 8x10 inch clear film supply magazine is low.	8x10 clear film supply low.	<None>/interact
LOW 8x10 PAPER	The 8x10 inch paper supply magazine is low.	8x10 paper supply low.	<None>/interact
LOW 10x12	The 10x12 inch film supply magazine is low.	10x12 film supply low.	<None>/interact
LOW 10x12 BLUE	The 10x12 inch blue film supply magazine is low.	10x12 blue film supply low.	<None>/interact
LOW 10x12 CLR	The 10x12 inch clear film supply magazine is low.	10x12 clear film supply low.	<None>/interact
LOW 10x12 PAPER	The 10x12 inch paper supply magazine is low.	10x12 paper supply low.	<None>/interact
LOW 10x14	The 10x14 inch film supply magazine is low.	10x14 film supply low.	<None>/interact
LOW 10x14 BLUE	The 10x14 inch blue film supply magazine is low.	10x14 blue film supply low.	<None>/interact
LOW 10x14 CLR	The 10x14 inch clear film supply magazine is low.	10x14 clear film supply low.	<None>/interact
LOW 10x14 PAPER	The 10x14 inch paper supply magazine is low.	10x14 paper supply low.	<None>/interact
LOW 11x14	The 11x14 inch film supply magazine is low.	11x14 film supply low.	<None>/interact
LOW 11x14 BLUE	The 11x14 inch blue film supply magazine is low.	11x14 blue film supply low.	<None>/interact
LOW 11x14 CLR	The 11x14 inch clear film supply magazine is low.	11x14 clear film supply low.	<None>/interact
LOW 11x14 PAPER	The 11x14 inch paper supply magazine is low.	11x14 paper supply low.	<None>/interact
LOW 14x14	The 14x14 inch film supply magazine is low.	14x14 film supply low.	<None>/interact
LOW 14x14 BLUE	The 14x14 inch blue film supply magazine is low.	14x14 blue film supply low.	<None>/interact
LOW 14x14 CLR	The 14x14 inch clear film supply magazine is low.	14x14 clear film supply low.	<None>/interact
LOW 14x14 PAPER	The 14x14 inch paper supply magazine is low.	14x14 paper supply low.	<None>/interact
LOW 14x17	The 14x17 inch film supply magazine is low.	14x17 film supply low.	<None>/interact
LOW 14x17 BLUE	The 14x17 inch blue film supply magazine is low.	14x17 blue film supply low.	<None>/interact
LOW 14x17 CLR	The 14x17 inch clear film supply magazine is low.	14x17 clear film supply low.	<None>/interact
LOW 14x17 PAPER	The 14x17 inch paper supply magazine is low.	14x17 paper supply low.	<None>/interact
LOW 24x24	The 24x24 inch film supply magazine is low.	24x24 film supply low.	<None>/interact

Printer Status Info/ Execution Status Info	Description	Message string visible in 'Status Bar'	Other action for UI/ 'camera symbol'
LOW 24x24 BLUE	The 24x24 inch blue film supply magazine is low.	24x24 blue film supply low.	<None>/interact
LOW 24x24 CLR	The 24x24 inch clear film supply magazine is low.	24x24 clear film supply low.	<None>/interact
LOW 24x24 PAPER	The 24x24 inch paper supply magazine is low.	24x24 paper supply low.	<None>/interact
LOW 24x30	The 24x30 inch film supply magazine is low.	24x30 film supply low.	<None>/interact
LOW 24x30 BLUE	The 24x30 inch blue film supply magazine is low.	24x30 blue film supply low.	<None>/interact
LOW 24x30 CLR	The 24x30 inch clear film supply magazine is low.	24x30 clear film supply low.	<None>/interact
LOW 24x30 PAPER	The 24x30 inch paper supply magazine is low.	24x30 paper supply low.	<None>/interact
LOW A4 PAPER	The A4 paper supply magazine is low.	A4 paper supply low.	<None>/interact
LOW A4 TRANS	The A4 transparency supply magazine is low..	A4 transparency supply low.	<None>/interact
NO RECEIVE MGZ	The film receive magazine is not available.	Film receiver not available.	<None>/interact
NO RIBBON	The ribbon cartridge needs to be replaced.	Replace ribbon cartridge.	<None>/interact
NO SUPPLY MGZ	The film supply magazine is not available.	Film supply not available.	<None>/interact
CHECK PRINTER	The printer is not ready at this time, operator intervention is required to make the printer available.	Check camera.	<None>/interact
CHECK PROC	The processor is not ready at this time, operator intervention is required to make the printer available.	Check processor.	<None>/interact
PRINTER DOWN	The printer is not operating due to some unspecified reason.	Camera down.	<None>/interact
PRINTER INIT	The printer is not ready at this time, it is expected to become available without intervention. For example, it may be in a normal warm-up state.	Camera initializing.	<None>/Idle
PRINTER OFFLINE	The printer has been disabled by an operator or service person.	Camera off-line.	<None>/interact
PROC DOWN	The processor is not operating due to some unspecified reason.	Processor down.	<None>/interact
PROC INIT	The processor is not ready at this time, it is expected to become available without intervention. For example, it may be in a normal warm-up state.	Processor initializing.	<None>/Idle
PROC OVERFLOW FL	Processor chemicals are approaching the overflow full mark.	Processor chemicals near overflow.	<None>/interact
PROC OVERFLOW HI	Processor chemicals have reached the overflow full mark.	Processor chemicals overflow.	<None>/interact
QUEUED	Print job in Queue	-	<None>/Idle
RECEIVER FULL	The film receive magazine is full.	Receiver full.	<None>/interact
REQ MED NOT INST	The requested film, paper, or other media supply magazine is installed in the printer, but may be available with operator intervention.	Install media supply.	<None>/interact
REQ MED NOT AVAI	The requested film, paper, or other media requested is not available on this printer.	Media supply not available on this camera. Queue stopped. Change camera.	Queue for this camera will be STOPPED/ Queue stopped
RIBBON ERROR	There is an unspecified problem with the print ribbon.	Error with print ribbon.	<None>/interact
SUPPLY EMPTY	The printer is out of film.	Camera out of film.	<None>/interact
SUPPLY LOW	The film supply is low.	Film supply low.	<None>/interact
UNKNOWN	There is an unspecified problem.	Unspecified problem with camera.	<None>/interact

A.7.2 Additional Status Information – AGFA printers

“Additional Agfa printer Status Info evaluation”

Printer Status Info/ Execution Status Info	Description	Message string visible in 'Status Bar'	Other action for UI/ 'camera symbol'
WARMING UP	Printer is in the warm-up stage. Spooling of print jobs to disk is still possible.	Camera is warming up.	<None>/idle
OFFLINE	OFFLINE Printer is switched off-line. Spooling of print jobs to disk is still possible.	Camera is switched off-line.	<None>/interact
NONE	General printer warning, no specific information is available. Spooling of print jobs to disk is still possible.	-	<None>/idle

A.7.3 Additional Status Information – Kodak PACS Link (formerly Imation)

“Additional Kodak PACS Link (Imation) printer Status Info evaluation”

Printer Status Info/ Execution Status Info	Description	Message string visible in 'Status Bar'	Other action for UI/ 'camera symbol'
SUPPLY MGZ ERR	The supply magazine has an error.	Film supply has an error.	<None>/interact

A.7.4 Additional Status Information – Kodak 1901

“Additional Kodak 190 printer Status Info evaluation”

Printer Status Info/ Execution Status Info	Description	Message string visible in 'Status Bar'	Other action for UI/ 'camera symbol'
PRINTER STOPPED	The printer has stopped.	Camera has stopped.	<None>/interact
FATAL ERROR	Fatal Error.	Fatal Error. Queue stopped.	Queue for this camera will be STOPPED/ Queue stopped

A.7.5 Additional Status Information – Kodak 2180/1120

“Additional Kodak 2180/1120 printer Status Info evaluation”

Printer Status Info/ Execution Status Info	Description	Message string visible in 'Status Bar'	Other action for UI/ 'camera symbol'
PRINTER NOT RDY	Printer not ready.	Camera not ready..	<None>/interact
CHECK PROCESSOR	Check processor.	Check processor.	<None>/interact
NO TONER	No toner.	No toner.	<None>/interact
FATAL	Fatal Error.	Fatal Error. Queue stopped.	Queue for this camera will be STOPPED/ Queue stopped

A.7.6 Additional Status Information – Codonics

“Additional Codonics printer Status Info evaluation”

Printer Status Info/ Execution Status Info	Description	Message string visible in 'Status Bar'	Other action for UI/ 'camera symbol'
STANDARD	Printer is ready.	Camera is ready.	<None>/Normal
LOAD A-SIZE	Load A-Size media.	Load A-Size media.	<None>/interact
LOAD A-DVPAPER	Load A-Size black and white paper.	Load A-Size black and white paper.	<None>/interact
LOAD A-CVPAPER	Load A-Size color paper.	Load A-Size color paper.	<None>/interact
LOAD A-CVTRANS	Load A-Size transparencies.	Load A-Size transparencies.	<None>/interact

Printer Status Info/ Execution Status Info	Description	Message string visible in 'Status Bar'	Other action for UI/ 'camera symbol'
LOAD A4-SIZE	Load A4-Size media.	Load A4-Size media.	<None>/interact
LOAD A4-DVPAPER	Load A4-Size black and white paper.	Load A4-Size black and white paper.	<None>/interact
LOAD A4-CVPAPER	Load A4-Size color paper.	Load A4-Size color paper.	<None>/interact
LOAD A4-CVTRANS	Load A4-Size transparencies.	Load A4-Size transparencies.	<None>/interact
LOAD LA-SIZE	Load LA-Size media.	Load LA-Size media.	<None>/interact
LOAD LA-DVPAPER	Load LA-Size black and white paper.	Load LA-Size black and white paper.	<None>/interact
LOAD LA-CVPAPER	Load LA-Size color paper.	Load LA-Size color paper.	<None>/interact
LOAD LA-CVTRANS	Load LA-Size transparencies.	Load LA-Size transparencies.	<None>/interact
LOAD LA4-SIZE	Load LA4-Size media.	Load LA4-Size media.	<None>/interact
LOAD LA4-DVPAPER	Load LA4-Size black and white paper.	Load LA4-Size black and white paper.	<None>/interact
LOAD LA4-CVPAPER	Load LA4-Size color paper.	Load LA4-Size color paper.	<None>/interact
LOAD LA4-CVTRANS	Load LA4-Size transparencies.	Load LA4-Size transparencies.	<None>/interact
LOAD XLA-SIZE	Load XLA-Size media.	Load XLA-Size media.	<None>/interact
LOAD XLA-DVPAPER	Load XLA-Size black and white paper.	Load XLA-Size black and white paper.	<None>/interact
LOAD XLA-CVPAPER	Load XLA-Size color paper.	Load XLA-Size color paper.	<None>/interact
LOAD XLA-CVTRANS	Load XLA-Size transparencies.	Load XLA-Size transparencies.	<None>/interact
LOAD XLA4-SIZE	Load XLA4-Size media.	Load XLA4-Size media.	<None>/interact
LOAD XLA4-DVPAPER	Load XLA4-Size black and white paper.	Load XLA4-Size black and white paper.	<None>/interact
LOAD XLA4-CVPAPER	Load XLA4-Size color paper.	Load XLA4-Size color paper.	<None>/interact
LOAD XLA4-CVTRANS	Load XLA4-Size transparencies.	Load XLA4-Size transparencies.	<None>/interact
LOAD XLW-SIZE	Load XLW-Size media.	Load XLW-Size media.	<None>/interact
LOAD XLW-DVPAPER	Load XLW-Size black and white paper.	Load XLW-Size black and white paper.	<None>/interact
LOAD XLW-CVPAPER	Load XLW-Size color paper.	Load XLW-Size color paper.	<None>/interact
LOAD 8X10-SIZE	Load 8x10 media.	Load 8x10 media.	<None>/interact
LOAD 8X10-DVFILM	Load XLW-Size black and white film.	Load XLW-Size black and white film.	<None>/interact
SUPPLY MISSING	The film supply magazine specified for this job is not available.	Film supply not available.	<None>/interact
RIBBON MISSING	Ribbon is missing.	Ribbon is missing.	<None>/interact
RIBBON EMPTY	Ribbon is empty.	Ribbon is empty.	<None>/interact
TOP COVER OPEN	Top cover of printer is open.	Top cover of camera is open.	<None>/interact

A.7.7 Additional DICOM Execution Status Information

"Additional DICOM Execution Status Info evaluation"

Printer Status Info/ Execution Status Info	Description	Message string visible in 'Status Bar'	Other action for UI/ 'camera symbol'
INVALID PAGE DES	The specified page layout cannot be printed or other page description errors have been detected.	Film Job cannot be printed on this camera. Queue stopped. Please redirect film job.	Queue for this camera will be STOPPED/ Queue stopped
INSUFFICIENT MEMORY	There is not enough memory available to complete this job.	Not enough memory available in camera. Queue stopped. Please continue queue or change camera.	Queue for this camera will be STOPPED/ Queue stopped

Printer Status Info/ Execution Status Info	Description	Message string visible in 'Status Bar'	Other action for UI/ 'camera symbol'
NONE	General printer warning, no specific information is available. Spooling of print jobs to disk is still possible.	-	<None>/Idle

Order No. **A91004-M2300-M112-03-7600**
Printed in the U.S.A.
PA05041