

SIENET MagicView 1000 VB33A

HS

DICOM Conformance Statement

Rev. 6.0

20-Jul-2001

Copyright by SIEMENS AG Medical Solutions, Health Services

Author		Approved by	
Name/Dept.:	Name/Dept.:
Date:	Date:
Signature:	Signature:

Copyright © Siemens AG Medical Solutions, Health Services, 2001.
All rights reserved. For internal use only.
Alle Rechte vorbehalten. Nur für internen Gebrauch.

Siemens AG Medical Solutions, Health Services
Henkestr. 127, D-91052 Erlangen

Table of Contents

Table of Contents	3
List of Figures	6
List of Tables	7
0 Introduction	8
0.1 Purpose	8
0.2 Definitions, Acronyms and Abbreviations	8
0.3 References	8
1 Implementation Model	9
1.1 Application Data Flow Diagram	9
1.2 Functional Definitions of Application Entities	11
1.3 Sequencing of Real World Activities	12
2 Application Entity Specifications	13
2.1 Association Establishment Policies	14
2.1.1 General	14
2.1.1.1 Number of Associations	14
2.1.1.2 Asynchronous Nature	15
2.1.1.3 Implementation Identifying Information	15
2.2 Association Initiation Policy	15
2.2.1 Real-World Activity - Send Image Objects to a Remote Node	15
2.2.1.1 Associated Real-World Activity - Send Image Objects to a Remote Node	15
2.2.1.2 Proposed Presentation Contexts	16
2.2.1.3 SOP Specific Conformance Statement	21
2.2.1.4 Images resulting from 3D postprocessing	22
2.2.1.5 Images resulting from Image Composition	23
2.2.2 Real-World Activity - Query the Image Database of a remote node	24
2.2.2.1 Associated Real-World Activity - Query the Image Database of a Remote Node	24
2.2.2.2 Proposed Presentation Contexts	24
2.2.2.3 SOP Specific Conformance Statement	25
2.2.2.3.1 Patient Root C-Find SOP Class Specific Conformance Statement	25
2.2.2.3.2 Study Root C-Find SOP Class Specific Conformance Statement	26
2.2.2.3.3 Patient/Study Only C-Find SOP Class Specific Conformance Statement	27
2.2.3 Real-World Activity - Retrieve Image Objects from a Remote Node	27
2.2.3.1 Associated Real-World Activity - Retrieve Image Objects from a Remote Node	27
2.2.3.2 Proposed Presentation Contexts	28
2.2.3.3 SOP Specific Conformance Statement	28

2.2.4	Real-World Activity - Send Print Request to a Remote Node	29
2.2.4.1	Associated Real-World Activity - Send Print Request to a Remote Node 29	
2.2.4.2	Basic Film Session SOP Class	30
2.2.4.3	Basic Film Box SOP Class	30
2.2.4.4	Basic Grayscale Image Box SOP Class	31
2.2.4.5	Printer SOP Class	31
2.2.4.6	SOP Specific Conformance Statement	32
2.3	Association Acceptance Policy	32
2.3.1	Real-World Activity - Receive Echo	32
2.3.1.1	Associated Real-World Activity - respond to echo request.	32
2.3.1.2	Accepted Presentation Contexts.	32
2.3.1.3	SOP Specific Conformance to the Verification SOP Class	33
2.3.2	Real-World Activity - Receive Image Objects from a Remote Node	33
2.3.2.1	Associated Real-World Activity -Receive Image Objects from a Remote Node	33
2.3.2.2	Accepted Presentation Contexts.	33
2.3.2.3	SOP Specific Conformance Statement	38
2.3.2.4	Restrictions for 3D postprocessing	41
2.3.2.5	Restrictions for Image Composition	42
2.3.3	Real-World Activity - Receive Query Request from a Remote Node	43
2.3.3.1	Associated Real-World Activity - respond to find request	43
2.3.3.2	Accepted Presentation Contexts.	43
2.3.3.3	SOP Specific Conformance Statement	44
2.3.3.3.1	Patient Root C-Find SOP Class Specific Conformance Statement	45
2.3.3.3.2	Study Root C-Find SOP Class Specific Conformance Statement	46
2.3.3.3.3	Patient/Study Only C-Find SOP Class Specific Conformance State- ment	47
2.3.4	Real-World Activity - Receive Transfer Request from a Remote Node	48
2.3.4.1	Associated Real-World Activity - initiate image transfer.	48
2.3.4.2	Accepted Presentation Contexts.	48
2.3.4.3	SOP Specific Conformance statement for SOP class C-Store	48
2.3.5	Real-World Activity - Receive Storage Commitment Request from a Remote Node	49
2.3.5.1	Associated Real-World Activity - Response to Storage Commitment Re- quest	49
2.3.5.2	Accepted presentation Contexts.	49
2.3.5.3	SOP specific Conformance Statement for SOP Class Storage Commitment Push Model SCP	49
2.3.5.3.1	Operations	49
2.3.5.3.2	Notifications.	50
2.3.6	Presentation Context Acceptance Criterion.	50
2.3.7	Transfer Syntax Selection Policies	50
3	Communication Profiles.	51
3.1	Supported Communication Stacks	51
3.1.1	OSI Stack	51

Copyright © Siemens AG Medical Solutions, Health Services, 2001.
 All rights reserved. For internal use only.
 Alle Rechte vorbehalten. Nur für internen Gebrauch.
 Siemens AG Medical Solutions, Health Services
 Henkestr. 127, D-91052 Erlangen

3.1.2	TCP/IP Stack	51
3.1.2.1	Physical Media Support	51
3.1.3	Point-to-Point Stack	51
4	Extensions/Privatizations/Specializations	52
4.1	Standard Extended/ Specialized/Private SOPs	52
4.2	Private Transfer Syntaxes	52
5	Configuration	53
5.1	AE Title / Presentation Address Mapping.	53
5.2	Configurable Parameters	53
6	Support of Extended Character Sets.	55
Index	56

List of Figures

Figure 1: Application Data Flow Diagram.....10
Figure 2: Application Data Flow Diagram.....11

Copyright © Siemens AG Medical Solutions, Health Services, 2001.
All rights reserved. For internal use only.
Alle Rechte vorbehalten. Nur für internen Gebrauch.

Siemens AG Medical Solutions, Health Services
Henkestr. 127, D-91052 Erlangen

List of Tables

Table 1:	Send SCU Presentation Contexts of MagicView	17
Table 2:	Modality and SOP Class UID of 3D result images	22
Table 3:	Pixel formats of 3D result images	22
Table 4:	Image Type (0008/0008), value 4 of 3D result images	23
Table 5:	SOP Class UID of Composed Images	23
Table 6:	Query SCU Presentation Contexts of MagicView 1000	24
Table 7:	Supported Patient level attributes	25
Table 8:	Supported Study level attributes	25
Table 9:	Supported Series level attributes	25
Table 10:	Supported Image level attributes	26
Table 11:	Supported Study level attributes	26
Table 12:	C-Move SCU Presentation Contexts of MagicView 1000	28
Table 13:	MagicView 1000 Print Management SCU Presentation Contexts of	29
Table 14:	Supported N_CREATE attributes	30
Table 15:	Supported N_CREATE attributes	30
Table 16:	Supported N_SET attributes	31
Table 17:	Supported N-GET attributes	31
Table 18:	Echo SCP Presentation Contexts of MagicView 1000	33
Table 19:	Send SCP Presentation Contexts of MagicView 1000	34
Table 20:	Pixel formats.....	40
Table 21:	Overlay Attributes	40
Table 22:	Supported modalities for 3D postprocessing.....	41
Table 23:	Supported pixel formats for 3D postprocessing	41
Table 24:	Attributes for 3D postprocessing.....	41
Table 25:	Supported SOP Classes for Image Composition	42
Table 26:	Supported modalities for Image Composition.....	42
Table 28:	Query SCP Presentation Contexts of MagicView 1000	43
Table 27:	Supported pixel formats for Image Composition	43
Table 29:	Supported Patient level attributes	45
Table 30:	Supported Study level attributes	45
Table 31:	Supported Series level attributes	45
Table 32:	Supported Image level attributes	46
Table 33:	Supported Study level attributes	46
Table 34:	Retrieve SCP Presentation Contexts of MagicView 1000	48
Table 35:	Storage Commitment Push Model SCP Presentation Contexts of MagicView 1000	49

0 Introduction

0.1 Purpose

This DICOM Conformance Statement is written according to part PS 3.2 of [1].

This conformance statement describes the DICOM Interface of the Siemens implementation of a Medical Imaging Workstation (SIENET MagicView 1000 VB33A) .

The SIENET MagicView DICOM Interface acts as a Service Class Provider (SCP) for Storage Service Class, Storage Commitment Service Class, Verification Service Class and Query/Retrieve Service Class. The SIENET MagicView DICOM Interface acts as a service class user (SCU) for Storage Service Class, Query Retrieve Service Class and Print Management Service Class.

0.2 Definitions, Acronyms and Abbreviations

ACR	American College of Radiology
AE	DICOM Application Entity
DBP	DICOM Basic Print User
DNES	DICOM N-Event Server
DQRY	DICOM Query Provider
DQUS	DICOM Query User
DRCV	DICOM Receiver
Folder	Siemens specific name for a set of (ACR-NEMA/SPI) images, corresponds to a DICOM Study Component
FOS	Folder Sender
IOD	DICOM Information Object Definition
NEMA	National Electrical Manufacturers Association
PACSnet	Siemens proprietary implementation of the SPI Standard
PDU	Protocol Data Unit
PLA	Pacsnet Logical Address (to identify an application on a PACSnet node)
SCU	DICOM Service Class User (client using this DICOM service)
SCP	DICOM Service Class Provider (server providing this service)
SOP	Service/Object Pair
UID	Unique Identifier, string unique in the whole network

0.3 References

- [1] Digital Imaging and Communications in Medicine (DICOM), NEMA PS 3.1-14

1 Implementation Model

Siemens MagicView DICOM Interface is implemented to support DICOM Application Entities (AE) as a SCP which receive associations (Verification, Storage, Storage Commitment and Query/Retrieve) from remote Application Entities.

Siemens MagicView DICOM Interface originates associations for Storage, Query/Retrieve and Print of DICOM Composite Information Objects in Remote Application Entities.

1.1 Application Data Flow Diagram

DRCV (DICOM Receiver for DICOM Image Storage), FOS (Folder Sender for Image Storage), DQUS (DICOM Query/Retrieve User) DQRY (DICOM Query/ Retrieve Provider), DNES (DICOM Storage Commitment Provider) and DBP (DICOM Basic Print User) are applications to handle the DICOM communication for SIENET MagicView.

These applications are started automatically and will be invoked automatically via network or via the integrated SIENET MagicView user-interface.

- A remote Application Entity (AE) initiates an association for the DICOM Storage Service Class to the AE of DRCV. Upon acceptance of the association by DRCV the remote AE transmits the DICOM Information Objects to DRCV. After an object is received, DRCV initiates the transfer of the DICOM objects to the MagicView image database.
- A remote Application Entity (AE) initiates an association for the DICOM Storage Commitment Service Class to the AE of the DNES. Upon acceptance of the association by DNES the remote AE transmits the DICOM Storage Commitment request. DNES queries the database for the existence of the referenced SOP Instances and returns a success status in case all SOP Instances have been successfully stored. This will be done via the same or a new association.
- FOS initiates associations for DICOM Storage Service Class to remote AEs. For each folder being sent to a remote DICOM node a new association to the corresponding remote DICOM AE is initiated. The DICOM objects are sent via that open association.
- A remote Application Entity (AE) initiates an association for the DICOM Query/ Retrieve Service Class to the AE of DQRY. Upon acceptance of the association by DQRY the remote AE transmits DICOM Query / Retrieve Requests to DQRY.
 - In case of a C-Find Request the DQRY queries the image database of MagicView and generates a response for each match. The responses are sent back to the remote AE via DICOM Query Responses.
 - In case of a C-Move Request the DQRY queries the image database of MagicView and initiates a Storage Request for each match. A final Retrieve response is sent back to the remote AE.

Figure 1: Application Data Flow Diagram

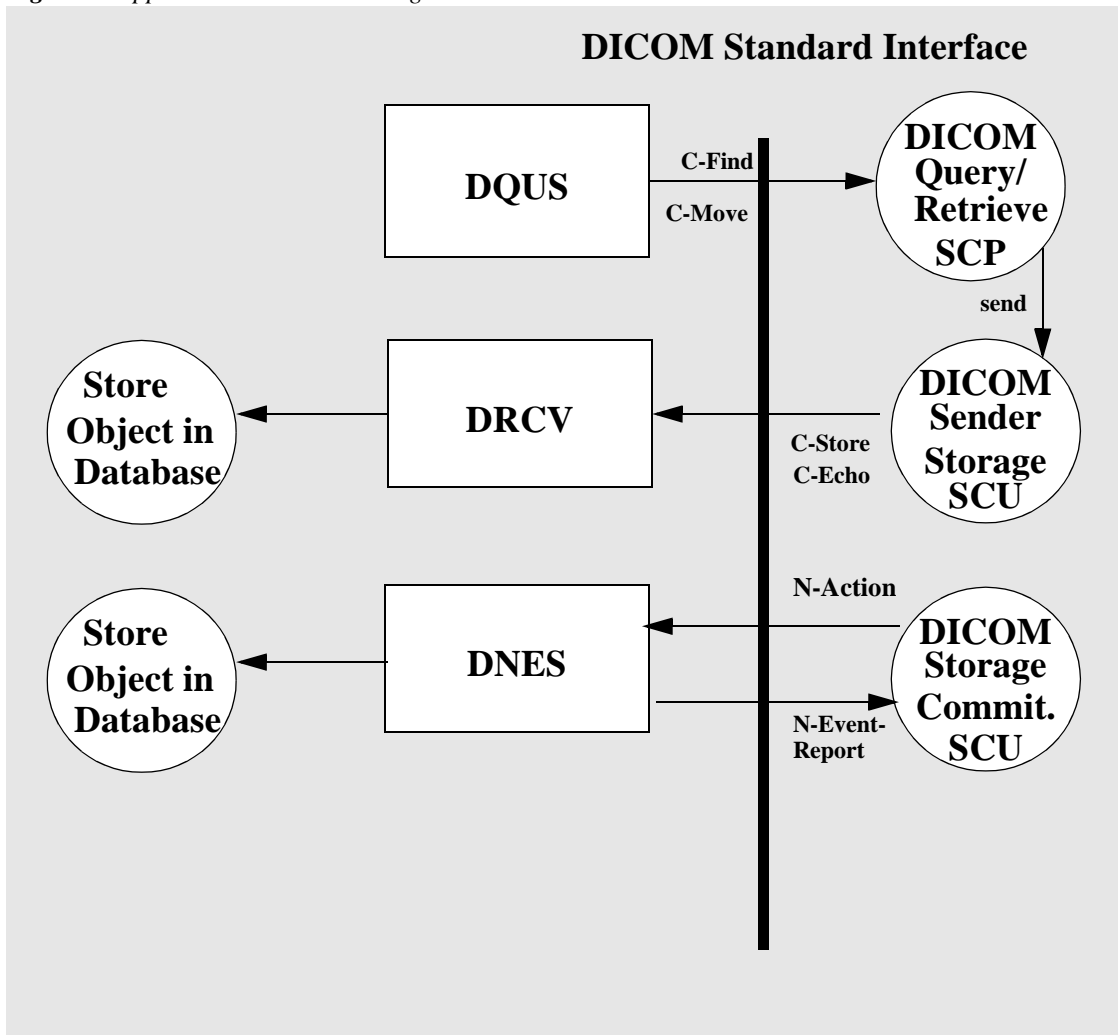

Copyright © Siemens AG Medical Solutions, Health Services, 2001.
All rights reserved. For internal use only.
Alle Rechte vorbehalten. Nur für internen Gebrauch.

Siemens AG Medical Solutions, Health Services
Henkestr. 127, D-91052 Erlangen

Figure 2: Application Data Flow Diagram

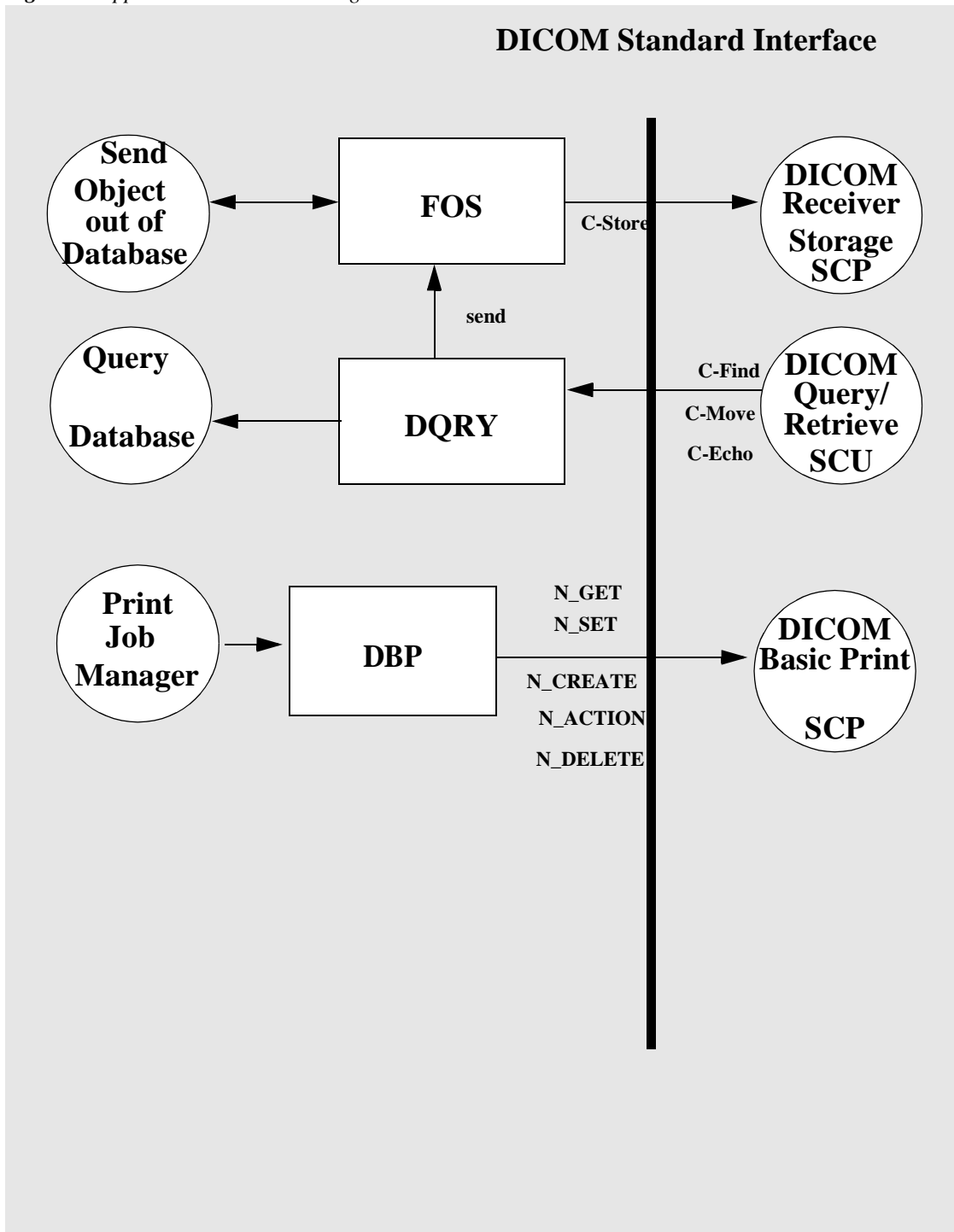

Copyright © Siemens AG Medical Solutions, Health Services, 2001.
 All rights reserved. For internal use only.
 Alle Rechte vorbehalten. Nur für internen Gebrauch.

Siemens AG Medical Solutions, Health Services
 Henkestr. 127, D-91052 Erlangen

1.2 Functional Definitions of Application Entities

All components of the Siemens DICOM Interface (including DRCV, FOS, DQRY, DNES, DQUS, DBP) operate as background daemon processes. They are started automatically during system startup and will remain active until shutdown.

- DRCV acting as a SCP is waiting for association requests from a remote DICOM client. A remote Application Entity (AE) initiates an association for the DICOM Storage Service Class to the AE of DRCV. Upon acceptance of the association by DRCV the remote AE transmits the DICOM Information Objects to DRCV. After an object is received, DRCV initiates the transfer of the DICOM objects to the MagicView image database.
- FOS acting as a SCU waits for requests from other local daemon processes (i.e. a new folder coming in via PACSnet) or for requests from the workstation's user. When a request is received, FOS initiates an association with a remote Application Entity. For each folder being sent to a remote DICOM node a new association to the corresponding remote DICOM AE is initiated. The DICOM objects are sent via that open association.
- DNES acting as a SCP waits for Storage Commitment requests from a remote DICOM Application Entity. As a result DNES sends a N-EVENT_REPORT about success or failure to the Application Entity which issued the Storage Commitment request.
- DBP acting as a SCU waits for print requests from the workstation's user. DBP initiates an association with a remote Application Entity and sends DICOM Basic Print Requests
- DQRY acting as a SCP waits for association requests from a remote DICOM client. A remote Application Entity (AE) initiates an association for the DICOM Query/ Retrieve Service Class to the AE of DQRY. Upon acceptance of the association by DQRY the remote AE transmits DICOM Query / Retrieve Requests to DQRY.
 - In case of a C-Find Request, the DQRY queries the image database of MagicView and generates a response for each match. The responses are sent back to the remote AE via DICOM Query Responses.
 - In case of a C-Move Request, the DQRY queries the image database of MagicView and initiates a Storage Request for each match. A final Retrieve response is sent back to the remote AE.
- DQUS acting as a SCU waits for requests from the workstation's user. When a request is received, DQUS initiates an association with a remote Application Entity and generates a C_FIND Request. The responses are displayed. After folder selection from the user, DQUS initiates an association with the remote Retrieve AET. The destination AE is always DRCV.

1.3 Sequencing of Real World Activities

not applicable.

2 Application Entity Specifications

Each process provides one Application Entity. There are Application Entities of FOS, DRCV, DQRY, DNES, DQUS and DBP.

The Siemens MagicView provides Standard Conformance to the following DICOM Storage SOP Classes as an SCU and SCP:

Storage SOP Classes as an SCU and SCP for:

- CR (Computed Radiography) Image Storage
- CT Image Storage
- Ultrasound Multi-frame Image Storage
- Ultrasound Multi-frame Image Storage - Retired
- Ultrasound Image Storage
- Ultrasound Image Storage - Retired
- MR Image Storage
- SC Image Storage
- NM Image Storage
- X-Ray Radiofluoroscopic Image Storage
- X-Ray Angiographic Image Storage
- RT Image Storage
- PET Image Storage
- Digital X-Ray Image Storage For Presentation
- Digital X-Ray Image Storage For Processing
- Digital Intra-Oral X-Ray Image Storage For Presentation
- Digital Mammography X-Ray Image Storage For Presentation
- Digital Mammography X-Ray Image Storage For Processing

The Siemens MagicView provides Standard Conformance to the following DICOM Query/Retrieve SOP Classes as an SCU and SCP:

Query/Retrieve SOP Classes as an SCU and SCP for:

- Patient Root Query/Retrieve Information Model - FIND
- Patient Root Query/Retrieve Information Model - MOVE

- Study Root Query/Retrieve Information Model - FIND
- Study Root Query/Retrieve Information Model - MOVE
- Patient/Study Only Query/Retrieve Information Model - FIND
- Patient/Study Only Query/Retrieve Information Model - MOVE

The Siemens MagicView provides Standard Conformance to the following DICOM Print Management SOP Classes as an SCU:

Print Management SOP Class as SCU

- Basic Grayscale Print Management

The Siemens MagicView provides Standard Conformance to the following DICOM Verification SOP Classes as an SCP:

Verification SOP Class as SCP

- Verification

The Siemens MagicView provides Standard Conformance to the following DICOM Storage Commitment SOP Class as an SCP

Storage Commitment SOP Classes as SCP

- Storage Commitment Push Model

2.1 Association Establishment Policies

2.1.1 General

The configuration of the Siemens MagicView defines the Application Entity Titles, the port numbers, the host name and net address.

2.1.1.1 Number of Associations

FOS initiates several associations at a time, one for each transfer request being processed. By default (see section 5.2 on page 53) there may be up to 5 concurrent associations initiated by FOS active at a time, which are processed in parallel.

DRCV, DQRY and DNES accept multiple associations from different remote DICOM AEs at a time (the default value is up to 10 association at a time). There may be several concurrent associations active and processed in parallel.

DQUS initiates one association at a time for C-Find and may initiate several associations at a time for C-Move, one for each transfer request.

DBP initiates one association at a time for DICOM Basic Print.

2.1.1.2 Asynchronous Nature

This version of the software does not support asynchronous communication (multiple outstanding transactions over a single association).

2.1.1.3 Implementation Identifying Information

The Siemens MagicView software provides an Implementation Class UID of “1.3.12.2.1107.5.8” and an Implementation Version Name of SNKIT_1.10”.

2.2 Association Initiation Policy

The Siemens MagicView attempts to initiate a new association for

- DIMSE-C-STORE
- DIMSE-C-FIND
- DIMSE-C-MOVE
- DIMSE-N-ACTION, DIMSE-N-SET, DIMSE-N-CREATE, DIMSE-N-GET, DIMSE-N-DELETE, DIMSE-N-EVENT-REPORT

service operations.

2.2.1 Real-World Activity - Send Image Objects to a Remote Node

2.2.1.1 Associated Real-World Activity - Send Image Objects to a Remote Node

The associated Real-World activity is a C-STORE request initiated by the user of the workstation or by internal daemon processes. If FOS successfully establishes an association to a remote Application Entity, it will transfer each image of the folder one after another via the open association. If the C-STORE Response from the remote Application contains a status other than Success, the association is aborted. After a configurable time period (see 5.2), the transfer of the folder is started again. If the Retry (3 times) also fails, the foldername will be logged on a history queue with status “Failed”. Each folder is sent over one association.

Sometimes, e.g. if a patient name has been changed, new SOP Instance UIDS are created. The original UID is saved within the Image Source Sequence (8,2112).

The DICOM targets are configured at configuration time.

2.2.1.2 Proposed Presentation Contexts

The Siemens MagicView will propose Presentation Contexts as shown in the following tables.

Table 1: Send SCU Presentation Contexts of MagicView

Presentation Context Table					
Abstract Syntax		Transfer Syntax		Role	Extended Negotiation
Name	UID	Name List	UID List		
CR Image Storage	1.2.840.10008.5.1.4.1.1.1	DICOM Implicit VR Little Endian Transfer Syntax, DICOM Explicit VR Big Endian Transfer Syntax, DICOM Explicit VR Little Endian Transfer Syntax JPEG Baseline (Process 1) Lossy JPEG Extended (Process 2 und 4) Lossy JPEG Lossless, Non-Hierarchical (Process 14)	1.2.840.10008.1.2 1.2.840.10008.1.2.2 1.2.840.10008.1.2.1 1.2.840.10008.1.2.4.50 1.2.840.10008.1.2.4.51 1.2.840.10008.1.2.4.70	SCU	None
Digital X-Ray Image Storage - For Presentation	1.2.840.10008.5.1.4.1.1.1.1	DICOM Implicit VR Little Endian Transfer Syntax, DICOM Explicit VR Big Endian Transfer Syntax, DICOM Explicit VR Little Endian Transfer Syntax JPEG Baseline (Process 1) Lossy JPEG Extended (Process 2 und 4) Lossy JPEG Lossless, Non-Hierarchical (Process 14)	1.2.840.10008.1.2 1.2.840.10008.1.2.2 1.2.840.10008.1.2.1 1.2.840.10008.1.2.4.50 1.2.840.10008.1.2.4.51 1.2.840.10008.1.2.4.70	SCU	None
Digital X-Ray Image Storage - For Processing	1.2.840.10008.5.1.4.1.1.1.1.1	DICOM Implicit VR Little Endian Transfer Syntax, DICOM Explicit VR Big Endian Transfer Syntax, DICOM Explicit VR Little Endian Transfer Syntax JPEG Baseline (Process 1) Lossy JPEG Extended (Process 2 und 4) Lossy JPEG Lossless, Non-Hierarchical (Process 14)	1.2.840.10008.1.2 1.2.840.10008.1.2.2 1.2.840.10008.1.2.1 1.2.840.10008.1.2.4.50 1.2.840.10008.1.2.4.51 1.2.840.10008.1.2.4.70	SCU	None
Digital Mammography Image Storage - For Presentation	1.2.840.10008.5.1.4.1.1.1.2	DICOM Implicit VR Little Endian Transfer Syntax, DICOM Explicit VR Big Endian Transfer Syntax, DICOM Explicit VR Little Endian Transfer Syntax JPEG Baseline (Process 1) Lossy JPEG Extended (Process 2 und 4) Lossy JPEG Lossless, Non-Hierarchical (Process 14)	1.2.840.10008.1.2 1.2.840.10008.1.2.2 1.2.840.10008.1.2.1 1.2.840.10008.1.2.4.50 1.2.840.10008.1.2.4.51 1.2.840.10008.1.2.4.70	SCU	None

Digital Mammography Image Storage - For Processing	1.2.840.10008.5.1.4.1.1.1.2.1	DICOM Implicit VR Little Endian Transfer Syntax, DICOM Explicit VR Big Endian Transfer Syntax, DICOM Explicit VR Little Endian Transfer Syntax JPEG Baseline (Process 1) Lossy JPEG Extended (Process 2 und 4) Lossy JPEG Lossless, Non-Hierarchical (Process 14)	1.2.840.10008.1.2 1.2.840.10008.1.2.2 1.2.840.10008.1.2.1 1.2.840.10008.1.2.4.50 1.2.840.10008.1.2.4.51 1.2.840.10008.1.2.4.70	SCU	None
Digital Intra-Oral X-Ray Image Storage - For Presentation	1.2.840.10008.5.1.4.1.1.1.3	DICOM Implicit VR Little Endian Transfer Syntax, DICOM Explicit VR Big Endian Transfer Syntax, DICOM Explicit VR Little Endian Transfer Syntax JPEG Baseline (Process 1) Lossy JPEG Extended (Process 2 und 4) Lossy JPEG Lossless, Non-Hierarchical (Process 14)	1.2.840.10008.1.2 1.2.840.10008.1.2.2 1.2.840.10008.1.2.1 1.2.840.10008.1.2.4.50 1.2.840.10008.1.2.4.51 1.2.840.10008.1.2.4.70	SCU	None
CT Image Storage	1.2.840.10008.5.1.4.1.1.2	DICOM Implicit VR Little Endian Transfer Syntax, DICOM Explicit VR Big Endian Transfer Syntax, DICOM Explicit VR Little Endian Transfer Syntax JPEG Extended (Process 2 und 4) Lossy JPEG Lossless, Non-Hierarchical (Process 14)	1.2.840.10008.1.2 1.2.840.10008.1.2.2 1.2.840.10008.1.2.1 1.2.840.10008.1.2.4.51 1.2.840.10008.1.2.4.70	SCU	None
US MF Image Storage Retired	1.2.840.10008.5.1.4.1.1.3	DICOM Implicit VR Little Endian Transfer Syntax, DICOM Explicit VR Big Endian Transfer Syntax, DICOM Explicit VR Little Endian Transfer Syntax JPEG Baseline (Process 1) Lossy JPEG Extended (Process 2 und 4) Lossy JPEG Lossless, Non-Hierarchical (Process 14)	1.2.840.10008.1.2 1.2.840.10008.1.2.2 1.2.840.10008.1.2.1 1.2.840.10008.1.2.4.50 1.2.840.10008.1.2.4.51 1.2.840.10008.1.2.4.70	SCU	None

Copyright © Siemens AG Medical Solutions, Health Services, 2001.
 All rights reserved. For internal use only.
 Alle Rechte vorbehalten. Nur für internen Gebrauch.

Siemens AG Medical Solutions, Health Services
 Henkestr. 127, D-91052 Erlangen

US MF Image Storage	1.2.840.10008.5.1.4.1.1.3.1	DICOM Implicit VR Little Endian Transfer Syntax, DICOM Explicit VR Big Endian Transfer Syntax, DICOM Explicit VR Little Endian Transfer Syntax JPEG Baseline (Process 1) Lossy JPEG Extended (Process 2 und 4) Lossy JPEG Lossless, Non-Hierarchical (Process 14)	1.2.840.10008.1.2 1.2.840.10008.1.2.2 1.2.840.10008.1.2.1 1.2.840.10008.1.2.4.50 1.2.840.10008.1.2.4.51 1.2.840.10008.1.2.4.70	SCU	None
MR Image Storage	1.2.840.10008.5.1.4.1.1.4	DICOM Implicit VR Little Endian Transfer Syntax, DICOM Explicit VR Big Endian Transfer Syntax, DICOM Explicit VR Little Endian Transfer Syntax JPEG Extended (Process 2 und 4) Lossy JPEG Lossless, Non-Hierarchical (Process 14)	1.2.840.10008.1.2 1.2.840.10008.1.2.2 1.2.840.10008.1.2.1 1.2.840.10008.1.2.4.51 1.2.840.10008.1.2.4.70	SCU	None
US Image Storage Retired	1.2.840.10008.5.1.4.1.1.6	DICOM Implicit VR Little Endian Transfer Syntax, DICOM Explicit VR Big Endian Transfer Syntax, DICOM Explicit VR Little Endian Transfer Syntax JPEG Baseline (Process 1) Lossy JPEG Extended (Process 2 und 4) Lossy JPEG Lossless, Non-Hierarchical (Process 14)	1.2.840.10008.1.2 1.2.840.10008.1.2.2 1.2.840.10008.1.2.1 1.2.840.10008.1.2.4.50 1.2.840.10008.1.2.4.51 1.2.840.10008.1.2.4.70	SCU	None
US Image Storage	1.2.840.10008.5.1.4.1.1.6.1	DICOM Implicit VR Little Endian Transfer Syntax, DICOM Explicit VR Big Endian Transfer Syntax, DICOM Explicit VR Little Endian Transfer Syntax JPEG Baseline (Process 1) Lossy JPEG Extended (Process 2 und 4) Lossy JPEG Lossless, Non-Hierarchical (Process 14)	1.2.840.10008.1.2 1.2.840.10008.1.2.2 1.2.840.10008.1.2.1 1.2.840.10008.1.2.4.50 1.2.840.10008.1.2.4.51 1.2.840.10008.1.2.4.70	SCU	None

<p>SC Image Storage</p>	<p>1.2.840.10008.5.1.4.1.1.7</p>	<p>DICOM Implicit VR Little Endian Transfer Syntax, DICOM Explicit VR Big Endian Transfer Syntax, DICOM Explicit VR Little Endian Transfer Syntax JPEG Baseline (Process 1) Lossy JPEG Extended (Process 2 und 4) Lossy JPEG Lossless, Non-Hierarchical (Process 14)</p>	<p>1.2.840.10008.1.2 1.2.840.10008.1.2.2 1.2.840.10008.1.2.1 1.2.840.10008.1.2.4.50 1.2.840.10008.1.2.4.51 1.2.840.10008.1.2.4.70</p>	<p>SCU</p>	<p>None</p>
<p>NM Image Storage</p>	<p>1.2.840.10008.5.1.4.1.1.20</p>	<p>DICOM Implicit VR Little Endian Transfer Syntax, DICOM Explicit VR Big Endian Transfer Syntax, DICOM Explicit VR Little Endian Transfer Syntax JPEG Baseline (Process 1) Lossy JPEG Extended (Process 2 und 4) Lossy JPEG Lossless, Non-Hierarchical (Process 14)</p>	<p>1.2.840.10008.1.2 1.2.840.10008.1.2.2 1.2.840.10008.1.2.1 1.2.840.10008.1.2.4.50 1.2.840.10008.1.2.4.51 1.2.840.10008.1.2.4.70</p>	<p>SCU</p>	<p>None</p>
<p>X-Ray Angio-graphic Image Storage</p>	<p>1.2.840.10008.5.1.4.1.1.12.1</p>	<p>DICOM Implicit VR Little Endian Transfer Syntax, DICOM Explicit VR Big Endian Transfer Syntax, DICOM Explicit VR Little Endian Transfer Syntax JPEG Baseline (Process 1) Lossy JPEG Extended (Process 2 und 4) Lossy JPEG Lossless, Non-Hierarchical (Process 14)</p>	<p>1.2.840.10008.1.2 1.2.840.10008.1.2.2 1.2.840.10008.1.2.1 1.2.840.10008.1.2.4.50 1.2.840.10008.1.2.4.51 1.2.840.10008.1.2.4.70</p>	<p>SCU</p>	<p>None</p>
<p>X-Ray Radiofluoroscopic Image Storage</p>	<p>1.2.840.10008.5.1.4.1.1.12.2</p>	<p>DICOM Implicit VR Little Endian Transfer Syntax, DICOM Explicit VR Big Endian Transfer Syntax, DICOM Explicit VR Little Endian Transfer Syntax JPEG Baseline (Process 1) Lossy JPEG Extended (Process 2 und 4) Lossy JPEG Lossless, Non-Hierarchical (Process 14)</p>	<p>1.2.840.10008.1.2 1.2.840.10008.1.2.2 1.2.840.10008.1.2.1 1.2.840.10008.1.2.4.50 1.2.840.10008.1.2.4.51 1.2.840.10008.1.2.4.70</p>	<p>SCU</p>	<p>None</p>

Copyright © Siemens AG Medical Solutions, Health Services, 2001.
All rights reserved. For internal use only.
Alle Rechte vorbehalten. Nur für internen Gebrauch.

Siemens AG Medical Solutions, Health Services
Henkestr. 127, D-91052 Erlangen

RT Image Storage	1.2.840.10008.5.1.4.1.1.481.1	DICOM Implicit VR Little Endian Transfer Syntax, DICOM Explicit VR Big Endian Transfer Syntax, DICOM Explicit VR Little Endian Transfer Syntax JPEG Baseline (Process 1) Lossy JPEG Extended (Process 2 und 4) Lossy JPEG Lossless, Non-Hierarchical (Process 14	1.2.840.10008.1.2 1.2.840.10008.1.2.2 1.2.840.10008.1.2.1 1.2.840.10008.1.2.4.50 1.2.840.10008.1.2.4.51 1.2.840.10008.1.2.4.70	SCU	None
Positron Emission Tomography Image Storage	1.2.840.10008.5.1.4.1.1.128	DICOM Implicit VR Little Endian Transfer Syntax, DICOM Explicit VR Big Endian Transfer Syntax, DICOM Explicit VR Little Endian Transfer Syntax JPEG Baseline (Process 1) Lossy JPEG Extended (Process 2 und 4) Lossy JPEG Lossless, Non-Hierarchical (Process 14)	1.2.840.10008.1.2 1.2.840.10008.1.2.2 1.2.840.10008.1.2.1 1.2.840.10008.1.2.4.50 1.2.840.10008.1.2.4.51 1.2.840.10008.1.2.4.70	SCU	None

2.2.1.3 SOP Specific Conformance Statement

The DICOM images sent by the Siemens MagicView 1000 conform to the DICOM IOD definitions (Standard extended IODs).

Siemens image objects (as well as images from other manufacturers) may contain additional private elements which have to be discarded by a DICOM System when modifying the image.

Overlay data created by the MagicView1000 are stored in (60xx,3000).

The DICOM nodes are responsible for data consistency when modifying images. All unknown private attributes have to be removed upon modification!

Sending different folder will open a new association for each folder.

Only if the following statements are true an Internal Data Set Object can be altered with JPEG Lossless Compression:

- Photometric Interpretation (0028,0004) is MONOCHROME1 or MONOCHROME2 (means a gray scale image)
- Bits Allocated (0028,0100) is 16 or 8
- Bits Stored (0028,0101) is 16,12,10 or 8
- High Bit (0028,0102) is Bits Stored (0028,0101) - 1
- Pixel Data (7FE0,0010) exists and matrix is not already compressed

Only if the following statements are true an Internal Data Set Object can be altered with JPEG Lossy Compression:

- Photometric Interpretation (0028,0004) is MONOCHROME1, MONOCHROME2 (means a gray scale image) or RGB
- Bits Allocated (0028,0100) is 16 or 8 for MONOCHROME1 and MONOCHROME2 or 8 for RGB
- Bits Stored (0028,0101) is 12,10 or 8 for MONOCHROME1 and MONOCHROME2 or 8 for RGB
- High Bit (0028,0102) is Bits Stored (0028,0101) - 1 for MONOCHROME1 and MONOCHROME2 or 7 for RGB
- Pixel Data (7FE0,0010) exists and matrix is not already compressed

2.2.1.4 Images resulting from 3D postprocessing

3D result images will be sent as “Secondary Captured” images. The value for (0008/0060) “Modality” will be retained (i.e. copied from the source images).

Table 2: Modality and SOP Class UID of 3D result images

Modality: (0008/0060)	SOP Class UID:(0008/0016)
CT or MR	1.2.840.10008.5.1.4.1.1.7

3D result images have one of the following pixel formats:

Table 3: Pixel formats of 3D result images

Pixel Re- presentation: (0028/ 0103)	Samples per Pixel: (0028/ 0002)	Photometric Interpretation: (0028/ 0004)	Planar Configu- ration: (0028/ 0006)	Bits Alloca- ted: (0028/ 0100)	Bits Stored: (0028/ 0101)	High Bit: (0028/ 0102)
0000	1	MONOCHROME1	n.a.	16	12	11
0000	1	MONOCHROME2	n.a.	16	12	11
0000	3	RGB	0	8	7	7

The values 1,2,3,and 4 for (0008/0008) “Image Type” for 3D result images will be as follows:

- Pixel Data Characteristics: value 1:DERIVED
- Patient Examination Characteristics: value 2:SECONDARY
- Modality Specific Specialization: value 3:OTHER
- Implementation specific Identifier: value 4:see table 3

Table 4: Image Type (0008/0008), value 4 of 3D result images

Image Type: (0008/0008) value 4	Description:
SHS 3D_MPR	Multi Planar Reformatting / Reconstruction (MPR)
SHS 3D_CURVED	Curved Multi Planar Reformatting / Reconstruction (MPR)
SHS 3D_MIP	Maximum or Minimum Intensity Projection (MIP)
SHS 3D_VRT	Volumetric Rendering (VRT)
SHS 3D_SSD	Shaded Surface Display (SSD)
SHS DENT	Dental Reference Tomogram (Dental package only)
SHS DPAN	Dental Panorama View (Dental Package only)
SHS DPAR	Dental Paraxial View (Dental package only)

2.2.1.5 Images resulting from Image Composition

Composed images will be sent as “Secondary Captured” images. The value for (0008/0060) “Modality” as well as the pixel format will be the same as in the source images.

Table 5: SOP Class UID of Composed Images

SOP Class UID:(0008/0016)
1.2.840.10008.5.1.4.1.1.7

The values 1,2,3,and 4 for (0008/0008) “Image Type” for composed images will be as follows:

- Pixel Data Characteristics: value 1:DERIVED
- Patient Examination Characteristics: value 2:SECONDARY
- Modality Specific Specialization: value 3:MANUEL_RECONSTRUCTED
- Implementation specific Identifier: value 4:VB33A

2.2.2 Real-World Activity - Query the Image Database of a remote node

2.2.2.1 Associated Real-World Activity - Query the Image Database of a Remote Node

The associated Real-World activity is a C-Find request initiated by the user of the workstation. The user specifies some attributes that the remote Application should use to query the database. If DQUS successfully establishes an association to the remote Application Entity, it will send one or more C-Find requests (according the query model) and will then return the results to the displaying process of the MagicView 1000.

2.2.2.2 Proposed Presentation Contexts

The Siemens MagicView 1000 will propose Presentation Contexts as shown in the following tables.

Table 6: Query SCU Presentation Contexts of MagicView 1000

Presentation Context Table					
Abstract Syntax		Transfer Syntax		Role	Extend ed Negotia tion
Name	UID	Name List	UID List		
Patient Root Query/ Retrieve Information Model - FIND	1.2.840.10008.5.1.4.1.2.1.1	DICOM Implicit VR Little Endian Transfer Syntax	1.2.840.10008.1.2	SCU	None
		DICOM Explicit VR Big Endian Transfer Syntax	1.2.840.10008.1.2.2		
		DICOM Explicit VR Little Endian Transfer Syntax	1.2.840.10008.1.2.1		
Study Root Query/ Retrieve Information Model - FIND	1.2.840.10008.5.1.4.1.2.2.1	DICOM Implicit VR Little Endian Transfer Syntax	1.2.840.10008.1.2	SCU	None
		DICOM Explicit VR Big Endian Transfer Syntax	1.2.840.10008.1.2.2		
		DICOM Explicit VR Little Endian Transfer Syntax	1.2.840.10008.1.2.1		
Patient/Study Only Query/ Retrieve Information Model - FIND	1.2.840.10008.5.1.4.1.2.3.1	DICOM Implicit VR Little Endian Transfer Syntax	1.2.840.10008.1.2	SCU	None
		DICOM Explicit VR Big Endian Transfer Syntax	1.2.840.10008.1.2.2		
		DICOM Explicit VR Little Endian Transfer Syntax	1.2.840.10008.1.2.1		

The default proposed transfer syntax is DICOM Implicit VR Little Endian Transfer Syntax. The default Query/Retrieve Information Model for C-Find requests is the Study Root Query/Retrieve Information Model.

2.2.2.3 SOP Specific Conformance Statement

DQUS supports the Patient Root Query Model, the Study Root Query Model and the Patient-Study-Only Query Model. By default DQUS initiates a hierarchical Study Root query. The relational query method can be configured (see 5.2).

2.2.2.3.1 Patient Root C-Find SOP Class Specific Conformance Statement

Table 7: Supported Patient level attributes

Description	Tag
Patient's Name	(0010,0010)
Patient ID	(0010,0020)
Patient's Birth Date	(0010,0030)
Patient's Sex	(0010,0040)
Other Patient IDs	(0010,1000)
Patient Comments	(0010,4000)

Table 8: Supported Study level attributes

Description	Tag
Study Date	(0008,0020)
Study Time	(0008,0030)
Accession Number	(0008,0050)
Modalities in Study	(0008,0061)
Referring Physician's Name	(0008,0090)
Study Description	(0008,1030)
Name of Physician(s) Reading Study	(0008,1060)
Study Instance UID	(0020,000D)
Study ID	(0020,0010)
Number of Study Related Images	(0020,1208)

Table 9: Supported Series level attributes

Description	Tag
Modality	(0008,0060)

Description	Tag
Series Instance UID	(0020,000E)
Series Number	(0020,0011)
Requested Procedure ID	(0040,1001)
Perf. Proc. Step Start Date	(0040,0244)
Perf. Proc. Step Start Time	(0040,0245)

The attribute Number Of Series Related Instances (20,1209) is not supported. The Requested Procedure ID is sent within the Request Attributes Sequence.

Table 10: Supported Image level attributes

Description	Tag
Image Number	(0020,0013)
SOP Instance UID	(0008,0018)

2.2.2.3.2 Study Root C-Find SOP Class Specific Conformance Statement

Table 11: Supported Study level attributes

Description	Tag
Patient's Name	(0010,0010)
Patient ID	(0010,0020)
Patient's Birth Date	(0010,0030)
Patient's Sex	(0010,0040)
Other Patient IDs	(0010,1000)
Patient Comments	(0010,4000)
Study Date	(0008,0020)
Study Time	(0008,0030)
Accession Number	(0008,0050)
Modalities in Study	(0008,0061)

Description	Tag
Referring Physician's Name	(0008,0090)
Study Description	(0008,1030)
Name of Physician(s) Reading Study	(0008,1060)
Study Instance UID	(0020,000D)
Study ID	(0020,0010)
Number of Study Related Images	(0020,1208)

- The same Series level attributes as in the Patient Root C-Find SOP class are supported.
- The same Image level attributes as in the Patient Root C-Find SOP class are supported.

2.2.2.3.3 Patient/Study Only C-Find SOP Class Specific Conformance Statement

- The same Patient level attributes as in the Patient Root C-Find SOP class are supported.
- The same Study level attributes as in the Patient Root C-Find SOP class are supported.

By default the MagicView will be configured to show only studies in the query matches list. Even if series or image level attributes are requested and DQUS initiates a C-Find request on series or image level, as a result only the values of the first series or image within a study are displayed. A following retrieve will be performed on study level as well.

If the MagicView is not configured to show only studies (see 5.2) the query level as well as the retrieve level depend on the level of the requested attributes. That means the query matches list displays either studies, series or images. A following retrieve will be performed on the level displayed.

The timeout for waiting on a C-Find Response can be configured. Its default is set to 60 seconds.

2.2.3 Real-World Activity - Retrieve Image Objects from a Remote Node

2.2.3.1 Associated Real-World Activity - Retrieve Image Objects from a Remote Node

The associated Real-World activity is a C-Move request initiated by the user of the workstation. The user selects one or more studies, series or images from a list generated as a result of the previous C-Find operation. If DQUS successfully establishes an association to the remote Ap-

plication Entity, it will cause the calling application via a C-Move request to transfer the images to the local Application Entity. The transfer of the images will be done by a subsequent C-Store and will return the results of the store operation to the calling application.

2.2.3.2 Proposed Presentation Contexts

The Siemens MagicView 1000 will propose Presentation Contexts as shown in the following tables.

Table 12: C-Move SCU Presentation Contexts of MagicView 1000

Presentation Context Table					
Abstract Syntax		Transfer Syntax		Role	Extended Negotiation
Name	UID	Name List	UID List		
Patient Root Query/ Retrieve Information Model - MOVE	1.2.840.10008.5.1.4.1.2.1.2	DICOM Implicit VR Little Endian Transfer Syntax	1.2.840.10008.1.2	SCU	None
		DICOM Explicit VR Big Endian Transfer Syntax	1.2.840.10008.1.2.2		
		DICOM Explicit VR Little Endian Transfer Syntax	1.2.840.10008.1.2.1		
Study Root Query/ Retrieve Information Model - MOVE	1.2.840.10008.5.1.4.1.2.2.2	DICOM Implicit VR Little Endian Transfer Syntax	1.2.840.10008.1.2	SCU	None
		DICOM Explicit VR Big Endian Transfer Syntax,	1.2.840.10008.1.2.2		
		DICOM Explicit VR Little Endian Transfer Syntax	1.2.840.10008.1.2.1		
Patient/Study Only Query/ Retrieve Information Model - MOVE	1.2.840.10008.5.1.4.1.2.3.2	DICOM Implicit VR Little Endian Transfer Syntax	1.2.840.10008.1.2	SCU	None
		DICOM Explicit VR Big Endian Transfer Syntax	1.2.840.10008.1.2.2		
		DICOM Explicit VR Little Endian Transfer Syntax	1.2.840.10008.1.2.1		

The default proposed transfer syntax is DICOM Implicit VR Little Endian Transfer Syntax. The default Query/Retrieve Information Model for C-Move requests is the Study Root Retrieve Information Model.

2.2.3.3 SOP Specific Conformance Statement

If the MagicView is configured to show only studies in the query matches list (see 2.2.2.3) the retrieve level is always study level. Otherwise the retrieve level depends on the requested attributes and can be either study, series or image level.

The timeout for waiting on a C-Move response can be configured. Its default is set to 10 minutes.

Copyright © Siemens AG Medical Solutions, Health Services, 2001.
All rights reserved. For internal use only.
Alle Rechte vorbehalten. Nur für internen Gebrauch.

Siemens AG Medical Solutions, Health Services
Henkestr. 127, D-91052 Erlangen

2.2.4 Real-World Activity - Send Print Request to a Remote Node

2.2.4.1 Associated Real-World Activity - Send Print Request to a Remote Node

The associated Real-World activity is a folder print request initiated by the user of the workstation.

If the DBP successfully establishes an association to the remotepriinter Application Entity, it will send N_GET, N_CREATE, N_SET, N_ACTION and N_DELETE requests to the remote printer.

The Printer SOP Class accepts N_EVENT_REPORT Requests.

The Siemens MagicView 1000 will propose Presentation Contexts as shown in the following tables.

Table 13: MagicView 1000 Print Management SCU Presentation Contexts of

Presentation Context Table					
Abstract Syntax		Transfer Syntax		Role	Extend ed Negotia tion
Name	UID	Name List	UID List		
Basic Grayscale Print Management	1.2.840.10008.5.1.1.9	DICOM Implicit VR Little Endian Transfer Syntax	1.2.840.10008.1.2	SCU	None
		DICOM Explicit VR Big Endian Transfer Syntax	1.2.840.10008.1.2.2		
		DICOM Explicit VR Little Endian Transfer Syntax	1.2.840.10008.1.2.1		

Siemens MagicView supports the following mandatory SOP Classes as defined by the Basic Grayscale Print Management Meta Class:

SOP Class Name	SOP Class UID
Basic Film Session SOP Class	1.2.840.10008.5.1.1.1
Basic Film Box SOP Class	1.2.840.10008.5.1.1.2
Basic Grayscale Image Box SOP Class	1.2.840.10008.5.1.1.4
Printer SOP Class	1.2.840.10008.5.1.1.16

DBP does not support any optional SOP Classes.

2.2.4.2 Basic Film Session SOP Class

Table 14: Supported N_CREATE attributes

Description	Tag	Value
Number of Copies	(2000, 0010)	> 0

After use the Basic Film Session is closed with N_DELETE.

2.2.4.3 Basic Film Box SOP Class

Table 15: Supported N_CREATE attributes

Description	Tag	Value
Image Display Format	(2010, 0010)	STANDARD\1,1
Film Orientation	(2010, 0040)	PORTRAIT
Film Size ID	(2010, 0050)	14INX17IN, 14INX14IN, 11INX14IN, 8INX10IN, 10INX12IN, 10INX14IN, 24CMx24CM, 24CMX30CM
Magnification Type	(2010, 0060)	REPLICATE, BILINEAR, CUBIC
Min Density	(2010, 0120)	>= 0
Max Density	(2010, 0130)	> 0
Configuration Information	(2010, 0150)	Any character string, values must be taken from the SCP's Conformance Statement.
Referenced Film Session Sequence	(2010, 0500)	

Min Density and Configuration Information are only created after a special configuration.

N_ACTION is used to start printing.

2.2.4.4 Basic Grayscale Image Box SOP Class

Table 16: Supported N_SET attributes

Description	Tag	Value
Sample Per Pixel	(0028, 0002)	1
Photometric Interpretation	(0028, 0004)	MONOCHROME2
Rows	(0028, 0010)	> 0
Columns	(0028, 0011)	> 0
Pixel Aspect Ratio	(0028, 0034)	1\1
Bits Allocated	(0028, 0100)	8
Bits Stored	(0028, 0101)	8
High Bit	(0028, 0102)	7
Pixel Representation	(0028, 0103)	0
Image Position	(2020, 0010)	1
Polarity	(2020, 0020)	NORMAL
Basic Grayscale Image Sequence	(2020, 0110)	
Pixel Data	(7FE0, 0010)	

2.2.4.5 Printer SOP Class

Table 17: Supported N-GET attributes

Description	Tag
Printer Status	(2110, 0010)
Printer Status Info	(2110, 0020)
Printer Name	(2110, 0030)
Manufacturer	(0008, 0070)
Manufacturer Model Name	(0008, 1090)
Device Serial Number	(0018, 1000)
Software Version	(0018, 1020)
Date Of Last Calibration	(0018, 1200)
Time Of Last Calibration	(0018, 1201)

2.2.4.6 SOP Specific Conformance Statement

Only one association will be processed at a time.

In case of a failure return status of the Print SCP, the current job will be suspended.

Default time-out values are:

- time-out for accepting/rejecting an association request: 30 sec
- time-out for responding to an association open/close request: 15 sec
- time-out for accepting a message over the network: 15 sec
- time-out for a network connect to be accepted: 15 sec
- time-out for waiting for data between packets: 15 sec

2.3 Association Acceptance Policy

The Siemens MagicView 1000 accepts a new association for

- DIMSE-C-ECHO
- DIMSE-C-STORE
- DIMSE-C-FIND
- DIMSE-C-MOVE
- DIMSE-N-ACTION
- DIMSE-N-EVENT-REPORT(see 2.2.4.1)

service operations.

2.3.1 Real-World Activity - Receive Echo

2.3.1.1 Associated Real-World Activity - respond to echo request

The associated Real-World activity is a C-Echo response by the DRCV and DQRY.

2.3.1.2 Accepted Presentation Contexts

The Siemens MagicView 1000 will accept Presentation Contexts for Verification as shown in the following table.

Table 18: Echo SCP Presentation Contexts of MagicView 1000

Presentation Context Table					
Abstract Syntax		Transfer Syntax		Role	Extend ed Negoti ation
Name	UID	Name List	UID List		
Verification Service class	1.2.840.10008.1.1	DICOM Implicit VR Little Endian Transfer Syntax	1.2.840.10008.1.2	SCP	None
		DICOM Explicit VR Big Endian Transfer Syntax,	1.2.840.10008.1.2.1		
		DICOM Explicit VR Little Endian Transfer Syntax	1.2.840.10008.1.2.2		

2.3.1.3 SOP Specific Conformance to the Verification SOP Class

MagicView provides standard conformance to the DICOM Verification SOP Class. The DICOM MagicView 1000 accepts any Application Title from the SCU.

2.3.2 Real-World Activity - Receive Image Objects from a Remote Node

2.3.2.1 Associated Real-World Activity -Receive Image Objects from a Remote Node

The associated Real-World activity is a C-Store request received by the daemon process DRCV. After accepting an association from a remote DICOM AE, the DRCV process receives the images via the open association.

After the association is closed by the sender, DRCV initiates the transfer of the images into the MagicView's database. If the transfer fails, DRCV returns an error status.

2.3.2.2 Accepted Presentation Contexts

The Siemens MagicView 1000 will accept Presentation Contexts as shown in the following tables.

Table 19: Send SCP Presentation Contexts of MagicView 1000

Presentation Context Table					
Abstract Syntax		Transfer Syntax		Role	Extended Negotiation
Name	UID	Name List	UID List		
CR Image Storage	1.2.840.10008.5.1.4.1.1.1	DICOM Implicit VR Little Endian Transfer Syntax, DICOM Explicit VR Big Endian Transfer Syntax, DICOM Explicit VR Little Endian Transfer Syntax JPEG Baseline (Process 1) Lossy JPEG Extended (Process 2 und 4) Lossy JPEG Lossless, Non-Hierarchical (Process 14)	1.2.840.10008.1.2 1.2.840.10008.1.2.2 1.2.840.10008.1.2.1 1.2.840.10008.1.2.4.50 1.2.840.10008.1.2.4.51 1.2.840.10008.1.2.4.70	SCP	None
Digital X-Ray Image Storage - For Presentation	1.2.840.10008.5.1.4.1.1.1.1	DICOM Implicit VR Little Endian Transfer Syntax, DICOM Explicit VR Big Endian Transfer Syntax, DICOM Explicit VR Little Endian Transfer Syntax JPEG Baseline (Process 1) Lossy JPEG Extended (Process 2 und 4) Lossy JPEG Lossless, Non-Hierarchical (Process 14)	1.2.840.10008.1.2 1.2.840.10008.1.2.2 1.2.840.10008.1.2.1 1.2.840.10008.1.2.4.50 1.2.840.10008.1.2.4.51 1.2.840.10008.1.2.4.70	SCP	None
Digital X-Ray Image Storage - For Processing	1.2.840.10008.5.1.4.1.1.1.1.1	DICOM Implicit VR Little Endian Transfer Syntax, DICOM Explicit VR Big Endian Transfer Syntax, DICOM Explicit VR Little Endian Transfer Syntax JPEG Baseline (Process 1) Lossy JPEG Extended (Process 2 und 4) Lossy JPEG Lossless, Non-Hierarchical (Process 14)	1.2.840.10008.1.2 1.2.840.10008.1.2.2 1.2.840.10008.1.2.1 1.2.840.10008.1.2.4.50 1.2.840.10008.1.2.4.51 1.2.840.10008.1.2.4.70	SCP	None
Digital Mammography Image Storage - For Presentation	1.2.840.10008.5.1.4.1.1.1.2	DICOM Implicit VR Little Endian Transfer Syntax, DICOM Explicit VR Big Endian Transfer Syntax, DICOM Explicit VR Little Endian Transfer Syntax JPEG Baseline (Process 1) Lossy JPEG Extended (Process 2 und 4) Lossy JPEG Lossless, Non-Hierarchical (Process 14)	1.2.840.10008.1.2 1.2.840.10008.1.2.2 1.2.840.10008.1.2.1 1.2.840.10008.1.2.4.50 1.2.840.10008.1.2.4.51 1.2.840.10008.1.2.4.70	SCP	None

Copyright © Siemens AG Medical Solutions, Health Services, 2001.
All rights reserved. For internal use only.
Alle Rechte vorbehalten. Nur für internen Gebrauch.

Siemens AG Medical Solutions, Health Services
Henkestr. 127, D-91052 Erlangen

Digital Mammography Image Storage - For Processing	1.2.840.10008.5.1.4.1.1.1.2.1	DICOM Implicit VR Little Endian Transfer Syntax, DICOM Explicit VR Big Endian Transfer Syntax, DICOM Explicit VR Little Endian Transfer Syntax JPEG Baseline (Process 1) Lossy JPEG Extended (Process 2 und 4) Lossy JPEG Lossless, Non-Hierarchical (Process 14)	1.2.840.10008.1.2 1.2.840.10008.1.2.2 1.2.840.10008.1.2.1 1.2.840.10008.1.2.4.50 1.2.840.10008.1.2.4.51 1.2.840.10008.1.2.4.70	SCP	None
Digital Intra-Oral X-Ray Image Storage - For Presentation	1.2.840.10008.5.1.4.1.1.1.3	DICOM Implicit VR Little Endian Transfer Syntax, DICOM Explicit VR Big Endian Transfer Syntax, DICOM Explicit VR Little Endian Transfer Syntax JPEG Baseline (Process 1) Lossy JPEG Extended (Process 2 und 4) Lossy JPEG Lossless, Non-Hierarchical (Process 14)	1.2.840.10008.1.2 1.2.840.10008.1.2.2 1.2.840.10008.1.2.1 1.2.840.10008.1.2.4.50 1.2.840.10008.1.2.4.51 1.2.840.10008.1.2.4.70	SCP	None
CT Image Storage	1.2.840.10008.5.1.4.1.1.2	DICOM Implicit VR Little Endian Transfer Syntax, DICOM Explicit VR Big Endian Transfer Syntax, DICOM Explicit VR Little Endian Transfer Syntax JPEG Extended (Process 2 und 4) Lossy JPEG Lossless, Non-Hierarchical (Process 14)	1.2.840.10008.1.2 1.2.840.10008.1.2.2 1.2.840.10008.1.2.1 1.2.840.10008.1.2.4.51 1.2.840.10008.1.2.4.70	SCP	None
US MF Image Storage Retired	1.2.840.10008.5.1.4.1.1.3	DICOM Implicit VR Little Endian Transfer Syntax, DICOM Explicit VR Big Endian Transfer Syntax, DICOM Explicit VR Little Endian Transfer Syntax JPEG Baseline (Process 1) Lossy JPEG Extended (Process 2 und 4) Lossy JPEG Lossless, Non-Hierarchical (Process 14)	1.2.840.10008.1.2 1.2.840.10008.1.2.2 1.2.840.10008.1.2.1 1.2.840.10008.1.2.4.50 1.2.840.10008.1.2.4.51 1.2.840.10008.1.2.4.70	SCP	None

US MF Image Storage	1.2.840.10008.5.1.4.1.1.3.1	DICOM Implicit VR Little Endian Transfer Syntax, DICOM Explicit VR Big Endian Transfer Syntax, DICOM Explicit VR Little Endian Transfer Syntax JPEG Baseline (Process 1) Lossy JPEG Extended (Process 2 und 4) Lossy JPEG Lossless, Non-Hierarchical (Process 14)	1.2.840.10008.1.2 1.2.840.10008.1.2.2 1.2.840.10008.1.2.1 1.2.840.10008.1.2.4.50 1.2.840.10008.1.2.4.51 1.2.840.10008.1.2.4.70	SCP	None
MR ImageStorage	1.2.840.10008.5.1.4.1.1.4	DICOM Implicit VR Little Endian Transfer Syntax, DICOM Explicit VR Big Endian Transfer Syntax, DICOM Explicit VR Little Endian Transfer Syntax JPEG Extended (Process 2 und 4) Lossy JPEG Lossless, Non-Hierarchical (Process 14)	1.2.840.10008.1.2 1.2.840.10008.1.2.2 1.2.840.10008.1.2.1 1.2.840.10008.1.2.4.51 1.2.840.10008.1.2.4.70	SCP	None
US Image Storage Retired	1.2.840.10008.5.1.4.1.1.6	DICOM Implicit VR Little Endian Transfer Syntax, DICOM Explicit VR Big Endian Transfer Syntax, DICOM Explicit VR Little Endian Transfer Syntax JPEG Baseline (Process 1) Lossy JPEG Extended (Process 2 und 4) Lossy JPEG Lossless, Non-Hierarchical (Process 14)	1.2.840.10008.1.2 1.2.840.10008.1.2.2 1.2.840.10008.1.2.1 1.2.840.10008.1.2.4.50 1.2.840.10008.1.2.4.51 1.2.840.10008.1.2.4.70	SCP	None
US Image Storage	1.2.840.10008.5.1.4.1.1.6.1	DICOM Implicit VR Little Endian Transfer Syntax, DICOM Explicit VR Big Endian Transfer Syntax, DICOM Explicit VR Little Endian Transfer Syntax JPEG Baseline (Process 1) Lossy JPEG Extended (Process 2 und 4) Lossy JPEG Lossless, Non-Hierarchical (Process 14)	1.2.840.10008.1.2 1.2.840.10008.1.2.2 1.2.840.10008.1.2.1 1.2.840.10008.1.2.4.50 1.2.840.10008.1.2.4.51 1.2.840.10008.1.2.4.70	SCP	None

Copyright © Siemens AG Medical Solutions, Health Services, 2001.
All rights reserved. For internal use only.
Alle Rechte vorbehalten. Nur für internen Gebrauch.

Siemens AG Medical Solutions, Health Services
Henkestr. 127, D-91052 Erlangen

SC Image Storage	1.2.840.10008.5.1.4.1.1.7	DICOM Implicit VR Little Endian Transfer Syntax, DICOM Explicit VR Big Endian Transfer Syntax, DICOM Explicit VR Little Endian Transfer Syntax JPEG Baseline (Process 1) Lossy JPEG Extended (Process 2 und 4) Lossy JPEG Lossless, Non-Hierarchical (Process 14)	1.2.840.10008.1.2 1.2.840.10008.1.2.2 1.2.840.10008.1.2.1 1.2.840.10008.1.2.4.50 1.2.840.10008.1.2.4.51 1.2.840.10008.1.2.4.70	SCP	None
NM Image Storage	1.2.840.10008.5.1.4.1.1.20	DICOM Implicit VR Little Endian Transfer Syntax, DICOM Explicit VR Big Endian Transfer Syntax, DICOM Explicit VR Little Endian Transfer Syntax JPEG Baseline (Process 1) Lossy JPEG Extended (Process 2 und 4) Lossy JPEG Lossless, Non-Hierarchical (Process 14)	1.2.840.10008.1.2 1.2.840.10008.1.2.2 1.2.840.10008.1.2.1 1.2.840.10008.1.2.4.50 1.2.840.10008.1.2.4.51 1.2.840.10008.1.2.4.70	SCP	None
X-Ray Angio-graphic Image Storage	1.2.840.10008.5.1.4.1.1.12.1	DICOM Implicit VR Little Endian Transfer Syntax, DICOM Explicit VR Big Endian Transfer Syntax, DICOM Explicit VR Little Endian Transfer Syntax JPEG Baseline (Process 1) Lossy JPEG Extended (Process 2 und 4) Lossy JPEG Lossless, Non-Hierarchical (Process 14)	1.2.840.10008.1.2 1.2.840.10008.1.2.2 1.2.840.10008.1.2.1 1.2.840.10008.1.2.4.50 1.2.840.10008.1.2.4.51 1.2.840.10008.1.2.4.70	SCP	None
X-Ray Radiofluoroscopic Image Storage	1.2.840.10008.5.1.4.1.1.12.2	DICOM Implicit VR Little Endian Transfer Syntax, DICOM Explicit VR Big Endian Transfer Syntax, DICOM Explicit VR Little Endian Transfer Syntax JPEG Baseline (Process 1) Lossy JPEG Extended (Process 2 und 4) Lossy JPEG Lossless, Non-Hierarchical (Process 14)	1.2.840.10008.1.2 1.2.840.10008.1.2.2 1.2.840.10008.1.2.1 1.2.840.10008.1.2.4.50 1.2.840.10008.1.2.4.51 1.2.840.10008.1.2.4.70	SCP	None

RT Image Storage	1.2.840.10008.5.1.4.1.1.481.1	DICOM Implicit VR Little Endian Transfer Syntax, DICOM Explicit VR Big Endian Transfer Syntax, DICOM Explicit VR Little Endian Transfer Syntax JPEG Baseline (Process 1) Lossy JPEG Extended (Process 2 und 4) Lossy JPEG Lossless, Non-Hierarchical (Process 14)	1.2.840.10008.1.2 1.2.840.10008.1.2.2 1.2.840.10008.1.2.1 1.2.840.10008.1.2.4.50 1.2.840.10008.1.2.4.51 1.2.840.10008.1.2.4.70	SCP	None
Positron Emission Tomography Image Storage	1.2.840.10008.5.1.4.1.1.128	DICOM Implicit VR Little Endian Transfer Syntax, DICOM Explicit VR Big Endian Transfer Syntax, DICOM Explicit VR Little Endian Transfer Syntax JPEG Baseline (Process 1) Lossy JPEG Extended (Process 2 und 4) Lossy JPEG Lossless, Non-Hierarchical (Process 14)	1.2.840.10008.1.2 1.2.840.10008.1.2.2 1.2.840.10008.1.2.1 1.2.840.10008.1.2.4.50 1.2.840.10008.1.2.4.51 1.2.840.10008.1.2.4.70	SCP	None

2.3.2.3 SOP Specific Conformance Statement

The Siemens MagicView conforms to the Full Storage Service Class at Level 2. No Type 1, Type 2 or Type 3 attributes are discarded from the image. Even elements specified by tags not included in the DICOM standard will be kept.

Images with identical Study Instance UID sent in one association or images with identical Study Instance UID sent in multiple associations within a configurable time (default time is 0, see 5.2) are grouped into one folder. Images received after time expired are assigned a new folder identification.

The MagicView can be configured to save the patient name in a standardized (normated) format, e.g. the format used by the RIS. The original name is saved in the private tag (0095,0020).

If an image does not contain a patient name, the patient ID will be used as patient name. If an image does neither contain patient name nor patient ID, the patient name is “no name”.

If patient demographics or image information are modified later on, the original header could be modified and private elements might be discarded in order to prevent inconsistencies in elements not known to the MagicView.

Only if the following statements are true a Data Set Object with JPEG Lossless Compression can be received:

- Photometric Interpretation (0028,0004) is MONOCHROME1 or MONOCHROME2 (means a gray scale image)
- Bits Allocated (0028,0100) is 16 or 8
- Bits Stored (0028,0101) is 16,12,10 or 8

- High Bit (0028,0102) is Bits Stored (0028,0101) - 1

Only if the following statements are true a Data Set Object with JPEG Lossy Compression can be received:

- Photometric Interpretation (0028,0004) is MONOCHROME1, MONOCHROME2 (means a gray scale image) or RGB
- Bits Allocated (0028,0100) is 16 or 8 for MONOCHROME1 and MONOCHROME2 or 8 for RGB
- Bits Stored (0028,0101) is 12,10 or 8 for MONOCHROME1 and MONOCHROME2 or 8 for RGB
- High Bit (0028,0102) is Bits Stored (0028,0101) - 1 for MONOCHROME1 and MONOCHROME2 or 7 for RGB

Photometric interpretation value HSV might be converted to RGB. Overlay information within the pixel matrix might be discarded and stored in a single overlay plane.

In order to be displayed the Data Objects must meet the following Pixel format requirements:

- 0028/0002 Samples per Pixel must have a value of 1 or 3 (which means that ARGB and CMYK are not supported).
- 0028/0004 Photometric Interpretation must have a value of Monochrome 1, Monochrome 2, Palette Color if 0028/0002 has the value 1.
- 0028/0004 must have a value of RGB, HSV if 0028/0002 has the value 3.
- 0028/0100 Bits Allocated must be 8 or 16 (decimal)
- at least one of 0028/0101 and 0028/0102 must have a value.
- 0028/0102 High Bit must have the value of Bits Stored minus 1 (right justified).
- Either 0028/1050 and 0028/1051 or 0028/3010 for VOI-LUT as well as 0028/1052 and 0028/1053 should have values, which allow the image to be displayed on another station.
- Bits of the pixel data, which are not described by groups 0028 and 60xx (00<=xx<=1e) must be set to 0.

In order to display the images, sometimes pixels may need to be altered (see second part of the following table).

Table 20: Pixel formats

	28/103	28/2	28/4	28/6	28/100	28/101	28/102
PIXEL OK			MONOCHROME1		16	12	11
					8	8	7
	0000	1		n.a.		12	11
			MONOCHROME2		16	10	9
					8	8	7
		3	RGB	0000	8	8	7
CONVERTABLE	0000	1	MONOCHROME1 MONOCHROME2 PALETTE COLOR		16	>12 <=16	
					16	8	7
		3	RGB HSV	0001	8	8	7
	0001	1	MONOCHROME1 MONOCHROME2 PALETTE COLOR		16	<=16	

If images contain pixel data in which the difference between the least and the highest value is greater than 4095 pixel data will get lost as soon as the images are displayed. In case the MagicView receives images with a non-square pixel size in (28,30) or (28,80) the pixel data will be manipulated for display. In both cases the images are displayed with a warning symbol. When being saved after display the changes become permanent.

The MagicView 1000 is able to accept and interpret overlays described by group 60xx (see Table 21:).

Table 21: Overlay Attributes

Tag	Name	Module	Type	VR	VM
(60xx,0010)	Overlay Rows	Overlay Plane	1	US	1
(60xx,0011)	Overlay Columns	Overlay Plane	1	US	1
(60xx,0015)	Number of Frames in Overlay	Multi-Frame Overlay	1	IS	1
(60xx,0050)	Overlay Origin	Overlay Plane	1	SS	2
(60xx,0100)	Overlay Bits Allocated	Overlay Plane	1	US	1
(60xx,0102)	Overlay Bit Position	Overlay Plane	1	US	1
(60xx,3000)	Overlay Data	Overlay Plane	1C	OW	1

The overlay data to be displayed can be taken either from (60xx,3000) or from (7fe0,0010). When creating Overlay data the MagicView 1000 writes those data into (60xx,3000).

The DICOM MagicView 1000 Receiver DRCV uses the following return codes:

- **Refused (A700):**
This error status indicates a lack of Resources (e.g. not enough disk space) on the DICOM Interface Queues.
- **Error (A900 or C000):**
An error occurred while processing the image. The image might not be stored and the association is aborted.
- **Success(0000):**
In the event of a successful C-STORE operation, the image has been successfully stored.

In case of a return code 'Refused' or 'Error' the association is aborted.

2.3.2.4 Restrictions for 3D postprocessing

The following restrictions apply for 3D postprocessing:

- with respect to modality:

Table 22: Supported modalities for 3D postprocessing

Modality: (0008/0060)	SOP Class UID: (0008/0016)
CT	1.2.840.10008.5.1.4.1.1.2
MR	1.2.840.10008.5.1.4.1.1.4

- with respect to pixel formats: All pixel formats which can be converted into those ones listed below (see table 17), may be used:

Table 23: Supported pixel formats for 3D postprocessing

Pixel Representation: (0028/0103)	Samples per Pixel: (0028/0002)	Photometric Interpretation: (0028/0004)	Planar Configuration: (0028/0006)	Bits Allocated: (0028/0100)	Bits Stored: (0028/0101)	High Bit: (0028/0102)
0000	1	MONOCHROME1	n.a.	16	12 >= x > 9	11 >= x > 8
0000	1	MONOCHROME2	n.a.	16	12 >= x > 9	11 >= x > 8

- with respect to minimal set of header attributes required for 3D postprocessing:

Table 24: Attributes for 3D postprocessing

Description	Tag	Remark
Image Position (Patient)	(0020/0032)	
Image Orientation (Patient)	(0020/0037)	

Table 24: Attributes for 3D postprocessing

Description	Tag	Remark
Frame of Reference UID	(0020/0052)	
Rows	(0028/0010)	Only the following formats are supported: 128x128, 256x256, 512x512, 1024x1024
Columns	(0028/0020)	
Pixel Spacing	(0028/0030)	Non square pixel spacing is not supported.
Slice Thickness	(0018/0050)	

2.3.2.5 Restrictions for Image Composition

The following restrictions apply for Image Composition:

- with respect to SOP Classes:

Table 25: Supported SOP Classes for Image Composition

SOP Class UID: (0008/0016)
1.2.840.10008.5.1.4.1.1.12.1
1.2.840.10008.5.1.4.1.1.12.2
1.2.840.10008.5.1.4.1.1.12.3
1.2.840.10008.5.1.4.1.1.1
1.2.840.10008.5.1.4.1.1.1.1
1.2.840.10008.5.1.4.1.1.1.1

- with respect to modality:

Table 26: Supported modalities for Image Composition

Modality: (0008/0060)
CR
DR
DS
RF
DF
DX
XA

- with respect to pixel formats: All pixel formats which can be converted into those ones listed below(see table 22), may be used:

Table 27: Supported pixel formats for Image Composition

Pixel Representation: (0028/ 0103)	Samples per Pixel: (0028/ 0002)	Photometric Interpretation: (0028/ 0004)	Planar Configuration: (0028/ 0006)	Bits Allocated: (0028/ 0100)	Bits Stored: (0028/ 0101)	High Bit: (0028/ 0102)
0000	1	MONOCHROME1	n.a.	16	12 >= x > 9	11 >= x > 8
0000	1	MONOCHROME2	n.a.	16	12 >= x > 9	11 >= x > 8

The images are displayed without overlays or shutter.

2.3.3 Real-World Activity - Receive Query Request from a Remote Node

2.3.3.1 Associated Real-World Activity - respond to find request

The associated Real-World activity is a C-Find request received by the daemon process DQRY. After accepting an association from a remote DICOM AE, the DQRY process receives the query requests via the open association and queries the database. For each match a result message is sent to the requesting remote node.

2.3.3.2 Accepted Presentation Contexts

The Siemens MagicView 1000 will accept Presentation Contexts as shown in the following tables.

Table 28: Query SCP Presentation Contexts of MagicView 1000

Presentation Context Table					
Abstract Syntax		Transfer Syntax		Role	Extended Negotiation
Name	UID	Name List	UID List		
Patient Root Query/ Retrieve Information Model - FIND	1.2.840.10008.5.1.4.1.2.1.1	DICOM Implicit VR Little Endian Transfer Syntax	1.2.840.10008.1.2	SCP	None
		DICOM Explicit VR Big Endian Transfer Syntax,	1.2.840.10008.1.2.2		
		DICOM Explicit VR Little Endian Transfer Syntax	1.2.840.10008.1.2.1		

Study Root Query/ Retrieve Information Model - FIND	1.2.840.10008.5. 1.4.1.2.2.1	DICOM Implicit VR Little Endian Transfer Syntax DICOM Explicit VR Big Endian Transfer Syntax, DICOM Explicit VR Little Endian Transfer Syntax	1.2.840.10008.1.2 1.2.840.10008.1.2.2 1.2.840.10008.1.2.1	SCP	None
Patient/Study Only Query/ Retrieve Information Model - FIND	1.2.840.10008.5. 1.4.1.2.3.1	DICOM Implicit VR Litte Endian Transfer Syntax DICOM Explicit VR Big Endian Transfer Syntax, DICOM Explicit VR Little Endian Transfer Syntax	1.2.840.10008.1.2 1.2.840.10008.1.2.2 1.2.840.10008.1.2.1	SCP	None

2.3.3.3 SOP Specific Conformance Statement

- Relational Queries are supported.
- Priority processing is not supported.
- The query matching for patient name is case sensitive.
(Can be configured to case insensitive, see 5.2)
- The DICOM MagicView 1000 Query Provider DQRY returns one of the following status codes:
 - Success (0000):
Matching is complete
 - Pending (FF00):
Matches are continuing.
 - Pending (FF01):
Matches are continuing. Warning that one or more Optional Keys was not supported for existence of this Identifier.
 - Failed(A900):
Identifier does not match SOP Class
 - Refused (A700):
Out of Resources (0000,0902) Match overflow(default limit 500 matches)
 - Failed (C001):
Unable to process (special (0000,0902) no license)
 - Cancel (FE00)
- The Patient ID is the unique attribute tag at patient level in the DICOM Query Model. The hierarchical search method requires unique Patient IDs in the database. If the database does not support unique Patient IDs, the Service Class User should use the relational query method or the Study Root Query / Retrieve Model: this enables the user to take the Patient Name **and** Patient ID to select studies.

2.3.3.3.1 Patient Root C-Find SOP Class Specific Conformance Statement

R = required, U = unique, O = optional

Table 29: Supported Patient level attributes

Description	Tag	Type
Patient's Name	(0010,0010)	R
Patient ID	(0010,0020)	U
Patient's Birth Date	(0010,0030)	O
Patient's Sex	(0010,0040)	O
Other Patient IDs	(0010,1000)	O

Table 30: Supported Study level attributes

Description	Tag	Type
Study Date	(0008,0020)	R
Study Time	(0008,0030)	R
Accession Number	(0008,0050)	R
Study ID	(0020,0010)	R
Study Instance UID	(0020,000D)	U
Referring Physician's Name	(0008,0090)	O
Study Description	(0008,1030)	O
Name of Physician(s) Reading Study	(0008,1060)	O
Number of Study Related Images	(0020,1208)	O

Table 31: Supported Series level attributes

Description	Tag	Type
Modality	(0008,0060)	R
Series Number	(0020,0011)	R
Series Instance UID	(0020,000E)	U
Body Part Examined	(0018,0015)	O
Requested Procedure ID	(0040,1001)	O

The attribute Number Of Series Related Instances (20,1209) is not supported. The Requested Procedure ID may or may not be part of the Request Attributes Sequence (40,275) in the C-

Find request dqry receives. In the C-Find response it will always be encoded in the Request Attributes Sequence.

Table 32: Supported Image level attributes

Description	Tag	Type
Image Number	(0020,0013)	R
SOP Instance UID	(0008,0018)	U
Image Date	(0008,0023)	O
Image Time	(0008,0033)	O

2.3.3.3.2 Study Root C-Find SOP Class Specific Conformance Statement

Table 33: Supported Study level attributes

Description	Tag	Type
Study Date	(0008,0020)	R
Study Time	(0008,0030)	R
Accession Number	(0008,0050)	R
Patient's Name	(0010,0010)	R
Patient ID	(0010,0020)	R
Other Patient IDs	(0010,1000)	O
Study ID	(0020,0010)	R
Study Instance UID	(0020,000D)	U
Referring Physician's Name	(0008,0090)	O
Study Description	(0008,1030)	O
Name of Physician(s) Reading Study	(0008,1060)	O
Patient's Birth Date	(0010,0030)	O
Patient's Sex	(0010,0040)	O
Number of Study Related Images	(0020,1208)	O

- The same Series level attributes as in the Patient Root C-Find SOP class are supported.
- The same Image level attributes as in the Patient Root C-Find SOP class are supported.

2.3.3.3.3 Patient/Study Only C-Find SOP Class Specific Conformance Statement

- The same Patient level attributes as in the Patient Root C-Find SOP class are supported.
- The same Study level attributes as in the Patient Root C-Find SOP class are supported.

2.3.4 Real-World Activity - Receive Transfer Request from a Remote Node

2.3.4.1 Associated Real-World Activity - initiate image transfer

The associated Real-World activity is a C-Move request received by the internal daemon process DQRY. After accepting an association from a remote DICOM AE, the DQRY process receives the move request via the open association and queries the database. The requested images are sent to the requested remote node.

2.3.4.2 Accepted Presentation Contexts

The Siemens MagicView 1000 will accept Presentation Contexts as shown in the following table.

Table 34: Retrieve SCP Presentation Contexts of MagicView 1000

Presentation Context Table					
Abstract Syntax		Transfer Syntax		Role	Extended Negotiation
Name	UID	Name List	UID List		
Patient Root Query/ Retrieve Information Model - MOVE	1.2.840.10008.5.1.4.1.2.1.2	DICOM Implicit VR Little Endian Transfer Syntax	1.2.840.10008.1.2	SCP	None
		DICOM Explicit VR Big Endian Transfer Syntax,	1.2.840.10008.1.2.2		
		DICOM Explicit VR Little Endian Transfer Syntax	1.2.840.10008.1.2.1		
Study Root Query/ Retrieve Information Model - MOVE	1.2.840.10008.5.1.4.1.2.2.2	DICOM Implicit VR Little Endian Transfer Syntax	1.2.840.10008.1.2	SCP	None
		DICOM Explicit VR Big Endian Transfer Syntax,	1.2.840.10008.1.2.2		
		DICOM Explicit VR Little Endian Transfer Syntax	1.2.840.10008.1.2.1		
Patient/Study Only Query/ Retrieve Information Model - MOVE	1.2.840.10008.5.1.4.1.2.3.2	DICOM Implicit VR Little Endian Transfer Syntax	1.2.840.10008.1.2	SCP	None
		DICOM Explicit VR Big Endian Transfer Syntax,	1.2.840.10008.1.2.2		
		DICOM Explicit VR Little Endian Transfer Syntax	1.2.840.10008.1.2.1		

2.3.4.3 SOP Specific Conformance statement for SOP class C-Store

DQRY initiates C-Store sub-operations using DICOM Implicit VR Little Endian Transfer Syntax.

2.3.5 Real-World Activity - Receive Storage Commitment Request from a Remote Node

2.3.5.1 Associated Real-World Activity - Response to Storage Commitment Request

The associated Real-World activity is a storage commitment request received by the internal daemon process DNES. After accepting an association from a remote DICOM Application Entity, DNES waits for receiving storage commitment requests. DNES queries the internal database for the SOP instances referenced by the storage commitment request.

The MagicView provides only short term archiving. The existence of the UID in the database ensures that the images are stored on the MagicView. The MagicView will ensure that those SOP instances will be forwarded to a long term archive. Nevertheless, privileged users may decide that some of the SOP instances may not be sent to a long term archive and may be deleted from the MagicView without being long term archived.

2.3.5.2 Accepted presentation Contexts

The Siemens MagicView will accept Presentation Contexts as shown in the following table.

Table 35: Storage Commitment Push Model SCP Presentation Contexts of MagicView 1000

Presentation Context Table					
Abstract Syntax		Transfer Syntax		Role	Extended Negotiation
Name	UID	Name List	UID List		
Storage Commitment Push Model	1.2.840.10008.1.20.1.1	DICOM Implicit VR Little Endian Transfer Syntax	1.2.840.10008.1.2	SCP	None
		DICOM Explicit VR Big Endian Transfer Syntax	1.2.840.10008.1.2.2		
		DICOM Explicit VR Little Endian Transfer Syntax	1.2.840.10008.1.2.1		

2.3.5.3 SOP specific Conformance Statement for SOP Class Storage Commitment Push Model SCP

2.3.5.3.1 Operations

Upon receipt of the N-Action request DNES returns, via the N-Action response primitive, one of the following N-Action Response Status Codes applicable to the associated request.

Return Status Codes:

- processing failure (0900)
- success (0000)

A success status conveys that DNES has successfully received the request. A failure status conveys that DNES is not processing the request.

The attributes Referenced Study Component Sequence (0008,1111), Storage Media File Set ID (0088,0130) and Storage Media File Set UID (0088,0140) are not supported.

2.3.5.3.2 Notifications

After querying the database for the SOP Instances referenced by the Storage Commitment request, DNES generates an N-EVENT-REPORT request according to the result of the query. The N-EVENT-REPORT request includes the same Transaction UID as contained in the initiating N-Action request. Afterwards the Transaction UID is no longer valid.

Furthermore, the N-EVENT-REPORT request contains the Retrieve AE Title (0008,0054) that can be used by the Storage Commitment SCU to query and/or retrieve the SOP Instances referenced by the Storage Commitment request. The Retrieve AE Title will only be temporarily valid, since the MagicView will delete images off its local store after a while.

Per default DNES opens a new association for the N-EVENT-REPORT request. It can also be configured, though, that DNES tries to use the same association as the N-Action request and only opens a new association in case of failure (see 5.2).

The attributes Referenced Study Component Sequence (0008,1111), Storage Media File Set ID (0088,0130) and Storage Media File Set UID (0088,0140) are not supported in the N-EVENT-REPORT request.

2.3.6 Presentation Context Acceptance Criterion

The Siemens MagicView 1000 will accept any number of retrieve SOP classes that are listed above. There is no limit on the number of presentation contexts accepted. In the event that the Siemens MagicView 1000 runs out of resources, it will reject the association request.

2.3.7 Transfer Syntax Selection Policies

The Siemens MagicView currently supports the Implicit VR Little Endian, the Explicit VR Little Endian, Explicit VR Big Endian JPEG Baseline (Process 1) Lossy, JPEG Extended (Process 2 und 4) Lossy and JPEG Lossless, Non-Hierarchical (Process 14) transfer syntax (detailed description see presentation context tables).

The transfer syntax priority order for the Storage Class Provider is: JPEG Baseline (Process 1) Lossy, JPEG Extended (Process 2 and 4), JPEG Lossless, Explicit VR Big Endian, Explicit VR Little Endian and Implicit VR Little Endian.

The transfer syntax priority order for the Storage Commitment Provider and the Query/Retrieve Provider is: Explicit VR Big Endian, Explicit VR Little Endian and Implicit VR Little Endian. By default the Service Class User will propose transfersyntax according to their configuration file or in case of FOS the user interface enables a MagicView user to select a transfer syntax. JPEG restrictions are listed in chapter 2.2.1.3 SOP Specific Conformance Statement.

3 Communication Profiles

3.1 Supported Communication Stacks

Siemens MagicView 1000 provides DICOM TCP/IP Network Communication Support as defined in Part 8 of the DICOM Standard.

3.1.1 OSI Stack

not yet supported.

3.1.2 TCP/IP Stack

Siemens MagicView 1000 uses the TCP/IP stack from the SUN SOLARIS system upon which it executes.

3.1.2.1 Physical Media Support

Siemens MagicView 1000 is independent of the physical medium over which TCP/IP executes. This feature is inherent in the SUN SOLARIS operating system used on the MagicView.

3.1.3 Point-to-Point Stack

not supported.

4 Extensions/Privatizations/Specializations

4.1 Standard Extended/ Specialized/Private SOPs

None.

4.2 Private Transfer Syntaxes

None.

5 Configuration

5.1 AE Title / Presentation Address Mapping

The Siemens MagicView 1000 maps Application Entity Titles to host name and port number via an internal configuration method. The IP address for the host name is determined using standard UNIX system calls.

For each DICOM MagicView 1000 **default** unique Application Entity Titles are assigned using the following mechanism:

Each Application Entity Title starts with a unique 10 character string assigned to a DICOM MagicView node. This string is also used as the first 10 characters of each PACSnet Logical Address (PLA) of the SIENET processes on the Siemens MagicView 1000. An example of such a string is '049SA1DC39'.

If <AEroot> describes such a 10 character unique string assigned to this specific DICOM MagicView, the DICOM Application Entity title of DRCV and FOS (Storage AE Title):

<AEroot>DRSP portnumber 50082

The DICOM Application Entity Title of DNES (Storage Commitment) is:

<AEroot>DNES port number: 60034

The DICOM Application Entity Title of the DQRY and DQUS (Query/Retrieve AE Title) is:

<AEroot>DQRY portnumber 50089

The DICOM Application Entity Title of the Printer AET is:

<AEroot>DBPR portnumber 60036

The portnumber and AE Titles of each process can be changed with the SIENET Install Tool. The portnumber and AET from DRCV and DQRY must be different.

5.2 Configurable Parameters

The Application Entity Titles, host names and port numbers are configurable values.

The following parameters can be configured with the SIENET Installation Tool. The Installation Tool also uses some default parameters:

- max PDU size set to 28672 Bytes
- no patient name normalization
- time-out for accepting/rejecting an association request: 240 sec
- time-out for responding to an association open/close request: 240 sec
- time-out for accepting a message over the network: 240 sec
- time-out for a network connect to be accepted: 15 sec
- time-out for waiting for data between packets: 60 sec
- number of folder send retries: 3
- time between folder send retries: 10 min

-
- folder merge timeout for DICOM receiver: 0 sec (each image is a new folder)
 - maximum number of parallel image transfers to the same DICOM node: 2
 - maximum number of parallel image transfers: 5

Further parameters can be configured in project specific solutions:

- Case-insensitive matching of patient name
- No new association for DICOM Storage Commitment N-Event Report requests
- Time-outs for DICOM Basic Print see 2.2.4.6
- Time-outs for DICOM Query/Retrieve see 2.2.2.3 and 2.2.3.3
- Display of studies in query matches list see 2.2.2.3
- Relational Query Model see 2.2.2.3

6 Support of Extended Character Sets

The Siemens DICOM application supports the ISO 8859 Latin 1(ISO-IR 100) character set.

Index

I

Implementation	9
Implementation Model	9
IOD	8

P

PLA	8
---------------	---

S

SCP	8
SCU	8

U

UID	8
---------------	---

Copyright © Siemens AG Medical Solutions, Health Services, 2001.
All rights reserved. For internal use only.
Alle Rechte vorbehalten. Nur für internen Gebrauch.

Siemens AG Medical Solutions, Health Services
Henkestr. 127, D-91052 Erlangen

This document has been created using Template "DICOM Conformance Statement", Rev. 0.1,
07-May-2001

Für dieses Dokument wurde Template "DICOM Conformance Statement", Rev. 0.1, 07-May-
2001 verwendet.

Copyright © Siemens AG Medical Solutions, Health Services, 2001. All rights reserved. For
internal use only.

Alle Rechte vorbehalten. Nur für internen Gebrauch.

Siemens AG Medical Solutions, Health Services
Henkestr. 127, D-91052 Erlangen