

Siemens Medical Solutions USA, Inc., Ultrasound Group

Acuson Cypress DICOM Conformance Statement



Table of Contents

1.0	Purpose.....	4
2.0	Scope.....	4
3.0	Definitions.....	4
4.0	Implementation Model.....	5
4.1	Application Data Flow Diagrams	6
4.1.1	Verification	7
4.1.2	Image Export.....	7
4.1.3	Storage Commitment	8
4.1.4	Modality Worklist.....	8
4.1.5	Removable Media Storage.....	10
4.2	AE Functional Descriptions.....	10
4.2.1	Verification Real-World Activities.....	10
4.2.2	Store Real-World Activities.....	10
4.2.3	Storage Commitment Real-World Activities.....	11
4.2.4	Modality Worklist Real-World Activities.....	11
4.2.5	Removable Media Storage Real-World Activities	11
5.0	AE Specifications.....	11
5.1	Acuson Cypress AE Specification.....	11
5.1.1	Association Establishment Policies	12
5.1.1.1	General.....	12
5.1.1.2	Association Establishment Order.....	12
5.1.1.3	Asynchronous Nature.....	12
5.1.1.4	Implementation Identifying Information	12
5.1.2	Association Initiation by Real-World Activities.....	12
5.1.2.1	Real World Activity – Verification.....	12
5.1.2.2	Real World Activity – Store	13
5.1.2.3	Real-World Activity – Storage Commitment	19
5.1.2.4	Real World Activity – Modality Worklist	22
6.0	Removable Interchange Media Specifications.....	24
6.1	Supported SOP Classes.....	25
6.2	Proposed Interchange Media Transfer Syntaxes.....	25
6.3	Physical Storage Media and Format	25
7.0	Communication Profiles	26
7.1	TCP/IP Stack Supported	26
7.1.1	Physical Media Supported	26
7.1.2	Chapter Extensions/Specializations/Privatizations.....	26
8.0	Configuration	26
8.1	Network Identification.....	26
8.2	Cypress DICOM Information	27
8.3	DICOM Server Information.....	27
8.4	Modality Worklist Sever Information.....	27
8.5	Support of Extended Character Sets	28

List Of Tables

Table 1 Acronyms and Definitions	5
Table 2 Displayed Worklist Return Values	9
Table 3 Cypress New Patient Screen Parameters Populated From Worklist Return Values	10
Table 4 Supported SOP Classes.....	11
Table 5 Verification Presentation Context.....	13
Table 6 Store Presentation Context.....	13
Table 7 Supported SOP Classes.....	14
Table 8 US Image IOD Attributes used.....	16
Table 9 Ultrasound Multi-Frame Image IOD Attributes used.....	19
Table 10 Storage Commitment Request Presentation Context.....	20
Table 11 Supported SOP Classes.....	20
Table 12 Storage Commitment Request Attributes	20
Table 13 Storage Commitment Response Attributes.....	22
Table 14 Modality Worklist Presentation Context	22
Table 15 Supported SOP Classes.....	23
Table 16 Modality Worklist Query Attributes.....	24
Table 17 Media Storage SOP Classes.....	25
Table 18 Proposed Transfer Syntaxes for Interchange Media.....	25

List Of Figures

Figure 1 Implementation Model	6
Figure 2 Verification Model	7
Figure 3 Store Model	7
Figure 4 Storage Commitment Model	8
Figure 5 Modality Worklist Model.....	9

1.0 Purpose

This document describes the conformance to the ACR-NEMA DICOM 3.0 Standard by the Acuson® Cypress ultrasound system software version 20.0 from Siemens Medical Solutions, Inc. Ultrasound Division. It shall establish the conformance specifications for this system only, and does not apply to other products offered by Siemens Medical Solutions, or its affiliates. The Acuson Cypress system is a device that generates ultrasound images that can be sent using DICOM standard protocols and definitions to other DICOM compliant devices that support the SOP classes defined in Table 4.

2.0 Scope

The DICOM standard provides a well-defined set of structures and protocols that allow interoperability of a wide variety of medical imaging devices. The Acuson Cypress system provides support for essential services related to ultrasound scanning and connectivity to DICOM compliant devices. Acuson Cypress systems will not support all features supported by the DICOM standard. This document clearly states the DICOM services and data classes that are supported by the applications included with the Acuson Cypress. The intent of this document is to allow users and other vendors who also conform to the DICOM standard to exchange information within the specific context of those elements of the DICOM standard that Acuson Cypress system supports.

This document is written with respect to the adopted portions of the DICOM standard, Version 3. The following sections of this document follow the outline specified in the DICOM Standard NEMA publication PS3.2 [1].

3.0 Definitions

Acronym or Abbreviation	Definition
ACR-NEMA	American College of Radiology - National Electrical Manufacturer's Association
AE	Application Entity
Conformance Statement	A formal statement associated with a specific implementation of the DICOM Standard. It specifies the Service Classes, Information Objects, Communications Protocols and Media Storage Application Profiles supported by the implementation
DICOM 3.0	Digital Imaging and Communications in Medicine, Version 3.0.
DIMSE	DICOM Message Service Element
ELE	Explicit Little Endian transfer syntax
ILE	Implicit Little Endian transfer syntax
C-STORE	Composite Store
FSC	Interchange Media File Set Creator

FSU	Interchange Media File Set Updater
Ethernet	Network topology devised in 1976 by DIX (DEC/Intel/Xerox) which is the most common in practice today.
HIS	Hospital Information System
IOD	Information Object Definition
MOD	Magneto Optical Disk
MWL	Modality Worklist
PACS	Picture Archiving and Communications Systems
PDU	Protocol Data Unit
RIS	Radiology Information System
RWA	Real-World Activity
SCP	Service Class Provider
SCU	Service Class User
SOP	Service-Object Pair
TM	Ultrasound Time Motion Modes – M-Mode, and Spectral Doppler Mode
UID	Unique identifier
US	Ultrasound

Table 1 Acronyms and Definitions

4.0 Implementation Model

All Cypress systems come standard with the ability to store images on a Magneto-Optical Disk. All network functions (Verification, Network Store, Storage Commitment, and Modality Worklist) are available only if the Cypress has the optional Networking package installed.

Acuson Cypress system users can store images directly on the system hard drive. Images can also be transferred to DICOM workstations and archive servers on a network. Storage Commitment can be used to insure that patient images and data are safely committed on a PACS. The system is capable of querying a HIS/RIS, using DICOM Modality Worklist, for a list of scheduled patient procedures.

Acuson Cypress system real world activities are indicated by “Real World Activity” name while “Cypress AE” indicates the invoked Application Entity. Similarly, the activities associated with service providers are indicated as “Real World Service Activity.”

4.1 Application Data Flow Diagrams

Figure 1 illustrates the Acuson Cypress system's Application Entity (AE), which is shown in the box. Relationships between users invoked activities (in the circles at the left of the AE) and the associated real-world activities provided by DICOM service providers (in the circles on the right side of the diagram) are shown.

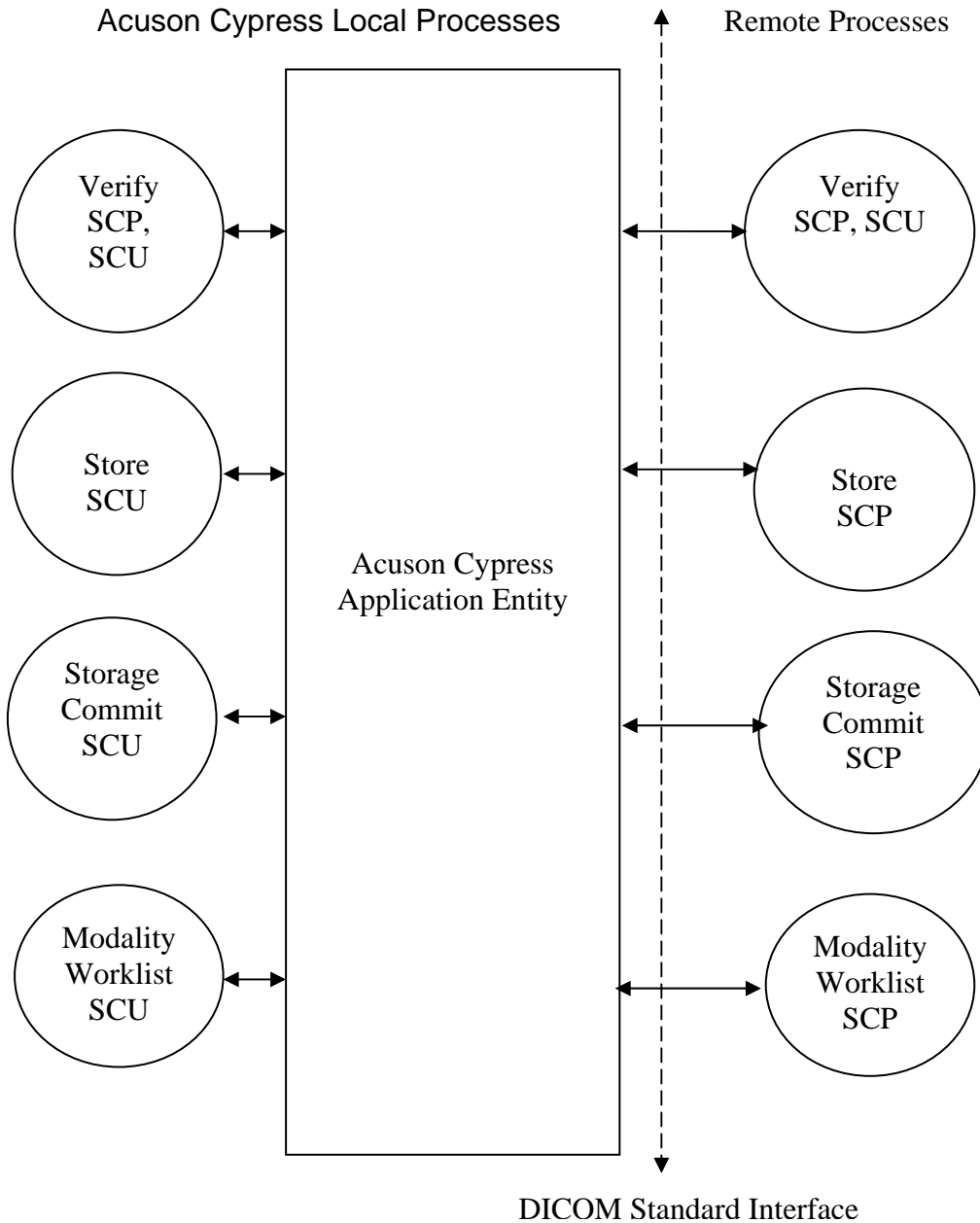

Figure 1 Implementation Model

4.1.1 Verification

Verification is available in the DICOM Server and Modality Worklist Setup pages. Verification can be used to send a DICOM verification request (C-ECHO) to a remote Application Entity (AE) and will listen for a response. Verification on the Cypress can be performed as an SCU or an SCP.

When the Verification SCU is invoked, the following messages are returned to the user:

- Verify Successful
- Verify Failure

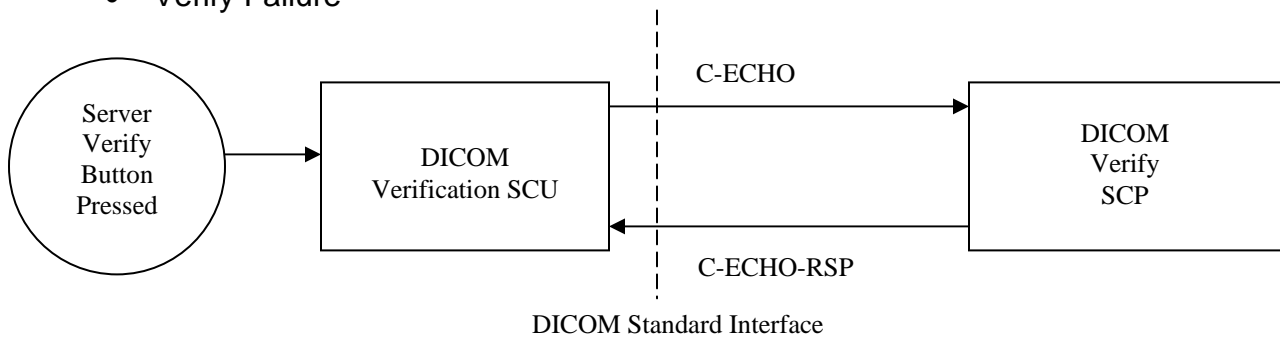

Figure 2 Verification Model

4.1.2 Image Export

Image Export allows the user to export Cypress single frame and multi-frame ultrasound images to a networked DICOM archive server, which supports the Storage service class as an SCP. The Cypress system acts as SCU for the C-STORE DICOM network service. The storage operation is initiated from the Cypress Send Page.

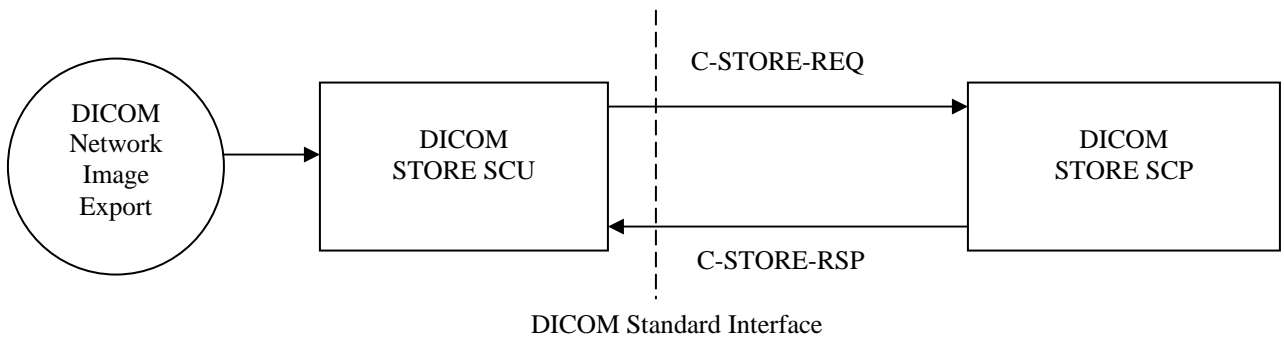

Figure 3 Store Model

4.1.3 Storage Commitment

In order for the Cypress to send the Storage Commitment N-ACTION-REQ message, the Server must have the Storage Commitment Server Name selected on the Cypress DICOM Server Setup Page.

If enabled, DICOM Storage Commitment is embedded in the successful completion of a study store to a DICOM Store SCP. It is dynamically negotiated when all images have been successfully stored to a server.

Cypress uses the DICOM Storage Commitment Push Model to inform the server when all stores for a study have been completed. The Storage Commitment SCU uses the N-ACTION-REQ primitive to make a request to the SCP for safekeeping of a set of SOP instances (eg: Ultrasound images).

The Cypress Storage Commitment SCU also performs a role reversal and becomes the SCP for the N-EVENT-REPORT-REQ primitives received from the original SCP (now an SCU).

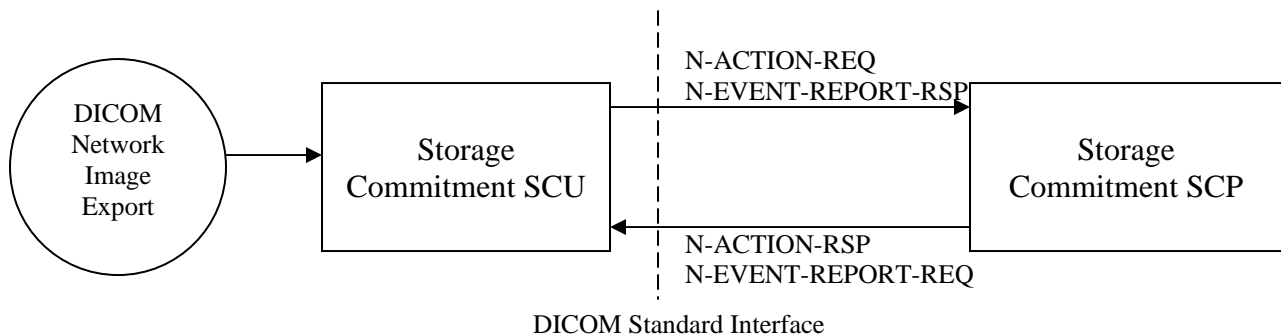

Figure 4 Storage Commitment Model

4.1.4 Modality Worklist

Patient registration can be automated by using the 'Worklist' Real World Activity. Pressing the 'Patient' key on the keyboard displays the current list of patients and studies stored on the system. Pressing the 'Worklist' button on the patient data display screen invokes the Worklist Query screen.

Pressing the 'Query' button will attempt to find all matching patients using the information from the Worklist Query screen. Patient name fields that are partially filled or empty will be treated as though an implicit wildcard was appended at the end of each field. ID and Accession number will be exact match only. If no matches are found, a message will be presented to the operator indicating so. If one or more matching patients are found, a pick list of patient exams will be presented to the user to select from. Each of the fields can be sorted in ascending and descending order. The list will be limited to a number of preset entries. If more than this number of matching records is found in the query, the search will terminate and the user will be notified. The search list criteria will contain:

- Patient Name
- Patient ID
- Accession Number
- Procedure ID
- Scheduled Station AE Title
- Exam Start Date Range
- US/All Modality

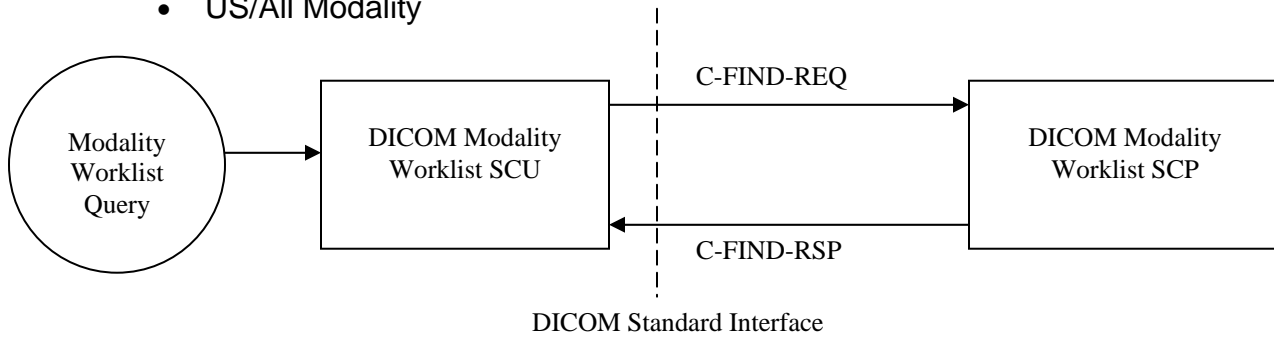

Figure 5 Modality Worklist Model

The following data fields will be populated on the worklist screen for each return:

Attribute Name	Tag
Patient Name	(0010, 0010)
Patient ID	(0010, 0020)
Patient Birth Date	(0010, 0030)
Patient Sex	(0010, 0040)
Accession Number	(0008, 0050)
Exam Date	(0040, 0002)
Modality	(0008, 0060)

Table 2 Displayed Worklist Return Values

The user will have the option to select a patient exam or cancel the operation. An exam can be selected from the picklist by double clicking on it or by pressing the Create button. By doing so, all MWL data received for the selected study will be displayed in the MWL Study Details Dialog. The user can populate the New Patient Dialog by pressing the OK button, or return to the MWL Query Dialog by pressing the Cancel button.

The following data fields will be populated on the New Patient Data Screen:

Attribute Name	Tag
Patient Name	(0010, 0010)
Patient ID	(0010, 0020)
Patient Birth Date	(0010, 0030)
Patient Sex	(0010, 0040)
Height	(0010, 1020)

Weight	(0010, 1030)
Indication	(0080, 1080)
Accession Number	(0008, 0050)

Table 3 Cypress New Patient Screen Parameters Populated From Worklist Return Values

Once a Worklist query is initiated, a “Worklist Query In Progress” dialog will be presented to the user. The user will only have one option, “CANCEL,” which will abort the query operation.

4.1.5 Removable Media Storage

The Cypress can perform DICOM C-STORE operations to its standard on-board 90mm Magneto Optical disk drive. The Cypress performs the File Set Creator and File Set Updater Roles for MO disks. The ACUSON Cypress has the capability to create the Basic Directory IOD (DICOMDIR) on the local Magneto-Optical disk.

4.2 AE Functional Descriptions

4.2.1 Verification Real-World Activities

The Acuson Cypress application entity performs the Verification Service Class as an SCU and SCP allowing the operator to verify the ability of an application on a remote device to receive DICOM messages and allowing the operator of a remote DICOM device to verify the Acuson Cypress system’s ability to receive DICOM messages. (C-ECHO DIMSE)

4.2.2 Store Real-World Activities

The Acuson Cypress Application Entity (AE) performs all of the functions to transmit ultrasound images and associated data to network servers and / or workstations. The Acuson Cypress AE supports the Ultrasound Image and Ultrasound Multi-Frame Image storage SOP classes as an SCU. Note that the following SOP Classes are **not supported** by the Acuson Cypress:

- Retired Ultrasound Image (1.2.840.10008.5.1.4.1.1.6)
- Retired Ultrasound Multi-Frame Image (1.2.840.10008.5.1.4.1.1.3)
- Secondary Capture (1.2.840.10008.5.1.4.1.1.7)

The Acuson Cypress AE initiates an association for C-STORE Requests to a C-STORE SCP when the user invokes a DICOM Store from the Send Page. The association may be used to store multiple images, clips, and report images contained within a single study.

4.2.3 Storage Commitment Real-World Activities

The Cypress AE supports the Storage Commitment Push Model SOP class to inform servers when all the store operations for a study have been completed, if the Storage Commitment SCP has been properly configured on the Cypress (see section 4.1.3). The Storage Commitment SCU uses the N-ACTION-REQ primitive to request safekeeping of a set of SOP Instances (Ultrasound Images). The Storage Commitment SCU also processes the N-EVENT-REPORT primitives that are received from the SCP indicating 'successful' or 'non-successful' commitment status.

4.2.4 Modality Worklist Real-World Activities

The Acuson Cypress AE supports the DICOM Basic Worklist Management Service as an SCU. The Modality Worklist SCU uses the C-FIND-REQ primitive to query the worklist. The AE initiates an association to the active Worklist server when a Worklist query is selected (via the "Query" button). The association is closed upon the completion of each query. A preset number of maximum matching results are accepted, at which point, the Acuson Cypress AE issues a C-FIND-CANCEL request.

4.2.5 Removable Media Storage Real-World Activities

The Acuson Cypress AE supports DICOM Store to Media. The supported media are 90mm (3.5 inch) Magneto Optical Disks, with capacities of 128MB, 230MB, 540MB, 640MB, and 1300 MB (1.3 GB). A DICOMDIR is written to the root directory of the media at the completion of each operation.

5.0 AE Specifications

The following specifications apply to the Acuson Cypress AE as depicted in Figure 1.

5.1 Acuson Cypress AE Specification

The Acuson Cypress AE provides conformance to the following DICOM Service SOP Classes as an SCU. Additionally, the Acuson Cypress AE provides conformance to Verification SOP Class as SCP.

Service SOP Class Name	SOP Class UID
Verification	1.2.840.10008.1.1
Ultrasound Image Storage	1.2.840.10008.5.1.4.1.1.6.1
Ultrasound Multi-Frame Image Storage	1.2.840.10008.5.1.4.1.1.3.1
Storage Commitment	1.2.840.10008.1.20.1
Modality Worklist Information Model C-Find	1.2.840.10008.5.1.4.31

Table 4 Supported SOP Classes

5.1.1 Association Establishment Policies**5.1.1.1 General**

The Acuson Cypress system utilizes TCP/IP. The Maximum Length PDU negotiation is included in all association establishment requests. The maximum length PDU size is configurable. This value must be greater than 1024, the default value is 4096.

5.1.1.2 Association Establishment Order

The Acuson Cypress initiates each C-Store Request serially, for each study transfer request being processed.

The Cypress negotiates Ultrasound Image and Ultrasound Multi-Frame Image sequentially.

5.1.1.3 Asynchronous Nature

All associations use the default synchronous mode of operation. Asynchronous Operations Window negotiations are not supported on the Acuson Cypress system.

5.1.1.4 Implementation Identifying Information

- Implementation Class UID: 1.2.840.113680.4.103 (see below)
- Implementation Version Name: 14.00

Siemens has provided registration for all Siemens Medical Systems Groups. The unique Class UID for the Acuson product is defined as: "1.2.840.113680"

Where the interpretation is:

1. = International Standards Organization (ISO)

2. = ANSI member body

840. = Country Code (United States)

113680 = ANSI Registered number assigned to Acuson products

5.1.2 Association Initiation by Real-World Activities**5.1.2.1 Real World Activity – Verification**

The Acuson Cypress is capable of supporting the Verification service class as an SCU or SCP. Verification can be initiated as a singular event from the DICOM Server or Modality Worklist Server set pages.

Proposed Presentation Context – Verification

The Acuson Cypress will propose Presentation Contexts as shown in Table 5.

Abstract Syntax		Transfer Syntax		Role	Extended Negotiation
Name	UID	Name List	UID List		
Verification	1.2.840.10008.1.1	Implicit VR Little Endian	1.2.840.10008.1.2	SCU/SCP	None
Verification	1.2.840.10008.1.1	Explicit VR Little Endian	1.2.840.10008.1.2.1	SCU/SCP	None

Table 5 Verification Presentation Context

5.1.2.2 Real World Activity – Store

When images are transferred from the hard disk to a DICOM Store SCP, the system establishes an association between the Cypress AE and the configured DICOM device (i.e. Network Archive Server, Workstation Server). The association may be used to store multiple images and clips and is closed when the study transfer is complete.

Proposed Presentation Context – Store

The following Presentation Contexts are presented to the SCP in an Associate request for DIMSE C-STORE storage services. The storage services utilize C-STORE services, as defined by the DICOM Standard. Table 6 represents all “Store” Real World Activities.

Abstract Syntax		Transfer Syntax		Role	Extended Negotiation
Name	UID	Name List	UID List		
Ultrasound Image Storage	1.2.840.10008.5.1.4.1.1.6.1	Lossy JPEG 8 Bit Image Compression	1.2.840.10008.1.2.4.50	SCU	None
Ultrasound Image Storage	1.2.840.10008.5.1.4.1.1.6.1	Run Length Encoded	1.2.840.10008.1.2.5	SCU	None
Ultrasound Image Storage	1.2.840.10008.5.1.4.1.1.6.1	DICOM Implicit VR Little Endian	1.2.840.10008.1.2	SCU	None
Ultrasound Image Storage	1.2.840.10008.5.1.4.1.1.6.1	DICOM Explicit VR Little Endian	1.2.840.10008.1.2.1	SCU	None
Ultrasound Multi-Frame Image Storage	1.2.840.10008.5.1.4.1.1.3.1	Lossy JPEG 8 Bit Image Compression	1.2.840.10008.1.2.4.50	SCU	None
Ultrasound Multi-Frame Image Storage	1.2.840.10008.5.1.4.1.1.3.1	Run Length Encoded	1.2.840.10008.1.2.5	SCU	None
Ultrasound Multi-Frame Image Storage	1.2.840.10008.5.1.4.1.1.3.1	DICOM Implicit VR Little Endian	1.2.840.10008.1.2	SCU	None
Ultrasound Multi-Frame Image Storage	1.2.840.10008.5.1.4.1.1.3.1	DICOM Explicit VR Little Endian	1.2.840.10008.1.2.1	SCU	None

Table 6 Store Presentation Context

The Acuson Cypress system always acts as an SCU and is the client in a client-server model.

SOP Specific Conformance to Storage Service SOP Classes

The Store Real World Activity provides standard conformance as an SCU for the following standard Storage Service Class SOP:

Service SOP Class Name	SOP Class UID	Conformance Level
Ultrasound Image Storage	1.2.840.10008.5.1.4.1.1.6.1	Standard
Ultrasound Multi-Frame Image Storage	1.2.840.10008.5.1.4.1.1.3.1	Standard

Table 7 Supported SOP Classes

This is accomplished using the DIMSE C-STORE Service. The SCU issues a service request with a SOP instance that meets the requirements of the desired ultrasound IOD.

The following table denotes the attributes included in the Ultrasound Image Object as implemented on the Acuson Cypress. Attributes not listed are not used.

Module	Attribute	Tag	Notes
Patient	Patient Name	(0010,0010)	From New Patient/Study Screen or MWL
	Patient ID	(0010,0020)	From New Patient/Study Screen or MWL
	Patient Birth Date	(0010,0030)	From New Patient/Study Screen or MWL
	Patient Sex	(0010,0040)	From New Patient/Study Screen or MWL
	Other Patient Ids	(0010,1000)	From MWL
	Other Patient Names	(0010,1001)	From MWL
	Patient Age	(0010,1010)	From MWL
	Patient Size	(0010,1020)	From New Patient/Study Screen or MWL
	Patient Weight	(0010,1030)	From New Patient/Study Screen or MWL
	Additional Patient History	(0010,21B0)	From MWL
	Patient Comment	(0010,4000)	Miscellaneous field from New Patient/Study screen
	Admitting Diagnosis Description	(0008,1080)	From Study Indication field on New Patient/Study Screen or MWL
	General Study	Study Instance UID	(0020,000D)
Study Date		(0008,0020)	Date of study creation or from MWL
Study Time		(0008,0030)	Time of study creation
Referring Physician's Name		(0008,0090)	From MWL
Study ID		(0020,0010)	Study Number
Accession Number		(0008,0050)	From New Patient/Study Screen or MWL
Study Description		(0008,1030)	From New Patient/Study Screen or MWL
Performing Physician Name		(0008,1050)	From MWL
Study Classification Module	Study Comments	(0032,4000)	From Patient Report
General Series	Modality	(0008,0060)	US
	Operator's Name	(0008,1070)	From New Patient/Study Screen or MWL
	Series Instance UID	(0020,000E)	Internally Generated or from MWL
	Series Number	(0020,0011)	Always 1

General Equipment	Manufacturer	(0008,0070)	Set to Acuson
	Institution Name	(0008,0080)	From New Patient/Study Screen
	Institution Address	(0008,0081)	From MWL
	Manufacturer's Model Name	(0008,1090)	Set to "Cypress"
	Device Serial Number	(0018,1000)	Set to system serial number
	Station Name	(0008,1010)	From MWL or Computer Name, if networking option installed
	Software Version	(0018,1020)	Set to 14.0
General Image	Image Date	(0008,0023)	Date of image creation
	Image Time	(0008,0033)	Time of image creation
	Image Number	(0020,0013)	Image number in study (1-n)
	Patient Orientation	(0020,0020)	Always a null string
	Image Comments	(0020,4000)	Either "Entire Study" or "Flagged Loops Only", based on transfer type selected on Send Page
Image Pixel	Samples Per Pixel	(0028,0002)	Compression Dependent: Uncompressed = 1 RLE Compressed = 1 JPEG Compressed = 3
	Rows	(0028,0010)	Set to 456 for full screen or TM output, 240 for ROI Size Stress Echo Study Output (non TM)
	Columns	(0028,0011)	Set to 576 for full screen or TM output, 320 for ROI Size Stress Echo Study Output (non TM)
	Bits Allocated	(0028,0100)	Always set to 8
	Bits Stored	(0028,0101)	Always set to 8
	High Bit	(0028,0102)	Always set to 7
	Pixel Data	(7FE0,0010)	
	Planar Configuration	(0028,0006)	Compression Dependent: Uncompressed – Not Used RLE Compressed – Not Used JPEG Compressed = 0
	Photometric Interpretation	(0028,0004)	Compression Dependent: Uncompressed – PALETTE_COLOR RLE Compressed – PALETTE_COLOR JPEG Compressed – YBR_FULL_422
	Pixel Representation	(0028,0103)	0, Pixel representation of unsigned integer
	Red Palette Color Lookup Table Descriptor	(0028,1101)	Used only with Uncompressed or RLE Compressed Image Output
	Green Palette Color Lookup Table Descriptor	(0028,1102)	Used only with Uncompressed or RLE Compressed Image Output
	Blue Palette Color Lookup Table Descriptor	(0028,1103)	Used only with Uncompressed or RLE Compressed Image Output
	Red Palette Color Lookup Table Data	(0028,1201)	Used only with Uncompressed or RLE Compressed Image Output
	Green Palette Color Lookup Table Data	(0028,1202)	Used only with Uncompressed or RLE Compressed Image Output
	Blue Palette Color Lookup Table Data	(0028,1203)	Used only with Uncompressed or RLE Compressed Image Output
SOP Common	Specific Character Set	(0008,0005)	From MWL
	SOP Class UID	(0008,0016)	1.2.840.10008.5.1.4.1.1.6.1
	SOP Instance UID	(0008,0018)	Internally generated

	Specific Character Set	(0008,0005)	
US Region Calibration	Sequence of Ultrasound Regions	(0018,6011)	One for each US region displayed
	>Region Location Min x0	(0018,6018)	
	>Region Location Min y0	(0018,601A)	
	>Region Location Max x1	(0018,601C)	
	>Region Location Max y1	(0018,601E)	
	>Physical Units X Direction	(0018,6024)	
	>Physical Units Y Direction	(0018,6026)	
	>Physical Delta X	(0018,602C)	
	>Physical Delta Y	(0018,602E)	
	>Reference Pixel x0	(0018,6020)	
	>Reference Pixel y0	(0018,6022)	
	>Ref. Pixel Physical Value X	(0018,6028)	
	>Ref Pixel Physical Value Y	(0018,602A)	
	>Region Spatial Format	(0018,6012)	
	>Region Data Type	(0018,6014)	
	>Region Flags	(0018,6016)	
US Image Module	Heart Rate	(0018,1088)	From ECG
	Transducer Type	(0018,6031)	LINEAR, CURVED LINEAR or VECTOR_PHASED
	Image Type	(0008,0008)	ORIGINAL\PRIMARY
	Lossy Image Compression	(0028,2110)	Uncompressed – Not Used RLE Compressed – Not Used JPEG Compressed = 1
	Number Of Stages	(0008,2124)	Stress Study Output only
	Number Of Views In Stage	(0008,212A)	Stress Study Output only
	Stage Name	(0008,2120)	Stress Study Output only
	Stage Number	(0008,2122)	Stress Study Output only
	View Name	(0008,2127)	Stress Study Output only
	View Number	(0008,2128)	Stress Study Output only
	Event Elapsed Time	(0008,2130)	Stress Study Output only
	Event Timer Name	(0008,2132)	Stress Study Output only

Table 8 US Image IOD Attributes used

The following table denotes the attributes included in the Ultrasound Multi-Frame Image Object as implemented on the Acuson Cypress. Attributes not listed are not used.

Module	Attribute	Tag	Notes
Patient	Patient Name	(0010,0010)	From New Patient/Study Screen or MWL
	Patient ID	(0010,0020)	From New Patient/Study Screen or MWL
	Patient Birth Date	(0010,0030)	From New Patient/Study Screen or MWL
	Patient Sex	(0010,0040)	From New Patient/Study Screen or MWL
	Other Patient IDs	(0010,1000)	From MWL
	Other Patient Names	(0010,1001)	From MWL
	Patient Age	(0010,1010)	From MWL
	Patient Size	(0010,1020)	From New Patient/Study Screen or MWL
	Patient Weight	(0010,1030)	From New Patient/Study Screen or MWL
	Additional Patient History	(0010,21B0)	From MWL
	Patient Comment	(0010,4000)	Miscellaneous field from New Patient/Study screen
	Admitting Diagnosis Description	(0008,1080)	From Study Indication field on New Patient/Study Screen or MWL
	General Study	Study Instance UID	(0020,000D)
Study Date		(0008,0020)	Date of study creation or from MWL
Study Time		(0008,0030)	Time of study creation
Referring Physician's Name		(0008,0090)	From MWL
Study ID		(0020,0010)	Study Number
Accession Number		(0008,0050)	From New Patient/Study Screen or MWL
Study Description		(0008,1030)	From New Patient/Study Screen or MWL
Study Classification Module	Performing Physician Name	(0008,1050)	From MWL
	Study Comments	(0032,4000)	From Patient Report
General Series	Modality	(0008,0060)	US
	Operator's Name	(0008,1070)	From New Patient/Study Screen or MWL
	Series Instance UID	(0020,000E)	Internally Generated or from MWL
General Equipment	Series Number	(0020,0011)	Always 1
	Manufacturer	(0008,0070)	Set to Acuson
	Institution Name	(0008,0080)	From MWL or New Patient/Study Screen
	Institution Address	(0008, 0081)	From MWL
	Manufacturer's Model Name	(0008,1090)	Set to "Cypress"
	Device Serial Number	(0018,1000)	Set to system serial number
	Station Name	(0008,1010)	Computer Name, if networking option installed
	Software Version	(0018,1020)	Set to 14.0
General Image	Image Date	(0008,0023)	Date of image creation
	Image Time	(0008,0033)	Time of image creation
	Image Number	(0020,0013)	Image number in study (1-n)
	Patient Orientation	(0020,0020)	Always a null string
	Image Comments	(0020,4000)	Either "Entire Study" or "Flagged Loops Only",

			based on transfer type selected on Send Page
Image Pixel	Samples Per Pixel	(0028,0002)	Compression Dependent: Uncompressed = 1 RLE Compressed = 1 JPEG Compressed = 3
	Rows	(0028,0010)	Set to 456 for full screen or TM output, 240 for ROI Size Stress Echo Study Output (non TM)
	Columns	(0028,0011)	Set to 576 for full screen or TM output, 320 for ROI Size Stress Echo Study Output (non TM)
	Bits Allocated	(0028,0100)	Always set to 8
	Bits Stored	(0028,0101)	Always set to 8
	High Bit	(0028,0102)	Always set to 7
	Pixel Data	(7FE0,0010)	
	Planar Configuration	(0028,0006)	Compression Dependent: Uncompressed – Not Used RLE Compressed – Not Used JPEG Compressed = 0
	Photometric Interpretation	(0028,0004)	Compression Dependent: Uncompressed – PALETTE_COLOR RLE Compressed – PALETTE_COLOR JPEG Compressed – YBR_FULL_422
	Pixel Representation	(0028,0103)	0, Pixel representation of unsigned integer
	Red Palette Color Lookup Table Descriptor	(0028,1101)	Used only with Uncompressed or RLE Compressed Image Output
	Green Palette Color Lookup Table Descriptor	(0028,1102)	Used only with Uncompressed or RLE Compressed Image Output
	Blue Palette Color Lookup Table Descriptor	(0028,1103)	Used only with Uncompressed or RLE Compressed Image Output
	Red Palette Color Lookup Table Data	(0028,1201)	Used only with Uncompressed or RLE Compressed Image Output
	Green Palette Color Lookup Table Data	(0028,1202)	Used only with Uncompressed or RLE Compressed Image Output
	Blue Palette Color Lookup Table Data	(0028,1203)	Used only with Uncompressed or RLE Compressed Image Output
Cine Module	Frame Time	(0018,1063)	
Multi-Frame	Number Of Frames	(0028,0008)	
	Frame Increment Pointer	(0028,0009)	Set to (0018, 1063)
SOP Common	Specific Character Set	(0008,0005)	From MWL
	SOP Class UID	(0008,0016)	1.2.840.10008.5.1.4.1.1.3.1
	SOP Instance UID	(0008,0018)	Internally generated
	Specific Character Set	(0008,0005)	
US Region Calibration	Sequence of Ultrasound Regions	(0018,6011)	One for each US region displayed
	>Region Location Min x0	(0018,6018)	
	>Region Location Min y0	(0018,601A)	
	>Region Location Max x1	(0018,601C)	
	>Region Location Max y1	(0018,601E)	
	>Physical Units X Direction	(0018,6024)	
	>Physical Units Y Direction	(0018,6026)	
	>Physical Delta X	(0018,602C)	
	>Physical Delta Y	(0018,602E)	

	>Reference Pixel x0	(0018,6020)	
	>Reference Pixel y0	(0018,6022)	
	>Ref. Pixel Physical Value X	(0018,6028)	
	>Ref Pixel Physical Value Y	(0018,602A)	
	>Region Spatial Format	(0018,6012)	
	>Region Data Type	(0018,6014)	
	>Region Flags	(0018,6016)	
US Image Module	Heart Rate	(0018,1088)	From ECG
	Transducer Type	(0018,6031)	LINEAR, CURVED LINEAR or VECTOR_PHASED
	Image Type	(0008,0008)	ORIGINAL\PRIMARY
	Lossy Image Compression	(0028,2110)	Compression Dependent: Uncompressed – Not Used RLE Compressed – Not Used JPEG Compressed = 1
	Number Of Stages	(0008,2124)	Stress Study Output only
	Number Of Views In Stage	(0008,212A)	Stress Study Output only
	Stage Name	(0008,2120)	Stress Study Output only
	Stage Number	(0008,2122)	Stress Study Output only
	View Name	(0008,2127)	Stress Study Output only
	View Number	(0008,2128)	Stress Study Output only
	Event Elapsed Time	(0008,2130)	Stress Study Output only
	Event Timer Name	(0008,2132)	Stress Study Output only

Table 9 Ultrasound Multi-Frame Image IOD Attributes used

Error Handling

A red icon at the upper right side of the screen will indicate errors occurring during the transfer process. Details about the error will be displayed on the Shutdown page. Prompts for any user intervention will also be displayed on this page.

5.1.2.3 Real-World Activity – Storage Commitment

The user has sent (or archived) a study (images) to another DICOM node. This DICOM node must be configured on the Cypress DICOM Server Setup Page with the “Accepts Storage Commitment” checkbox checked. The Cypress will automatically attempt to send a Storage Commitment request for these images.

Proposed Presentation Context – Send Storage Commitment Request

The Cypress Storage Commitment AE will propose Presentation Contexts as shown in the following table:

Abstract Syntax		Transfer Syntax		Role	Extended Negotiation
Name	UID	Name List	UID List		
Storage	1.2.840.10008.1.20.1	DICOM Implicit VR	1.2.840.10008.1.2	SCU	None

Commitment Push		Little Endian			
Storage Commitment Push	1.2.840.10008.1.20.1	DICOM Explicit VR Little Endian	1.2.840.10008.1.2.1	SCU	None

Table 10 Storage Commitment Request Presentation Context

One Storage Commitment request is sent for all images in the study immediately after the study is sent. This request is contained in the N-ACTION-RQ message. Once this message is sent, the association is kept open while waiting for the N-ACTION-RSP response. Once the N-ACTION-RSP is received, the association is closed. When the Storage Commitment SCP has determined the status of the requested images, it will use the N-EVENT-REPORT to send the commitment status of the images back to the SCU.

Storage Commitment is supported for all the Storage SOP Class UIDs as listed in Table 4.

SOP Specific Conformance to Storage Commitment Service SOP Classes

The Storage Commitment AE provides standard conformance as an SCU for the following standard Storage Service Class SOP:

Service SOP Class Name	SOP Class UID	Conformance Level
Storage Commitment Push	1.2.840.10008.1.20.1	Standard

Table 11 Supported SOP Classes

This is accomplished using the DIMSE N-ACTION Service. The SCU issues a service request with a SOP instance that meets the requirements of the desired ultrasound IOD.

The following table denotes the attributes included in the Storage Commitment Request Object (N-ACTION-RQ) as implemented on the Acuson Cypress. Attributes not listed are not used.

Module	Attribute	Tag	Notes
Storage Commitment Module	Transaction UID	(0008,1195)	Internally Generated
	Reference SOP Sequence	(0008,1199)	Sequence of all images in the study
	>Referenced SOP Class UID	(0008,1150)	SOP Class UID of image n in the study
	>Referenced SOP Instance UID	(0008,1155)	SOP Instance UID of image n in the study

Table 12 Storage Commitment Request Attributes

The following table denotes the attributes included in the Storage Commitment Response (N-EVENT-REPORT) as implemented on the Acuson Cypress. Attributes not listed are not used.

Module	Attribute	Tag	Notes
Storage Commitment Module	Transaction UID	(0008,1195)	Internally Generated
	Reference SOP Sequence	(0008,1199)	Sequence of all images that were successfully stored
	>Referenced SOP Class UID	(0008,1150)	SOP Class UID of image n that was successfully stored
	>Referenced SOP Instance UID	(0008,1155)	SOP Instance UID of image n that was successfully stored
	Failed SOP Sequence	(0008,1998)	Sequence of all images that were not successfully stored
	>Referenced SOP Class UID	(0008,1150)	SOP Instance UID of image m that was not successfully stored
	>Referenced SOP Instance UID	(0008,1155)	SOP Instance UID of image m that was not successfully stored

Table 13 Storage Commitment Response Attributes

5.1.2.4 Real World Activity – Modality Worklist

The Modality Worklist SCU requests that the remote SCP performs a match of all keys specified in the query against the information in its worklist database. The Cypress system provides Standard Conformance to the following DICOM V3.0 SOP Class as an SCU:

Proposed Presentation Context – Send Modality Worklist

The Cypress Modality Worklist AE will propose Presentation Contexts as shown in the following table:

Abstract Syntax		Transfer Syntax		Role	Extended Negotiation
Name	UID	Name List	UID List		
Modality Worklist Information Model - FIND	1.2.840.10008.5.1.4.31	DICOM Implicit VR Little Endian	1.2.840.10008.1.2	SCU	None
Modality Worklist Information Model - FIND	1.2.840.10008.5.1.4.31	DICOM Explicit VR Little Endian	1.2.840.10008.1.2.1	SCU	None

Table 14 Modality Worklist Presentation Context

SOP Specific Conformance to Modality Worklist Service SOP Classes

The Modality Worklist AE provides standard conformance as an SCU for the following standard Storage Service Class SOP:

Service SOP Class Name	SOP Class UID	Conformance Level
Modality Worklist Information Model - FIND	1.2.840.10008.5.1.4.31	Standard

Table 15 Supported SOP Classes

The following table provides the list of attributes requested in the Modality Worklist Query.

Attribute Name	Tag
Patient Name (Last, First)	(0010,0010)*
Patient ID	(0010,0020)*
Accession Number	(0008,0050)*
Requested Procedure ID	(0040,1001)*
Scheduled Station AE Title	(0040,0001)*
Study Start Date	(0040,0002)*
Modality	(0008,0060)*
Referring Physician's Name	(0008,0090)
Study Description	(0008,1030)
Admitting Diagnosis	(0008,1080)
Patient Birthdate	(0010,0030)
Patient Sex	(0010,0040)
Patient Age	(0010,1010)
Patient Size (Height)	(0010,1020)
Patient Weight	(0010,1030)
Patient Address	(0010,1040)
Military Rank	(0010,1080)
Medical Alert	(0010,2000)
Contrast Allergies	(0010,2110)
Ethnic Group	(0010,2160)
Smoking Status	(0010,21A0)
Additional Patient History	(0010,21B0)
Pregnancy Status	(0010,21C0)
Last Menstrual Date	(0010,21D0)
Study Instance UID	(0020,000D)
Series Instance UID	(0020,000E)
Requesting Physician	(0032,1032)
Requesting Service	(0032,1033)
Requested Procedure Description	(0032,1060)
Requested Procedure Code Sequence	(0032,1064)
>Code Value	(0008,0100)
>Coding Scheme Designator	(0008,0102)
>Coding Scheme Version	(0008,0103)
>Code Meaning	(0008,0104)
Requested Contrast Agent	(0032,1070)
Admission ID	(0038,0010)
Issuer of Admission ID	(0038,0011)
Special Needs	(0038,0050)
Current Patient Location	(0038,0300)
Patient State	(0038,0500)
Scheduled Procedure Sequence	(0040,0100)

>Modality Element	(0008,0060)
>Scheduled Station AET	(0040,0001)
>Scheduled Procedure Start Date	(0040,0002)
>Schedule Procedure Start Time	(0040,0003)
>Scheduled Procedure End Date	(0040,0004)
>Scheduled Procedure End Time	(0040,0005)
>Scheduled Physician Name	(0040,0006)
>Scheduled Procedure Description	(0040,0007)
>Scheduled Action Item Code Sequence	(0040,0008)
>>Code Value	(0008,0100)
>>Coding Scheme Designator	(0008,0102)
>>Coding Scheme Version	(0008,0103)
>>Code Meaning	(0008,0104)
>Scheduled Procedure Step ID	(0040,0009)
>Scheduled Station Name	(0040,0010)
>Scheduled Procedure Step Location	(0040,0011)
>Pre Medication	(0040,0012)
>Scheduled Procedure Step Status	(0040,0020)
>Scheduled Procedure Step Comments	(0040,0400)
Reason For Requested Procedure	(0040,1002)
Requested Procedure Priority	(0040,1003)
Patient Transport Arrangements	(0040,1004)
Confidentiality Code	(0040,1008)
Reporting Priority	(0040,1009)
Names of Intended Recipients	(0040,1010)
Requested Procedure Comments	(0040,1400)
Reason For Imaging Service	(0040,2001)
Issue Date of Imaging Request	(0040,2004)
Issue Time of Imaging Request	(0040,2005)
Order Entered By	(0040,2008)
Order Enterer Location	(0040,2009)
Order Callback Phone Number	(0040,2010)
Placer Order Number / Imaging Service Request	(0040,2016)
Filler Order Number / Imaging Service Request	(0040,2017)
Imaging Service Request Comments	(0040,2400)

* indicates attribute may be populated for query

Table 16 Modality Worklist Query Attributes

6.0 Removable Interchange Media Specifications

This implementation supports 90mm (3.5 inch) DICOM MOD removable media. It conforms to DICOM 3.0 Parts 10, 11, and 12.

Limitations:

- Studies from the Cypress system and other DICOM FSCs cannot be mixed on a single MO disk. A warning will be displayed if a save is initiated to an MO disk containing a non-Cypress system file set. The save will not occur.

- Saved DICOM studies cannot be opened for review on the Cypress system.
- Saved Cypress system DICOM studies cannot be opened for review from MOD on other Acuson or Siemens ultrasound systems.

6.1 Supported SOP Classes

The Cypress system supports standard conformance to the following DICOM SOP classes:

Abstract Syntax		Role
Name	UID	
Ultrasound Image Storage	1.2.840.10008.5.1.4.1.1.6.1	FSC
Ultrasound Multi-Frame Image Storage	1.2.840.10008.5.1.4.1.1.3.1	FSC
Directory Storage	1.2.840.10008.1.3.10	FSC, FSU

Table 17 Media Storage SOP Classes

6.2 Proposed Interchange Media Transfer Syntaxes

The Transfer Syntax used with the Ultrasound Image Storage and Multi-Frame Image Storage SOP classes will correspond to the selected compression type, with Explicit VR Little Endian encoding. The Directory Storage SOP class will always use Explicit VR Little Endian encoding.

Abstract Syntax		Selected Compression	Transfer Syntax	
Name	UID		Name	UID List
Ultrasound Image Storage	1.2.840.10008.5.1.4.1.1.6.1	None	Explicit VR, Little Endian	1.2.840.10008.1.2.1
Ultrasound Image Storage	1.2.840.10008.5.1.4.1.1.6.1	RLE	Explicit VR, Run Length Encoding	1.2.840.10008.1.2.5
Ultrasound Image Storage	1.2.840.10008.5.1.4.1.1.6.1	JPEG	Explicit VR, JPEG baseline	1.2.840.10008.1.2.4.50
Ultrasound Multi-Frame Image Storage	1.2.840.10008.5.1.4.1.1.3.1	None	Explicit VR, Little Endian	1.2.840.10008.1.2.1
Ultrasound Multi-Frame Image Storage	1.2.840.10008.5.1.4.1.1.3.1	RLE	Explicit VR, Run Length Encoding	1.2.840.10008.1.2.5
Ultrasound Multi-Frame Image Storage	1.2.840.10008.5.1.4.1.1.3.1	JPEG	Explicit VR, JPEG baseline	1.2.840.10008.1.2.4.50
Directory Storage	1.2.840.10008.1.3.10	any	Explicit VR, Little Endian	1.2.840.10008.1.2.1

Table 18 Proposed Transfer Syntaxes for Interchange Media

6.3 Physical Storage Media and Format

The physical storage media is 90mm (3.5 inch) Magneto Optical disks in capacities from 128MB to 640MB. When formatted on the Cypress system, the disks are in FAT format, with one partition. A partition table is present, due to operating system requirements.

7.0 Communication Profiles

All Acuson Cypress system application entities utilize the DICOM 3.0 TCP/IP communication support as defined in PS3.8 (Part 8) of the DICOM 3.0 Standard.

7.1 TCP/IP Stack Supported

Each process inherits its TCP/IP stack from the Acuson Cypress' operating system's TCP/IP stack. Port number 104 is used as the default for DICOM communication with the Acuson Cypress.

7.1.1 Physical Media Supported

Standard representations of IEEE 802.3 10BaseT/100BaseT ("twisted pair") are supported

7.1.2 Chapter Extensions/Specializations/Privatizations

No private elements are used by the Acuson Cypress AE.

8.0 Configuration

Acuson Cypress Networking and DICOM parameters can be configured through the Acuson Cypress Setup menu screens. The following DICOM-related setup screens are supported:

- Network Identification
- Cypress DICOM Information
- DICOM Server Information
- Modality Worklist Server Information

The Cypress supports Port Numbers up to 65535 on all configuration pages.

8.1 Network Identification

The Network Identification Setup Screen allows the user to configure the local Network Parameters. The following parameters are configurable for the Acuson Cypress system:

- Network Setup Name (Alias)
- Computer Name
- Workgroup Name
- IP Address
- Subnet Mask

- Default Gateway
- Use DHCP checkbox

8.2 Cypress DICOM Information

The Cypress DICOM Information setup screen allows the user to configure the Cypress DICOM Application Entity. The following parameters are configurable for the Acuson Cypress system:

- Cypress AE Title
- Cypress AE Port Number
- PDU Length
- Network Timeout 1 (Data Inter Block Timeout)
- Network Timeout 2 (Timeout between DICOM upper layer service primitives)

8.3 DICOM Server Information

The Cypress DICOM Server setup screen allows the user to configure up to 32 DICOM Servers (C-Store SCPs). The following parameters are configurable for the Acuson Cypress system:

- DICOM Server Alias
- DICOM Server AE Title
- DICOM Server IP Address
- DICOM Server Port Number
- Ignore Server C-Store Response Checkbox (if checked, an error message not displayed when a non zero C-Store Response status is received)
- Storage Commitment Checkbox (if checked, Storage Commitment is sent to this DICOM Server when the C-STORE operation is complete)

Buttons to perform Ping and DICOM Verify (C-Echo) tests are provided on the setup page

8.4 Modality Worklist Server Information

The Cypress Modality Worklist Server Setup screen allows the user to configure up to 4 Modality Worklist Servers. The following parameters are configurable for the Acuson Cypress system:

- Modality Worklist Server Alias
- Modality Worklist Server AE Title
- Modality Worklist Server IP Address

- Modality Worklist Server Port Number

Buttons to perform Ping and DICOM Verify (C-Echo) tests are provided on the setup page.

The desired Worklist Server and the maximum number of returns per query are configurable from the Modality Worklist Query page.

8.5 Support of Extended Character Sets

The “ISO-IR 100” Latin Alphabet 1 Extended character set is supported by the Acuson Cypress system.