

# SIEMENS

## ***ACUSON Antares™ Ultrasound System***



### **DICOM Conformance Statement**

**for RM165 Motherboard Systems**

Version 5.0 18-Aug-2010

© Siemens Healthcare 2007-2010  
All rights reserved

Siemens Healthcare,  
Henkestr. 127, D-91052 Erlangen, Germany

Headquarters: Berlin and Munich  
Siemens AG, Wittelsbacher Platz 2, D-80333 Munich, Germany

ACUSON Antares™ is a trademark of Siemens Healthcare.

**Table of Contents**

1.0	Purpose .....	7
1.1	Scope .....	7
2.0	References .....	7
3.0	Definitions .....	8
3.1	Support of Extended Character Sets .....	8
4.0	Implementation Model .....	9
4.1	Application Data Flow Diagrams .....	9
4.1.1	Verification .....	9
4.1.2	Storage .....	10
4.1.3	Structured Reporting .....	10
4.1.4	Storage Commitment .....	10
4.1.5	Print .....	11
4.1.6	Modality Worklist .....	11
4.1.7	Modality Performed Procedure Step .....	11
4.2	AE Functional Definitions .....	14
4.2.1	Verification Real-World Activities .....	14
4.2.2	Storage Real-World Activities .....	14
4.2.3	Structured Reporting Real-World Activities .....	14
4.2.4	Storage Commitment Real-World Activities .....	14
4.2.5	Print Real-World Activities .....	14
4.2.6	Worklist Real-World Activities .....	15
4.2.7	Modality Performed Procedure Step Real-World Activity .....	16
4.2.8	Sequencing of Real-World Activities .....	16
5.0	AE Specifications .....	17
5.1	Verification AE Specification .....	17
5.1.1	Association Initiation by Real-World Activity .....	17
5.2	Storage AE Specification .....	18
5.2.1	Association Establishment Policies .....	18
5.2.2	Association Initiation by Real-World Activity .....	19
5.3	Storage Commitment AE Specification .....	47
5.3.1	Association Establishment Policies .....	47
5.3.2	Association Initiation by Real-World Activity .....	47
5.3.3	Association Acceptance Policy .....	48
5.4	Print AE Specification .....	50
5.4.1	Association Establishment Policies .....	50
5.4.2	Association Initiation by Real-World Activity .....	51
5.5	Modality Worklist AE Specification .....	58
5.5.1	Association Establishment Policies .....	59
5.5.2	Association Initiation by Real-World Activity .....	59
5.6	Modality Performed Procedure Step AE Specification .....	64
5.6.1	Association Establishment Policies .....	64
5.6.2	Association Initiation by Real-World Activity .....	64
6.0	Communication Profiles .....	70
6.1	TCP/IP Stack Supported .....	70
6.1.1	Physical Media Supported .....	70
7.0	Extensions/Specializations/Privatizations .....	70
7.1	Standard extended/specialized/private Syntaxes .....	70
7.2	Private Transfer Syntaxes .....	70
8.0	Configuration .....	70
8.1	Basic System Configuration .....	70
8.2	DICOM Network Configuration .....	71
8.2.1	Local Host - TCP/IP and General .....	71
8.3	DICOM Storage Configuration .....	71
8.4	DICOM HIS/RIS Configuration .....	71

8.5	DICOM Print Configuration .....	72
8.6	“Print/Store” Key Configuration .....	72
8.6.1	Multiple Destinations - Auto Transfer .....	72
8.6.2	Overlay or Burned in graphics .....	72
8.6.3	Secondary Capture Image Storage SOP Class .....	72
8.6.4	Auto Retry .....	73
8.6.5	Compression .....	73
8.6.6	Print Routing - Auto Transfer .....	73
9.0	Media Storage .....	74
9.1	Implementation Model .....	74
9.2	Application Data Flow Diagram .....	74
10.0	Media Storage AE Functional Definition .....	74
10.1	Real-World Activities for Media Storage .....	75
10.1.1	Browse Directory Information—Real World Activity .....	75
10.1.2	Import into Local Storage—Real-World Activity .....	75
10.1.3	Export to Local Archive Media—Real-World Activity .....	75
10.1.4	Sequencing of Real World Activities .....	75
10.2	AE Specifications .....	75
10.2.1	Antares Media Storage AE Specification .....	75
10.2.2	File Meta Information Options .....	75
10.3	Media Storage Application Profile .....	76
10.3.1	DICOMDIR keys .....	76
10.3.2	Compliance to STD-GEN-CDR .....	78
10.3.3	Compliance to STD-US-SC-MF-CDR .....	78
10.3.4	Compliance to STD-US-ID-MF-CDR .....	79
10.4	Augmented and Private Profiles .....	79
10.4.1	Augmented Application Profiles .....	79
10.4.2	Private Application Profiles .....	80
10.5	Extensions, Specializations and Privatizations of SOP Classes and Transfer Syntaxes .....	80
10.6	Configuration .....	80
10.6.1	AE Title Mapping .....	80
10.7	Support of Extended Character Sets .....	80
11.0	Appendix A: OB-GYN Structured Report Measurements .....	81
11.1	Patient Characteristics .....	81
11.2	OB-GYN Summary .....	82
11.3	Fetus Summary .....	82
11.3.1	US Age Authors .....	83
11.3.2	EFW Authors .....	83
11.3.3	EFW% Authors .....	84
11.3.4	EFW Gestational Age Authors .....	84
11.4	Fetal Biometry Ratios .....	84
11.5	Fetal Biometry Measurements .....	85
11.5.1	AC Gestational Age Authors .....	88
11.5.2	AC Growth Authors .....	88
11.5.3	BPD Gestational Age Authors .....	88
11.5.4	BPD Growth Authors .....	89
11.5.5	FL Gestational Age Authors .....	89
11.5.6	FL Growth Authors .....	90
11.5.7	HC Gestational Age Authors .....	90
11.5.8	HC Growth Authors .....	90
11.6	Fetal Long Bones Biometry Measurements .....	91
11.6.1	HL Gestational Age Authors .....	92
11.6.2	HL Growth Authors .....	92
11.7	Fetal Cranium .....	92
11.7.1	Binoc D Gestational Age Authors .....	93
11.8	Amniotic Sac .....	93

11.9	Early Gestation Biometry Measurements .....	93
11.9.1	CRL Gestational Age Authors .....	94
11.9.2	CRL Growth Authors .....	94
11.9.3	GSD Gestational Age Authors .....	94
11.9.4	GSD Growth Authors .....	94
11.10	Fetal Biophysical Profile .....	95
11.11	Pelvis and Uterus.....	95
11.12	Fetal and Pelvic Vasculature .....	95
11.12.1	Fetal Vasculature .....	97
11.12.2	Pelvic Vasculature.....	97
11.13	Private Section: Ovaries .....	97
11.14	Private Sections: Left Follicles and Right Follicles .....	98
11.15	Private Sections: Left Cysts and Right Cysts .....	99
11.16	Private Section: Bladder .....	99
11.17	Private Section: Maternal Kidney.....	100
12.0	Appendix B: Vascular Structured Report Measurements .....	102
12.1	Patient Characteristics .....	103
12.2	Procedure Summary .....	104
12.3	Blood Vessels of Head (Left Intracranial Cerebral Vessels) .....	104
12.4	Blood Vessel of Head (Right Intracranial Cerebral Vessels).....	104
12.5	Blood Vessel of Head (Unilateral Intracranial Cerebral Vessels) .....	105
12.6	Artery of Neck (Left Extracranial Arteries, Carotid Ratios) .....	105
12.7	Artery of Neck (Right Extracranial Arteries, Carotid Ratios).....	106
12.8	Artery of Lower Extremity (Left Side).....	107
12.9	Artery of Lower Extremity (Right Side) .....	109
12.10	Artery of Upper Extremity (Left Side).....	111
12.11	Artery of Upper Extremity (Right Side) .....	112
12.12	Vascular Structure of Kidney (Left Side) .....	113
12.13	Vascular Structure of Kidney (Right Side).....	113
12.14	Artery of Abdomen (Unilateral) .....	114
12.15	Vein of Abdomen (Left Side).....	115
12.16	Vein of Abdomen (Right Side) .....	115
12.17	Vein of Abdomen (Unilateral).....	115
12.18	Ultrasound Graft.....	116
12.19	Private Section: Mixed Carotid Ratios .....	118
12.20	Private Section: Kidney.....	118
12.21	Private Section: Ureter.....	118
12.22	Private Section: Bladder .....	119
12.23	Private Section: Liver, Gall Bladder, Pancreas.....	119
12.24	Private Section: Spleen .....	120
13.0	Appendix C: Echocardiography Structured Report .....	121
13.1	Left Ventricle .....	121
13.2	Right Ventricle.....	129
13.3	Left Atrium.....	130
13.4	Right Atrium .....	131
13.5	Aortic Valve.....	131
13.6	Mitral Valve .....	132
13.7	Pulmonic Valve .....	135
13.8	Tricuspid Valve .....	136
13.9	Aorta .....	137
13.10	Pulmonary Artery .....	137
13.11	Pulmonary Venous Structure.....	137

**List of Tables**

Table 1: References.....	7
Table 2: Acronyms and Abbreviations .....	8
Table 3: Patient Registration fields populated from Worklist .....	15
Table 4: Supported SOP Classes .....	17
Table 5: Verification Presentation Context Table.....	18
Table 6: Supported Storage SOP Classes .....	18
Table 7: Store Presentation Context Table.....	20
Table 8: Photometric Interpretation.....	21
Table 9: US Image IOD Attributes .....	21
Table 10: Secondary Capture IOD Attributes .....	28
Table 11: US-MF IOD Attributes – Clips .....	31
Table 12: US-MF Image IOD Attributes - 3D Volumetric Data .....	35
Table 13: Comprehensive SR Image IOD Modules.....	44
Table 14: SR Document Series Module.....	45
Table 15: SR Document General Module .....	45
Table 16: SR Document Content Module Attributes.....	46
Table 17: Root Templates for SR SOP Instances .....	46
Table 18: C-STORE Status Responses.....	47
Table 19: Standard SOP Classes as Storage Commitment Push Model.....	47
Table 20: Initiation Presentation Context Storage Commitment Request .....	48
Table 21: Presentation Context accepted for Storage Commitment .....	49
Table 22: Basic Gray Scale Print Management Meta SOP Classes .....	50
Table 23: Basic Color Print Management Meta SOP Classes.....	50
Table 24: Presentation Context Table .....	52
Table 25: Basic Film Session N_CREATE_RQ attributes .....	53
Table 26: Attributes of the N_DELETE_RQ - Basic Film Session SOP Class .....	53
Table 27: Basic Film Session SOP Status.....	53
Table 28: Supported DIMSE Services for Basic Film Box SOP Class .....	54
Table 29: Used Basic Film Box N_CREATE_RQ Attributes.....	54
Table 30: Attributes of the N_DELETE_RQ on the Basic Film Session SOP Class .....	55
Table 31: Basic Film Box SOP Status .....	55
Table 32: Used Basic Grayscale Image Box N-Set Attributes.....	56
Table 33: Basic Grayscale Image Box SOP Status .....	56
Table 34: Used Basic Color Image Box N-Set Attributes .....	56
Table 35: Basic Color Image Box SOP Status.....	57
Table 36: Used Printer N-Event Reports .....	57
Table 37: Mandatory Printer N_GET_RSP, N_EVENT_REPORT_RQ Attributes .....	58
Table 38: Used Print Job N-Event Reports.....	58
Table 39: SOP Classes as an SCU .....	59
Table 40: Worklist Presentation Context Table.....	59
Table 41: Modality Worklist Matching Key Attributes (Broad Query).....	60
Table 42: Modality Worklist Matching Key Attributes (Patient Based Query).....	60
Table 43: Modality Worklist C_FIND_RSP Return Key Attributes .....	61
Table 44: C-FIND Status Responses.....	63
Table 45: SOP Classes as an SCU .....	64
Table 46: Proposed Presentation Contexts .....	65
Table 47: Performed Procedure Step N-CREATE Attributes .....	65
Table 48: N-CREATE Response Status .....	68
Table 49: Performed Procedure Step N-SET Attributes .....	68
Table 50: N-SET Response Status.....	69
Table 51: User Configurable Printer Parameters.....	72
Table 52: Application profiles, Activities, and Roles for DICOM Exchange Media.....	75
Table 53: DICOMDIR Keys.....	76

Table 54: STD-GEN-CDR Supported SOP Classes.....	78
Table 55: STD-US-SC-MF-CDR Supported SOP Classes.....	78
Table 56: STD-US-ID-MF-CDR Supported SOP Classes .....	79
Table 57: Augmented Application profiles, Activities, and Roles for DICOM Exchange Media .....	79
Table 58: AUG-GEN-CDR, AUG-US-SC-MF-CDR and AUG-US-ID-MF-CDR Supported SOP Classes..	80

## 1.0 Purpose

This document describes the conformance to the ACR-NEMA DICOM 3.0 Standard by the ACUSON Antares ultrasound system software version 5.0 from Siemens Medical Solutions, Inc. Ultrasound Division. It shall establish the conformance specifications for this system only, and does not apply to other products offered by Siemens Medical Solutions, or its affiliates.

The ACUSON Antares system is a device that generates ultrasound images that can be sent using DICOM standard protocols and definitions to other DICOM compliant devices that support the SOP classes defined in Table 4: on Page 17.

### 1.1 Scope

The DICOM standard provides a well-defined set of structures and protocols that allow interoperability of a wide variety of medical imaging devices. The ACUSON Antares system provides support for essential services related to ultrasound scanning and connectivity to DICOM compliant devices. ACUSON Antares system products will not support all features supported by the DICOM standard. This document clearly states the DICOM services and data classes that are supported by the applications included with the ACUSON Antares. The intent of this document is to allow users and other vendors who also conform to the DICOM standard to exchange information within the specific context of those elements of the DICOM standard that ACUSON Antares system supports.

This document is written with respect to the adopted portions of the DICOM standard, Version 3. The following sections of this document follow the outline specified in the DICOM Standard NEMA publication PS3.3 [1].

## 2.0 References

Specifications of the DICOM 3.0 standard may be obtained from ACR-NEMA for customers who require detailed information.

**Table 1: References**

Document Title	Location
[1] Part 2 of the DICOM Standard: NEMA Standards Publication PS 3.2-2004, Digital Imaging and Communications in Medicine (DICOM), Part 2: Conformance	<a href="http://medical.nema.org/dicom/2004.html">http://medical.nema.org/dicom/2004.html</a>
[2] Part 4 of the DICOM Standard: NEMA Standards Publication PS 3.4-2004, Digital Imaging and Communications in Medicine (DICOM), Part 4: Service Class Specifications	<a href="http://medical.nema.org/dicom/2004.html">http://medical.nema.org/dicom/2004.html</a>
[3] Part 16 of the DICOM Standard, NEMA Standards Publication PS 3.16-2004, Digital Imaging and Communication in Medicine (DICOM), Part 16: Content Mapping Resource	<a href="http://medical.nema.org/dicom/2004.html">http://medical.nema.org/dicom/2004.html</a>

### 3.0 Definitions

**Table 2: Acronyms and Abbreviations**

Acronym or Abbreviation	Definition
ACR-NEMA	American College of Radiology - National Electrical Manufacturer's Association
AE	Application Entity
Conformance Statement	A formal statement associated with a specific implementation of the DICOM Standard. It specifies the Service Classes, Information Objects, Communications Protocols and Media Storage Application Profiles supported by the implementation.
DICOM 3.0	Digital Imaging and Communications in Medicine, Version 3.0.
DIMSE	DICOM Message Service Element
EBE	Explicit Big Endian transfer syntax
ELE	Explicit Little Endian transfer syntax
ILE	Implicit Little Endian transfer syntax
C-STORE	Composite Store
Ethernet	Network topology devised in 1976 by DIX (DEC/Intel/Xerox) which is the most common in practice today.
IOD	Information Object Definition
MWL	Modality Worklist
OB	Obstetric or Obstetrical
OOG	Object Oriented Graphics
PACS	Picture Archiving and Communications Systems
PDU	Protocol Data Unit
RWA	Real-World Activity
SCP	Service Class Provider
SCU	Service Class User
SOP	Service-Object Pair
SR	Structured Reporting
syngo	Siemens DICOM Application Framework - Common User SW
UID	Unique identifier

#### 3.1 Support of Extended Character Sets

The Antares platform supports the ISO 8859 Latin 1 (ISO-IR 100) character set family and the same family with code extensions (ISO 2022 IR 100 Latin-1).

## 4.0 Implementation Model

ACUSON Antares system users can store images directly on the system hard drive. Images can also be transferred to DICOM workstations and archive servers on a network. Storage Commitment can be used to insure that patient images and data is safely committed. The system is capable of querying a HIS/RIS, using DICOM Basic Worklist, for a list of scheduled patient procedures. Measurements from OB, Vascular, and Cardiac exams can be exported as DICOM SR Objects. Performed procedure status and other procedure information can be returned to the HIS/ RIS using Modality Performed Procedure Step (MPPS).

ACUSON Antares system real world activities are indicated by “Real World Activity” name while “Antares AE” indicates the invoked Application Entity. Similarly, the activities associated with service providers are indicated as “Real World Service Activity.”

### 4.1 Application Data Flow Diagrams

Figure 8: on page 13 illustrates the ACUSON Antares system Application Entities (AE) in the context of the implementation model. Relationships between users invoked activities (in the circles at the left of the AEs) and the associated real-world activities provided by DICOM service providers (in the circles on the right side of the diagram) are shown.

#### 4.1.1 Verification

Verification is available in the DICOM Network nodes, Print Devices and HIS/RIS Nodes configuration pages of the Local Service UI. Verification can be used for diagnostic purposes. When used as a diagnostic tool, Verification will return the following messages to the user:

- Application Entity Title “AE Name” is responding.
- Application Entity Title “AE Name” is not responding.

The Antares also supports the Verification service as SCP, and responds to Verification requests from remote applications

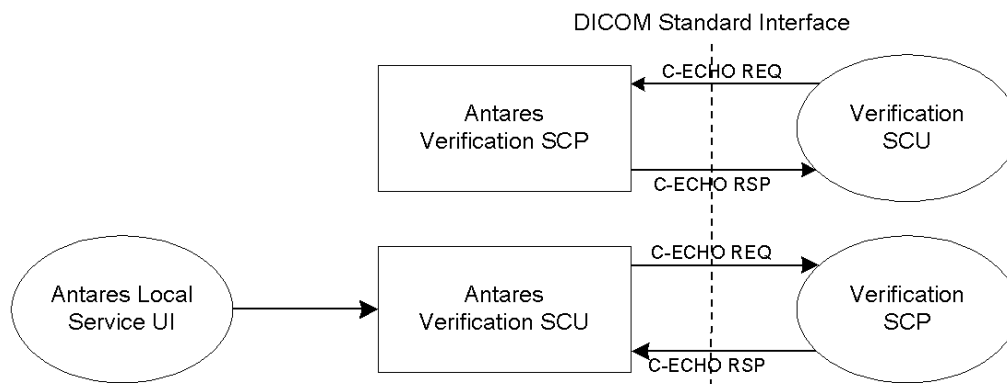
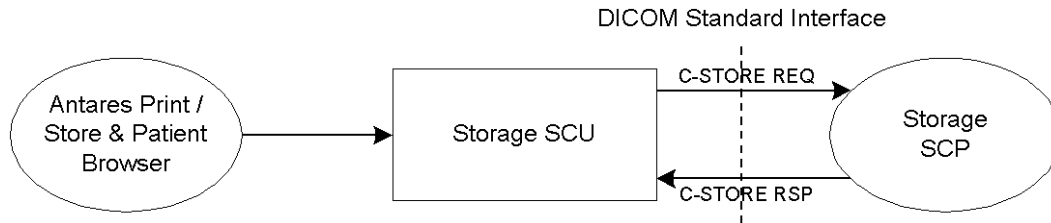

Figure 1: Verification Model

**4.1.2 Storage**

The Antares Storage Application Entity originates associations for transfer of DICOM Composite Information Objects to remote Application Entities. The Antares system acts as SCU for the C-STORE DICOM network service.

If configured, DICOM Store may be invoked by pressing a “Print/Store” key, which causes the image currently displayed on the system monitor screen to be captured to hard drive and transferred. Print/Store keys are configurable through the system presets function. Images may also be manually transferred through the Patient Browser UI screen.



**Figure 2: Store Model**

**4.1.3 Structured Reporting**

The Structured Reporting Storage Service Class defines an application-level class of service which facilitates the transfer of measurements obtained from OB, Vascular, and Cardiac studies to storage devices that support the DICOM Comprehensive Structured Reporting Storage Service class.

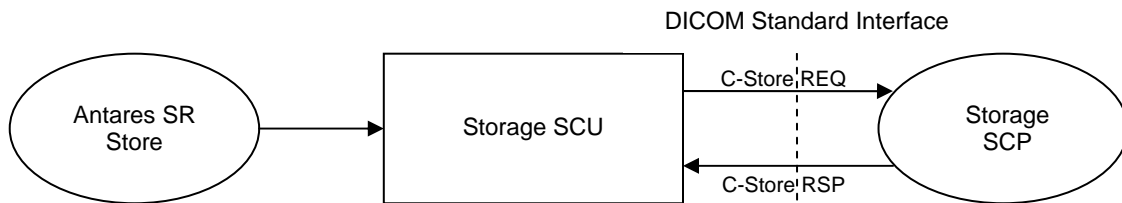

**Figure 3: Structured Report Model**

**4.1.4 Storage Commitment**

The Storage Commitment service class defines an application-level class of service which facilitates the commitment to storage. It performs an additional task of commitment of composite objects apart from the network based storage of images as defined by the Storage Service class.

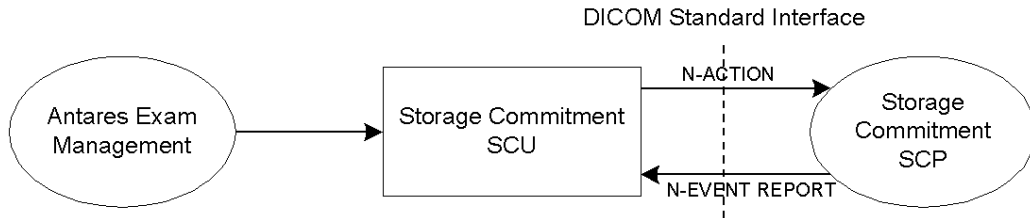

Figure 4: Storage Commitment Model

4.1.5 Print

The Print Management Service Classes define an application-level class of services which facilitate the printing of images on a hardcopy medium. The print management SCU and print management SCP are peer DICOM print management application entities. The DICOM print application supports the print management DIMSE services as SCU.

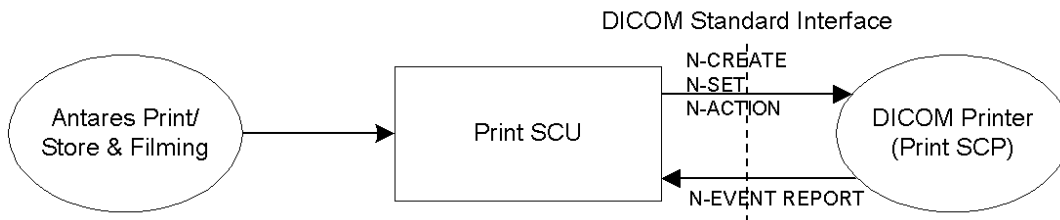

Figure 5: Print Model

4.1.6 Modality Worklist

The Modality Worklist service class defines an application-level class of service which facilitates the transfer of worklists from the information system to the imaging modality. The worklist is queried by the AE and supplies the SCU with the scheduled tasks which have to be performed on the modality. The Antares DICOM worklist application supports the worklist service as SCU.

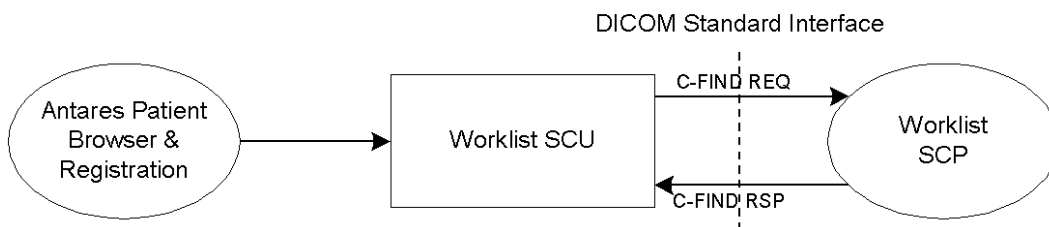

Figure 6: Modality Worklist Model

**Note:** It is configurable to get the worklist updates either automatically (in a configurable time interval) or manually (initiated by the user). The user can do a broad worklist query (all jobs for the own modality or own application entity).

4.1.7 Modality Performed Procedure Step

The Modality Performed Procedure Step service class defines an application-level class of service which facilitates the transfer of procedure status and billing information from the imaging modality to the information system. The performed procedure step is sent by the

Antares AE and supplies the SCP with the performed tasks on the modality. The DICOM performed procedure step application supports the performed procedure step service as SCU.

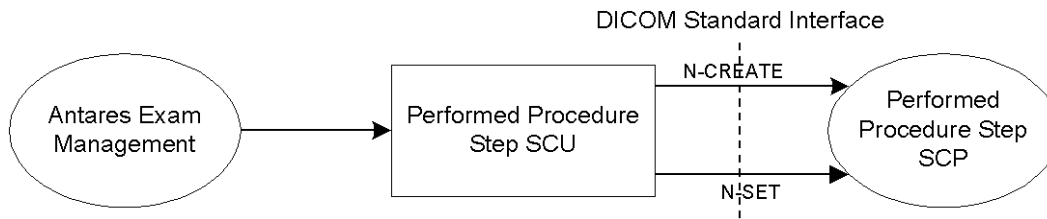

**Figure 7: Modality Performed Procedure Step Model**

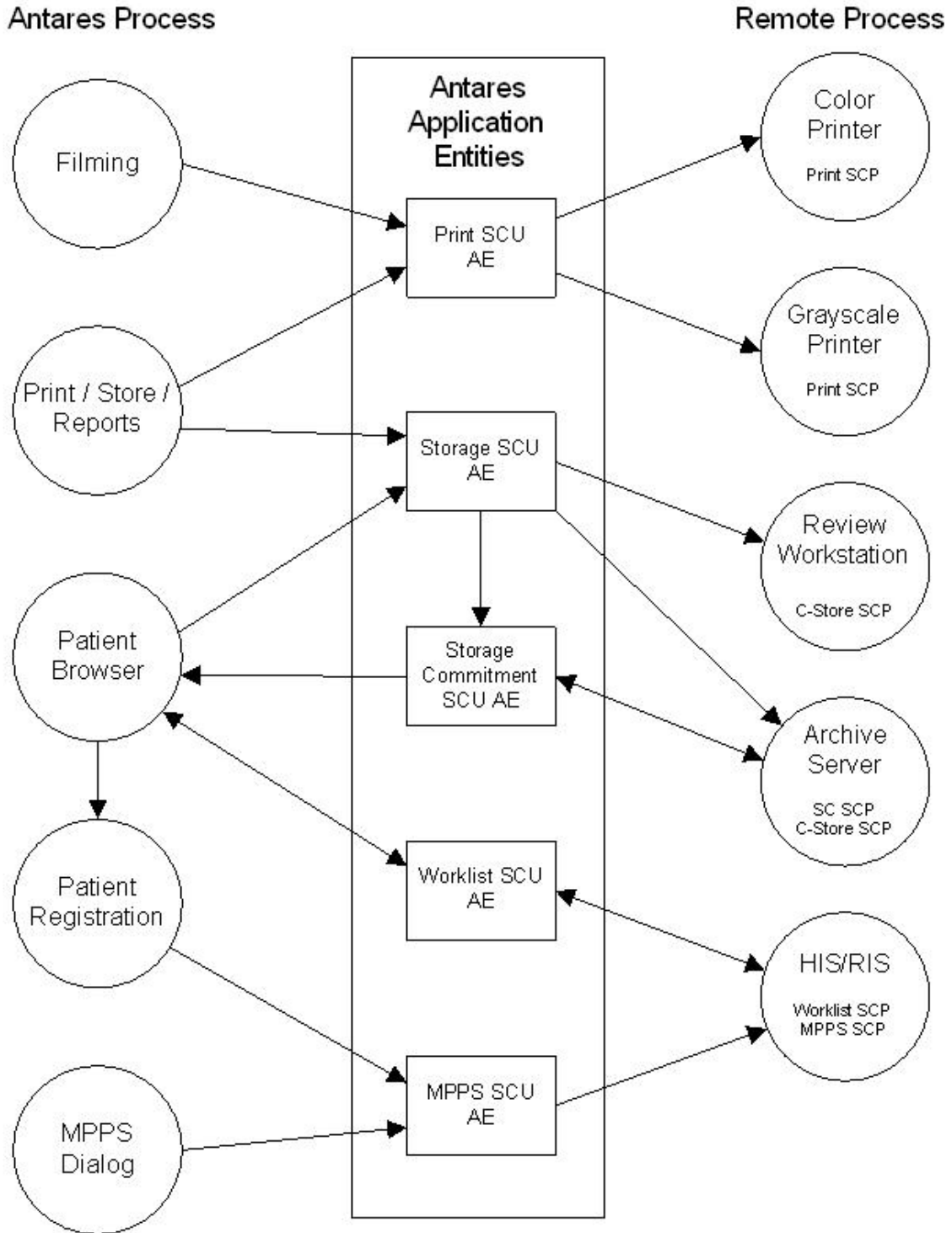

Figure 8: Implementation Model

## **4.2 AE Functional Definitions**

### **4.2.1 Verification Real-World Activities**

The Antares verification application entity support the verification service class as a SCU and as a SCP. As the SCU it allows the operator to verify the ability of a remote DICOM node to receive DICOM messages. As a SCP it allows for remote DICOM nodes to verify that DICOM message exchange is possible with the Antares system.

### **4.2.2 Storage Real-World Activities**

The Antares Storage application entity performs all of the functions necessary to transmit ultrasound images and associated data to DICOM network archive servers and/or workstations. The Antares Storage AE supports the Ultrasound Image Storage SOP Class, the Ultrasound Multi-Frame Image Storage SOP Class and the Secondary Capture Image SOP Class as a SCU. The Antares Storage AE initiates separate associations to the storage SCP servers, each time the user selects “Store/Print” or “Send/Archive To Destination”.

### **4.2.3 Structured Reporting Real-World Activities**

The Antares Storage application entity performs all of the functions necessary to transmit associated data to DICOM network archive servers and/or workstations. The Antares Storage AE supports the Ultrasound Comprehensive SOP class as SCU. The Antares Storage AE initiates separate associations to the storage SCP servers, when the study is closed and “Image Auto Transfer” in “Store/Print” is enabled or each time the user selects “Send/Archive To Destination”.

### **4.2.4 Storage Commitment Real-World Activities**

The Storage Commitment Push Model SCU (SC-SCU) uses the Storage Commitment Service Class to request commitment for one or more composite objects from the Storage Commitment Push Model SCP (SC-SCP). SC-SCU issues an N\_ACTION-RQ to SC-SCP containing a list of references to composite objects, requesting that the SC-SCP takes responsibility for storage commitment of the composite objects. If the SC-SCP has determined that all the composite objects exist and it has successfully completed storage commitment for the set of composite objects, it issues an N\_EVENT-REPORT-RQ with status successful and the list of stored images. SC-SCU now knows that the composite objects have been committed by SC-SCP and can delete its copies of composite objects. The information from the N\_EVENT-REPORT-RQ is propagated back to the user interface.

The Antares SCU can be configured to receive the N\_EVENT\_REPORT-RQ on the same association on which N\_ACTION-RQ was sent or on a different association.

### **4.2.5 Print Real-World Activities**

The Antares Print AE provides all aspects of the Print Management SCU. The AE initiates separate associations to the print servers, verifying their on-line status when the user selects “Print/Store” or “Expose Film Job.” The Antares Print AE accommodates both grayscale and color print servers.

To invoke the Print “REAL WORLD ACTIVITY” the user selects a “Print/Store” key. Film sheets can be transferred immediately after being filled, at the end of exam, or queued to hard disk for transfer later.

After an imaging exam is complete, the user has the ability to Print images stored on the hard drive using the Filming UI. Invoking the “Expose Film Job” Real World activity invokes the DICOM Print activity for selected exams or individual images. “Expose Film Job” is available through the Filming UI function.

**4.2.6 Worklist Real-World Activities**

Patient registration can be automated by using the ‘Worklist’ Real World Activity.

Double clicking the ‘Scheduler’ icon in the patient browser UI initiates a manual Worklist query. If no matches are found, a message will be presented to the operator indicating so. If one or more patients are found, the scheduler list will be updated with the scheduled procedures. The Worklist feature can be configured to query for either the procedures scheduled for the Local Site (Antares Worklist SCU AE Title) or for Ultrasound scheduled procedures (Modality = US). Queries can be made for today’s scheduled procedures, or a user specified range of scheduled procedure dates and times. The system can also be configured to perform automatic Worklist queries at user specified intervals.

Patient based queries are supported in the Antares 5.0 release.

Selection of a patient from the list will cause all demographic information for that patient to be loaded in to the patient data fields in the Patient Registration screen. The following patient registration fields will be populated with matching Worklist attributes:

**Table 3: Patient Registration fields populated from Worklist**

Data Field	DICOM Attribute	DICOM Tag
Name	Patient's Name	(0010,0010)
ID	Patient ID	(0010,0020)
Date of Birth	Patient's Birth Date	(0010,0030)
Sex	Patient's Sex	(0010,0040)
Height	Patient's Size	(0010,1020)
Weight	Patient's Weight	(0010,1030)
Institution Name	Institution name	(0008,0080)
Performing Physician	Performing Physicians' Name	(0008,1050)
Referring Physician	Referring Physician's Name	(0008,0090)
Operator	Operator's Name	(0008,1070)
Accession No.	Accession Number	(0008,0050)
Indication	Admitting Diagnoses Description	(0008,1080)
Request ID	Requested Procedure ID	(0040,1001)
Requested Procedure	Requested Procedure Description	(0032,1060)
	Scheduled Procedure Step Description	(0040,0007)
Additional Info	Additional Patient's History	(0010,21B0)

### 4.2.7 Modality Performed Procedure Step Real-World Activity

The Antares supports the DICOM Modality Performed Procedure Step Service as SCU. The modality performed procedure step SCU informs the performed procedure step SCP about the procedure performed at the modality using the N-CREATE and N-SET DIMSE service.

Immediately after a new patient, study or scheduled procedure is registered (via Patient Registration) the Antares automatically performs an MPPS N-CREATE-RQ operation with a status of IN-PROGRESS for the newly created Performed Procedure Step. When the current patient procedure ends, (either with an End Exam, or new Patient / Study / Procedure) the Antares automatically performs an MPPS N-SET-RQ final operation with a status of COMPLETED. The user may also manually complete or discontinue the current Performed Procedure Step through the MPPS dialog. An MPPS N-SET-RQ final operation is performed with the appropriate status of COMPLETED or DISCONTINUED.

The modality performed procedure step SCP responds to the N-CREATE-RQ and N-SET-RQ and confirms that it received the information from the modality.

### 4.2.8 Sequencing of Real-World Activities

In order for any of the remote processes to be able to provide the SCP services which the Antares system has requested, the appropriate associations must first be opened. This initiation occurs with the following activities:

1. When a “Send To Destination” operation occurs.
2. When one or more Storage SCP devices are configured for transfer “During the exam” and the associated Print/Store key(s) are pressed. The current image displayed on the system screen is captured and transferred.
3. When one or more Storage SCP devices are configured for transfer at “End of exam” and the current patient exam ends (e.g. New Patient, Study or End Exam button is pressed). All images in the current performed procedure are transferred.
4. When configured, Storage Commitment trigger is automatically derived from the successful completion of a Send Job.
5. When an “Expose Film Job” print operation occurs.
6. When one or more Print SCP devices are configured for transfer “During the exam” and the associated Print/Store key(s) are pressed. The current film sheet is transferred after becoming filled.
7. When one or more Print SCP devices are configured for transfer at “End of exam” and the patient procedure ends (e.g. New Patient, Study or End Exam button is pressed). All film sheets in the current performed procedure are transferred.
8. When user initiated or automatic Worklist query operations occur.
9. When configured, MPPS N-CREATE (status = IN PROGRESS) operation is automatically performed when a patient is successfully registered. A MPPS N-SET-RQ is automatically sent when the patient exam ends. The status will be set to COMPLETED or DISCONTINUED depending on the user selection.

## 5.0 AE Specifications

The following specifications apply to the AE as depicted in Figure 8: on page 13. The Antares AE provides conformance to the following DICOM Service SOP Classes as an SCU.

**Table 4: Supported SOP Classes**

Service SOP Class Name	SOP Class UID
Verification	1.2.840.10008.1.1
Ultrasound Image Storage	1.2.840.10008.5.1.4.1.1.6.1
Secondary Capture Image Storage	1.2.840.10008.5.1.4.1.1.7
Ultrasound Multi-frame Image Storage †	1.2.840.10008.5.1.4.1.1.3.1
Basic Grayscale Print Management Meta SOP Class	1.2.840.10008.5.1.1.9
Basic Color Print Management Meta SOP Class	1.2.840.10008.5.1.1.18
Print Job SOP Class	1.2.840.10008.5.1.1.14
Modality Worklist Information Model - FIND	1.2.840.10008.5.1.4.31
Storage Commitment - Push Model	1.2.840.10008.1.20.1
Comprehensive SR	1.2.840.10008.5.1.4.1.1.88.33
Modality Performed Procedure Step	1.2.840.10008.3.1.2.3.3

† The Ultrasound Multi-frame Image Storage SOP is used to transfer Antares Ultrasound clips & 3D volumetric data sets. When used for 3D volumetric data sets, each frame represents a single slice from the 3D volume. These 3D images may be viewed as Cine images.

### 5.1 Verification AE Specification

#### 5.1.1 Association Initiation by Real-World Activity

The Antares DICOM Service Tool application attempts to initiate a new association for DIMSE C-ECHO service related operations.

##### 5.1.1.1 Real-World Activity - Verification SCU/SCP

###### 5.1.1.1.1 Associated Real-World Activity - Associated Real-World Activity

The associated Real-World activity is a C-ECHO request initiated by the DICOM Service Tool application. If the process successfully establishes an association to a remote Application Entity, it will send the C-ECHO-Request via the open association to verify that the remote Application Entity is responding to DICOM messages. If a remote process successfully establishes an association, the Antares responds to C-ECHO-Requests made from remote applications.

**5.1.1.1.2 Proposed Presentation Contexts - Verification SCU/SCP**

The Antares DICOM application will propose Presentation Contexts as shown in the following table:

**Table 5: Verification Presentation Context Table**

Presentation Context Table					
Abstract Syntax		Transfer Syntax		Role	Extended Negotiation
Name	UID	Name List	UID List		
Verification	1.2.840.10008.1.1	Implicit VR Little Endian	1.2.840.10008.1.2	SCU / SCP	None
		Explicit VR Little Endian	1.2.840.10008.1.2.1		
		Explicit VR Big Endian	1.2.840.10008.1.2.2		

**5.1.1.1.3 SOP Specific Conformance Statement - Verification SCU/SCP**

The Antares conforms to the definition of a Verification SCU & SCP in accordance to the DICOM Standard.

**5.2 Storage AE Specification**

The Antares DICOM system provides Standard Conformance to the following DICOM V3.0 SOP Classes as an SCU.

**Table 6: Supported Storage SOP Classes**

Service SOP Class Name	SOP Class UID
Ultrasound Image Storage	1.2.840.10008.5.1.4.1.1.6.1
Secondary Capture Image Storage	1.2.840.10008.5.1.4.1.1.7
Ultrasound Multi-frame Image Storage	1.2.840.10008.5.1.4.1.1.3.1
Comprehensive SR	1.2.840.10008.5.1.4.1.1.88.33

This is accomplished using the DIMSE C-STORE Service to whom the SCU issues a service request with a SOP instance that meets the requirements of the desired ultrasound IOD.

**5.2.1 Association Establishment Policies**

**5.2.1.1 General**

The configuration of the Antares DICOM application defines the Application Entity Titles, the port numbers, the host names and IP addresses.

**5.2.1.2 Number of Associations**

The Antares DICOM application initiates several associations at a time, one for each destination to which a transfer request is being processed in the active job queue list.

**5.2.1.3 Asynchronous Nature**

The Antares DICOM software does not support asynchronous communication (multiple outstanding transactions over a single association).

#### **5.2.1.4 Implementation Identifying Information**

The Antares DICOM software provides a single Implementation Class UID of

- “1.3.12.2.1107.5.9.20000101”

and an Implementation Version Name of

- “SIEMENS\_SWFSYNGO”.

#### **5.2.1.5 Maximum PDU Size Offered**

The maximum PDU size offered by the Antares is configurable with default set to 28672 Bytes.

#### **5.2.1.6 DICOM Application Context**

DICOM Application context name: 1.2.840.10008.3.1.1.1

### **5.2.2 Association Initiation by Real-World Activity**

The Antares DICOM application attempts to initiate a new association for DIMSE C-STORE operation.

#### **5.2.2.1 Real World Activity - Storage SCU**

The user selects “New Patient” at the start of each new patient examination. The user saves images to the Antares hard disk with the “Store / Print” button.

##### **5.2.2.1.1 Associated Real World Activities - Storage SCU**

An association is established when the user initiates an “Archive to...” or “Send to...” destination operation from the Patient browser screen. Individual images or entire exams can be transferred to the selected DICOM Store device (C-STORE request). The association is opened when the first image of each exam is transferred and closed when the last image transfer is completed.

An association is also established when auto transfer has been configured and the user initiates a “Print/Store” operation. If transfer “during the exam” has been configured, an association is opened for each image acquired during the exam and closed when the image transfer is completed. If transfer at “end of exam” has been configured, an association is opened when the exam is completed (i.e. a new Patient / Study is registered or End Exam is performed). The association is closed when the last image transfer is completed.

If the C-STORE Response from the remote application contains an error status, the association is aborted.

##### **5.2.2.1.2 Proposed Presentation Context**

The following Presentation Context(s) is presented to the SCP in an A-Associate request for DIMSE C-STORE storage services. The storage services utilize C-STORE services, whose parameters are defined in PS 3.7.

**Table 7: Store Presentation Context Table**

Presentation Context Table					
Abstract Syntax		Transfer Syntax		Role	Extended Negotiation
Name	UID	Name List	UID List		
Ultrasound Image Storage	1.2.840.10008.5.1.4.1.1.6.1	Implicit VR Little Endian	1.2.840.10008.1.2	SCU	None
		Explicit VR Little Endian	1.2.840.10008.1.2.1	SCU	None
		Explicit VR Big Endian	1.2.840.10008.1.2.2	SCU	None
		JPEG Lossy (Baseline)	1.2.840.10008.1.2.4.50	SCU	None
		JPEG Lossless	1.2.840.10008.1.2.4.70	SCU	None
Secondary Capture Image Storage	1.2.840.10008.5.1.4.1.1.7	Implicit VR Little Endian	1.2.840.10008.1.2	SCU	None
		Explicit VR Little Endian	1.2.840.10008.1.2.1	SCU	None
		Explicit VR Big Endian	1.2.840.10008.1.2.2	SCU	None
		JPEG Lossy (Baseline)	1.2.840.10008.1.2.4.50	SCU	None
		JPEG Lossless	1.2.840.10008.1.2.4.70	SCU	None
† Ultrasound Multi-frame Image Storage (Clips)	1.2.840.10008.5.1.4.1.1.3.1	JPEG Lossy (Baseline)	1.2.840.10008.1.2.4.50	SCU	None
Ultrasound Multi-frame Image Storage (3D volumetric data sets)	1.2.840.10008.5.1.4.1.1.3.1	Implicit VR Little Endian	1.2.840.10008.1.2	SCU	None
		Explicit VR Little Endian	1.2.840.10008.1.2.1	SCU	None
		Explicit VR Big Endian	1.2.840.10008.1.2.2	SCU	None
		JPEG Lossy (Baseline)	1.2.840.10008.1.2.4.50	SCU	None
		JPEG Lossless	1.2.840.10008.1.2.4.70	SCU	None
Comprehensive SR	1.2.840.10008.5.1.4.1.1.88.33	Implicit VR Little Endian	1.2.840.10008.1.2	SCU	None
		Explicit VR Little Endian	1.2.840.10008.1.2.1	SCU	None

† The Antares stores clips locally using JPEG Lossy (Baseline) compression and only has access to the pixel data in lossy compressed form. Conversion to other transfer syntaxes is not supported.

**5.2.2.1.3 Photometric Interpretation**

Photometric Interpretation (color mode of the pixel image data) is not a negotiable parameter in DICOM 3.0. The Photometric Interpretation Attribute (0028,0004) is set depending on the transfer syntax, and the system configuration:

**Table 8: Photometric Interpretation**

SOP Class		Transfer Syntax		Photometric Interpretation
Name	UID	Name List	UID List	
Ultrasound Image Storage	1.2.840.10008.5.1.4.1.1.6.1	Implicit VR Little Endian	1.2.840.10008.1.2	RGB or MONOCHROME2 (if RGB to MONOCHROME is configured)
		Explicit VR Little Endian	1.2.840.10008.1.2.1	
		Explicit VR Big Endian	1.2.840.10008.1.2.2	
		JPEG Lossless	1.2.840.10008.1.2.4.70	
		JPEG Lossy (Baseline)	1.2.840.10008.1.2.4.50	YBR_FULL_422
Secondary Capture Image Storage	1.2.840.10008.5.1.4.1.1.7	Implicit VR Little Endian	1.2.840.10008.1.2	RGB or MONOCHROME2 (if RGB to MONOCHROME is configured)
		Explicit VR Little Endian	1.2.840.10008.1.2.1	
		Explicit VR Big Endian	1.2.840.10008.1.2.2	
		JPEG Lossless	1.2.840.10008.1.2.4.70	
		JPEG Lossy (Baseline)	1.2.840.10008.1.2.4.50	YBR_FULL_422
Ultrasound Multi-frame Image Storage (Clips)	1.2.840.10008.5.1.4.1.1.3.1	JPEG Lossy (Baseline)	1.2.840.10008.1.2.4.50	YBR_FULL_422
Ultrasound Multi-frame Image Storage (3D volumetric data sets)	1.2.840.10008.5.1.4.1.1.3.1	Implicit VR Little Endian	1.2.840.10008.1.2	MONOCHROME2
		Explicit VR Little Endian	1.2.840.10008.1.2.1	
		Explicit VR Big Endian	1.2.840.10008.1.2.2	
		JPEG Lossy (Baseline)	1.2.840.10008.1.2.4.50	
		JPEG Lossless	1.2.840.10008.1.2.4.70	

**5.2.2.1.4 SOP Specific Conformance to Storage Service SOP Classes**

The DICOM images created by the Antares DICOM application conform to the DICOM IOD definitions (Standard extended IODs). But they will contain additional private elements that may be discarded by a DICOM system when modifying the image.

Table 9: denotes the attributes included in the Ultrasound Image IOD as implemented on the Antares system. Attributes not listed are not used.

**Table 9: US Image IOD Attributes**

Module	Attribute	Tag	Type	Notes
Patient	Patient's Name	(0010,0010)	2	from MWL or user input
	Patient ID	(0010,0020)	2	from MWL or user input

Module	Attribute	Tag	Type	Notes
	Patient's Birth Date	(0010,0030)	2	from MWL or user input
	Patient's Sex	(0010,0040)	2	from MWL or user input
	Other Patient IDs	(0010,1000)	3	from MWL
	Other Patient Names	(0010,1001)	3	from MWL
	Ethnic Group	(0010,2160)	3	from MWL
	Patient Comments	(0010,4000)	3	from MWL
General Study	Study Instance UID	(0020,000D)	1	from MWL or created
	Study Date	(0008,0020)	2	created
	Study Time	(0008,0030)	2	created
	Referring Physician's Name	(0008,0090)	2	from MWL or user input
	Study ID	(0020,0010)	2	created
	Accession Number	(0008,0050)	2	from MWL or user input
	Study Description	(0008,1030)	3	From MWL (requested procedure description or scheduled procedure step description) or user selected
	Referenced Study Sequence	(0008,1110)	3	from MWL or zero length
	>Referenced SOP Class UID	(0008,1150)	1C	
	>Referenced SOP Instance UID	(0008,1155)	1C	
	Procedure Code Sequence	(0008,1032)	3	
> Include 'Code Sequence Macro'		3		
Patient Study	Admitting Diagnoses Description	(0008,1080)	3	from MWL or user input
	Patient's Age	(0010,1010)	3	calculated or user input
	Patient's Size	(0010,1020)	3	from MWL or user input
	Patient's Weight	(0010,1030)	3	from MWL or user input
	Additional Patient's History	(0010,21B0)	3	from MWL or user input
General Series	Modality	(0008,0060)	1	Set to US
	Series Instance UID	(0020,000E)	1	created
	Series Number	(0020,0011)	2	Set to 1...n
	Laterality	(0020,0060)	2C	Set to zero length
	Series Date	(0008,0021)	3	created
	Series Time	(0008,0031)	3	created
	Performing Physicians' Name	(0008,1050)	3	from MWL or user input
	Protocol Name	(0018,1030)	3	user input
	Series Description	(0008,103E)	3	user input
	Operators' Name	(0008,1070)	3	user input
	Referenced Study Component Sequence	(0008,1111)	3	created (if MPPS is supported)
	>Referenced SOP Class UID	(0008,1150)	1C	1.2.840.10008.3.1.2.3.3 (MPPS SOP Class)
	>Referenced SOP Instance UID	(0008,1155)	1C	MPPS SOP Instance UID
	Body Part Examined	(0018,0015)	3	user selected
Request Attributes Sequence	(0040,0275)	3	from MWL or zero length	

Module	Attribute	Tag	Type	Notes
	>Requested Procedure ID	(0040,1001)	1C	
	>Scheduled Procedure Step ID	(0040,0009)	1C	
	>Scheduled Procedure Step Description	(0040,0007)	3	
	>Scheduled Protocol Code Sequence	(0040,0008)	3	
	>>Include 'Code Sequence Macro'		3	
	Performed Procedure Step ID	(0040,0253)	3	from MWL Scheduled Procedure Step ID or created
	Performed Procedure Step Start Date	(0040,0244)	3	created
	Performed Procedure Step Start Time	(0040,0245)	3	created
	Performed Procedure Step Description	(0040,0254)	3	from MWL Scheduled Procedure Step Description or user input
	Performed Protocol Code Sequence	(0040,0260)	3	
	>Include 'Code Sequence Macro'		3	
	Comments on the Performed Procedure Step	(0040,0280)	3	from MPPS dialog
General Equipment	Manufacturer	(0008,0070)	2	Set to "Siemens Medical Systems - Ultrasound Division"
	Institution Name	(0008,0080)	3	from MWL or user selected
	Institution Address	(0008,0081)	3	from MWL
	Station Name	(0008,1010)	3	Set to the computer's host name
	Manufacturer's Model Name	(0008,1090)	3	Set to "Antares"
	Device Serial Number	(0018,1000)	3	Set to system serial number
	Software Versions	(0018,1020)	3	Set to "200.0.086 (VE31F SL04P09)"
General Image	Instance Number	(0020,0013)	2	1...n
	Patient Orientation	(0020,0020)	2C	Set to zero length
	Acquisition Date	(0008,0022)	2	created
	Content Date	(0008,0023)	2C	created
	Acquisition Time	(0008,0032)	3	created
	Content Time	(0008,0033)	2C	created
	Derivation Description	(0008,2111)	3	Compress BN JPEG Lossy (xx/xxx.xx). Used if JPEG Lossy compression is applied.  Set to: Force Owner CSA-DICOM, CONVERT RGB, US to MONOCHROME2 when RGB to MONOCHROME2 is configured for remote destination.
	Source Image Sequence	(0008,2112)	3	Used if 3D rendering to reference 3D Volume.
	>Referenced SOP Class UID	(0008,1150)	1C	
	>Referenced SOP Instance UID	(0008,1155)	1C	

Module	Attribute	Tag	Type	Notes
	>Referenced Frame Number	(0008,1160)	3	
	Image Comments	(0020,4000)	3	user input
	Lossy Image Compression Ratio	(0028,2112)	3	Only used with JPEG Lossy compression
Image Pixel	Rows	(0028,0010)	1	Set to 768
	Columns	(0028,0011)	1	Set to 1024
	Pixel Data	(7FE0,0010)	1	
US Region Calibration	Sequence of Ultrasound Regions	(0018,6011)	1	one created for each US region displayed
	>Region Spatial Format	(0018,6012)	1	
	>Region Data Type	(0018,6014)	1	
	>Region Flags	(0018,6016)	1	
	>Region Location Min x0	(0018,6018)	1	
	>Region Location Min y0	(0018,601A)	1	
	>Region Location Max x1	(0018,601C)	1	
	>Region Location Max y1	(0018,601E)	1	
	>Reference Pixel x0	(0018,6020)	3	
	>Reference Pixel y0	(0018,6022)	3	
	>Physical Units X Direction	(0018,6024)	1	
	>Physical Units Y Direction	(0018,6026)	1	
	>Ref. Pixel Physical Value X	(0018,6028)	3	
	>Ref. Pixel Physical Value Y	(0018,602A)	3	
	>Physical Delta X	(0018,602C)	1	
	>Physical Delta Y	(0018,602E)	1	
>Transducer Frequency	(0018,6030)	3		
>Pulse Repetition Frequency	(0018,6032)	3	Color Flow and Doppler regions only	
>Doppler Correction Angle	(0018,6034)	3	Doppler regions only	
US Image Module	Samples Per Pixel	(0028,0002)	1	Set to 3.  Set to 1 if RGB to MONOCROME2 is Configured for remote Destination.
	Photometric Interpretation	(0028,0004)	1	See Table 8:
	Bits Allocated	(0028,0100)	1	Set to 8
	Bits Stored	(0028,0101)	1	Set to 8
	High Bit	(0028,0102)	1	Set to 7
	Planar Configuration	(0028,0006)	1C	Set to 0 (color-by-pixel)
	Ultrasound Color Data Present	(0028,0014)	1C	Set to 1 if Color Flow or Pseudo Color in image
	Pixel Representation	(0028,0103)	1	Set to 0 (unsigned integer)

Module	Attribute	Tag	Type	Notes
	Image Type	(0008,0008)	2	Normally ORIGINAL/PRIMARY.  Set to DERIVED/PRIMARY if RGB to MONOCHROME2 is configured for remote destination.
	Lossy Image Compression	(0028,2110)	1C	= 01 if JPEG lossy compressed
	Transducer Data	(0018,5010)	3	Probe name (e.g. C5-2)
	Mechanical Index	(0018,5022)	3	B-mode only
	Bone Thermal Index	(0018,5024)	3	Doppler, M-Mode & Color Flow only
	Cranial Thermal Index	(0018,5026)	3	Cranial Doppler only
	Soft Tissue Thermal Index	(0018,5027)	3	Doppler, M-Mode & Color Flow only
Overlay Plane (not included if burned in graphics is selected)	Overlay Rows	(60xx,0010)	1	Set to 768
	Overlay Columns	(60xx,0011)	1	Set to 1024
	Overlay Type	(60xx,0040)	1	Set to G
	Overlay Origin	(60xx,0050)	1	Set to 1\1
	Overlay Bits Allocated	(60xx,0100)	1	Set to 1
	Overlay Bit Position	(60xx,0102)	1	Set to 0
	Overlay Data	(60xx,3000)	1C	
	Overlay Description	(60xx,0022)	3	Set to "Siemens MedCom Object Graphics"
SOP Common	SOP Class UID	(0008,0016)	1	1.2.840.10008.5.1.4.1.1.6.1
	SOP Instance UID	(0008,0018)	1	created
	Specific Character Set	(0008,0005)	1C	From MWL or set to ISO_IR 100
	Instance Creation Date	(0008,0012)	3	created
	Instance Creation Time	(0008,0013)	3	created
<b>Standard Extended SOP Class - Standard and Private Attributes</b>				
Patient Demographic	Patient's Address	(0010,1040)	3	from MWL
	Military Rank	(0010,1080)	3	from MWL
Patient Medical	Medical Alerts	(0010,2000)	3	from MWL
	Contrast Allergies	(0010,2110)	3	from MWL
	Smoking Status	(0010,21A0)	3	from MWL
	Pregnancy Status	(0010,21C0)	3	from MWL
	Last Menstrual Date	(0010,21D0)	3	from MWL or input by user
	Special Needs	(0038,0050)	3	from MWL
	Patient State	(0038,0500)	3	from MWL

Module	Attribute	Tag	Type	Notes
Image Plane	Pixel Spacing	(0028,0030)	3	This attribute is not included in images that contain Doppler or M-Mode data, or images that contain more than one 2D tissue region.
Study Scheduling	Requesting Physician	(0032,1032)	3	from MWL
	Requesting Service	(0032,1033)	3	from MWL
	Requested Procedure Description	(0032,1060)	3	from MWL
	Requested Procedure Code Sequence	(0032,1064)	3	from MWL
	>Include 'Code Sequence Macro'		3	
Study Classification	Study Comments	(0032,4000)	3	input by user
Multi-Frame Overlay	Number of Frames in Overlay	(60xx,0015)	3	Set to 1 (only used if overlay is present)
	Image Frame Origin	(60xx,0051)	3	Set to 1 (only used if overlay is present)
Antares Private Attributes	Private Creator	(0019,0001)	3	SIEMENS MED SMS USG ANTARES
	Private Creator Version	(0019,1000)	3	1.1
	Frame Rate	(0019,1003)	3	in fps
	Burned in Graphics	(0019,100C)	3	0 = Overlay, 1 = Graphics burned into pixel data
	SieClear Index	(0019,100D)	3	Off, 1, 2, 3, 4
	B-Mode Submode	(0019,1020)	3	GEN, THI, etc.
	B-Mode Dynamic Range	(0019,1021)	3	in dB
	B-Mode Overall Gain	(0019,1022)	3	in dB
	B-Mode Res/Speed Index	(0019,1023)	3	Resolution Vs. Speed
	B-Mode Edge Enhance Index	(0019,1024)	3	
	B-Mode Persistence Index	(0019,1025)	3	
	B-Mode Map Index	(0019,1026)	3	
	B-Mode Tint Type	(0019,102A)	3	0 = Grayscale, 1 = Color Balance, 2 = Pseudo Color
	B-Mode Tint Index	(0019,102D)	3	
	ClarifyVE Index	(0019,102E)	3	Off, 1, 2, 3, 4, 5, 6, 7
	Image Flag	(0019,103A)	3	1 = flagged image, 0 (or not present) = not flagged
	Color Flow state	(0019,1040)	3	Low, Gen, High
	Color Flow Wall Filter Index	(0019,1041)	3	
	Color Flow Submode	(0019,1042)	3	Power, CDV, CDE, VEL
	Color Flow Overall Gain	(0019,1043)	3	in dB
Color Flow Res/Speed Index	(0019,1044)	3		
Color Flow Smooth Index	(0019,1046)	3		

Module	Attribute	Tag	Type	Notes
	Color Flow Persistence Index	(0019,1047)	3	
	Color Flow Map Index	(0019,1048)	3	
	Color Flow Priority Index	(0019,1049)	3	
	Color Flow Maximum Velocity	(0019,1054)	3	in cm/sec
	Doppler Dynamic Range	(0019,1060)	3	in dB
	Doppler Overall Gain	(0019,1061)	3	in dB
	Doppler Wall Filter	(0019,1062)	3	in Hz
	Doppler Gate Size	(0019,1063)	3	in mm
	Doppler Map Index	(0019,1065)	3	
	Doppler Submode	(0019,1066)	3	PW, CW, etc.
	Doppler Time/Freq Res Index	(0019,1069)	3	
	Doppler Trace Inverted	(0019,106A)	3	0, 1
	Doppler Tint Type	(0019,106C)	3	0 = Grayscale, 1 = Color Balance, 2 = Pseudo Color
	Doppler Tint Index	(0019,1072)	3	
	M-Mode Dynamic Range	(0019,1080)	3	in dB
	M-Mode Overall Gain	(0019,1081)	3	in dB
	M-Mode Edge Enhance Index	(0019,1082)	3	
	M-Mode Map Index	(0019,1083)	3	
	M-Mode Tint Type	(0019,1086)	3	0 = Grayscale, 1 = Color Balance, 2 = Pseudo Color
	M-Mode Submode	(0019,1087)	3	GEN
	M-Mode Tint Index	(0019,1088)	3	
MedCom Private Attributes †	MedCom Header Info - Private Creator	(0029,0010)	3	SIEMENS MEDCOM HEADER
	MedCom Header data	(0029,1020)	3	
	PMTF Information 1	(0029,1031)	3	
	PMTF Information 2	(0029,1032)	3	
	PMTF Information 3	(0029,1033)	3	
	PMTF Information 4	(0029,1034)	3	DB TO DICOM
MedCom Private Attributes †	MedCom OOG - Private Creator	(0029,0011)	3	SIEMENS MEDCOM OOG
	MedCom OOG Type	(0029,1108)	3	MEDCOM OOG 2
	MedCom OOG Version	(0029,1109)	3	VE31F
	MedCom OOG Info	(0029,1110)	3	

† The ACUSON Antares system uses syngo MedCom private elements. These private elements are used between the Antares AE and other syngo based AE's to describe Object Oriented Graphics (OOG). This module is used when object graphics are drawn on the image and stores the properties of the graphics objects (Line, Circle, Rectangle, Arrows, etc.). The graphics objects will remain re-animate-able even if such an image is transferred via the DICOM C-Store SOP Class. The graphics objects may also be stored in a single image overlay plane for compatibility with other products which don't support the OOG module. These private elements should be discarded by non-syngo based DICOM application entities when modifying the image overlay data.

Table 10: denotes the attributes included in the Secondary Capture Image IOD as implemented on the Antares system. Attributes not listed are not used.

**Table 10: Secondary Capture IOD Attributes**

Module	Attribute	Tag	Type	Notes
Patient	Patient's Name	(0010,0010)	2	from MWL or user input
	Patient ID	(0010,0020)	2	from MWL or user input
	Patient's Birth Date	(0010,0030)	2	from MWL or user input
	Patient's Sex	(0010,0040)	2	from MWL or user input
	Other Patient IDs	(0010,1000)	3	from MWL
	Other Patient Names	(0010,1001)	3	from MWL
	Ethnic Group	(0010,2160)	3	from MWL
	Patient Comments	(0010,4000)	3	from MWL
General Study	Study Instance UID	(0020,000D)	1	from MWL or created
	Study Date	(0008,0020)	2	created
	Study Time	(0008,0030)	2	created
	Referring Physician's Name	(0008,0090)	2	from MWL or user input
	Study ID	(0020,0010)	2	created
	Accession Number	(0008,0050)	2	from MWL or user input
	Study Description	(0008,1030)	3	from MWL (requested procedure description or scheduled procedure step description) or user selected
	Referenced Study Sequence	(0008,1110)	3	from MWL or zero length
	>Referenced SOP Class UID	(0008,1150)	1C	
	>Referenced SOP Instance UID	(0008,1155)	1C	
	Procedure Code Sequence	(0008,1032)	3	
	> Include 'Code Sequence Macro'		3	
Patient Study	Admitting Diagnoses Description	(0008,1080)	3	from MWL or user input
	Patient's Age	(0010,1010)	3	calculated or user input
	Patient's Size	(0010,1020)	3	from MWL or user input
	Patient's Weight	(0010,1030)	3	from MWL or user input
Patient Study	Additional Patient's History	(0010,21B0)	3	from MWL or user input
General Series	Series Instance UID	(0020,000E)	1	created
	Series Number	(0020,0011)	2	Set to 1...n
	Laterality	(0020,0060)	2C	Set to zero length
	Series Date	(0008,0021)	3	created
	Series Time	(0008,0031)	3	created
	Performing Physicians' Name	(0008,1050)	3	from MWL or user input
	Protocol Name	(0018,1030)	3	user input
	Series Description	(0008,103E)	3	user input
	Operators' Name	(0008,1070)	3	user input
Referenced Study Component Sequence	(0008,1111)	3	created (if MPPS is supported)	

Module	Attribute	Tag	Type	Notes
	>Referenced SOP Class UID	(0008,1150)	1C	1.2.840.10008.3.1.2.3.3 (MPPS SOP Class)
	>Referenced SOP Instance UID	(0008,1155)	1C	MPPS SOP Instance UID
	Body Part Examined	(0018,0015)	3	user selected
	Request Attributes Sequence	(0040,0275)	3	from MWL or zero length
	>Requested Procedure ID	(0040,1001)	1C	
	>Scheduled Procedure Step ID	(0040,0009)	1C	
	>Scheduled Procedure Step Description	(0040,0007)	3	
	>Scheduled Protocol Code Sequence	(0040,0008)	3	
	>>Include 'Code Sequence Macro'		3	
	Performed Procedure Step ID	(0040,0253)	3	from MWL Scheduled Procedure Step ID or created
	Performed Procedure Step Start Date	(0040,0244)	3	created
	Performed Procedure Step Start Time	(0040,0245)	3	created
	Performed Procedure Step Description	(0040,0254)	3	from MWL Scheduled Procedure Step Description or user input
	Performed Protocol Code Sequence	(0040,0260)	3	
	>Include 'Code Sequence Macro'		3	
	Comments on the Performed Procedure Step	(0040,0280)	3	from MPPS dialog
General Equipment	Manufacturer	(0008,0070)	2	Set to "Siemens Medical Systems - Ultrasound Division"
	Institution Name	(0008,0080)	3	from MWL or user selected
	Institution Address	(0008,0081)	3	from MWL
	Station Name	(0008,1010)	3	Set to the computer's host name
	Manufacturer's Model Name	(0008,1090)	3	Set to "Antares"
	Device Serial Number	(0018,1000)	3	Set to system serial number
	Software Versions	(0018,1020)	3	Set to "200.0.086 (VE31F SL04P09)"
SC Equipment	Conversion Type	(0008,0064)	1	Set to WSD
	Modality	(0008,0060)	3	Set to US
General Image	Instance Number	(0020,0013)	2	1...n
	Patient Orientation	(0020,0020)	2C	Set to zero length
	Content Date	(0008,0023)	2C	created
	Content Time	(0008,0033)	2C	created
	Image Type	(0008,0008)	3	ORIGINAL/PRIMARY
	Acquisition Date	(0008,0022)	2	created
	Acquisition Time	(0008,0032)	3	created
	Derivation Description	(0008,2111)	3	Compress BN JPEG Lossy (xx/xxx.xx). Only used with JPEG Lossy compression.
Image Comments	(0020,4000)	3	user input	

Module	Attribute	Tag	Type	Notes
	Lossy Image Compression	(0028,2110)	1C	= 01 if JPEG Lossy compression
	Lossy Image Compression Ratio	(0028,2112)	3	Only used with JPEG Lossy compression
Image Pixel	Samples Per Pixel	(0028,0002)	1	Set to 3
	Photometric Interpretation	(0028,0004)	1	See Table 8:
	Rows	(0028,0010)	1	Set to 768
	Columns	(0028,0011)	1	Set to 1024
	Bits Allocated	(0028,0100)	1	Set to 8
	Bits Stored	(0028,0101)	1	Set to 8
	High Bit	(0028,0102)	1	Set to 7
	Pixel Representation	(0028,0103)	1	Set to 0 (unsigned integer)
	Pixel Data	(7FE0,0010)	1	
SOP Common	Planar Configuration	(0028,0006)	1C	Set to 0 (color-by-pixel)
	SOP Class UID	(0008,0016)	1	1.2.840.10008.5.1.4.1.1.7
	SOP Instance UID	(0008,0018)	1	created
	Specific Character Set	(0008,0005)	1C	From MWL or set to ISO_IR 100
	Instance Creation Date	(0008,0012)	3	created
	Instance Creation Time	(0008,0013)	3	created
<b>Standard Extended SOP Class - Standard and Private Attributes</b>				
Patient Demographic	Patient's Address	(0010,1040)	3	from MWL
	Military Rank	(0010,1080)	3	from MWL
Patient Medical	Medical Alerts	(0010,2000)	3	from MWL
	Contrast Allergies	(0010,2110)	3	from MWL
	Smoking Status	(0010,21A0)	3	from MWL
	Pregnancy Status	(0010,21C0)	3	from MWL
	Last Menstrual Date	(0010,21D0)	3	from MWL or input by user
	Special Needs	(0038,0050)	3	from MWL
	Patient State	(0038,0500)	3	from MWL
Study Scheduling	Requesting Physician	(0032,1032)	3	from MWL
	Requesting Service	(0032,1033)	3	from MWL
	Requested Procedure Description	(0032,1060)	3	from MWL
	Requested Procedure Code Sequence	(0032,1064)	3	from MWL
	>Include 'Code Sequence Macro'		3	
Study Classification	Study Comments	(0032,4000)	3	input by user
MedCom Private Attributes †	MedCom Header Info - Private Creator	(0029,0010)	3	SIEMENS MEDCOM HEADER
	MedCom Header data	(0029,1020)	3	
	PMTF Information 1	(0029,1031)	3	
	PMTF Information 2	(0029,1032)	3	

Module	Attribute	Tag	Type	Notes
	PMTF Information 3	(0029,1033)	3	
	PMTF Information 4	(0029,1034)	3	DB TO DICOM
	MedCom OOG - Private Creator	(0029,0011)	3	SIEMENS MEDCOM OOG
	MedCom OOG Type	(0029,1108)	3	MEDCOM OOG 2
	MedCom OOG Version	(0029,1109)	3	VE31F
	MedCom OOG Info	(0029,1110)	3	

Table 11: denotes the attributes included in the Ultrasound Multi-frame Image IOD as implemented on the Antares system, when used for Clip images. Attributes not listed are not used.

**Table 11: US-MF IOD Attributes – Clips**

Module	Attribute	Tag	Type	Notes
Patient	Patient's Name	(0010,0010)	2	from MWL or user input
	Patient ID	(0010,0020)	2	from MWL or user input
	Patient's Birth Date	(0010,0030)	2	from MWL or user input
	Patient's Sex	(0010,0040)	2	from MWL or user input
	Other Patient IDs	(0010,1000)	3	from MWL
	Other Patient Names	(0010,1001)	3	from MWL
	Ethnic Group	(0010,2160)	3	from MWL
	Patient Comments	(0010,4000)	3	from MWL
General Study	Study Instance UID	(0020,000D)	1	from MWL or created
	Study Date	(0008,0020)	2	created
	Study Time	(0008,0030)	2	created
	Referring Physician's Name	(0008,0090)	2	from MWL or user input
	Study ID	(0020,0010)	2	created
	Accession Number	(0008,0050)	2	from MWL or user input
	Study Description	(0008,1030)	3	from MWL (requested procedure description or scheduled procedure step description) or user selected
	Referenced Study Sequence	(0008,1110)	3	from MWL or zero length
	>Referenced SOP Class UID	(0008,1150)	1C	
	>Referenced SOP Instance UID	(0008,1155)	1C	
	Procedure Code Sequence	(0008,1032)	3	
	> Include 'Code Sequence Macro'		3	
Patient Study	Admitting Diagnoses Description	(0008,1080)	3	from MWL or user input
	Patient's Age	(0010,1010)	3	calculated or user input
	Patient's Size	(0010,1020)	3	from MWL or user input
	Patient's Weight	(0010,1030)	3	from MWL or user input
	Additional Patient's History	(0010,21B0)	3	from MWL or user input
General Series	Modality	(0008,0060)	1	Set to US

Module	Attribute	Tag	Type	Notes
	Series Instance UID	(0020,000E)	1	created
	Series Number	(0020,0011)	2	Set to 1...n
	Laterality	(0020,0060)	2C	Set to zero length
	Series Date	(0008,0021)	3	created
	Series Time	(0008,0031)	3	created
	Performing Physicians' Name	(0008,1050)	3	from MWL or user input
	Protocol Name	(0018,1030)	3	user input
	Series Description	(0008,103E)	3	user input
	Operators' Name	(0008,1070)	3	user input
	Referenced Study Component Sequence	(0008,1111)	3	created (if MPPS is supported)
	>Referenced SOP Class UID	(0008,1150)	1C	1.2.840.10008.3.1.2.3.3 (MPPS SOP Class)
	>Referenced SOP Instance UID	(0008,1155)	1C	MPPS SOP Instance UID
	Body Part Examined	(0018,0015)	3	user selected
	Request Attributes Sequence	(0040,0275)	3	from MWL or zero length
	>Requested Procedure ID	(0040,1001)	1C	
	>Scheduled Procedure Step ID	(0040,0009)	1C	
	>Scheduled Procedure Step Description	(0040,0007)	3	
	>Scheduled Protocol Code Sequence	(0040,0008)	3	
	>>Include 'Code Sequence Macro'		3	
	Performed Procedure Step ID	(0040,0253)	3	from MWL Scheduled Procedure Step ID or created
	Performed Procedure Step Start Date	(0040,0244)	3	created
	Performed Procedure Step Start Time	(0040,0245)	3	created
	Performed Procedure Step Description	(0040,0254)	3	from MWL Scheduled Procedure Step Description or user input
	Performed Protocol Code Sequence	(0040,0260)	3	
>Include 'Code Sequence Macro'		3		
Comments on the Performed Procedure Step	(0040,0280)	3	from MPPS dialog	
General Equipment	Manufacturer	(0008,0070)	2	Set to "Siemens Medical Systems – Ultrasound Division"
	Institution Name	(0008,0080)	3	from MWL or user selected
	Institution Address	(0008,0081)	3	from MWL
	Station Name	(0008,1010)	3	Set to the computer's host name
	Manufacturer's Model Name	(0008,1090)	3	Set to "Antares"
	Device Serial Number	(0018,1000)	3	Set to system serial number
	Software Versions	(0018,1020)	3	Set to "200.0.086 (VE31F SL04P09)"
General Image	Instance Number	(0020,0013)	2	1...n
	Patient Orientation	(0020,0020)	2C	Set to zero length
	Content Date	(0008,0023)	2C	created

Module	Attribute	Tag	Type	Notes
	Content Time	(0008,0033)	2C	created
	Acquisition Date	(0008,0022)	2	created
	Acquisition Time	(0008,0032)	3	created
	Acquisition Datetime	(0008,002A)	3	created
	Derivation Description	(0008,2111)	3	Compress BN JPEG Lossy (xx) where (xx) is the compression ratio.
	Image Comments	(0020,4000)	3	user input
	Lossy Image Compression Ratio	(0028,2112)	3	Only used with JPEG Lossy compression
Image Pixel	Rows	(0028,0010)	1	Set to 600
	Columns	(0028,0011)	1	Set to 800
	Pixel Data	(7FE0,0010)	1	
Cine	Frame Time Vector	(0018,1065)	1C	1 to Number of Frames
Multi-Frame	Number of Frames	(0028,0008)	1	
US Region Calibration	Sequence of Ultrasound Regions	(0018,6011)	1	one created for each US region displayed
	>Region Spatial Format	(0018,6012)	1	
	>Region Data Type	(0018,6014)	1	
	>Region Flags	(0018,6016)	1	
	>Region Location Min x0	(0018,6018)	1	
	>Region Location Min y0	(0018,601A)	1	
	>Region Location Max x1	(0018,601C)	1	
	>Region Location Max y1	(0018,601E)	1	
	>Reference Pixel x0	(0018,6020)	3	
	>Reference Pixel y0	(0018,6022)	3	
	>Physical Units X Direction	(0018,6024)	1	
	>Physical Units Y Direction	(0018,6026)	1	
	>Ref. Pixel Physical Value X	(0018,6028)	3	
	>Ref. Pixel Physical Value Y	(0018,602A)	3	
	>Physical Delta X	(0018,602C)	1	
	>Physical Delta Y	(0018,602E)	1	
	>Transducer Frequency	(0018,6030)	3	
>Pulse Repetition Frequency	(0018,6032)	3	Color Flow and Doppler regions only	
>Doppler Correction Angle	(0018,6034)	3	Doppler regions only	
US Image Module	Samples Per Pixel	(0028,0002)	1	Set to 3 Set to 1 if RGB to MONOCHROME2 is Configured for remote destination
	Photometric Interpretation	(0028,0004)	1	See Table 8:
	Bits Allocated	(0028,0100)	1	Set to 8

Module	Attribute	Tag	Type	Notes
	Bits Stored	(0028,0101)	1	Set to 8
	High Bit	(0028,0102)	1	Set to 7
	Planar Configuration	(0028,0006)	1C	Set to 0 (color-by-pixel)
	Ultrasound Color Data Present	(0028,0014)	1C	Set to 1 if Color Flow or Pseudo Color in image
	Pixel Representation	(0028,0103)	1	Set to 0 (unsigned integer)
	Frame Increment Pointer	(0028,0009)	1C	Sequencing by Frame Time Vector (0018,1065)
	Image Type	(0008,0008)	2	DERIVED / PRIMARY
	Lossy Image Compression	(0028,2110)	1C	Set to 01
	Transducer Data	(0018,5010)	3	Probe name (e.g. C5-2)
	Mechanical Index	(0018,5022)	3	B-mode only
	Bone Thermal Index	(0018,5024)	3	Doppler, M-Mode & Color Flow only
	Cranial Thermal Index	(0018,5026)	3	Cranial Doppler only
	Soft Tissue Thermal Index	(0018,5027)	3	Doppler, M-Mode & Color Flow only
SOP Common	SOP Class UID	(0008,0016)	1	1.2.840.10008.5.1.4.1.1.6.1
	SOP Instance UID	(0008,0018)	1	created
	Specific Character Set	(0008,0005)	1C	From MWL or set to ISO_IR 100
	Instance Creation Date	(0008,0012)	3	created
	Instance Creation Time	(0008,0013)	3	created
<b>Standard Extended SOP Class - Standard and Private Attributes</b>				
Patient Demographic	Patient's Address	(0010,1040)	3	from MWL
	Military Rank	(0010,1080)	3	from MWL
Patient Medical	Medical Alerts	(0010,2000)	3	from MWL
	Contrast Allergies	(0010,2110)	3	from MWL
	Smoking Status	(0010,21A0)	3	from MWL
	Pregnancy Status	(0010,21C0)	3	from MWL
	Last Menstrual Date	(0010,21D0)	3	from MWL or input by user
	Special Needs	(0038,0050)	3	from MWL
	Patient State	(0038,0500)	3	from MWL
Image Plane	Pixel Spacing	(0028,0030)	3	This attribute is not included in images that contain Doppler or M-Mode data, or images that contain more than one 2D tissue region.
Study Scheduling	Requesting Physician	(0032,1032)	3	from MWL
	Requesting Service	(0032,1033)	3	from MWL
	Requested Procedure Description	(0032,1060)	3	from MWL
	Requested Procedure Code Sequence	(0032,1064)	3	from MWL
	>Include 'Code Sequence Macro'		3	

Module	Attribute	Tag	Type	Notes
Study Classification	Study Comments	(0032,4000)	3	input by user
Antares Private Attributes	Private Creator	(0019,00xx)	3	SIEMENS MED SMS USG ANTARES
	Private Creator Version	(0019,xx00)	3	1.1
	B-Mode Tint Type	(0019,xx2A)	3	0 = Grayscale , 1 = Color Balance , 2 = Pseudo Color
	B-Mode Tint Index	(0019,xx2D)	3	
	Image Flag	(0019,xx3A)	3	1 = flagged image, 0 (or not present) = not flagged
	Doppler Tint Type	(0019,xx6C)	3	0 = Grayscale , 1 = Color Balance , 2 = Pseudo Color
	M-Mode Tint Type	(0019,xx86)	3	0 = Grayscale , 1 = Color Balance , 2 = Pseudo Color
MedCom Private Attributes †	MedCom Header Info - Private Creator	(0029,0010)	3	SIEMENS MEDCOM HEADER
	MedCom Header data	(0029,1020)	3	
	PMTF Information 1	(0029,1031)	3	
	PMTF Information 2	(0029,1032)	3	
	PMTF Information 3	(0029,1033)	3	
	PMTF Information 4	(0029,1034)	3	DB TO DICOM
	MedCom OOG - Private Creator	(0029,0011)	3	SIEMENS MEDCOM OOG
	MedCom OOG Type	(0029,1108)	3	MEDCOM OOG 2
	MedCom OOG Version	(0029,1109)	3	VE31F
	MedCom OOG Info	(0029,1110)	3	

Table 12: denotes the attributes included in the Ultrasound Multi-Frame Image IOD as implemented on the Antares system, when used for 3D volumetric data sets. Attributes not listed are not used. Each frame represents a single slice from the 3D volume.

**Table 12: US-MF Image IOD Attributes - 3D Volumetric Data**

Module	Attribute	Tag	Type	Notes
Patient	Patient's Name	(0010,0010)	2	from MWL or user input
	Patient ID	(0010,0020)	2	from MWL or user input
	Patient's Birth Date	(0010,0030)	2	from MWL or user input
	Patient's Sex	(0010,0040)	2	from MWL or user input
	Other Patient IDs	(0010,1000)	3	from MWL
	Other Patient Names	(0010,1001)	3	from MWL
	Ethnic Group	(0010,2160)	3	from MWL
	Patient Comments	(0010,4000)	3	from MWL

Module	Attribute	Tag	Type	Notes
General Study	Study Instance UID	(0020,000D)	1	from MWL or created
	Study Date	(0008,0020)	2	created
	Study Time	(0008,0030)	2	created
	Referring Physician's Name	(0008,0090)	2	from MWL or user input
	Study ID	(0020,0010)	2	created
	Accession Number	(0008,0050)	2	from MWL or user input
	Study Description	(0008,1030)	3	from MWL (requested procedure description or scheduled procedure step description) or user selected
	Referenced Study Sequence	(0008,1110)	3	from MWL or zero length
	>Referenced SOP Class UID	(0008,1150)	1C	
	>Referenced SOP Instance UID	(0008,1155)	1C	
	Procedure Code Sequence	(0008,1032)	3	
	> Include 'Code Sequence Macro'		3	
	Patient Study	Admitting Diagnoses Description	(0008,1080)	3
Patient's Age		(0010,1010)	3	calculated or user input
Patient's Size		(0010,1020)	3	from MWL or user input
Patient's Weight		(0010,1030)	3	from MWL or user input
Additional Patient's History		(0010,21B0)	3	from MWL or user input
General Series	Modality	(0008,0060)	1	Set to US
	Series Instance UID	(0020,000E)	1	created
	Series Number	(0020,0011)	2	Set to 1...n
	Laterality	(0020,0060)	2C	Set to zero length
	Series Date	(0008,0021)	3	created
	Series Time	(0008,0031)	3	created
	Performing Physicians' Name	(0008,1050)	3	from MWL or user input
	Protocol Name	(0018,1030)	3	user input
	Series Description	(0008,103E)	3	user input
	Operators' Name	(0008,1070)	3	user input
	Referenced Study Component Sequence	(0008,1111)	3	created (if MPPS is supported)
	>Referenced SOP Class UID	(0008,1150)	1C	1.2.840.10008.3.1.2.3.3 (MPPS SOP Class)
	>Referenced SOP Instance UID	(0008,1155)	1C	MPPS SOP Instance UID
	Body Part Examined	(0018,0015)	3	user selected
	Request Attributes Sequence	(0040,0275)	3	from MWL or zero length
	>Requested Procedure ID	(0040,1001)	1C	
	>Scheduled Procedure Step ID	(0040,0009)	1C	
	>Scheduled Procedure Step Description	(0040,0007)	3	
	>Scheduled Protocol Code Sequence	(0040,0008)	3	
	>>Include 'Code Sequence Macro'		3	

Module	Attribute	Tag	Type	Notes
	Performed Procedure Step ID	(0040,0253)	3	from MWL Scheduled Procedure Step ID or created
	Performed Procedure Step Start Date	(0040,0244)	3	created
	Performed Procedure Step Start Time	(0040,0245)	3	created
	Performed Procedure Step Description	(0040,0254)	3	from MWL Scheduled Procedure Step Description or user input
	Performed Protocol Code Sequence	(0040,0260)	3	
	>Include 'Code Sequence Macro'		3	
	Comments on the Performed Procedure Step	(0040,0280)	3	from MPPS dialog
General Equipment	Manufacturer	(0008,0070)	2	Set to "Siemens Medical Systems - Ultrasound Division"
	Institution Name	(0008,0080)	3	from MWL or user selected
	Institution Address	(0008,0081)	3	from MWL
	Station Name	(0008,1010)	3	Set to the computer's host name
	Manufacturer's Model Name	(0008,1090)	3	Set to "Antares"
	Device Serial Number	(0018,1000)	3	Set to system serial number
	Software Versions	(0018,1020)	3	Set to "200.0.086 (VE31F SL04P09)"
General Image	Instance Number	(0020,0013)	2	1...n
	Patient Orientation	(0020,0020)	2C	Set to zero length
	Acquisition Date	(0008,0022)	2	created
	Acquisition Time	(0008,0032)	3	created
	Acquisition Datetime	(0008,002A)	3	created
	Derivation Description	(0008,2111)	3	US_3D_VOLUME_DATA
	Image Comments	(0020,4000)	3	user input
	Lossy Image Compression Ratio	(0028,2112)	3	Only used with JPEG Lossy compression
Image Pixel	Rows	(0028,0010)	1	Set to 600
	Columns	(0028,0011)	1	Set to 800
	Pixel Data	(7FE0,0010)	1	
US Image Module	Samples Per Pixel	(0028,0002)	1	Set to 1
	Photometric Interpretation	(0028,0004)	1	See Table 8:
	Bits Allocated	(0028,0100)	1	Set to 8
	Bits Stored	(0028,0101)	1	Set to 8
	High Bit	(0028,0102)	1	Set to 7
	Ultrasound Color Data Present	(0028,0014)	1C	Set to 1 if Color Flow or Pseudo Color is present in the image
	Frame Increment Pointer	(0028,0009)	1C	Set to 0018,1063 (Frame Time attribute)
	Pixel Representation	(0028,0103)	1	Set to 0 (unsigned integer)
	Image Type	(0008,0008)	2	DERIVED / PRIMARY
	Lossy Image Compression	(0028,2110)	1C	= 01 if JPEG lossy compressed

Module	Attribute	Tag	Type	Notes
	Transducer Data	(0018,5010)	3	Probe name (e.g. C5-2)
SOP Common	SOP Class UID	(0008,0016)	1	1.2.840.10008.5.1.4.1.1.3.1
	SOP Instance UID	(0008,0018)	1	created
	Specific Character Set	(0008,0005)	1C	From MWL or set to ISO_IR 100
	Instance Creation Date	(0008,0012)	3	created
	Instance Creation Time	(0008,0013)	3	created
Cine	Frame Time	(0018,1063)	1C	created
Multi-Frame	Number of Frames	(0028,0008)	1	created
Frame Pointers	Representative Frame Number	(0028,6010)	3	Frame number used as pictorial representation of the 3D Volume.
<b>Standard Extended SOP Class - Standard and Private Attributes</b>				
Patient Demographic	Patient's Address	(0010,1040)	3	from MWL
	Military Rank	(0010,1080)	3	from MWL
Patient Medical	Medical Alerts	(0010,2000)	3	from MWL
	Contrast Allergies	(0010,2110)	3	from MWL
	Smoking Status	(0010,21A0)	3	from MWL
	Pregnancy Status	(0010,21C0)	3	from MWL
	Last Menstrual Date	(0010,21D0)	3	from MWL or input by user
	Special Needs	(0038,0050)	3	from MWL
	Patient State	(0038,0500)	3	from MWL
Study Scheduling	Requesting Physician	(0032,1032)	3	from MWL
	Requesting Service	(0032,1033)	3	from MWL
	Requested Procedure Description	(0032,1060)	3	from MWL
	Requested Procedure Code Sequence	(0032,1064)	3	from MWL
	>Include 'Code Sequence Macro'		3	
Study Classification	Study Comments	(0032,4000)	3	input by user
Antares Private Attributes	Private Creator	(0039,0010)	1	SIEMENS MED SMS USG ANTARES 3D VOLUME
	Release Version	(0039,1000)	3	3.0.3
	VolumeAcquisitionDuration	(0039,1003)	3	
	VolumeRawDataType	(0039,1004)	3	Data Type (Cartesian/Scan-Converted/PreScanConverted Format)
	ScanType	(0039,1005)	3	
	ZlateralMin	(0039,1006)	3	Minimum span along the depth (wobble min.)
	ZlateralSpan	(0039,1007)	3	Span along the depth (wobble span)
	ZRadiusOfCurvature	(0039,1008)	3	Radius of curvature, in (wobble)
	WobbleCorrection	(0039,1009)	3	Wobbling shear correction factor (0.0 to 1.0)

Module	Attribute	Tag	Type	Notes
	ScaleAlongWidth	(0039,1010)	3	Width scaling mm/pixel
	ScaleAlongHeight	(0039,1011)	3	Height scaling mm/pixel
	ScaleAlongDepth	(0039,1012)	3	Depth scaling mm/pixel
	BufferSize	(0039,1013)	3	
	AcquisitionRate	(0039,1014)	3	Time required to acquire one volume
	DepthMinCm	(0039,1015)	3	The min/start depth for the BImage
	IsLeftRightFlippedEn	(0039,1016)	3	Whether the acquired images were Left/Right flipped
	IsUpDownFlippedEn	(0039,1017)	3	Whether the acquired images were up/down flipped
	IsVolumeGeomAccurate	(0039,1018)	3	Is the volume passed is geometrically accurate (In order to display ruler)
	BByteMaskOffset	(0039,1019)	3	Bytemasks is the offset fro Mask data which is used for space leaping optimization in renderer
	BByteMaskSize	(0039,1020)	3	Size of the byte mask data
	DepthMaxCm	(0039,1021)	3	The max/end depth for the BImage
	AcqPlaneRotationDeg	(0039,1022)	3	Angle by which the volume is to be rotated around, normal to the Aquisition plane (Z axis) (in degrees)
	BeamAxialSpan	(0039,1023)	3	beam span, in mm
	BeamLateralMin	(0039,1024)	3	Min lateral angle
	BeamLateralSpan	(0039,1025)	3	Angular span
	BeamAxialMin	(0039,1026)	3	Axial min or radius of curvature in 2d
	NumDisplaySamples	(0039,1027)	3	Number of actual samples along each beam
	DVolumeWidth	(0039,1028)	3	Volume Width of the Power/Doppler Volume
	DVolumeDepth	(0039,1029)	3	Volume Depth of the Power/Doppler Volume
	DVolumeHeight	(0039,1030)	3	Volume Height of the Power/Doppler Volume
	DVolumePosX	(0039,1031)	3	
	DVolumePosY	(0039,1032)	3	
	DVolumePosZ	(0039,1033)	3	
	DBeamAxialMin	(0039,1034)	3	Axial min or radius of curvature in 2d for Power/Doppler
	DBeamAxialSpan	(0039,1035)	3	

Module	Attribute	Tag	Type	Notes
	DBeamLateralMin	(0039,1036)	3	Min lateral angle for Power/Doppler
	DBeamLateralSpan	(0039,1037)	3	Angular span from Power/Doppler
	NumOfVolumesInSequence	(0039,1038)	3	Number Of Volumes In Sequence
	DByteMaskOffset	(0039,1039)	3	Bytemasks is the offset for the mask data which is used for space leaping optimization in renderer when in Power/Doppler
	DByteMaskSize	(0039,1040)	3	Size of the byte mask data when in Power/Doppler
<b>Antares Private Attributes - 3D Bookmark Data</b>				
Antares Private Attributes	PrivateCreatorVersionOfBookmark	(0039,1050)	3	3.6.0
	BCutPlaneEnable	(0039,1051)	3	Cut-plane volume rendering for B data
	BMprColorMapIndex	(0039,1052)	3	Index of the tint colormap for MPR B data
	BMprDynamicRangeDb	(0039,1053)	3	dB value of dynamic range curve for MPR B data
	BMprGrayMapIndex	(0039,1054)	3	Index of the image enhancement LUT for the MPR B data
	BVolumeRenderMode	(0039,1055)	3	Volume rendering mode for B data
	BVrBrightness	(0039,1056)	3	Brightness value for the volume rendered B data
	BVrContrast	(0039,1057)	3	Contrast value for the volume rendered B data
	BVrColorMapIndex	(0039,1058)	3	Index of the tint colormap for the volume rendered B data
	BVrDynamicRangeDb	(0039,1059)	3	dB value of dynamic range curve for the volume rendered B data
	BVrGrayMapIndex	(0039,105a)	3	Index of the image enhancement LUT for the volume rendered B data
	BVrOpacity	(0039,105b)	3	Opacity percentage of the opacity curve used for the volume rendered B data
	BVrThresholdHigh	(0039,105c)	3	High threshold of the opacity curve used for the volume rendered B data
BVrThresholdLow	(0039,105d)	3	Low threshold of the opacity curve used for the volume rendered B data	

Module	Attribute	Tag	Type	Notes
	BPreProcessFilterMix	(0039,105e)	3	Mix percentage used for mixing filtered data for the volume rendered B data
	CCutPlaneEnable	(0039,105f)	3	Cut-plane volume rendering for B data
	CFrontClipMode	(0039,1060)	3	Flag indicating whether Niche and Parallel Cut edit operation will clip power data.
	CMprColorMapIndex	(0039,1061)	3	Index of the tint colormap for MPR power data
	CMprColorFlowPriorityIndex	(0039,1062)	3	Threshold representing amount of power data cut from the MPR power data
	CVolumeRenderMode	(0039,1063)	3	Volume rendering mode for power data
	CVrColorMapIndex	(0039,1064)	3	Index of the tint colormap for the volume rendered power data
	CVrColorFlowPriorityIndex	(0039,1065)	3	Threshold representing amount of power data cut from the volume rendered power data
	CVrOpacity	(0039,1066)	3	Opacity percentage of the opacity curve used for the volume rendered power data
	CVrThresholdHigh	(0039,1067)	3	High threshold of the opacity curve used for the volume rendered power data
	CVrThresholdLow	(0039,1068)	3	Low threshold of the opacity curve used for the volume rendered power data
	VoiMode	(0039,1069)	3	Flag indicating whether VOI is on or off
	VoiRotationOffsetDeg	(0039,106a)	3	Fixed rotation applied to VOI
	VoiSizeRatioX	(0039,106b)	3	Width of VOI in relative units
	VoiSizeRatioY	(0039,106c)	3	Length of VOI in relative units
	VoiSizeRatioZ	(0039,106d)	3	Height of VOI in relative units
	VoiSyncPlane	(0039,106e)	3	Plane synced to the VOI
	VoiViewMode	(0039,106f)	3	Type indicating whether the rendering is synced to the front or back of the VOI
	VrOrientationA	(0039,1070)	3	Matrix representing the orientation of the volume rendered image
	MprOrientationA	(0039,1071)	3	Matrix representing the orientation of the MPRs
	VrOffsetVector	(0039,1072)	3	Vector representing the vertical and horizontal offset of the volume on the display

Module	Attribute	Tag	Type	Notes
	BlendingRatio	(0039,1073)	3	Value indicating the amount of blending between B and power data when blend is on
	FusionBlendMode	(0039,1074)	3	Mode for fusing in one display power and B volume rendered data
	QualityFactor	(0039,1075)	3	Factor determining the volume rendering quality
	RendererType	(0039,1076)	3	Type of the rendererer engine used
	SliceMode	(0039,1077)	3	Mode for displaying the textured map MPRs in the 3D quadrant
	ActiveQuad	(0039,1078)	3	Value indicating which quadrant in the display is active
	ScreenMode	(0039,1079)	3	Value indicating which screen layout is applied
	CutPlaneSide	(0039,107a)	3	Value indicating which half space of the cut-plane is used for volume rendering
	WireframeMode	(0039,107b)	3	Flag indicating whether wireframe around rendered data is on or off
	CrossmarkMode	(0039,107c)	3	Flag indicating whether crossmark is shown on the display
	MprDisplayType	(0039,107d)	3	Value indicating whether B or power or B+power data are displayed in the MPRs
	VolumeDisplayType	(0039,107e)	3	Value indicating whether B or power or B+power data are displayed in the volume rendered image
	LastReset	(0039,107f)	3	Value indicating the last reset
	LastNonFullScreenMode	(0039,1080)	3	Value indicating the last active quadrant before entering full screen
	MprToolIndex	(0039,1081)	3	Index indicating which tool (rotation, pan, resizing) is used on the MPRs
	VoiToolIndex	(0039,1082)	3	Index indicating which tool (rotation, pan, resizing) is used on the volume rendered image when VOI is on
	ToolLoopMode	(0039,1083)	3	Value indicating in which loop
	VolumeArbMode	(0039,1084)	3	Index indicating whether volume or MPR rotation is active on the 3D display window

Module	Attribute	Tag	Type	Notes
	MprZoomEn	(0039,1085)	3	Flag indicating whether zoom is enabled in the MPR
	IsVolumeZoomEn	(0039,1086)	3	Flag indicating whether zoom is enabled in the rendered volume
	ZoomLevelMpr	(0039,1087)	3	Value indicating the amount of zoom (in relative units) applied in the MPR
	ZoomLevelVolume	(0039,1088)	3	Value indicating the amount of zoom (in relative units) applied in the rendered volume
	IsAutoRotateEn	(0039,1089)	3	Flag indicating whether animation is enabled
	AutoRotateAxis	(0039,108a)	3	Value indicating the axis of rotation for the animation
	AutoRotateRangeIndex	(0039,108b)	3	Value indicating the total angle range for the animation
	AutoRotateSpeedIndex	(0039,108c)	3	Value indicating the speed (in relative units) for the animation
	CVrBrightness	(0039,108d)	3	Brightness value for the volume rendered power data
	CFlowStateIndex	(0039,108e)	3	Index for flow state of power data (low, medium, high)
	BSubmodeIndex	(0039,108f)	3	Index for indicating the B submode (THI, B, etc...)
	CSubmodeIndex	(0039,1090)	3	Index for indicating the C submode
	DICOMAttrNameCutPlane	(0039,1091)	3	Quadrant used to cut volume when volume cut enabled
	BookmarkChunkId	(0039,1092)	3	Index of Bookmark
	SequenceMinChunkId	(0039,1093)	3	Begin range index of volume sequence
	SequenceMaxChunkId	(0039,1094)	3	End range index of volume sequence
	VolumeRateHz	(0039,1095)	3	Rate at which volumes are rendered
	VoiPositionOffsetX	(0039,109a)	3	Offset in the x dimension between the center of the VOI and center of volume in relative units
	VoiPositionOffsetY	(0039,109b)	3	Offset in the y dimension between the center of the VOI and center of volume in relative units
	VoiPositionOffsetZ	(0039,109c)	3	Offset in the z dimension between the center of the VOI and center of volume in relative units

Module	Attribute	Tag	Type	Notes
	VrToolIndex	(0039,109d)	3	Index indicating which tool (rotation, pan, resizing) is used on the volume rendered image
	ShadingPercent	(0039,109e)	3	Value indicating the amount of shading in the volume rendered image
	VolumeType	(0039,109f)	3	Value indicating the type of volume (B or B and Power)
	VolumeRateHz	(0039,1095)	3	Rate at which volumes are rendered
	DICOMAttrNameVrQuadDisplayType	(0039,10a0)	3	The type of display to show in the volume quadrant
	DICOMAttrNameMprCenterLocation	(0039,10a1)	3	Offset location of slice centerpoint with respect to quadrant center
	DICOMAttrNameSliceMode	(0039,1077)	3	Value indicating that system in multislice mode
	DICOMAttrNameSliceRangeType	(0039,10e0)	3	Value indicating type of slice mode (horizontal/vertical)
	DICOMAttrNameSliceMPRPlane	(0039,10e1)	3	Value indicating selected MPR for slice mode (Acquisition/Elevation/Coronal)
	DICOMAttrNameSliceLayout	(0039,10e2)	3	Selected layout for slice mode (2x2, 3x3, 4x4, 6x6)
	DICOMAttrNameSliceSpacing	(0039,10e3)	3	Value indicates the spacing between MPR slices
	DICOMAttrNameThinVrMode	(0039,10e4)	3	Value indicating that system in ThinVr mode
	DICOMAttrNameThinVrThickness	(0039,10e5)	3	Selected thickness value
	DICOMAttrNameVoiPivotX	(0039,10e6)	3	Curved TOP VOI pivot x
	DICOMAttrNameVoiPivotY	(0039,10e7)	3	Curved TOP VOI pivot y
	DICOMAttrNameVoiPivotZ	(0039,10e8)	3	Curved TOP VOI pivot z
	DICOMAttrNameCTopVoiQuad	(0039,10e9)	3	Curved TOP VOI Quad

**Table 13: Comprehensive SR Image IOD Modules**

Entity Name	Module Name	Reference
Patient	Patient	See Table 9
	Specimen Identification	Not Used
Study	General Study	See Table 9
	Patient Study	See Table 9
Series	SR Document Series	See Table 14
Equipment	General Equipment	See Table 9, except for Software Versions (0018,1020)
	Software Versions (0018,1020)	Set to "5.0"

Entity Name	Module Name	Reference
Document	SR Document General	See Table 15
	SR Document Content	See Table 16
	SOP Common	See Table 9, 10, 11

**Table 14: SR Document Series Module**

Attribute	Tag	Type	Notes
Modality	(0008,0060)	1	Defined term “SR” used
Series Instance UID	(0020,000E)	1	Uniquely generated by the Antares
Series Number	(0020,0011)	1	Internally generated; incremented for each new exam within a study
Reference Performed Procedure Step Sequence	(0008,1111)	2	
>Referenced SOP Class UID	(0008,1150)	1C	
>Reference SOP Instance UID	(0008,1155)	1C	

**Table 15: SR Document General Module**

Attribute	Tag	Type	Notes
Instance Number	(0020,0013)	1	Internally generated incremented for each new SR document within a study
Completion Flag	(0040,A491)	1	Defined Term “PARTIAL” used
Verification Flag	(0040,A493)	1	Defined Term “UNVERIFIED” used
Content Date	(0008,0023)	1	Date of creation
Content Time	(0008,0033)	1	Time of creation
Referenced Request Sequence	(0040,A370)	1C	Filled in if the exam is based on a Worklist entry
>Study Instance UID	(0020,000D)	1	Taken from the Study Instance UID in the General Study Module
>Accession Number	(0008,0050)	2	From Worklist or Patient Registration
>Requested Procedure ID	(0040,1001)	2	Taken from Worklist if available
>Requested Procedure Description	(0032,1060)	2	Taken from Worklist if available
Pertinent Other Evidence Sequence	(0040,A385)	1	
>Include ‘SOP Instance Reference Macro’			

**5.2.2.2 SR Document Content Module**

The SR Document Content Module is described in the following table and in the appendices.

**Table 16: SR Document Content Module Attributes**

Attribute	Tag	Type	Notes
Content Template Sequence	(0040,A504)	1C	Template ID
>Template Identification Macro			
Relationship Type	(0040,A010)	1	CONTAINS
Value Type	(0040,A040)	1	CONTAINER
Continuity of Content	(0040,A050)	1C	SEPARATE
Concept Name Code Sequence	(0040,A043)	1C	See Appendix for “OB Gyn Ultrasound Procedure Report”, “Vascular Ultrasound Procedure Report”, or “Adult Echocardiography Procedure Report”
> ‘Code Sequence Macro’			
Content Sequence	(0040,A730)	1C	See Appendix for “OB Gyn Ultrasound Procedure Report”, “Vascular Ultrasound Procedure Report”, or “Adult Echocardiography Procedure Report”
>Relationship Type	(0040,A010)	1	CONTAINS

**5.2.2.3 Content Template**

The Antares Ultrasound System supports the following root Templates for SR SOP Instances created, processed, or displayed by the Antares.

**Table 17: Root Templates for SR SOP Instances**

SOP Class	Template ID	Template Description	Use
Comprehensive SR	5000	“OB-GYN Ultrasound Procedure Report”	Create
Comprehensive SR	5100	“Vascular Ultrasound Report”	Create
Comprehensive SR	5200	“Adult Echocardiography Procedure Report”	Create

**5.2.2.3.1 Error Handling**

Table 18: indicates the possible response status codes, which a SCP may return following the SCU’s C-STORE-RSP command. Only those status responses that indicate some form of error condition are presented to the user.

A successful C-STORE operation will allow the AE to continue to the next action desired by the user.

**Table 18: C-STORE Status Responses**

Service Status	Futher Meaning	Protocol Codes	Related Fields
Refused	Out of resources.	A7xx	None
Error	Data set does not match SOP Class. Cannot understand.	A9xx Cxxx	None
Warning	Coercion of data Elements. Data set does not match SOP Class. Elements discarded.	B000 B007 B006	None
Success		0000	None

**5.3 Storage Commitment AE Specification**

The Antares Storage Commitment AE provides Standard Conformance to the following DICOM SOP Classes as an SCU.

**Table 19: Standard SOP Classes as Storage Commitment Push Model**

SOP Class Name	SOP Class UID
Storage Commitment Push Model	1.2.840.10008.1.20.1

**5.3.1 Association Establishment Policies**

**5.3.1.1 General**

The configuration of Antares Storage Commitment AE defines the Application Entity Titles, the port numbers, the host names and IP addresses.

**5.3.1.2 Number of Associations**

The Antares Storage Commitment AE initiates several associations at a time, one for each storage commitment request being processed.

**5.3.1.3 Asynchronous Nature**

The Antares Storage Commitment AE does not support asynchronous communication (multiple outstanding transactions over a single association).

**5.3.1.4 Implementation Identifying Information**

The Antares Storage Commitment AE provides a single Implementation Class UID of

- “1.3.12.2.1107.5.9.20000101”

and an Implementation Version Name of

- “SIEMENS\_SWFSYNGO”.

**5.3.2 Association Initiation by Real-World Activity**

The Antares Storage Commitment AE initiates an association when acting as SCU, in order to send a request for storage commitment.

**5.3.2.1 Real-World Activity - Send Storage Commitment Request**

**5.3.2.1.1 Associated Real-World Activity - Send Storage Commitment Request**

The user has sent (or archived) images to another DICOM node, which is configured as storage commitment SCP. The Antares will automatically attempt to send a storage commitment request for these images.

**5.3.2.1.2 Proposed Presentation Contexts - Send Storage Commitment Request**

The Antares Storage Commitment AE will propose Presentation Contexts as shown in the following table:

**Table 20: Initiation Presentation Context Storage Commitment Request**

Presentation Context Table					
Abstract Syntax		Transfer Syntax		Role	Extended Negotiation
Name	UID	Name List	UID List		
Storage Commitment Push Model SOP Class	1.2.840.10008.1.20.1	Implicit VR Little Endian	1.2.840.10008.1.2	SCU	None
		Explicit VR Big Endian	1.2.840.10008.1.2.2		
		Explicit VR Little Endian	1.2.840.10008.1.2.1		

**5.3.2.1.3 SOP Specific Conformance Statement - Send Storage Commitment Request**

The SCU sends the N-ACTION-RQ message and waits for the N-ACTION-RSP. After receiving this, the transaction is marked as “waiting”.

When configured to automatically transfer images “During the Exam”, a separate Storage Commitment Request is made for each image transferred to a Storage SCP that is configured for storage commitment.

Depending on a configuration value, the association will be closed or kept open. In the first case, there is another configurable value giving the number of minutes (by default 60) to wait for the corresponding N-EVENT-REPORT-RQ. In the second case, this time is the (also configurable) time-out for the association. For both cases, if the N\_EVENT\_REPORT-RQ does not arrive during the configured time, the transaction will be marked as failed.

Storage Commitment is supported for all the Storage SOP class UIDs as listed in Table 6: on page 18. The Referenced Study Component Sequence is not supported.

Storage Media File-Set ID and UID Attributes will not be supported in the N-ACTION primitive invoked by the Storage Commitment SCU.

**5.3.3 Association Acceptance Policy**

The Antares Storage Commitment AE accepts an association when acting as SCU if configured to receive N-EVENT-REPORT on a separate association. *Note: The Antares may be configured to accept results in the same or separate association as the Storage Commitment Request.*

**5.3.3.1 Real World Activity - Receive Storage Commitment Response**

**5.3.3.1.1 Associated Real World Activity - Receive Storage Commitment Response**

When configured to receive results on a separate association, the Antares Storage Commitment AE sends a Storage Commitment Request and then closes the association. The Antares Storage Commitment AE will then accept an association request from the Storage Commitment SCP that wants to send Storage Commitment results.

**5.3.3.1.2 Accepted Presentation Contexts - Receive Storage Commitment Response**

The Antares Storage Commitment AE will accept Presentation Contexts as shown in the following table:

**Table 21: Presentation Context accepted for Storage Commitment**

Presentation Context Table					
Abstract Syntax		Transfer Syntax		Role	Extended Negotiation
Name	UID	Name List	UID List		
Storage Commitment Push Model SOP Class	1.2.840.10008.1.20.1	Implicit VR Little Endian	1.2.840.10008.1.2	SCU	None
		Explicit VR Big Endian	1.2.840.10008.1.2.2		
		Explicit VR Little Endian	1.2.840.10008.1.2.1		

**5.3.3.1.3 SOP Specific Conformance Statement - Receive Storage Commitment Response**

If the N\_EVENT\_REPORT received has the status of “Complete - Failure Exists”, the transaction is marked as failed, otherwise the transaction is marked as “completed”. In both cases, a message is shown to the user. The committed images are marked in the local database.

The Antares automatically re-sends images and Storage Commitment Requests for failed storage commitment results with the following failure codes:

- 0112H - No such object instance.
- 0131H - Duplicate transaction UID.

The Antares does not re-send images from a failed storage commitment result with the following failure codes:

- 0110H - Processing failure
- 0213H - Resource limitation
- 0122H - Referenced SOP Class not supported
- 0119H - Class / Instance conflict

The storage commitment status is displayed at the image level in the Patient Browser. Statuses are:

- S?/A? = Send/Archive Storage Commitment Waiting for result.
- Sf/Af = Send/Archive Storage Commitment Failed.
- SC/AC = Send/Archive Storage Commitment Succeeded.

When all images in a series are successfully committed, a corresponding “S” or “A” is displayed at the series level of the Patient Browser.

When all series in a study are successfully committed, a corresponding “S” or “A” is displayed at the study level of the Patient Browser.

**5.4 Print AE Specification**

The print management SCU invokes print management DIMSE services to transfer images from the local AE to the remote SCP AE to print the images with the defined film format and size on a selected network DICOM hardcopy printer. See DICOM part 4 annex H.

The Antares system provides Standard Conformance to the following DICOM V3.0 Basic Grayscale Print Management Meta SOP Class, Basic Color Print Management Meta SOP Class and the optional Print Job SOP Class as an SCU.

**Table 22: Basic Gray Scale Print Management Meta SOP Classes**

SOP Class Name	SOP Class UID	Usage
Basic Grayscale Print Management Meta SOP Class	1.2.840.10008.5.1.1.9	Standard
Basic Film Session SOP Class	1.2.840.10008.5.1.1.1	Standard
Basic Film Box SOP Class	1.2.840.10008.5.1.1.2	Standard
Basic Grayscale Image Box SOP Class	1.2.840.10008.5.1.1.4	Standard
Printer SOP Class	1.2.840.10008.5.1.1.16	Standard
Print Job SOP Class	1.2.840.10008.5.1.1.14	Standard

**Table 23: Basic Color Print Management Meta SOP Classes**

SOP Class Name	SOP Class UID	Usage
Basic Color Print Management Meta SOP Class	1.2.840.10008.5.1.1.18	Standard
Basic Film Session SOP Class	1.2.840.10008.5.1.1.1	Standard
Basic Film Box SOP Class	1.2.840.10008.5.1.1.2	Standard
Basic Color Image Box SOP Class	1.2.840.10008.5.1.1.4.1	Standard
Printer SOP Class	1.2.840.10008.5.1.1.16	Standard
Print Job SOP Class	1.2.840.10008.5.1.1.14	Standard

All mandatory elements of these classes are supported.

**5.4.1 Association Establishment Policies**

**5.4.1.1 General**

The configuration of the Antares DICOM print management application defines the Application Entity Titles, the port numbers, the host names and IP addresses.

#### **5.4.1.2 Number of Associations**

The Antares DICOM application initiates one/several association(s) at a time, one for each transfer request being processed.

#### **5.4.1.3 Asynchronous Nature**

The Antares DICOM software does not support asynchronous communication (multiple outstanding transactions over a single association).

#### **5.4.1.4 Implementation Identifying Information**

The Antares DICOM software provides a single Implementation Class UID of

- “1.3.12.2.1107.5.9.20000101”

and an Implementation Version Name of

- “SIEMENS\_SWFSYNGO”.

### **5.4.2 Association Initiation by Real-World Activity**

The Print Management SCU and SCP establish an association by using the DICOM association services. During association establishment the Print Management application entities negotiate the supported SOP classes to exchange the capabilities of the SCU and the SCP. If the SCU supports only mandatory SOP classes, the negotiation of optional capabilities is not necessary.

#### **5.4.2.1 Real World Activity - Print**

The system has three possible print configurations in the “Print/Store” preset page.

When “during exam” is selected, an association is opened with the destination printer after the last image on the film sheet is acquired and is closed at the end of film sheet transfer.

If transfer at “end of exam” has been configured, an association is opened with the destination printer(s) when the exam is completed (I.e. a new Patient / Study is registered or End Exam is performed). All film sheets are then transferred. An association is opened for each of the film sheets transferred.

When auto transfer is “disabled” the system copies images onto the film sheet, but auto transfer does not occur.

Printing of Multi-frame Images is not supported.

##### **5.4.2.1.1 Associated Real World Activities - Print**

An association is established when the user initiates an “Expose Film Job” operation from the Filming UI screen. Individual images or entire exams can be transferred to the selected DICOM Print device. The association is opened when the first sheet of each selected exam is transferred and closed when the last sheet transfer is completed.

**5.4.2.1.2 Proposed Presentation Contexts**

**Table 24: Presentation Context Table**

Presentation Context Table					
Abstract Syntax		Transfer Syntax		Role	Extended Negotiation
Name	UID	Name List	UID List		
Basic Grayscale Print Management Meta SOP Class	1.2.840.10008.5.1.1.9	Explicit VR Little Endian Explicit VR Big Endian Implicit VR Little Endian	1.2.840.10008.1.2.1 1.2.840.10008.1.2.2 1.2.840.10008.1.2	SCU	None
Basic Color Print Management Meta SOP Class	1.2.840.10008.5.1.1.18	Explicit VR Little Endian Explicit VR Big Endian Implicit VR Little Endian	1.2.840.10008.1.2.1 1.2.840.10008.1.2.2 1.2.840.10008.1.2	SCU	None
Basic Film Session SOP Class	1.2.840.10008.5.1.1	Explicit VR Little Endian Explicit VR Big Endian Implicit VR Little Endian	1.2.840.10008.1.2.1 1.2.840.10008.1.2.2 1.2.840.10008.1.2	SCU	None
Basic Film Box SOP Class	1.2.840.10008.5.1.2	Explicit VR Little Endian Explicit VR Big Endian Implicit VR Little Endian	1.2.840.10008.1.2.1 1.2.840.10008.1.2.2 1.2.840.10008.1.2	SCU	None
Basic Color Image Box SOP Class	1.2.840.10008.5.1.1.4.1	Explicit VR Little Endian Explicit VR Big Endian Implicit VR Little Endian	1.2.840.10008.1.2.1 1.2.840.10008.1.2.2 1.2.840.10008.1.2	SCU	None
Printer SOP Class	1.2.840.10008.5.1.1.16	Explicit VR Little Endian Explicit VR Big Endian Implicit VR Little Endian	1.2.840.10008.1.2.1 1.2.840.10008.1.2.2 1.2.840.10008.1.2	SCU	None
Print Job SOP Class	1.2.840.10008.5.1.1.14	Explicit VR Little Endian Explicit VR Big Endian Implicit VR Little Endian	1.2.840.10008.1.2.1 1.2.840.10008.1.2.2 1.2.840.10008.1.2	SCU	None

**5.4.2.1.2.1 SOP Specific Conformance Statement**

The Print AE provides standard conformance to the Basic Grayscale Print Management Meta SOP Class and Basic Color Print Management Meta SOP Class as an SCU.

The application uses a setting platform to define the properties of the connected DICOM SCP. For example,

- Maximum number of print jobs in the queue.
- Maximum number of print copies.
- Supported film sizes of the connected DICOM SCP.
- Supported film formats of the DICOM SCP.
- Lookup table definition.

**5.4.2.1.2.1.1 SOP Specific Conformance to Basic Film Session SOP Class**

The Basic Film Session information object definition describes all the user-defined parameters, which are common for all the films of a film session. The Basic Film Session refers to one or more Basic Film Boxes that are printed on one hardcopy printer.

The Antares DICOM Print application supports the following DIMSE Service Elements for the Basic Film session SOP Class as SCU:

- N-CREATE
- N-DELETE

The Basic Film Session SOP Class SOP Class N\_CREATE\_RQ (SCU) uses the following attributes described in Table 25: .

**Table 25: Basic Film Session N\_CREATE\_RQ attributes**

Attribute Name	Attribute Tag	Usage	Range	Description
Number of Copies	(2000, 0010)	U	1 to 99	Number of requested film copies.
Medium Type	(2000, 0030)	U	PAPER CLEAR FILM BLUE FILM	Media used for hardcopy; may be further limited by print vendor/server
Film Destination	(2000, 0040)	U	MAGAZINE PROCESSOR	May be further limited by print vendor, and/or print server

The affected SOP Instance UID received in the N\_CREATE\_RSP message from the SCP will be saved internally and used for later requests like N\_DELETE\_RQ on the Basic Film Session SOP Class.

**Table 26: Attributes of the N\_DELETE\_RQ - Basic Film Session SOP Class**

Attribute Name	Attribute Tag	Source of Information
Requested SOP Instance UID	(0008,0018)	Affected SOP Instance UID of N_CREATE_RSP on Basic Film Session.

The N\_DELETE\_RQ on the Basic Film Session SOP Class is used to delete the complete Basic Film Session SOP Instance hierarchy.

The Basic Film Session SOP Class interprets the status codes in Table 27: from (NCREATE\_RSP, N\_DELETE\_RSP messages).

**Table 27: Basic Film Session SOP Status**

Service Status	Meaning	Protocol Code
Failure	Film Session SOP Instances hierarchy does not contain film box SOP instances	C600
	Unable to create print job, print queue is full	C601
	Image size is larger than images box size	C603
Warning	Memory allocation not supported	B600
	Film session printing is not supported	B601
	Film box does not contain image box (empty page)	B602
Success	Film belonging to the film session are accepted for printing	0000

**5.4.2.1.2.1.2 SOP Specific Conformance to Basic Film Box SOP Class**

The Basic Film Box Information object definition describes all the user-defined parameters of one film of the film session. The Basic Film Box information description defines the presentation parameters, which are common for all images on a given sheet of film. The Basic Film Box refers to one or more Image Boxes.

Supported as SCU are:

**Table 28: Supported DIMSE Services for Basic Film Box SOP Class**

Name	Usage	Description
N-Create	M	Creates the Film Box.
N-Delete	U	Deletes the Film Box. Issued after each film is printed.
N-Action	M	PRINT. Sent after each Film Box is filled, and at the end of the exam to force a print of partially filled Film Box.

The Basic Film Box SOP Class N\_CREATE\_RQ message uses the attributes in Table 29: . The used values for each attribute depend on how the DICOM printer is configured within the ACUSON Antares product.

**Table 29: Used Basic Film Box N\_CREATE\_RQ Attributes**

Attribute Name	Attribute Tag	Usage	Range	Description
Image Display Format	(2010,0010)	M	STANDARD\C,R (with C number of columns and R number of rows)	Set to STANDARD\1,1 if “formatted by printer is selected” Otherwise dependent on configured printer
Film Orientation	(2010,0040)	M	PORTRAIT	Always set to PORTRAIT
Film Size ID	(2010,0050)	M	8INX10IN 10INX12IN 10INX14IN 11INX14IN 14INX14IN 14INX17IN 24CMX24CM 24CMX30CM	Valid film sheet sizes
Magnification Type	(2010,0060)	M	REPLICATE BILINEAR CUBIC NONE	Used.
Min. Density	(2010,0120)	U	0-999	Used - printer specific
Max Density	(2010,0130)	U	0-999	Used - printer specific
Referenced Film Session Sequence	(2010,0500)	M	1.2.840.10008.5.1.1.1	

Attribute Name	Attribute Tag	Usage	Range	Description
Referenced SOP Class UID	(0008,1150)	M		
Referenced SOP Instance UID	(0008,1155)	M		

The N\_CREATE\_RSP message from the SCP then contains the References Image Box Sequence with its SOP Class and Instance UID's, which is stored internally and then used for the Basic Image Box SOP Class N-SET RQ messages.

After all parameters for the Image boxes on the film sheet have been sent then the Antares DICOM Print application SCU will issue a N\_ACTION\_RQ message with the SOP Instance UID of the Basic Film Box (returned in the N\_CREATE\_RSP of the Basic Film Box SOP Class) and the Action Type ID set to 1.

The affected SOP Instance UID received in N\_CREATE\_RSP message from the SCP will be saved internally and can be used later for the N\_DELETE\_RQ request on the Basic Film Box SOP Class (see Table 30: ).

**Table 30: Attributes of the N\_DELETE\_RQ on the Basic Film Session SOP Class**

Attribute Name	Tag	Source of Information
Requested SOP Instance UID	(0008,0018)	Affected SOP Instance UID of N_CREATE_RSP on Basic Film Box

The Basic Film Box SOP class interprets the status codes Table 31: from the N\_CREATE\_RSP, N\_DELETE\_RSP and N\_ACTION\_RSP messages.

**Table 31: Basic Film Box SOP Status**

Service Status	Meaning	Protocol Codes
Failure	Unable to create print job; print queue is full	C602
	Image size is larger than image box size	C603
Warning	Film box does not contain image box (empty page)	B603
	Requested MinDensity or MaxDensity outside of printer's operating range	B605
Success	Film accepted for printing	0000

**5.4.2.1.2.1.3 SOP Specific Conformance to Basic Grayscale Image Box SOP Class**

The Basic Grayscale Image Box information object definition is the presentation of an image and image related data in the image area of a film. The Basic Image Box information describes the parameters and image pixel data, which apply to a single image of a sheet of film.

The printing is only suspended in the case of a failure return status of the SCP

The Grayscale Image Box SOP Class uses only the N\_SET\_RQ with the attributes in Table 32: .

**Table 32: Used Basic Grayscale Image Box N-Set Attributes**

Name	Attribute	Usage SCU	Supported Values
Image Position	(2020,0010)	M	1, if “formatted by printer” is selected, otherwise position for each image
Basic Grayscale Image Sequence	(2020,0110)	M	
>Samples Per Pixel	(0028,0002)	M	1
>Photometric Interpretation	(0028,0004)	M	MONOCHROME2 for Grayscale images
>Rows	(0028,0010)	M	
>Columns	(0028,0011)	M	
>Pixel Aspect Ratio	(0028,0034)	M	
>Bits Allocated	(0028,0100)	M	8
>Bits Stored	(0028,0101)	M	8
>High Bit	(0028,0102)	M	7
>Pixel Representation	(0028,0103)	M	0
>Pixel Data	(7FE0,0010)	M	

The Grayscale Image Box SOP Class interprets the following status codes:

**Table 33: Basic Grayscale Image Box SOP Status**

Service Status	Meaning	Protocol Codes
Failure	Image contains more pixels than printer can print in Image Box	C603
	Insufficient memory in printer to store the image	C605
Success		0000

**5.4.2.1.2.1.4 SOP Specific Conformance to Basic Color Image Box SOP Class**

The Basic Color Image Box information object definition is the presentation of an image and image related data in the image area of a film. The Basic Image Box information describes the presentation parameters and image pixel data, which apply to a single image of a sheet of film.

The Color Image Box SOP Class uses only the N\_SET\_RQ with the attributes in Table 34: .

**Table 34: Used Basic Color Image Box N-Set Attributes**

Name	Attribute	Usage SCU	Supported Values
Image Position	(2020,0010)	M	1
Basic Color Image Sequence	(2020,0111)	M	
>Samples Per Pixel	(0028,0002)	M	3
>Photometric Interpretation	(0028,0004)	M	RGB
>Planar Configuration	(0028,0006)	M	0
>Rows	(0028,0010)	M	
>Columns	(0028,0011)	M	
>Pixel Aspect Ratio	(0028,0034)	M	

Name	Attribute	Usage SCU	Supported Values
>Bits Allocated	(0028,0100)	M	8
>Bits Stored	(0028,0101)	M	8
>High Bit	(0028,0102)	M	7
>Pixel Representation	(0028,0103)	M	0
>Pixel Data	(7FE0,0010)	M	

The Color Image Box SOP Class interprets the status codes in Table 35: .

**Table 35: Basic Color Image Box SOP Status**

Service Status	Meaning	Protocol Codes
Warning	Image size larger than image box size	B604
Failure	Image contains more pixels than printer can print in Image Box	C603
	Insufficient memory in printer to store the image	C605
Success		0000

**5.4.2.1.2.1.5 SOP Specific Conformance to Printer SOP Class**

The Printer SOP Class has the possibility to monitor the status of the hardcopy printer in a synchronous and asynchronous way.

The Antares DICOM Print application uses the mandatory N-EVENT Report DIMSE service to monitor the changes of the printer status in an asynchronous way.

It can directly ask the Print SCP for it’s status or can receive Events from the Print SCP asynchronously:

- N-GET as SCU
- N-EVENT-REPORT as SCU

In both cases the following information is supported:

**Table 36: Used Printer N-Event Reports**

Event type name	Event	Attributes	Tag	Usage SCU
Normal	1	0000		
Warning	2	Printer status info	(2110,0020)	U
Failure	3	Printer status info	(2110,0020)	U

**Table 37: Mandatory Printer N\_GET\_RSP, N\_EVENT\_REPORT\_RQ Attributes**

Attribute Name	Tag	Usage SCP	Supported Values
Printer Status	(2110,0010)	M	NORMAL FAILURE WARNING
Printer Status Info	(2110,0020)	M	SUPPLY EMPTY SUPPLY LOW RECEIVER FULL NO RECEIVE MGZ FILM JAM

**5.4.2.1.2.1.6 SOP Specific Conformance to Print Job SOP Class**

The Print Job SOP Class has the possibility to monitor the execution of the print process. The Antares DICOM Print application supports the optional N-EVENT-REPORT DIMSE service to receive the changes of the print job status in an asynchronous way.

The following information is supported:

**Table 38: Used Print Job N-Event Reports**

Event Type Name	Event	Attributes	Tag	Usage SCU
Normal	1	Execution Status Info	(2100,0030)	U
		Print Job ID	(2100,0010)	Print Queue Management SOP Class not supported
		Film Session Label	(2000,0050)	U
		Printer Name	(2110,0030)	U
Printing	2	Exception Status Info	(2100,0030)	U
		Print Job ID	(2110,0020)	Print Queue Management SOP Class not supported
		Film Session Label	(2000,0050)	U
		Printer Name	(2110,0030)	U
Done	3	Exception Status Info	(2100,0030)	U
		Print Job ID	(2100,0010)	Print Queue Management SOP Class not supported
		Film Session Label	(2000,0050)	U
		Printer Name	(2110,0030)	U
Failure	4	Exception Status Info	(2100,0030)	U
		Print Job ID	(2100,0010)	Print Queue Management SOP Class not supported
		Film Session Label	(2000,0050)	U
		Printer Name	(2110,0030)	U

**5.5 Modality Worklist AE Specification**

The Modality Worklist SCU requests that the remote SCP performs a match of all keys specified in the query against the information in its worklist database. The Antares system provides Standard Conformance to the following DICOM V3.0 SOP Class as an SCU:

**Table 39: SOP Classes as an SCU**

SOP Class Name	SOP Class UID
Modality Worklist Information Model - FIND	1.2.840.10008.5.1.4.31

**5.5.1 Association Establishment Policies**

**5.5.1.1 General**

The configuration of the Antares DICOM modality worklist application defines the Application Entity Title, the port number, the host name and IP address.

**5.5.1.2 Number of Associations**

The Antares DICOM application initiates one worklist association at a time, one for each transfer request being processed.

**5.5.1.3 Asynchronous Nature**

The Antares DICOM software does not support asynchronous communication (multiple outstanding transactions over a single association).

**5.5.1.4 Implementation Identifying Information**

The Antares DICOM software provides a single Implementation Class UID of

- “1.3.12.2.1107.5.9.20000101”

and an Implementation Version Name of

- “SIEMENS\_SWFSYNGO”.

**5.5.2 Association Initiation by Real-World Activity**

The Modality Worklist SCU establishes an association by using the DICOM association services.

The following DIMSE-C operation is supported as SCU: C-FIND.

**5.5.2.1 Real World Activity—Worklist**

A separate Network association is established by the AE for each Worklist query operation, with only one active query at a time. The association is closed at completion of the query.

**5.5.2.1.1 Proposed Presentation Context**

**Table 40: Worklist Presentation Context Table**

Presentation Context Table					
Abstract Syntax		Transfer Syntax		Role	Extended Negotiation
Name	UID	Name List	UID List		
Modality Worklist Information Model – FIND	1.2.840.10008.5.1.4.31	Implicit VR Little Endian	1.2.840.10008.1.2	SCU	None
		Explicit VR Big Endian	1.2.840.10008.1.2.2		
		Explicit VR Little Endian	1.2.840.10008.1.2.1		

The Antares system will always act as an SCU and be the client in a client-server model.

**5.5.2.1.2 SOP Specific Conformance to Modality Worklist Service SOP Class**

The Antares Worklist AE provides conformance to the following DICOM Service SOP Classes as an SCU all at a standard extended level of conformance:

Table 41: provides the list of user configurable matching attributes requested in the Broad Query of the Modality Worklist (C-FIND).

**Table 41: Modality Worklist Matching Key Attributes (Broad Query)**

Module	Attribute Name	Tag	Match Type	Query Value
Scheduled Procedure Step	Scheduled Procedure Step Sequence	(0040,0100)	R	
	>Scheduled Station AE Title	(0040,0001)	R	Antares HIS/RIS SCU AE Title or “*”
	>Scheduled Procedure Step Start Date	(0040,0002)	R	Today’s date or user specified date range
	>Scheduled Procedure Step Start Time	(0040,0003)	O	Current time - 23:59:59 or User specified time range or zero length
	>Modality	(0008,0060)	R	“US” or “*”

Table 42: provides the list of user configurable matching attributes requested in the Patient based Query of the Modality Worklist (C-FIND).

**Table 42: Modality Worklist Matching Key Attributes (Patient Based Query)**

Module	Attribute Name	Tag	Match Type	Query Value
Requested Procedure Module	Requested Procedure ID	(0040,1001)	R	As entered in the “Patient Worklist Query” dialog
Image Service Request	Accession Number	(0008,0050)	R	As entered in the “Patient Worklist Query” dialog
Patient Identification	Patient’s Name	(0010,0010)	R	As entered in the “Patient Worklist Query” dialog
	Patient ID	(0010,0020)	R	As entered in the “Patient Worklist Query” dialog

**Return Key Attributes used from the Worklist C\_FIND\_RSP**

The Antares DICOM worklist SCU supports worklist queries with return key attributes of all types. The following table describes the return keys that the SCU supports. Most attributes can be shown in the User Interface; Patient Registration or Patient Browser. Attributes displayed in the Patient Browser are configurable.

Table 43: Modality Worklist C\_FIND\_RSP Return Key Attributes

Attribute Name	Tag	Return Key Type	Displayed in User Interface
<b>SOP Common</b>			
Specific Character Set	(0008,0005)	1C	
<b>Scheduled Procedure Step</b>			
Scheduled Procedure Step Sequence	(0040,0100)	1	
>Scheduled Station AE Title	(0040,0001)	1	yes
>Scheduled Procedure Step Start Date	(0040,0002)	1	yes
>Scheduled Procedure Step Start Time	(0040,0003)	1	yes
>Scheduled Procedure Step End Date	(0040,0004)	3	
>Scheduled Procedure Step End Time	(0040,0005)	3	
>Modality	(0008,0060)	1	yes
>Scheduled Performing Physician's Name	(0040,0006)	2	yes
>Scheduled Procedure Step Description	(0040,0007)	1C	yes
>Scheduled Station Name	(0040,0010)	2	yes
>Scheduled Procedure Step Location	(0040,0011)	2	yes
>Scheduled Protocol Code Sequence	(0040,0008)	1C	
>>Code Value	(0008,0100)	1C	yes
>>Coding Scheme Designator	(0008,0102)	1C	yes
>>Coding Scheme Version	(0008,0103)	3	yes
>>Code Meaning	(0008,0104)	3	yes
>Pre-Medication	(0040,0012)	2C	yes
>Scheduled Procedure Step ID	(0040,0009)	1	yes
>Requested Contrast Agent	(0032,1070)	2C	yes
>Scheduled Procedure Step Status	(0040,0020)	3	yes
>Comments on the Scheduled Procedure Step	(0040,0400)	3	
<b>Requested Procedure</b>			
Requested Procedure ID	(0040,1001)	1	yes
Requested Procedure Description	(0032,1060)	1C	yes
Requested Procedure Code Sequence	(0032,1064)	1C	
>Code Value	(0008,0100)	1C	yes
>Code Scheme Designator	(0008,0102)	1C	yes
>Code Scheme Version	(0008,0103)	3	yes
>Code Meaning	(0008,0104)	3	yes
Study Instance UID	(0020,000D)	1	
Referenced Study Sequence	(0008,1110)	2	
>Referenced SOP Class UID	(0008,1150)	1C	
>Referenced SOP Instance UID	(0008,1155)	1C	
Requested Procedure Priority	(0040,1003)	2	yes
Patient Transport Arrangements	(0040,1004)	2	
Reason for the Requested Procedure	(0040,1002)	3	
Confidentiality Code	(0040,1008)	3	

Attribute Name	Tag	Return Key Type	Displayed in User Interface
Reporting Priority	(0040,1009)	3	
Names of Intended Recipients of results	(0040,1010)	3	
Requested Procedure Comments	(0040,1400)	3	yes
Requested Procedure Location	(0040,1005)	3	
<b>Imaging Service Request</b>			
Accession Number	(0008,0050)	2	yes
Requesting Physician	(0032,1032)	2	yes
Referring Physician's Name	(0008,0090)	2	yes
Reason for the Imaging Service Request	(0040,2001)	3	
Imaging Service Request Comments	(0040,2400)	3	yes
Requesting Service	(0032,1033)	3	yes
Issuing Date of Imaging Service Request	(0040,2004)	3	
Issuing Time of Imaging Service Request	(0040,2005)	3	
Placer Order Number / Imaging Service Request	(0040,2016)	3	
Filler Order Number / Imaging Service Request	(0040,2017)	3	
Order entered by...	(0040,2008)	3	
Order Enterer's Location	(0040,2009)	3	
Order Callback Phone Number	(0040,2010)	3	
<b>Visit Identification</b>			
Admission ID	(0038,0010)	2	yes
Issuer of Admission ID	(0038,0011)	3	
<b>Visit Status</b>			
Current Patient Location	(0038,0300)	2	yes
<b>Visit Relationship</b>			
Referenced Patient Sequence	(0008,1120)	2	
>Referenced SOP Class UID	(0008,1150)	2	
>Referenced SOP Instance UID	(0008,1155)	2	
<b>Visit Admission</b>			
Institution Name	(0008,0080)	3	yes
Admitting Diagnoses Description	(0008,1080)	3	yes
<b>Patient Identification</b>			
Patient's Name	(0010,0010)	1	yes
Patient ID	(0010,0020)	1	yes
Other Patient IDs	(0010,1000)	3	
Other Patient Names	(0010,1001)	3	
<b>Patient Demographic</b>			
Patients Birth Date	(0010,0030)	2	yes
Patient's Sex	(0010,0040)	2	yes
Patient's Primary Language Code Sequence	(0010,0101)	3	

Attribute Name	Tag	Return Key Type	Displayed in User Interface
>Code Value	(0008,0100)	1	
>Coding Scheme Designator	(0008,0102)	1	
>Code Meaning	(0008,0104)	1	
>Patient's Primary Language Code Modifier Sequence	(0010,0102)	3	
>>Code Value	(0008,0100)	1	
>>Coding Scheme Designator	(0008,0102)	1	
>>Code Meaning	(0008,0104)	1	
Patient's Size	(0010,1020)	3	yes
Patient's Weight	(0010,1030)	2	yes
Confidentiality constraint on patient data	(0040,3001)	2	
Patient's Address	(0010,1040)	3	
Military Rank	(0010,1080)	3	yes
Ethnic Group	(0010,2160)	3	yes
Patient Comments	(0010,4000)	3	yes
<b>Patient Medical</b>			
Patient State	(0038,0500)	2	yes
Pregnancy Status	(0010,21C0)	2	yes
Medical Alerts	(0010,2000)	2	yes
Contrast Allergies	(0010,2110)	2	yes
Special Needs	(0038,0050)	2	yes
Smoking Status	(0010,21A0)	3	yes
Last Menstrual Date	(0010,21D0)	3	yes
Additional Patient History	(0010,21B0)	3	yes

**5.5.2.1.3 Error Handling**

Table 44: indicates the possible response status codes, which a SCP may return following the SCU's C-FIND command. Only those status responses that indicate some form of error condition are presented to the user.

**Table 44: C-FIND Status Responses**

Service Status	Further Meaning	Protocol Codes
Refused	Out of resources	A700
Failed	Identifier does not match SOP Class	A900
	Unable to process	Cxxx
Cancel	Matching terminated due to Cancel request	FE00
Success	Matching is complete - No final Identifier is supplied.	0000
Pending	Matches are continuing - Current Match is supplied and any Optional Keys were supported in the same manner as Required Keys.	FF00
	Matches are continuing - Warning that one or more Optional Keys were not supported for existence and/or for this Identifier.	FF01

**5.6 Modality Performed Procedure Step AE Specification**

The Modality Performed Procedure Step SCU informs the remote SCP about the performed examinations at the modality. The ACUSON Antares system provides Standard Conformance to the following DICOM V3.0 SOP Class as an SCU:

**Table 45: SOP Classes as an SCU**

SOP Class Name	SOP Class UID
Modality Performed Procedure Step	1.2.840.10008.3.1.2.3.3

**5.6.1 Association Establishment Policies**

**5.6.1.1 General**

The configuration of the Antares DICOM Performed Procedure Step application defines the Application Entity Title, the port number, the host name and IP address.

**5.6.1.2 Number of Associations**

The Antares DICOM application initiates one/several association(s) at a time, one for each transfer request being processed.

**5.6.1.3 Asynchronous Nature**

The Antares DICOM software does not support asynchronous communication (multiple outstanding transactions over a single association).

**5.6.1.4 Implementation Identifying Information**

The Antares DICOM software provides a single Implementation Class UID of

- “1.3.12.2.1107.5.9.20000101”

and an Implementation Version Name of

- “SIEMENS\_SWFSYNGO”.

**5.6.2 Association Initiation by Real-World Activity**

The Modality Performed Procedure Step SCU establishes an association by using the DICOM association services.

The following DIMSE-N operations are supported as SCU:

- N-CREATE
- N-SET

**5.6.2.1 Real World Activity**

**5.6.2.1.1 Associated Real-World Activity**

The associated Real-World activity is to send examination information to an SCP by using the DICOM Modality Performed Procedure Step Service.

**5.6.2.1.2 Proposed Presentation Contexts**

The Antares DICOM application will propose Presentation Contexts as shown in the following table:

**Table 46: Proposed Presentation Contexts**

Presentation Context Table					
Abstract Syntax		Transfer Syntax		Role	Extended Negotiation
Name	UID	Name List	UID List		
Modality Performed Procedure Step	1.2.840.10008.3.1.2.3.3	Implicit VR Little Endian	1.2.840.10008.1.2	SCU	None
		Explicit VR Big Endian	1.2.840.10008.1.2.2		
		Explicit VR Little Endian	1.2.840.10008.1.2.1		

**5.6.2.1.3 SOP Specific Conformance Statement**

**Attributes used for the Performed Procedure Step N-CREATE**

The Antares DICOM performed procedure step SCU informs the remote SCP when the examination of a scheduled procedure step will be performed. The N-CREATE message is sent when the examination is started. The following table describes the supported attributes for a N-CREATE message.

**Table 47: Performed Procedure Step N-CREATE Attributes**

Attribute Name	Tag	Required Type	Value
<b>SOP Common</b>			
Specific Character Set	(0008,0005)	1C	from MWL or created
<b>Performed Procedure Step Relationship</b>			
Scheduled Step Attribute Sequence	(0040,0270)	1	
>Study Instance UID	(0020,000D)	1	from MWL or created
>Referenced Study Sequence	(0008,1110)	2	from MWL or zero length
>>Referenced SOP Class UID	(0008,1150)	1C	
>>Referenced SOP Instance UID	(0008,1155)	1C	
>Accession Number	(0008,0050)	2	from MWL or user input
>Placer Order Number / Imaging Service Request	(0040,2016)	3	from MWL or zero length
>Filler Order Number / Imaging Service Request	(0040,2017)	3	from MWL or zero length
>Requested Procedure ID	(0040,1001)	2	from MWL or user input
>Requested Procedure Description	(0032,1060)	2	from MWL or zero length
>Scheduled Procedure Step ID	(0040,0009)	2	from MWL or zero length
>Scheduled Procedure Step Description	(0040,0007)	2	from MWL or zero length
>Scheduled Protocol Code Sequence	(0040,0008)	2	from MWL or zero length
>>Code Value	(0008,0100)	1C	
>>Coding Scheme Designator	(0008,0102)	1C	
>>Code Scheme Version	(0008,0103)	3	
>>Code Meaning	(0008,0104)	3	
Patient's Name	(0010,0010)	2	from MWL or user input

Attribute Name	Tag	Required Type	Value
Patient ID	(0010,0020)	2	from MWL or user input or created
Patients Birth Date	(0010,0030)	2	from MWL or user input
Patient's Sex	(0010,0040)	2	from MWL or user input
Referenced Patient Sequence	(0008,1120)	2	from MWL or zero length
>Referenced SOP Class UID	(0008,1150)	1C	
>Referenced SOP Instance UID	(0008,1155)	1C	
<b>Performed Procedure Step Information</b>			
Performed Procedure Step ID	(0040,0253)	1	from SPS ID or created
Performed Station AE Title	(0040,0241)	1	own AE Title
Performed Station Name	(0040,0242)	2	own hostname
Performed Location	(0040,0243)	2	from SPS Location or zero length
Performed Procedure Step Start Date	(0040,0244)	1	created
Performed Procedure Step Start Time	(0040,0245)	1	created
Performed Procedure Step Status	(0040,0252)	1	IN PROGRESS
Performed Procedure Step Description	(0040,0254)	2	from SPS Description or zero length
Performed Procedure Type Description	(0040,0255)	2	zero length
Procedure Code Sequence	(0008,1032)	2	from Requested Procedure Code or zero length
>Code Value	(0008,0100)	1C	
>Code Scheme Designator	(0008,0102)	1C	
>Code Scheme Version	(0008,0103)	3	
>Code Meaning	(0008,0104)	3	
Performed Procedure Step End Date	(0040,0250)	2	zero length
Performed Procedure Step End Time	(0040,0251)	2	zero length
Comments on the Performed Procedure Step	(0040,0280)	3	from MPPS dialog
<b>Image Acquisition Results</b>			
Modality	(0008,0060)	1	US
Study ID	(0020,0010)	2	from Requested Procedure ID or created
Performed Protocol Code Sequence	(0040,0260)	2	from Scheduled Action Item Code SQ or zero length
>Code Value	(0008,0100)	1C	
>Code Scheme Designator	(0008,0102)	1C	
>Code Scheme Version	(0008,0103)	3	
>Code Meaning	(0008,0104)	3	
Performed Series Sequence	(0040,0340)	2	
>Performing Physicians's Name	(0008,1050)	2C	from MWL or user input
>Protocol Name	(0018,1030)	1C	set to "unknown"
>Operator's Name	(0008,1070)	2C	user input
>Series Instance UID	(0020,000E)	1C	created

Attribute Name	Tag	Required Type	Value
>Series Description	(0008,103E)	2C	zero length
>Retrieve AE Title	(0008,0054)	2C	zero length
>Referenced Image Sequence	(0008,1140)	2C	zero length
>>Referenced SOP Class UID	(0008,1150)	1C	
>>Referenced SOP Instance UID	(0008,1155)	1C	
>Referenced Non-Image Composite SOP Instance Sequence	(0040,0220)	2C	
>>Referenced SOP Class UID	(0008,1150)	1C	
>>Referenced SOP Instance UID	(0008,1155)	1C	
>Referenced Standalone SOP Instance Sequence	(0040,0220)	2C	zero length
<b>Billing and Material Code</b>			
Billing Procedure Step Sequence	(0040,0320)	3	
>Code Value	(0008,0100)	1C	
>Code Scheme Designator	(0008,0102)	1C	
>Code Scheme Version	(0008,0103)	1C	
>Code Meaning	(0008,0104)	1C	
Film Consumption Sequence	(0040,0321)	3	
>Number of Films	(2100,0170)	3	
>Medium Type	(2000,0030)	3	
>Film Size ID	(2010,0050)	3	
Billing Supplies and Devices Sequence	(0040,0324)	3	
>Billing Item Sequence	(0040,0296)	3	
>>Code Value	(0008,0100)	1C	
>>Code Scheme Designator	(0008,0102)	1C	
>>Code Scheme Version	(0008,0103)	1C	
>>Code Meaning	(0008,0104)	1C	
>Quantity Sequence	(0040,0293)	3	
>> Quantity	(0040,0294)	3	
>>Measuring Units Sequence	(0040,0295)	3	
>>>Code Value	(0008,0100)	1C	
>>>Code Scheme Designator	(0008,0102)	1C	
>>>Code Scheme Version	(0008,0103)	1C	
>>>Code Meaning	(0008,0104)	1C	

**Status Codes of the Performed Procedure Step N-CREATE**

The Performed Procedure Step SCU interprets the following status values:

**Table 48: N-CREATE Response Status**

Service Status	Meaning	Status Codes (0000,0900)
Failure	Processing Failure	0110
	No such attribute	0105
	Invalid attribute value	0106
	Duplicate SOP Instance	0111
	No such SOP Instance	0112
	No such SOP class	0118
	Class instance conflict	0119
	Missing attribute	0120
	Missing attribute value	0121
	Resource limitation	0213
Success	Successful Operation	0000

**Attributes used for the Performed Procedure Step N-SET**

The Antares DICOM performed procedure step SCU informs the remote SCP about the performed examination and its status. The N-SET message is only sent once when the exam is ended with status “COMPLETED” or when the examination could not be completed with status “DISCONTINUED”. The following table describes the supported attributes for a N-SET message.

**Table 49: Performed Procedure Step N-SET Attributes**

Attribute name	Tag	Required Type	Value
<b>Performed Procedure Step Information</b>			
Performed Procedure Step Status	(0040,0252)	3	COMPLETED or DISCONTINUED
Performed Procedure Step Description	(0040,0254)	3	from SPS Description or user input
Performed Procedure Type Description	(0040,0255)	3	user input
Procedure Code Sequence	(0008,1032)	3	from Requested Procedure Code
>Code Value	(0008,0100)	1C	
>Code Scheme Designator	(0008,0102)	1C	
>Code Scheme Version	(0008,0103)	3	
>Code Meaning	(0008,0104)	3	
Performed Procedure Step End Date	(0040,0250)	3	created
Performed Procedure Step End Time	(0040,0251)	3	created
<b>Image Acquisition Results</b>			
Performed Action Item Code Sequence	(0040,0260)	3	from Scheduled Action Item Code SQ.
>Code Value	(0008,0100)	1C	
>Code Scheme Designator	(0008,0102)	1C	

Attribute name	Tag	Required Type	Value
>Code Scheme Version	(0008,0103)	3	
>Code Meaning	(0008,0104)	3	
Performed Series Sequence	(0040,0340)	3	
>Performing Physicians's Name	(0008,1050)	2C	from MWL or user input
>Protocol Name	(0018,1030)	1C	user input or set to "unknown"
>Operator's Name	(0008,1070)	2C	user input
>Series Instance UID	(0020,000E)	1C	created
>Series Description	(0008,103E)	2C	user input
>Retrieve AE Title	(0008,0054)	2C	from Storage Commitment RSP or zero length
>Referenced Image Sequence	(0008,1140)	2C	created
>>Referenced SOP Class UID	(0008,1150)	1C	
>>Referenced SOP Instance UID	(0008,1155)	1C	
>Referenced Standalone SOP Instance Sequence	(0040,0220)	2C	zero length
All other attributes from Billing and Material Code Module		3	user input

**Status Codes of the Performed Procedure Step N-SET**

The Performed Procedure Step SCU interprets the following status values:

**Table 50: N-SET Response Status**

Service Status	Meaning	Status Codes (0000,0900)
Failure	Processing Failure: Performed Procedure Step Object may no longer be updated	0110
	No such attribute	0105
	Invalid attribute value	0106
	No such SOP Instance	0112
	Invalid object instance	0117
	No such SOP class	0118
	Class instance conflict	0119
	Missing attribute value	0121
	Resource limitation	0213
Success	Successful Operation	0000

## 6.0 Communication Profiles

All ACUSON Antares system application entities utilize the DICOM 3.0 TCP/IP communication support as defined in PS3.8 (Part 8) of the DICOM 3.0 Standard.

### 6.1 TCP/IP Stack Supported

Each process inherits its TCP/IP stack from the ACUSON Antares's operating system TCP/IP stack. Port number 104 is used for DICOM communication with the Antares.

#### 6.1.1 Physical Media Supported

Standard representations of IEEE 802.3 (10 Base-T and 100 Base-T is supported).

## 7.0 Extensions/Specializations/Privatizations

### 7.1 Standard extended/specialized/private Syntaxes

The ACUSON Antares includes standard extended and private attributes in the US Image and US-MF Image IODs. All standard extended and private attributes are type 3. Support for these attributes by receiving SCPs is not required. See Table 9: US Image IOD Attributes and Table 12: US-MF Image IOD Attributes - 3D Volumetric Data for more information.

### 7.2 Private Transfer Syntaxes

None.

## 8.0 Configuration

ACUSON Antares Networking and DICOM parameters can be configured through the Antares Service configuration UI screens. The following configuration is supported:

- Network (local and remote)
- DICOM Store & Storage Commitment
- DICOM Print
- DICOM Worklist & MPPS

### 8.1 Basic System Configuration

The following system parameters can be configured via the Antares System Presets Basic Menu screens. These parameters are configured in the form of pick lists and are available to the user when registering a patient or correcting patient data. When selected, these parameters are mapped to DICOM image attributes:

- Institution Name (0008, 0080)
- Operators Name (0008,1070)
- Referring Physician (0008,0090)
- Performing Physician (0008,1050)
- Requesting Physician (0032,1032)

## **8.2 DICOM Network Configuration**

DICOM and networking parameters can be configured for both the local Antares device and remote DICOM Service Class Providers through the Local Service Configuration User Interface.

### **8.2.1 Local Host - TCP/IP and General**

The ACUSON Antares local network parameters are configurable. The following network parameters can be configured for Antares device:

- Host Name
- IP address
- Network IP mask
- Router/Gateway IP addresses
- DICOM Storage, Print and HIS/RIS SCU Application Entity Titles

## **8.3 DICOM Storage Configuration**

Remote DICOM Storage and Storage Commitment Service Class Providers are configured through the DICOM - Network Nodes Configuration menu. The following parameters can be configured for each device:

- Host name
- IP address
- AET - Application Entity Title
- Port number
- Proposed transfer syntaxes - (ILE, ELE, EBE, JPEG Lossy, JPEG Lossless)
- Storage Commitment Results in same association as Storage Commitment Request.
- Storage Commitment Results time-out

## **8.4 DICOM HIS/RIS Configuration**

Remote DICOM Worklist and Modality Performed Procedure Step Service Class Providers are configured through the DICOM - HIS/RIS Configuration menu. The following parameters can be configured for each Worklist/MPPS server:

- Host name
- IP address
- AET - Application Entity Title
- Port number
- Query waiting time (in seconds)
- Maximum number of matching results
- Automatic Worklist query interval (in minutes)

## 8.5 DICOM Print Configuration

For each DICOM Print server, the following data is configurable by the user using the Hardcopy Devices page of the Service User Interface. The user can change the page layout and the destination printer at any time during the operation of the Antares. The effect of changing parameters of the DICOM Print server will be seen at the next film sheet. The current film sheet is not affected by changing these parameters.

**Table 51: User Configurable Printer Parameters**

Parameter	Description
Host name	
IP Address	
AE Title	Application Entity Title
Port number	
Color Appearance	Color or monochrome
Print Priority	HIGH= Urgent
Medium Type	CLEAR FILM, BLUE FILM, and Paper
Film Destination	MAGAZINE, PROCESSOR
Max. Density	Used to define the Black value - printer specific
Min. Density	Used to define the White value - printer specific
Transformation	replicate, bilinear, cubic, none
Smoothing	0, 2, 3, 4
Background	Black or White

## 8.6 “Print/Store” Key Configuration

The Antares user can configure “Print/Store” hard keys to “Output Device” mapping through the System Presets - Print/Store Configuration menu. Images are acquired and sent to the assigned device when the user presses the associated key. The following configuration is supported.

### 8.6.1 Multiple Destinations - Auto Transfer

The Antares “Print/Store” keys may be individually configured to transfer images to multiple DICOM Storage devices with a single key press. The system can be configured to automatically transfer images during the exam (with each Print/Store key press) or at the end of the exam (with an End Exam button press or a New Patient or Study). Configuration is on a per destination storage SCP basis.

### 8.6.2 Overlay or Burned in graphics

By default the Antares system burns all text and graphics into the image pixel data. Alternatively, the Antares may be configured to store image text and graphics using the DICOM Overlay module.

### 8.6.3 Secondary Capture Image Storage SOP Class

By default the Antares system stores all static images to the local database using the Ultrasound Image Storage SOP Class. The Antares may be configured to store all static images as Secondary

Capture (Secondary Capture Image Storage SOP Class). This is done to allow image transfer to remote Storage SCPs that do not support the Ultrasound Image Storage SOP Class.

#### 8.6.4 Auto Retry

Auto retry allows images to be automatically resent to destination Storage SCP devices when certain failures have occurred, or if the destination device is offline. The user can configure the retry interval (5 - 60 minutes) and the maximum number of retries (0 - 512). Auto Retry is configured through the Advanced - Transfer Configuration Menu. These are global setting and apply to all configured Storage SCP devices.

#### 8.6.5 Compression

The user may configure the desired compression type (transfer syntax) for image transfer through the Advanced - Transfer Configuration Menu. Configuration is on a per Storage SCP device basis. Choices are:

- None (uses preferred ELE, ILE, EBE transfer syntax)
- JPEG Lossless (Non-Hierarchical, First-Order Prediction - UID = 1.2.840.10008.1.2.4.70)
- JPEG Lossy (JPEG Baseline, Process 1 - UID = 1.2.840.10008.1.2.4.50)

When JPEG Lossy is selected the user can also enter a compression Quality Factor, in percent.

*Note: JPEG Quality factor below 100% may lead to insufficient diagnostic quality of transferred image.*

#### 8.6.6 Print Routing - Auto Transfer

The Antares “Print/Store” keys may be individually configured to transfer images to DICOM Printers, or Local OEM Printers. The “Print/Store” keys may also be individually configured to automatically route images to either a B/W or Color printer based on image content. Routing is determined by the following image types:

1. **B&W**—The image only contains only B&W (grayscale) data.
2. **Color Doppler**—The image contains Color Doppler data.
3. **Tinted**—The image contains only B&W (grayscale) data that is pseudo color tinted.
4. **2D Ref.**—The 2D reference image contains Color Doppler data.
5. **Misc.**—Miscellaneous images. This includes GUI screen captures, external video captures such as VCR, and image review screens containing multiple images.

The user assigns the desired network grayscale or color printer or print server using the “Print/Store” Configuration presets function. Print media size, format and orientation for the selected Printer device can also be configured through the “Print/Store” Presets function.

## 9.0 Media Storage

The ACUSON Antares system is a device that generates ultrasound images that can be saved to CD-R (CD-Recordable) media using DICOM standard protocols and definitions. The applications described refer to the Antares DICOM off-line media storage implementation acting as FSC for the specific application profiles and the related SOP Class instances. The ACUSON Antares system acts as a File Set Reader and Updater only for CD-R discs that were created on an ACUSON Antares system.

### 9.1 Implementation Model

ACUSON Antares system users can store images directly on the system hard disk.

### 9.2 Application Data Flow Diagram

Figure 9: illustrates the ACUSON Antares system's Application Entity (AE) Data Flow Diagram. All relationships between user invoked activities and the associated real-world activities provided by the DICOM archive application are depicted.

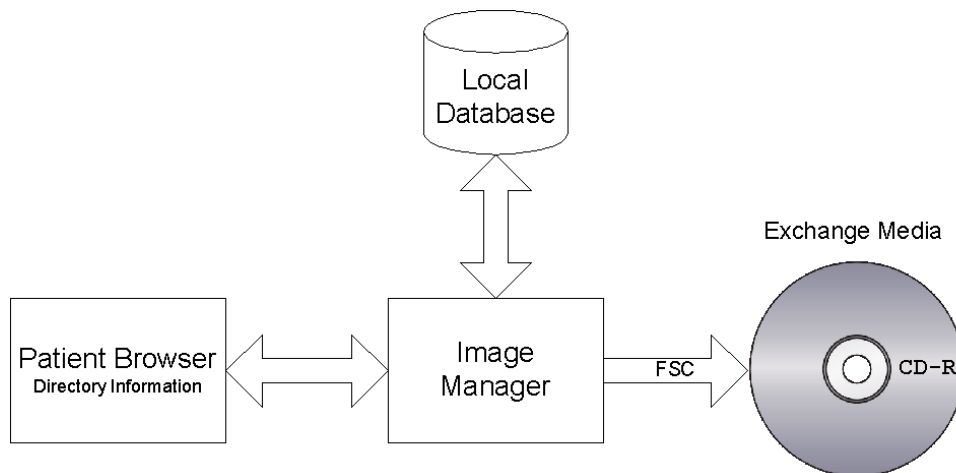

Figure 9: Media Storage Application Data Flow Diagram

## 10.0 Media Storage AE Functional Definition

The ACUSON Antares DICOM offline media storage application consists of the DICOM Image Manager application entity serving all interfaces to access offline media. The DICOM application is capable of:

- Creating a new File set onto an unwritten medium (FSC)
- Updating an existing File set by writing new SOP Instances onto the medium. This is only supported on media that was created on the Antares system.
- Reading the File set's DICOMDIR and displaying the information. This is only supported on media that was created on the Antares system.
- Copying SOP Instances from the medium onto local storage. This is only supported on media and SOP Instances that were created on the Antares system.

**10.1 Real-World Activities for Media Storage**

**10.1.1 Browse Directory Information—Real World Activity**

The Antares application entity is capable of browsing CD DICOM Exchange media and displaying the contents of the DICOMDIR. This is only supported on media that was created on the Antares system.

**10.1.2 Import into Local Storage—Real-World Activity**

The Antares application entity acts as a FSR using the interchange option when requested to import SOP Instances from the CD media into local storage.

The SOP Instance selected from the media directory will be copied into the local storage. This is only supported on media and SOP Instances that were created on the Antares system.

**10.1.3 Export to Local Archive Media—Real-World Activity**

The Antares application acts as a FSC (media not initialized) using the interchange option when requested to copy SOP Instances from the local database to the local archive media (CD-R).

**10.1.4 Sequencing of Real World Activities**

The DICOM Archive application will not perform updates before the Directory information of the DICOMDIR is completely read.

**10.2 AE Specifications**

**10.2.1 Antares Media Storage AE Specification**

The Antares AE provides conformance to the following DICOM SOP Classes as an FSC. The following specifications apply to the AE as depicted in Figure 9: .

When configuring an uncompressed Transfer Syntax, the STD-US and STD-GEN application profile classes will be extended to store instances of the following SOP classes in compressed format.

**Table 52: Application profiles, Activities, and Roles for DICOM Exchange Media**

Application Profiles Supported	Real World Activity	Role	SC Option
STD-GEN-CDR	Create CD-R	FSC †	Interchange
STD-US-SC-MF-CDR	Update CD-R	n/a †	Interchange
STD-US-ID-MF-CDR	Display Directory	n/a †	Interchange
	Copy to Local Storage	n/a †	Interchange

† The ACUSON Antares system acts as a File Set Reader (FSR) and File Set Updater (FSU) for CD-R discs that were created on an ACUSON Antares system.

**10.2.2 File Meta Information Options**

The Implementation Class UID is:

- “1.3.12.2.1107.5.9.20000101”

and an Implementation Version Name of

- “SIEMENS\_SWFSYNGO”.

## 10.3 Media Storage Application Profile

### 10.3.1 DICOMDIR keys

The DICOMDIR file will contain the following attributes for the levels Patient - Study - Series - Image (valid for all Application profiles described in this section).

Table 53: DICOMDIR Keys

Attribute Name	Tag	Type	Notes
<b>File-Set Identification</b>			
File-set ID	(0004,1130)	2	Volume label of media
<b>Directory Information</b>			
Offset of the First Directory Record of the Root Directory Entry	(0004,1200)	1	
Offset of the Last Directory Record of the Root Directory Entry	(0004,1202)	1	
File-set Consistency Flag	(0004,1212)	1	0000H
Directory Record Sequence	(0004,1220)	2	
> Offset of the Next Directory Record	(0004,1400)	1C	
> Record In-use flag	(0004,1410)	1C	FFFFH
> Offset of Referenced Lower-Level Directory Entity	(0004,1420)	1C	
> Directory Record Type	(0004,1430)	1C	PATIENT, STUDY, SERIES, IMAGE
> Referenced File ID	(0004,1500)	1C	contains the filename on media for the Directory Records of Type IMAGE
> Referenced SOP Class UID in File	(0004,1510)	1C	for the Directory Records of Type IMAGE
> Referenced SOP Instance UID in File	(0004,1511)	1C	for the Directory Records of Type IMAGE
> Referenced Transfer Syntax UID in File	(0004,1512)	1C	for the Directory Records of Type IMAGE
> Record Selection Keys	see below		
<b>Patient Keys</b>			<b>Directory Record Type PATIENT</b>
Specific Character Set	(0008,0005)	1C	
Patient's Name	(0010,0010)	2	
Patient ID	(0010,0020)	1	
Date Of Birth	(0010,0030)	3	
Patient's Sex	(0010,0040)	3	
<b>Study Keys</b>			<b>Directory Record Type STUDY</b>
Specific Character Set	(0008,0005)	1C	
Study Date	(0008,0020)	1	
Study Time	(0008,0030)	1	

Attribute Name	Tag	Type	Notes
Accession Number	(0008,0050)	2	
Study Description	(0008,1030)	2	
Study Instance UID	(0020,000D)	1C	
Study ID	(0020,0010)	1	Will be generated automatically, if not present. Value = "-"
<b>Series Keys</b>		<b>Directory Record Type SERIES</b>	
Specific Character Set	(0008,0005)	1C	
Series Date	(0008,0021)	3	
Series Time	(0008,0031)	3	
Modality	(0008,0060)	1	
Institution name	(0008,0080)	3	
Institution Address	(0008,0081)	3	
Series Description	(0008,103E)	3	
Performing Physician	(0008,1050)	3	
Series Instance UID	(0020,000E)	1	
Series Number	(0020,0011)	1	
<b>Image Keys</b>		<b>Directory Record Type IMAGE</b>	
Specific Character Set	(0008,0005)	1C	
Image Type	(0008,0008)	3	
SOP Class UID	(0008,0016)	3	
SOP Instance UID	(0008,0018)	3	
Image Date	(0008,0023)	3	
Image Time	(0008,0033)	3	
Image Number	(0020,0013)	1	
Rows	(0028,0010)	3	
Columns	(0028,0011)	3	
Icon Image Sequence	(0088,0200)	3	
> Samples per Pixel	(0028,0002)		1
> Photometric Interpretation	(0028,0004)		MONOCHROME2 or PALETTE COLOR
> Rows	(0028,0010)		64
> Columns	(0028,0011)		64
> Bits Allocated	(0028,0100)		8
> Bits Stored	(0028,0101)		8
> High Bit	(0028,0102)		7
> Pixel Representation	(0028,0103)		0 (unsigned)
> Pixel Data	(7FE0,0010)		Icon Image pixel data
<b>SR Document Keys</b>		<b>Directory Record Type SR Document</b>	
Specific Character Set	(0008,0005)	1C	
Image Date	(0008,0023)	1	
Image Time	(0008,0033)	1	
Image Number	(0020,0013)	1	

Attribute Name	Tag	Type	Notes
Concept Name Code Sequence	(0040,A043)	1	
> Code Value	(0008,0100)	1C	One of the following combinations: 125000, DCM, OB-GYN Ultrasound Procedure Report 125001, DCM, Vascular Ultrasound Procedure Report 125200, DCM, Adult Echocardiography Procedure Report
> Coding Scheme Designator	(0008,0102)	1C	
> Code Meaning	(0008,0104)	1C	
Completion Flag	(0040,A491)	1	PARTIAL
Verification Flag	(0040,A493)	1	UNVERIFIED

### 10.3.2 Compliance to STD-GEN-CDR

The ACUSON Antares conforms to the STD-GEN-CDR profile. The following SOP Classes will be supported as an FSC.

**Table 54: STD-GEN-CDR Supported SOP Classes**

IOD	SOP Class UID	Transfer Syntax and UID	FSC	FSR	FSU
Secondary Capture Image Storage	1.2.840.10008.5.1.4.1.1.7	Explicit VR Little Endian	Yes	No †	No †

### 10.3.3 Compliance to STD-US-SC-MF-CDR

For media conforming to the STD-US-SC-MF-CDR profiles the following SOP Classes and transfer syntaxes will be supported as an FSC.

**Table 55: STD-US-SC-MF-CDR Supported SOP Classes**

IOD	SOP Class UID	Transfer Syntax and UID	FSC	FSR	FSU
Ultrasound Image Storage	1.2.840.10008.5.1.4.1.1.6.1	Explicit VR Little Endian 1.2.840.10008.1.2.1	Yes	No †	No †
		JPEG Lossy (Baseline) 1.2.840.10008.1.2.4.50			
Ultrasound Multi-frame Image Storage (Clips)	1.2.840.10008.5.1.4.1.1.3.1	JPEG Lossy (Baseline) 1.2.840.10008.1.2.4.50	Yes	No †	No †

The following Photometric Interpretations are supported by FSC:

- RGB - Ultrasound Image Storage only
- YBR\_FULL\_422 - Ultrasound Multi-frame Image Storage (Clips) only

Note: The Antares stores clips locally using JPEG Lossy (Baseline) compression and only has access to the pixel data in lossy compressed form. Conversion to other transfer syntaxes is not supported.

† The ACUSON Antares system acts as a File Set Reader (FSR) and File Set Updater (FSU) only for CD-R discs that were created on an ACUSON Antares system.

**10.3.4 Compliance to STD-US-ID-MF-CDR**

For media conforming to the STD-US-ID-MF-CDR profiles the following SOP Classes and transfer syntaxes will be supported as an FSC.

**Table 56: STD-US-ID-MF-CDR Supported SOP Classes**

IOD	SOP Class UID	Transfer Syntax and UID	FSC	FSR	FSU
Ultrasound Multi-frame Image Storage (3D volumetric data sets)	1.2.840.10008.5.1.4.1.1.3.1	Explicit VR Little Endian 1.2.840.10008.1.2.1	Yes	No †	No †
		JPEG Lossy (Baseline) 1.2.840.10008.1.2.4.50			

The following Photometric Interpretations are supported by FSC:

- MONOCHROME2

Note: The Ultrasound Multi-frame Image Storage SOP is used to transfer Antares Ultrasound 3D volumetric data sets. Each frame represents a single slice from the 3D volume.

† The ACUSON Antares system acts as a File Set Reader (FSR) and File Set Updater (FSU) only for CD-R discs that were created on a ACUSON Antares system.

**10.4 Augmented and Private Profiles**

**10.4.1 Augmented Application Profiles**

When configuring a compressed Transfer Syntax the STD-US and STD-GEN application profile classes will be extended to store instances of the following SOP classes in compressed format.

**Table 57: Augmented Application profiles, Activities, and Roles for DICOM Exchange Media**

Application Profiles Supported	Real World Activity	Role	SC Option
AUG-GEN-CDR	Create CD-R	FSC †	Interchange
AUG-US-SC-MF-CDR	Update CD-R	n/a †	Interchange
AUG-US-ID-MF-CDR	Display Directory	n/a †	Interchange
	Copy to Local Storage	n/a †	Interchange

**10.4.1.1 AUG-GEN-CDR, AUG-US-SC-MF-CDR, AUG-US-ID-MF-CDR**

For media conforming to the AUG-GEN-CDR, AUG-US-SC-MF-CDR and AUG-US-ID-MF-CDR Profile the following SOP classes will be supported as an FSC.

**Table 58: AUG-GEN-CDR, AUG-US-SC-MF-CDR and AUG-US-ID-MF-CDR Supported SOP Classes**

Information Object Definitions	SOP Class UID	Transfer Syntax and UID	FSC	FSR	FSU
US-MF image (3D data set)	1.2.840.10008.5.1.4.1.1.3.1	JPEG Lossless Process 14 1.2.840.10008.1.2.4.70	Yes	No †	No †
US Image	1.2.840.10008.5.1.4.1.1.6.1	JPEG Lossless Process 14 1.2.840.10008.1.2.4.70	Yes	No †	No †
SC Image	1.2.840.10008.5.1.4.1.1.7	JPEG Lossless Process 14 1.2.840.10008.1.2.4.70	Yes	No †	No †
SC Image	1.2.840.10008.5.1.4.1.1.7	JPEG lossy (baseline) 1.2.840.10008.1.2.4.50	Yes	No †	No †
Comprehensive SR	1.2.840.10008.5.1.4.1.1.88.33	Explicit VR Little Endian 1.2.840.10008.1.2.1	Yes	No †	No †

† The ACUSON Antares system acts as a File Set Reader (FSR) and File Set Updater (FSU) only for CD-R discs that were created on an ACUSON Antares system.

**10.4.2 Private Application Profiles**

None.

**10.5 Extensions, Specializations and Privatizations of SOP Classes and Transfer Syntaxes**

None.

**10.6 Configuration**

**10.6.1 AE Title Mapping**

**10.6.1.1 DICOM Media Storage AE Title**

The DICOM Media Storage application (Image Manager) provides the application entity title: CsaImageManager

**10.7 Support of Extended Character Sets**

The Antares system supports the ISO 8859 Latin 1 (ISO-IR 100) character set family and the same family with code extensions (ISO 2022 IR 100 Latin-1).

## 11.0 Appendix A: OB-GYN Structured Report Measurements

This appendix lists the DICOM Structured Report (SR) mappings used in the Obstetric and Gynecologic Structured Reports of Antares SR files, version 5.0.

The mappings are organized in a manner similar to the DICOM SR Templates as described in PS 3.16-2004 of the DICOM Standard. The “Label” column identifies the on-screen report label associated with a measurement. All private code values use the Coding Scheme Designator “99ANTARES”.

The OB-GYN Report mappings follow the DICOM SR Template TID 5000: OB-GYN Ultrasound Procedure Report, except where noted. Amniotic Sacs (for multiple fetuses), Ovaries, Follicles, Cysts, Bladder, and Maternal Kidney are private sections in this release.

For a single fetus, the Amniotic Sac Section and the Umbilical Artery in the Pelvic Vascular Section follow the DICOM Standard. For multiple fetuses, the Amniotic Sac section is a private section and the Umbilical Artery is in the Fetal Vascular Section because the DICOM Standard does not support multiple fetuses for these measurements. These sections are associated with the appropriate fetus.

Notation:

- <L or R> indicates that L or R is in the label name for Left or Right laterality
- < ... Author > means additional author information is provided in a following subsection
- <units> means that the Distance units will be displayed on the report
- [ ... ] is additional information about the label

**TID5000: OB-GYN Ultrasound Procedure Report**

### 11.1 Patient Characteristics

Label	Code Meaning (Coding Scheme Designator, Code Value)	Modifiers	Measurement References
Patient Characteristics	Container: Patient Characteristics (DCM, 121118)		
Indication	Comment (DCM, 121106)		
Height	Patient Height (LN, 8302-2)		
Weight	Patient Weight (LN, 29463-7)		
Gravida	Gravida (LN, 11996-6)		
Para	Para (LN, 11977-6)		
Aborta	Aborta (LN, 11612-9)		

Label	Code Meaning (Coding Scheme Designator, Code Value)	Modifiers	Measurement References
Ectopics	Ectopic Pregnancies (LN, 33065-4)		
BP	Systolic Blood Pressure (SRT, F-008EC)		
	Diastolic Blood Pressure (SRT, F-008ED)		

### 11.2 OB-GYN Summary

Label	Code Meaning (Coding Scheme Designator, Code Value)	Modifiers	Measurement References
<b>OB-GYN Summary</b>	Container: Summary (DCM, 121111)		
No. Fetuses	Number of Fetuses (LN, 11878-6)		
Additional Info.	Comment (DCM, 121106)		
Comments	Comment (DCM, 121106)		
EDC	EDD (LN, 11778-8)		
LMP	LMP (LN, 11955-2)		
IVF	IVF Date (99ANTARES, IVFDate)		

### 11.3 Fetus Summary

Label	Code Meaning (Coding Scheme Designator, Code Value)	Modifiers	Measurement References
<b>Fetus Summary</b>	Container: Fetus Summary (DCM, 125008)		
Clinical Age	Gestational Age (LN, 18185-9)		
US Age <Author Label>	Composite Ultrasound Age (LN, 11888-5)	< US Age Author Information>	
US Age <Author Label> +/-	2 Sigma deviation of population (DCM, 121417)		Composite Ultrasound Age (LN, 11888-5) <US Age Author Information>
EFW <Author Label>	Estimated Weight (LN, 11727-5)	<EFW Author Information>	
EFW <Author Label> +/-	2 Sigma Deviation of Population (DCM, 121417)		Estimated Weight (LN, 11727-5) <EFW Author Information>
EFW% <Author Label>	EFW percentile rank (LN, 11767-1)	<EFW% Author Information>	Estimated Weight (LN, 11727-5)
EFW <Author Label>	Gestational Age (LN, 18185-9)	<EFW Gestational Age Author Information>	Estimated Weight (LN, 11727-5)
Fetal HR	Fetal Heart Rate (LN, 11948-7)		
US EDC	EDC using Composite Age (99ANTARES, CompositeEdc)		

**11.3.1 US Age Authors**

Author Label	Author Information	Comments
Average	Equation: Average Ultrasound Age (LN, 11884-4)	
Hadlock (BPD, HC, AC, FL)	Equation: Composite GA, Hadlock BPD, HC, AC, FL (99ANTARES,CompGAHadlock1)	
Hadlock (BPD, HC, AC)	Equation: Composite GA, Hadlock BPD, HC, AC (99ANTARES, CompGAHadlock2)	
Hadlock (HC, AC, FL)	Equation: Composite GA, Hadlock HC, AC, FL (99ANTARES, CompGAHadlock3)	
Hadlock (BPD, HC, FL)	Equation: Composite GA, Hadlock BPD, HC, FL (99ANTARES, CompGAHadlock4)	
Hadlock (BPD, AC, FL)	Equation: Composite GA, Hadlock BPD, AC, FL (99ANTARES, CompGAHadlock5)	
Hadlock (AC, FL)	Equation: Composite GA, Hadlock AC, FL (99ANTARES, CompGAHadlock6)	
Hadlock (HC, FL)	Equation: Composite GA, Hadlock HC, FL (99ANTARES, CompGAHadlock7)	
Hadlock (HC, AC)	Equation: Composite GA, Hadlock HC, AC (99ANTARES, CompGAHadlock8)	
Hadlock (BPD, FL)	Equation: Composite GA, Hadlock BPD, FL (99ANTARES, CompGAHadlock9)	
Hadlock (BPD, HC)	Equation: Composite GA, Hadlock BPD, HC (99ANTARES, CompGAHadlock10)	
Hadlock (BPD, AC)	Equation: Composite GA, Hadlock BPD, AC (99ANTARES, CompGAHadlock11)	

**11.3.2 EFW Authors**

Author Label	Author Information	Comments
Hadlock (BPD, HC, AC, FL)	Equation: EFW by AC, BPD, FL, HC, Hadlock 1985 (LN, 11732-5)	
Hadlock (BPD, AC, FL)	Equation: EFW by AC, BPD, FL, Hadlock 1985 (LN, 11735-8)	
Hadlock (HC, AC, FL)	Equation: EFW by AC, FL, HC, Hadlock 1985 (LN, 11746-5)	
Hadlock (AC, FL)	Equation: EFW by AC, FL, Hadlock 1985 (LN, 11751-5)	
Shepard (BPD, AC)	Equation: EFW by AC, BPD, Shepard 1982 (LN, 11739-0)	
Tokyo (BPD, APAD, TAD, FL)	Equation: EFW by BPD, APAD, TAD, FL, Tokyo 1987 (LN, 33144-7)	No associated "2 Sigma Deviation of Population" value.
Osaka (BPD, FTA, FL)	Equation: EFW by BPD, FTA, FL, Osaka 1990 (LN, 33140-5)	No associated "2 Sigma Deviation of Population" value.
JSUM (BPD, AC, FL)	Equation: EFW by BPD, AC, FL, JSUM (99ANTARES, EFWJSUMBpdAcFl)	No associated "2 Sigma Deviation of Population" value.
JSUM (BPD, APAD, TAD, FL)	Equation: EFW by BPD, APAD, TAD, FL, JSUM (99ANTARES, EFWJSUMBpdApad)	No associated "2 Sigma Deviation of Population" value.
Merz (BPD, AC)	Equation: EFW by BPD, AC, Merz (99ANTARES, EFWMerzBpdAc)	

### 11.3.3 EFW% Authors

Author Label	EFW Growth Author Information	Comments
Hadlock	Equation: FWP by GA, Hadlock 1991 (LN, 33162-9)	
Williams	Equation: FWP by GA, Williams 1982 (LN, 33184-3)	
Jeanty	Equation: FWP by GA, Jeanty (99ANTARES, GCEFWJeanty)	
Yarkoni	Equation: FWP by GA, Yarkoni (99ANTARES, GCEFWYarkoni)	
JSUM	Equation: FWP by GA, JSUM (99ANTARES, GCEFWJSUM)	
Tokyo	Equation: FWP by GA, Tokyo (99ANTARES, GCEFWTokyo)	
Osaka	Equation: FWP by GA, Osaka (99ANTARES, GCEFWOsaka)	

### 11.3.4 EFW Gestational Age Authors

Author Label	EFW Author Information	Comments
Tokyo	Table: EFW GA Tokyo (99ANTARES, EFWGATokyo)	No associated "2 Sigma Deviation of Population" value.
Osaka	Table: EFW GA Osaka (99ANTARES, EFWGAOsaka)	No associated "2 Sigma Deviation of Population" value.
JSUM	Table: EFW GA JSUM (99ANTARES, EFWGAJSUM)	No associated "2 Sigma Deviation of Population" value.

## 11.4 Fetal Biometry Ratios

[Note: The Code Value for the Normal Range Lower Limit is incorrectly listed as (SRT, R-10041) in the DICOM Standard, Part 16. The correct code is used in this release.]

Label	Code Meaning (Coding Scheme Designator, Code Value)	Modifiers	Measurement References
<b>Fetal Biometry Ratios</b>	Container: Fetal Biometry Ratios (DCM, 125001)		
HC/AC Ratio	HC/AC (LN, 11947-9)		
HC/AC Range High	Normal Range Upper Limit (SRT, R-0038B)		HC/AC (LN, 11947-9)
HC/AC Range Low	Normal Range Lower Limit (SRT, R-41F90)		HC/AC (LN, 11947-9)
FL/AC Ratio	FL/AC (LN, 11871-1)		
FL/AC Range High	Normal Range Upper Limit (SRT, R-0038B)		FL/AC (LN, 11871-1)
FL/AC Range Low	Normal Range Lower Limit (SRT, R-41F90)		FL/AC (LN, 11871-1)
FL/BPD Ratio	FL/BPD (LN, 11872-9)		
FL/BPD Range High	Normal Range Upper Limit (SRT, R-0038B)		FL/BPD (LN, 11872-9)
FL/BPD Range Low	Normal Range Lower Limit (SRT, R-41F90)		FL/BPD (LN, 11872-9)
CI Ratio	Cephalic Index (LN, 11823-2)		
CI Range High	Normal Range Upper Limit (SRT, R-0038B)		Cephalic Index (LN, 11823-2)
CI Range Low	Normal Range Lower Limit (SRT, R-41F90)		Cephalic Index (LN, 11823-2)

Label	Code Meaning (Coding Scheme Designator, Code Value)	Modifiers	Measurement References
FL/HC Ratio	FL/HC (LN, 11873-7)		
FL/HC Range High	Normal Range Upper Limit (SRT, R-0038B)		FL/HC (LN, 11873-7)
FL/HC Range Low	Normal Range Lower Limit (SRT, R-41F90)		FL/HC (LN, 11873-7)
TCD/AC	TCD/AC (99ANTARES, RatioTCDAC)		
TCD/AC Range High	Normal Range Upper Limit (SRT, R-0038B)		TCD/AC (99ANTARES, RatioTCDAC)
TCD/AC Range Low	Normal Range Lower Limit (SRT, R-41F90)		TCD/AC (99ANTARES, RatioTCDAC)
LVW/HW	LVW OVER HW RATIO (99ANTARES, RatioLVWHW)		
LVW/HW Range High	Normal Range Upper Limit (SRT, R-0038B)		LVW OVER HW RATIO (99ANTARES, RatioLVWHW)
LVW/HW Range Low	Normal Range Lower Limit (SRT, R-41F90)		LVW OVER HW RATIO (99ANTARES, RatioLVWHW)
HA/TA	HA/TA (99ANTARES, RatioHATA)		

### 11.5 Fetal Biometry Measurements

Label	Code Meaning (Coding Scheme Designator, Code Value)	Modifiers	Measurement References
<b>Fetal Biometry Measurements</b>	Container: Fetal Biometry (DCM, 125002)		
AC	Abdominal Circumference (LN, 11979-2)		
AC <Gestational Age Author>	Gestational Age (LN, 18185-9)	<AC Gestational Age Author Information>	Abdominal Circumference (LN, 11979-2)
AC <Gestational Age Author> 2SD	2 Sigma Deviation of Population (DCM, 121417)		Gestational Age (LN, 18185-9) <AC Gestational Age Author Information> Abdominal Circumference (LN, 11979-2)
AC Mean	Abdominal Circumference (LN, 11979-2)	Derivation: Mean (SRT, R-00317)	
AC <Growth Author>	Growth Percentile Rank (DCM, 125012)	<AC Growth Author Information>	Abdominal Circumference (LN, 11979-2)
APAD	Anterior Posterior Abdominal Diameter (LN, 11818-2)		
APAD Mean	Anterior Posterior Abdominal Diameter (LN, 11818-2)	Derivation: Mean (SRT, R-00317)	
BPD	Biparietal Diameter (LN, 11820-8)		
BPD <Gestational Age Author>	Gestational Age (LN, 18185-9)	<BPD Gestational Age Author Information>	Biparietal Diameter (LN, 11820-8)
BPD <Gestational Age Author> 2SD	2 Sigma Deviation of Population (DCM, 121417)		Gestational Age (LN, 18185-9) <BPD Gestational Age Author Information> Biparietal Diameter (LN, 11820-8)
BPD Mean	Biparietal Diameter (LN, 11820-8)	Derivation: Mean (SRT, R-00317)	
BPD <Growth Author>	Growth Percentile Rank (DCM, 125012)	<BPD Growth Author Information>	Biparietal Diameter (LN, 11820-8)

Label	Code Meaning (Coding Scheme Designator, Code Value)	Modifiers	Measurement References
FL	Femur Length (LN, 11963-6)		
FL <Gestational Age Author>	Gestational Age (LN, 18185-9)	<FL Gestational Age Author Information>	Femur Length (LN, 11963-6)
FL <Gestational Age Author> 2SD	2 Sigma Deviation of Population (DCM, 121417)		Gestational Age (LN, 18185-9) <FL Gestational Age Author Information> Femur Length (LN, 11963-6)
FL Mean	Femur Length (LN, 11963-6)	Derivation: Mean (SRT, R-00317)	
FL <Growth Author>	Growth Percentile Rank (DCM, 125012)	<FL Growth Author Information>	Femur Length (LN, 11963-6)
Foot	Foot Length (LN, 11965-1)		
Foot, Author: Mercer	Gestational Age (LN, 18185-9)	Equation: Foot Length, Mercer 1987 (LN, 11926-3)	Foot Length (LN, 11965-1)
Foot, Author: Mercer, 2SD	2 Sigma Deviation of Population (DCM, 121417)		Gestational Age (LN, 18185-9) Equation: Foot Length, Mercer 1987 (LN, 11926-3) Foot Length (LN, 11965-1)
Foot Mean	Foot Length (LN, 11965-1)	Derivation: Mean (SRT, R-00317)	
HC	Head Circumference (LN, 11984-2)		
HC <Gestational Age Author>	Gestational Age (LN, 18185-9)	<HC Gestational Age Author Information>	Head Circumference (LN, 11984-2)
HC <Gestational Age Author> 2SD	2 Sigma Deviation of Population (DCM, 121417)		Gestational Age (LN, 18185-9) <HC Gestational Age Author Information> Head Circumference (LN, 11984-2)
HC Mean	Head Circumference (LN, 11984-2)	Derivation: Mean (SRT, R-00317)	
HC <Growth Author>	Growth Percentile Rank (DCM, 125012)	<HC Growth Author Information>	Head Circumference (LN, 11984-2)
OFD	Occipital Frontal Diameter (LN, 11851-3)		
OFD, Author: ASUM2000	Gestational Age (LN, 18185-9)	Equation: OFD, ASUM 2000 (LN, 33119-9)	Occipital Frontal Diameter (LN, 11851-3)
OFD Mean	Occipital Frontal Diameter (LN, 11851-3)	Derivation: Mean (SRT, R-00317)	
OFD, Growth Author: ASUM2000	Growth Percentile Rank (DCM, 125012)	Table: OFD by GA, ASUM 2000 (LN, 33178-5)	Occipital Frontal Diameter (LN, 11851-3)
TC	Thoracic Circumference (LN, 11988-3)		
TC Mean	Thoracic Circumference (LN, 11988-3)	Derivation: Mean (SRT, R-00317)	
TA	Thoracic Area (LN, 33068-8)		
TA Mean	Thoracic Area (LN, 33068-8)	Derivation: Mean (SRT, R-00317)	
TAD	Transverse Abdominal Diameter (LN, 11862-0)		
TAD Mean	Transverse Abdominal Diameter (LN, 11862-0)	Derivation: Mean (SRT, R-00317)	
TAD, Growth Author: CFEF	Growth Percentile Rank (DCM, 125012)	Table: TAD by GA CFEF (99ANTARES, GCTADCFEF)	Transverse Abdominal Diameter (LN, 11862-0)
2D-Mode: L Kidney mm	Left Kidney Length (LN, 11834-9)		

Label	Code Meaning (Coding Scheme Designator, Code Value)	Modifiers	Measurement References
2D-Mode: L Kidney Mean	Left Kidney Length (LN, 11834-9)	Derivation: Mean (SRT, R-00317)	
2D-Mode: R Kidney mm	Right Kidney Length (LN, 11836-4)		
2D-Mode: R Kidney Mean	Right Kidney Length (LN, 11836-4)	Derivation: Mean (SRT, R-00317)	
APAD x TAD	APAD*TAD (LN, 33191-8)		
APAD x TAD, Author: Tokyo	Gestational Age (LN, 18185-9)	Table: APAD*TAD, Tokyo (99ANTARES, APADxTADGATokyo)	APAD*TAD (LN, 33191-8)
APAD x TAD Mean	APAD*TAD (LN, 33191-8)	Derivation: Mean (SRT, R-00317)	
APAD x TAD, Growth Author: Tokyo	Growth Percentile Rank (DCM, 125012)	Table: APAD TIMES TAD by GA Tokyo (99ANTARES, GCAPADxTADTokyo)	APAD*TAD (LN, 33191-8)
HA	Heart Area (99ANTARES, HeartArea)		
FTA	Fetal Trunk Area (99ANTARES, FTrunkArea)		
FTA, Author: Osaka	Gestational Age (LN, 18185-9)	Table: FTA, Osaka 1989 (LN, 33138-9)	Fetal Trunk Area (99ANTARES, FTrunkArea)
FTA Mean	Fetal Trunk Area (99ANTARES, FTrunkArea)	Derivation: Mean (SRT, R-00317)	
FTA, Growth Author: Osaka	Growth Percentile Rank (DCM, 125012)	Table: FTA by GA Osaka (99ANTARES, GCFTAOsaka)	Fetal Trunk Area (99ANTARES, FTrunkArea)
HC/AC, Growth Author: Campbell	Growth Percentile Rank (DCM, 125012)	Table: HC/AC by GA, Campbell 1977 (LN, 33182-7)	
Volume: L Kidney V	Left Fetal Kidney Volume (99ANTARES, LFKidneyVol)		
Volume: L Kidney Mean	Left Fetal Kidney Volume (99ANTARES, LFKidneyVol)	Derivation: Mean (SRT, R-00317)	
Volume: L Kidney D1	Left Fetal Kidney Volume: Distance 1 (99ANTARES, LFKidneyVolD1)		
Volume: L Kidney D2	Left Fetal Kidney Volume: Distance 2 (99ANTARES, LFKidneyVolD2)		
Volume: L Kidney D3	Left Fetal Kidney Volume: Distance 3 (99ANTARES, LFKidneyVolD3)		
Volume: R Kidney V	Right Fetal Kidney Volume (99ANTARES, RFKidneyVol)		
Volume: R Kidney Mean	Right Fetal Kidney Volume (99ANTARES, RFKidneyVol)	Derivation: Mean (SRT, R-00317)	
Volume: R Kidney D1	Right Fetal Kidney Volume: Distance 1 (99ANTARES, RFKidneyVolD1)		
Volume: R Kidney D2	Right Fetal Kidney Volume: Distance 2 (99ANTARES, RFKidneyVolD2)		

Label	Code Meaning (Coding Scheme Designator, Code Value)	Modifiers	Measurement References
Volume: R Kidney D3	Right Fetal Kidney Volume: Distance 3 (99ANTARES, RFKidneyVolD3)		

**11.5.1 AC Gestational Age Authors**

Author Label	AC Gestational Age Author Information	Comments
ASUM2000	Equation: AC, ASUM 2000 (LN, 33072-0)	No associated “2 Sigma Deviation of Population” value.
Hadlock	Equation: AC, Hadlock 1984 (LN, 11892-7)	
ASUM	Equation: AC GA ASUM (99ANTARES, ACGAASUM)	No associated “2 Sigma Deviation of Population” value.
Lasser	Table: AC GA Lasser (99ANTARES, ACGALasser)	
Merz	Table: AC GA Merz (99ANTARES, ACGAMerz)	
JSUM	Table: AC GA JSUM (99ANTARES, ACGAJSUM)	

**11.5.2 AC Growth Authors**

Author Label	AC Growth Author Information	Comments
Hadlock	Equation: AC by GA, Hadlock 1984 (LN, 33146-2)	
Merz	Table: AC by GA, Merz 1988 (LN, 33148-8)	
Chitty	Equation: AC (measured) by GA, Chitty 1994 (LN, 33147-0)	
ASUM2000	Table: AC by GA, ASUM 2000 (LN, 33145-4)	
Jeanty	Table: AC by GA Jeanty (99ANTARES, GCACJeanty)	
ASUM	Equation: AC by GA ASUM (99ANTARES, GCACASUM)	
Grumback	Table: AC by GA Grumback (99ANTARES, GCACGrumback)	
Deter	Equation: AC by GA Deter (99ANTARES, GCACDeter)	
JSUM	Table: AC by GA JSUM (99ANTARES, GCACJSUM)	
CFEF	Table: AC by GA CFEF (99ANTARES, GCACCFEF)	

**11.5.3 BPD Gestational Age Authors**

Author Label	BPD Gestational Age Author Information	Comments
Hadlock	Equation: BPD, Hadlock 1984 (LN, 11902-4)	
Hansmann	Table: BPD, Hansmann 1986 (LN, 33538-0)	
Rempen	Table: BPD, Rempen 1991 (LN, 33083-7)	
ASUM	Table: BPD, ASUM 1989 (LN, 33079-5)	
Tokyo	Table: BPD, Tokyo 1986 (LN, 33085-2)	No associated “2 Sigma Deviation of Population” value.
Osaka	Table: BPD, Osaka 1989 (LN, 33082-9)	No associated “2 Sigma Deviation of Population” value.
ASUM2000	Equation: BPD GA ASUM2000 (99ANTARES, BPDGAASUM2000)	No associated “2 Sigma Deviation of Population” value.

Author Label	BPD Gestational Age Author Information	Comments
Lasser	Table: BPD GA Lasser (99ANTARES, BPDGALasser)	
Merz	Table: BPD GA Merz (99ANTARES, BPDGAMerz)	
JSUM	Table: BPD GA JSUM (99ANTARES, BPDGAJSUM)	

**11.5.4 BPD Growth Authors**

Author Label	BPD Growth Author Information	Comments
Hadlock	Equation: BPD by GA, Hadlock 1984 (LN, 33198-3)	
Merz	Table: BPD by GA, Merz 1988 (LN, 33154-6)	
Rempen	Table: BPD by GA, Rempen 1991 (LN, 33155-3)	
Chitty (out-to-in)	Equation: BPD outer inner by GA, Chitty 1994 (LN, 33556-2)	
Chitty (out-to-out)	Equation: BPD outer outer by GA, Chitty 1994 (LN, 33152-0)	
ASUM2000	Table: BPD by GA, ASUM 2000 (LN, 33151-2)	
Hansmann	Table: BPD by GA Hansmann (99ANTARES, GCBPDHansmann)	
Lasser	Equation: BPD by GA Lasser (99ANTARES, GCBPDLasser)	
Grumback	Table: BPD by GA Grumback (99ANTARES, GCBPDGrumback)	
JSUM	Table: BPD by GA JSUM (99ANTARES, GCBPDJSUM)	
Tokyo	Table: BPD by GA Tokyo (99ANTARES, GCBPDTokyo)	
Osaka	Table: BPD by GA Osaka (99ANTARES, GCBPDOsaka)	
CFEF	Table: BPD by GA CFEF (99ANTARES, GCBPDCFEF)	
ASUM	Table: BPD by GA ASUM (99ANTARES, GCBPDASUM)	

**11.5.5 FL Gestational Age Authors**

Author Label	FL Gestational Age Author Information	Comments
Hadlock	Equation: FL, Hadlock 1984 (LN, 11920-6)	
Jeanty	Equation: FL, Jeanty 1984 (LN, 11923-0)	
Merz	Table: FL, Merz 1988 (LN, 33542-2)	
Tokyo	Table: FL, Tokyo 1986 (LN, 33103-3)	No associated “2 Sigma Deviation of Population” value.
Osaka	Table: FL, Osaka 1989 (LN, 33101-7)	No associated “2 Sigma Deviation of Population” value.
ASUM	Equation: FL GA ASUM (99ANTARES, FLGAASUM)	
ASUM2000	Equation: FL GA ASUM2000 (99ANTARES, FLGAASUM2000)	No associated “2 Sigma Deviation of Population” value.
Warda	Equation: FL GA Warda (99ANTARES, FLGAWarda)	
JSUM	Table: FL GA JSUM (99ANTARES, FLGAJSUM)	

**11.5.6 FL Growth Authors**

Author Label	FL Growth Author Information	Comments
Hadlock	Equation: FL by GA, Hadlock 1984 (LN, 33166-0)	
Jeanty	Equation: FL by GA, Jeanty 1982 (LN, 33168-6)	
Merz	Table: FL by GA, Merz 1988 (LN, 33169-4)	
Chitty	Equation: FL by GA, Chitty 1994 (LN, 33167-8)	
ASUM2000	Table: FL by GA, ASUM 2000 (LN, 33165-2)	
Warda	Equation: FL by GA Warda (99ANTARES, GCFLWarda)	
JSUM	Table: FL by GA JSUM (99ANTARES, GCFLJSUM)	
Tokyo	Table: FL by GA Tokyo (99ANTARES, GCFLTokyo)	
Osaka	Table: FL by GA Osaka (99ANTARES, GCFLOsaka)	
CFEF	Table: FL by GA CFEF (99ANTARES, GCFLCFEF)	
ASUM	Equation: FL by GA ASUM (99ANTARES, GCFLASUM)	

**11.5.7 HC Gestational Age Authors**

Author Label	HC Gestational Age Author Information	Comments
ASUM2000	Equation: HC, ASUM 2000 (LN, 33109-0)	No associated “2 Sigma Deviation of Population” value.
Hadlock	Equation: HC, Hadlock 1984 (LN, 11932-1)	
Hansmann	Table: HC, Hansmann 1986 (LN, 33543-0)	
Merz	Table: HC, Merz 1988 (LN, 33115-7)	
Lasser	Table: HC GA Lasser (99ANTARES, HCGALasser)	

**11.5.8 HC Growth Authors**

Author Label	HC Growth Author Information	Comments
Hadlock	Equation: HC by GA, Hadlock 1984 (LN, 33173-6)	
Merz	Table: HC by GA, Merz 1988 (LN, 33176-9)	
Chitty	Equation: HC derived by GA, Chitty 1994 (LN, 33174-4)	
ASUM2000	Table: HC by GA, ASUM 2000 (LN, 33172-8)	
Hansmann	Table: HC by GA Hansmann (99ANTARES, GCHCHansmann)	
ASUM	Equation: HC by GA ASUM (99ANTARES, GCHCASUM)	
Deter	Equation: HC by GA Deter (99ANTARES, GCHCDeter)	
CFEF	Table: HC by GA CFEF (99ANTARES, GCHCCFEF)	

**11.6 Fetal Long Bones Biometry Measurements**

Label	Code Meaning (Coding Scheme Designator, Code Value)	Modifiers	Measurement References
<b>Fetal Long Bones Biometry Measurements</b>	Container: Fetal Long Bones (DCM, 125003)		
Clavicle	Clavicle Length (LN, 11962-8)		
Clavicle, Author: Yarkoni	Gestational Age (LN, 18185-9)	Equation: Clavical Length, Yarkoni 1985 (LN, 33088-6)	Clavicle Length (LN, 11962-8)
Clavicle, Author: Yarkoni, 2SD	2 Sigma Deviation of Population (DCM, 121417)		Gestational Age (LN, 18185-9) Equation: Clavical Length, Yarkoni 1985 (LN, 33088-6) Clavicle Length (LN, 11962-8)
Clavicle Mean	Clavicle Length (LN, 11962-8)	Derivation: Mean (SRT, R-00317)	
HL	Humerus Length (LN, 11966-9)		
HL <Gestational Age Author>	Gestational Age (LN, 18185-9)	<HL Gestational Age Author Information>	Humerus Length (LN, 11966-9)
HL <Gestational Age Author> 2SD	2 Sigma Deviation of Population (DCM, 121417)		Gestational Age (LN, 18185-9) <HL Gestational Age Author Information> Humerus Length (LN, 11966-9)
HL Mean	Humerus Length (LN, 11966-9)	Derivation: Mean (SRT, R-00317)	
HL <Growth Author>	Growth Percentile Rank (DCM, 125012)	<HL Growth Author Information>	Humerus Length (LN, 11966-9)
Radius	Radius Length (LN, 11967-7)		
Radius Mean	Radius Length (LN, 11967-7)	Derivation: Mean (SRT, R-00317)	
Tibia	Tibia Length (LN, 11968-5)		
Tibia, Author: Jeanty	Gestational Age (LN, 18185-9)	Equation: Tibia, Jeanty 1984 (LN, 11941-2)	Tibia Length (LN, 11968-5)
Tibia, Author: Jeanty, 2SD	2 Sigma Deviation of Population (DCM, 121417)		Gestational Age (LN, 18185-9) Equation: Tibia, Jeanty 1984 (LN, 11941-2) Tibia Length (LN, 11968-5)
Tibia Mean	Tibia Length (LN, 11968-5)	Derivation: Mean (SRT, R-00317)	
Ulna	Ulna Length (LN, 11969-3)		
Ulna, Author: Jeanty	Gestational Age (LN, 18185-9)	Equation: Ulna, Jeanty 1984 (LN, 11944-6)	Ulna Length (LN, 11969-3)
Ulna, Author: Jeanty, 2SD	2 Sigma Deviation of Population (DCM, 121417)		Gestational Age (LN, 18185-9) Equation: Ulna, Jeanty 1984 (LN, 11944-6) Ulna Length (LN, 11969-3)
Ulna Mean	Ulna Length (LN, 11969-3)	Derivation: Mean (SRT, R-00317)	

**11.6.1 HL Gestational Age Authors**

Author Label	HL Gestational Age Author Information	Comments
ASUM 2000	Equation: Humerus Length, ASUM 2000 (LN, 33116-5)	No associated "2 Sigma Deviation of Population" value.
Jeanty	Equation: Humerus, Jeanty 1984 (LN, 11936-2)	
Osaka	Table: Humerus Length, Osaka 1989 (LN, 33117-3)	No associated "2 Sigma Deviation of Population" value.

**11.6.2 HL Growth Authors**

Author Label	HL Growth Author Information	Comments
ASUM2000	Table: Humerus Length by GA, ASUM 2000 (LN, 33177-7)	
Jeanty	Equation: HL by GA Jeanty (99ANTARES, GCHLJeanty)	
Merz	Table: HL by GA Merz (99ANTARES, GCHLMerz)	
Osaka	Table: HL by GA Osaka (99ANTARES, GCHLOsaka)	

**11.7 Fetal Cranium**

Label	Code Meaning (Coding Scheme Designator, Code Value)	Modifiers	Measurement References
<b>Fetal Cranium</b>	Container: Fetal Cranium (DCM, 125004)		
LVW	Lateral Ventricular Width (LN, 12171-5)		
LVW Mean	Lateral Ventricular Width (LN, 12171-5)	Derivation: Mean (SRT, R-00317)	
Cist Magna	Cisterna Magna (LN, 11860-4)		
Cist Magna Mean	Cisterna Magna (LN, 11860-4)	Derivation: Mean (SRT, R-00317)	
Nuchal Thick	Nuchal Fold Thickness (LN, 12146-7)		
Nuchal Thick Mean	Nuchal Fold Thickness (LN, 12146-7)	Derivation: Mean (SRT, R-00317)	
Binoc D	Outer Orbital Diameter (LN, 11629-3)		
Binoc D <Gestational Age Author>	Gestational Age (LN, 18185-9)	<Binoc D Gestational Age Author Information>	Outer Orbital Diameter (LN, 11629-3)
Binoc D <Gestational Age Author> 2SD	2 Sigma Deviation of Population (DCM, 121417)		Gestational Age (LN, 18185-9) <Binoc D Gestational Age Author Information> Outer Orbital Diameter (LN, 11629-3)
Binoc D Mean	Outer Orbital Diameter (LN, 11629-3)	Derivation: Mean (SRT, R-00317)	
TCD	Trans Cerebellar Diameter (LN, 11863-8)		
TCD Mean	Trans Cerebellar Diameter (LN, 11863-8)	Derivation: Mean (SRT, R-00317)	
HW	Width of Hemisphere (LN, 12170-7)		
HW Mean	Width of Hemisphere (LN, 12170-7)	Derivation: Mean (SRT, R-00317)	

**11.7.1 Binoc D Gestational Age Authors**

Author Label	Binoc D Gestational Age Author Information	Comments
Jeanty	Table: Binoc D, Jeanty (99ANTARES, BNGAJeanty)	
Tongsong	Equation: Binoc D, Tongsong (99ANTARES, BNGATongsong)	

**11.8 Amniotic Sac**

[Note: AFI values appear in a private Amniotic Sacs section when there are multiple fetuses.]

Label	Code Meaning (Coding Scheme Designator, Code Value)	Modifiers	Measurement References
<b>Amniotic Sac</b>	Finding Site: Amniotic Sac (SRT, T-F1300)		
AFI Sum	Amniotic Fluid Index (LN, 11627-7)		
AFI Q1	First Quadrant Diameter (LN, 11624-4)		
AFI Q2	Second Quadrant Diameter (LN, 11626-9)		
AFI Q3	Third Quadrant Diameter (LN, 11625-1)		
AFI Q4	Fourth Quadrant Diameter (LN, 11623-6)		

**11.9 Early Gestation Biometry Measurements**

Label	Code Meaning (Coding Scheme Designator, Code Value)	Modifiers	Measurement References
<b>Early Gestation Biometry Measurements</b>	Container: Early Gestation (DCM, 125009)		
CRL	Crown Rump Length (LN, 11957-8)		
CRL <Gestational Age Author>	Gestational Age (LN, 18185-9)	<CRL Gestational Age Author Information>	Crown Rump Length (LN, 11957-8)
CRL <Gestational Age Author> 2SD	2 Sigma Deviation of Population (DCM, 121417)		Gestational Age (LN, 18185-9) <CRL Gestational Age Author Information> Crown Rump Length (LN, 11957-8)
CRL Mean	Crown Rump Length (LN, 11957-8)	Derivation: Mean (SRT, R-00317)	
CRL <Growth Author>	Growth Percentile Rank (DCM, 125012)	<CRL Growth Author Information>	Crown Rump Length (LN, 11957-8)
GSD	Gestational Sac Diameter (LN, 11850-5)		
GSD <Gestational Age Author>	Gestational Age (LN, 18185-9)	<GSD Gestational Age Author Information>	Gestational Sac Diameter (LN, 11850-5)
GSD <Gestational Age Author> 2SD	2 Sigma Deviation of Population (DCM, 121417)		Gestational Age (LN, 18185-9) <GSD Gestational Age Author Information> Gestational Sac Diameter (LN, 11850-5)
GSD Mean	Gestational Sac Diameter (LN, 11850-5)	Derivation: Mean (SRT, R-00317)	
GSD <Growth Author>	Growth Percentile Rank (DCM, 125012)	<GSD Growth Author Information>	Gestational Sac Diameter (LN, 11850-5)
Yolk Sac	Yolk Sac Length (LN, 11816-6)		

Label	Code Meaning (Coding Scheme Designator, Code Value)	Modifiers	Measurement References
Yolk Sac Mean	Yolk Sac Length (LN, 11816-6)	Derivation: Mean (SRT, R-00317)	

**11.9.1 CRL Gestational Age Authors**

Author Label	CRL Gestational Age Author Information	Comments
ASUM2000	Equation: CRL, ASUM 2000 (LN, 33090-2)	No associated "2 Sigma Deviation of Population" value.
Hadlock	Equation: CRL, Hadlock 1992 (LN, 11910-7)	
Hansmann	Table: CRL, Hansmann 1986 (LN, 33540-6)	
Rempen	Table: CRL, Rempen 1991 (LN, 33094-4)	
Osaka	Table: CRL, Osaka 1989 (LN, 33093-6)	No associated "2 Sigma Deviation of Population" value.
Robinson	Equation: CRL, Robinson 1975 (LN, 11914-9)	
Tokyo	Table: CRL, Tokyo 1986 (LN, 33096-9)	No associated "2 Sigma Deviation of Population" value.
Lasser	Table: CRL GA Lasser (99ANTARES, CRLGALasser)	
JSUM	Table: CRL GA JSUM (99ANTARES, CRLGAJSUM)	

**11.9.2 CRL Growth Authors**

Author Label	CRL Growth Author Information	Comments
Rempen	Table: CRL by GA, Rempen 1991 (LN, 33160-3)	
ASUM2000	Table: CRL by GA, ASUM 2000 (LN, 33159-5)	
Hadlock	Equation: CRL by GA Hadlock (99ANTARES, GCCRLHadlock)	
Robinson	Equation: CRL by GA Robinson (99ANTARES, GCCRLRobinson)	
Hansmann	Table: CRL by GA Hansmann (99ANTARES, GCCRLHansmann)	
JSUM	Table: CRL by GA JSUM (99ANTARES, GCCRLJSUM)	
Tokyo	Table: CRL by GA Tokyo (99ANTARES, GCCRLTokyo)	
Osaka	Table: CRL by GA Osaka (99ANTARES, GCCRLOsaka)	

**11.9.3 GSD Gestational Age Authors**

Author Label	GSD Gestational Age Author Information	Comments
Rempen	Table: GS, Rempen 1991 (LN, 11929-7)	
Tokyo	Table: GS, Tokyo 1986 (LN, 33108-2)	No associated "2 Sigma Deviation of Population" value.

**11.9.4 GSD Growth Authors**

Author Label	GSD Growth Author Information	Comments
Hellman	Equation: GSD by GA Hellman (99ANTARES, GCGSDHellman)	

Author Label	GSD Growth Author Information	Comments
Tokyo	Table: GSD by GA Tokyo (99ANTARES, GCGSDTokyo)	

### 11.10 Fetal Biophysical Profile

Label	Code Meaning (Coding Scheme Designator, Code Value)	Modifiers	Measurement References
<b>Fetal Biophysical Profile</b>	Container: Biophysical Profile (DCM, 125006)		
Fetal Movements	Gross Body Movement (LN, 11631-9)		
Fetal Breathing	Fetal Breathing (LN, 11632-7)		
Fetal Tone	Fetal Tone (LN, 11635-0)		
Amniotic Fluid	Amniotic Fluid Volume (LN, 11630-1)		
Score	Biophysical Profile Sum Score (LN, 11634-3)		

### 11.11 Pelvis and Uterus

Label	Code Meaning (Coding Scheme Designator, Code Value)	Modifiers	Measurement References
<b>Pelvis and Uterus</b>	Container: Pelvis and Uterus (DCM, 125011)		
Cervix Len	Cervix Length (LN, 11961-0)		
Cervix Len Mean	Cervix Length (LN, 11961-0)	Derivation: Mean (SRT, R-00317)	
Endomet	Endometrium Thickness (LN, 12145-9)		
Endomet Mean	Endometrium Thickness (LN, 12145-9)	Derivation: Mean (SRT, R-00317)	
Uterus	Uterus Distance (99ANTARES, UterusDist)		
Uterus Mean	Uterus Distance (99ANTARES, UterusDist)	Derivation: Mean (SRT, R-00317)	

### 11.12 Fetal and Pelvic Vasculature

The measurements in this table apply to the vessels listed for Fetal Vasculature (section 11.12.1) and Pelvic Vasculature (section 11.12.2).

Label (Section: Measurement)	Code Meaning (Coding Scheme Designator, Code Value)	Modifiers
Doppler: PS	Peak Systolic Velocity (LN, 11726-7)	
Doppler: ED	End Diastolic Velocity (LN, 11653-3)	
Doppler: S/D	Systolic to Diastolic Velocity Ratio (LN, 12144-2)	
Doppler: TAV	Time Averaged Peak Velocity (LN, 11692-1)	
Doppler: PI	Pulsatility Index (LN, 12008-9)	
Doppler: RI	Resistivity Index (LN, 12023-8)	

<b>Label (Section: Measurement)</b>	<b>Code Meaning (Coding Scheme Designator, Code Value)</b>	<b>Modifiers</b>
Doppler: Angle	Doppler Angle Correction (99ANTARES, DopAngleCor)	
Acceleration: Acceleration	Acceleration Index (LN, 20167-3)	
Acceleration: Mean	Acceleration Index (LN, 20167-3)	Derivation: Mean (SRT, R-00317)
Acceleration: V1	Acceleration Velocity 1 (99ANTARES, AccelVel1)	
Acceleration: V2	Acceleration Velocity 2 (99ANTARES, AccelVel2)	
Acceleration: T	Acceleration Time (LN, 20168-1)	
Volume Flow: Volume Flow	Volume Flow (LN, 33878-0)	
Volume Flow: Mean	Volume Flow (LN, 33878-0)	Derivation: Mean (SRT, R-00317)
Volume Flow: A	Volume Flow Area (99ANTARES, VolFArea)	
Volume Flow: D	Volume Flow Distance (99ANTARES, VolFDist)	
Volume Flow: TAMn	Volume Flow Time-Averaged Mean Velocity (99ANTARES, VolFTAvmV)	
Stenosis: %Stenosis [Area]	% Area Reduction (SRT, G-0371)	
Stenosis: Mean [Area]	% Area Reduction (SRT, G-0371)	Derivation: Mean (SRT, R-00317)
Stenosis: A1 Meas 1	Vessel Lumen Cross-Sectional Area (SRT, G-0366)	
Stenosis: A2 Meas 2	Vessel Lumen Cross-Sectional Area (SRT, G-0366)	
Stenosis: %Stenosis [Distance]	% Diameter Reduction (SRT, G-0372)	
Stenosis: Mean [Distance]	% Diameter Reduction (SRT, G-0372)	Derivation: Mean (SRT, R-00317)
Stenosis: D1 Meas 1	Vessel Lumen Diameter (SRT, G-0364)	
Stenosis: D2 Meas 2	Vessel Lumen Diameter (SRT, G-0364)	
2D-Mode: <units>	Distance (99ANTARES, Distance)	
2D-Mode: Mean	Distance (99ANTARES, Distance)	Derivation: Mean (SRT, R-00317)
Velocity: Vel	Velocity (99ANTARES, Velocity)	
Velocity: Mean	Velocity (99ANTARES, Velocity)	Derivation: Mean (SRT, R-00317)
Velocity: Angle	Velocity Angle Correction (99ANTARES, VelAngleCor)	

**11.12.1 Fetal Vasculature**

[Note: Umbilical Artery (Umb A) measurements appear in this section when there are multiple fetuses.]

Label	Code Meaning (Coding Scheme Designator, Code Value)	Modifiers	Measurement References
<b>Fetal Vasculature</b>	Finding Site: Embryonic Vascular Structure (SRT, T-F6800)		
Fetal Ao	Location: Aorta (SRT, T-4200)		
L MCA	Location: Middle Cerebral Artery (SRT, T-45600)	Laterality: Left (SRT, G-A101)	
R MCA	Location: Middle Cerebral Artery (SRT, T-45600)	Laterality: Right (SRT, G-A100)	
Umb A	Location: Umbilical Artery (SRT, T-F1810)		

**11.12.2 Pelvic Vasculature**

[Note: Umbilical Artery (Umb A) measurements appear in this section when there is only one fetus.]

Label	Code Meaning (Coding Scheme Designator, Code Value)	Modifiers	Measurement References
<b>Pelvic Vasculature</b>	Finding Site: Pelvic Vascular Structure (SRT, T-D6007)		
Umb A	Location: Umbilical Artery (SRT, T-F1810)		
L Uterine A	Location: Uterine Artery (SRT, T-46820)	Laterality: Left (SRT, G-A101)	
R Uterine A	Location: Uterine Artery (SRT, T-46820)	Laterality: Right (SRT, G-A100)	
L Ovarian A	Location: Ovarian Artery (SRT, T-46980)	Laterality: Left (SRT, G-A101)	
R Ovarian A	Location: Ovarian Artery (SRT, T-46980)	Laterality: Right (SRT, G-A100)	
Arcuate A	Location: Arcuate Artery (99ANTARES, ArcuateArtery)		

**11.13 Private Section: Ovaries**

Label (Section: Measurement)	Code Meaning (Coding Scheme Designator, Code Value)	Modifiers	Measurement References
<b>Ovaries</b>	Container: Ovaries Section (99ANTARES, Ovaries)		
2D-Mode: L Ovary <units>	Left Ovary Distance (99ANTARES, LOvaryDist)		
2D-Mode: L Ovary Mean	Left Ovary Distance (99ANTARES, LOvaryDist)	Derivation: Mean (SRT, R-00317)	
Volume: L Ovary V	Left Ovary Volume (LN, 12164-0)		
Volume: L Ovary Mean	Left Ovary Volume (LN, 12164-0)	Derivation: Mean (SRT, R-00317)	

Label (Section: Measurement)	Code Meaning (Coding Scheme Designator, Code Value)	Modifiers	Measurement References
Volume: L Ovary D1	Left Ovary Volume: Distance 1 (99ANTARES, LOvaryVolD1)		
Volume: L Ovary D2	Left Ovary Volume: Distance 2 (99ANTARES, LOvaryVolD2)		
Volume: L Ovary D3	Left Ovary Volume: Distance 3 (99ANTARES, LOvaryVolD3)		
2D-Mode: R Ovary <units>	Right Ovary Distance (99ANTARES, ROvaryDist)		
2D-Mode: R Ovary Mean	Right Ovary Distance (99ANTARES, ROvaryDist)	Derivation: Mean (SRT, R-00317)	
Volume: R Ovary V	Right Ovary Volume (LN, 12165-7)		
Volume: R Ovary Mean	Right Ovary Volume (LN, 12165-7)	Derivation: Mean (SRT, R-00317)	
Volume: R Ovary D1	Right Ovary Volume: Distance 1 (99ANTARES, ROvaryVolD1)		
Volume: R Ovary D2	Right Ovary Volume: Distance 2 (99ANTARES, ROvaryVolD2)		
Volume: R Ovary D3	Right Ovary Volume: Distance 3 (99ANTARES, ROvaryVolD3)		

**11.14 Private Sections: Left Follicles and Right Follicles**

Label	Code Meaning (Coding Scheme Designator, Code Value)	Modifiers	Measurement References
<b>Follicles</b>	Container: Follicles Section (99ANTARES, Follicles)	Laterality: Left (SRT, G-A101) or Laterality: Right (SRT, G-A100)	
<L or R> Follicle 1	Follicle 1 Distance (99ANTARES, Follicle1Dist)		
<L or R> Follicle 1 Mean	Follicle 1 Distance (99ANTARES, Follicle1Dist)	Derivation: Mean (SRT, R-00317)	
<L or R> Follicle 2	Follicle 2 Distance (99ANTARES, Follicle2Dist)		
<L or R> Follicle 2 Mean	Follicle 2 Distance (99ANTARES, Follicle2Dist)	Derivation: Mean (SRT, R-00317)	
<L or R> Follicle 3	Follicle 3 Distance (99ANTARES, Follicle3Dist)		
<L or R> Follicle 3 Mean	Follicle 3 Distance (99ANTARES, Follicle3Dist)	Derivation: Mean (SRT, R-00317)	
<L or R> Follicle 4	Follicle 4 Distance (99ANTARES, Follicle4Dist)		
<L or R> Follicle 4 Mean	Follicle 4 Distance (99ANTARES, Follicle4Dist)	Derivation: Mean (SRT, R-00317)	
<L or R> Follicle 5	Follicle 5 Distance (99ANTARES, Follicle5Dist)		
<L or R> Follicle 5 Mean	Follicle 5 Distance (99ANTARES, Follicle5Dist)	Derivation: Mean (SRT, R-00317)	
<L or R> Follicle 6	Follicle 6 Distance (99ANTARES, Follicle6Dist)		
<L or R> Follicle 6 Mean	Follicle 6 Distance (99ANTARES, Follicle6Dist)	Derivation: Mean (SRT, R-00317)	

**11.15 Private Sections: Left Cysts and Right Cysts**

Label	Code Meaning (Coding Scheme Designator, Code Value)	Modifiers	Measurement References
<b>Cysts</b>	Container: Cysts Section (99ANTARES, Cysts)	Laterality: Left (SRT, G-A101) or Laterality: Right (SRT, G-A100)	
<L or R> Cyst 1	Cyst 1 Distance (99ANTARES, Cyst1Dist)		
<L or R> Cyst 1 Mean	Cyst 1 Distance (99ANTARES, Cyst1Dist)	Derivation: Mean (SRT, R-00317)	
<L or R> Cyst 2	Cyst 2 Distance (99ANTARES, Cyst2Dist)		
<L or R> Cyst 2 Mean	Cyst 2 Distance (99ANTARES, Cyst2Dist)	Derivation: Mean (SRT, R-00317)	
<L or R> Cyst 3	Cyst 3 Distance (99ANTARES, Cyst3Dist)		
<L or R> Cyst 3 Mean	Cyst 3 Distance (99ANTARES, Cyst3Dist)	Derivation: Mean (SRT, R-00317)	
<L or R> Cyst 4	Cyst 4 Distance (99ANTARES, Cyst4Dist)		
<L or R> Cyst 4 Mean	Cyst 4 Distance (99ANTARES, Cyst4Dist)	Derivation: Mean (SRT, R-00317)	
<L or R> Cyst 5	Cyst 5 Distance (99ANTARES, Cyst5Dist)		
<L or R> Cyst 5 Mean	Cyst 5 Distance (99ANTARES, Cyst5Dist)	Derivation: Mean (SRT, R-00317)	
<L or R> Cyst 6	Cyst 6 Distance (99ANTARES, Cyst6Dist)		
<L or R> Cyst 6 Mean	Cyst 6 Distance (99ANTARES, Cyst6Dist)	Derivation: Mean (SRT, R-00317)	

**11.16 Private Section: Bladder**

Label	Code Meaning (Coding Scheme Designator, Code Value)	Modifiers	Measurement References
<b>Bladder</b>	Container: Bladder Section (99ANTARES, Bladder)		
Micturated	Micturated Volume (99ANTARES, MicturatedVol)		
PreVoid Bld V	Pre-Void Volume (99ANTARES, PreVoidVol)		
PreVoid Bld Mean	Pre-Void Volume (99ANTARES, PreVoidVol)	Derivation: Mean (SRT, R-00317)	
PreVoid Bld D1	Pre-Void Volume: Distance 1 (99ANTARES, PreVoidVolD1)		
PreVoid Bld D2	Pre-Void Volume: Distance 2 (99ANTARES, PreVoidVolD2)		
PreVoid Bld D3	Pre-Void Volume: Distance 3 (99ANTARES, PreVoidVolD3)		
PostVoid Bld V	Post-Void Volume (99ANTARES, PostVoidVol)		
PostVoid Bld Mean	Post-Void Volume (99ANTARES, PostVoidVol)	Derivation: Mean (SRT, R-00317)	

Label	Code Meaning (Coding Scheme Designator, Code Value)	Modifiers	Measurement References
PostVoid Bld D1	Post-Void Volume: Distance 1 (99ANTARES, PostVoidVolD1)		
PostVoid Bld D2	Post-Void Volume: Distance 2 (99ANTARES, PostVoidVolD2)		
PostVoid Bld D3	Post-Void Volume: Distance 3 (99ANTARES, PostVoidVolD3)		

**11.17 Private Section: Maternal Kidney**

Label (Section: Measurement)	Code Meaning (Coding Scheme Designator, Code Value)	Modifiers	Measurement References
<b>Maternal Kidney</b>	Container: Maternal Kidney (99ANTARES, MKidney)		
2D-Mode: L Mat Kidney <units>	Left Maternal Kidney Distance (99ANTARES, LMKidneyDist)		
2D-Mode: L Mat Kidney Mean	Left Maternal Kidney Distance (99ANTARES, LMKidneyDist)	Derivation: Mean (SRT, R-00317)	
Volume: L Mat Kidney V	Left Maternal Kidney Volume (99ANTARES, LMKidneyVol)		
Volume: L Mat Kidney Mean	Left Maternal Kidney Volume (99ANTARES, LMKidneyVol)	Derivation: Mean (SRT, R-00317)	
Volume: L Mat Kidney D1	Left Maternal Kidney Volume: Distance 1 (99ANTARES, LMKidneyVolD1)		
Volume: L Mat Kidney D2	Left Maternal Kidney Volume: Distance 2 (99ANTARES, LMKidneyVolD2)		
Volume: L Mat Kidney D3	Left Maternal Kidney Volume: Distance 3 (99ANTARES, LMKidneyVolD3)		
2D: R Mat Kidney <units>	Right Maternal Kidney Distance (99ANTARES, RMKidneyDist)		
2D: R Mat Kidney Mean	Right Maternal Kidney Distance (99ANTARES, RMKidneyDist)	Derivation: Mean (SRT, R-00317)	
Volume: R Mat Kidney V	Right Maternal Kidney Volume (99ANTARES, RMKidneyVol)		
Volume: R Mat Kidney Mean	Right Maternal Kidney Volume (99ANTARES, RMKidneyVol)	Derivation: Mean (SRT, R-00317)	

Label (Section: Measurement)	Code Meaning (Coding Scheme Designator, Code Value)	Modifiers	Measurement References
Volume: R Mat Kidney D1	Right Maternal Kidney Volume: Distance 1 (99ANTARES, RMKidneyVolD1)		
Volume: R Mat Kidney D2	Right Maternal Kidney Volume: Distance 2 (99ANTARES, RMKidneyVolD2)		
Volume: R Mat Kidney D3	Right Maternal Kidney Volume: Distance 3 (99ANTARES, RMKidneyVolD3)		

## 12.0 Appendix B: Vascular Structured Report Measurements

This appendix lists the DICOM Structured Report (SR) mappings used in the Vascular Structured Reports of Antares SR files, version 5.0.

The mappings are organized in a manner similar to the DICOM SR Templates as described in PS 3.16-2004 of the DICOM Standard. The “Label” column identifies the on-screen report label associated with a measurement. All private code values use the Coding Scheme Designator “99ANTARES”.

The Vascular Report mappings follow the DICOM SR Template TID 5100: Vascular Ultrasound Report. Mixed Carotid Ratios, Kidney, Ureter, Bladder, “Liver, Gall Bladder, Pancreas”, and Spleen are private sections in this release.

The measurements in the table below apply to the vessels listed in this Appendix. The %Stenosis and %Stenosis-related measurements are not available for veins. “Mean” values are not present in the SR for the following vessels because these vessels are available as labeled measurements in multiple exam headings: Common Carotid Artery, Vertebral Artery, Innominate Artery, Abdominal Aorta, Inferior Vena Cava, Renal Artery.

Notation:

- <units> means that the Distance units will be displayed on the report
- [ ... ] is additional information about the label

Label (Section: Measurement)	Code Meaning (Coding Scheme Designator, Code Value)	Modifiers
Doppler: PS	Peak Systolic Velocity (LN, 11726-7)	
Doppler: ED	End Diastolic Velocity (LN, 11653-3)	
Doppler: S/D	Systolic to Diastolic Velocity Ratio (LN, 12144-2)	
Doppler: TAV	Time Averaged Peak Velocity (LN, 11692-1)	
Doppler: TAV	Doppler Time Averaged Velocity (99ANTARES, DopTAV)	
Doppler: PI	Pulsatility Index (LN, 12008-9)	
Doppler: RI	Resistivity Index (LN, 12023-8)	
Doppler: Angle	Doppler Angle Correction (99ANTARES, DopAngleCor)	
Acceleration: Acceleration	Acceleration Index (LN, 20167-3)	
Acceleration: Mean	Acceleration Index (LN, 20167-3)	Derivation: Mean (SRT, R-00317)
Acceleration: V1	Acceleration Velocity 1 (99ANTARES, AccelVel1)	
Acceleration: V2	Acceleration Velocity 2 (99ANTARES, AccelVel2)	

Label (Section: Measurement)	Code Meaning (Coding Scheme Designator, Code Value)	Modifiers
Acceleration: T	Acceleration Time (LN, 20168-1)	
Volume Flow: Volume Flow	Volume Flow (LN, 33878-0)	
Volume Flow: Mean	Volume Flow (LN, 33878-0)	Derivation: Mean (SRT, R-00317)
Volume Flow: A	Volume Flow Area (99ANTARES, VolFArea)	
Volume Flow: D	Volume Flow Distance (99ANTARES, VolFDist)	
Volume Flow: TAMn	Volume Flow Time-Averaged Mean Velocity (99ANTARES, VolFTAVmV)	
Stenosis: %Stenosis [Area]	% Area Reduction (SRT, G-0371)	
Stenosis: Mean [Area]	% Area Reduction (SRT, G-0371)	Derivation: Mean (SRT, R-00317)
Stenosis: A1 Meas 1	Vessel Lumen Cross-Sectional Area (SRT, G-0366)	
Stenosis: A2 Meas 2	Vessel Lumen Cross-Sectional Area (SRT, G-0366)	
Stenosis: %Stenosis [Distance]	% Diameter Reduction (SRT, G-0372)	
Stenosis: Mean [Distance]	% Diameter Reduction (SRT, G-0372)	Derivation: Mean (SRT, R-00317)
Stenosis: D1 Meas 1	Vessel Lumen Diameter (SRT, G-0364)	
Stenosis: D2 Meas 2	Vessel Lumen Diameter (SRT, G-0364)	
2D-Mode: <units>	Distance (99ANTARES, Distance)	
2D-Mode: Mean	Distance (99ANTARES, Distance)	Derivation: Mean (SRT, R-00317)
Velocity: Vel	Velocity (99ANTARES, Velocity)	
Velocity: Mean	Velocity (99ANTARES, Velocity)	Derivation: Mean (SRT, R-00317)
Velocity: Angle	Velocity Angle Correction (99ANTARES, VelAngleCor)	

**TID5100: Vascular Ultrasound Report**

**12.1 Patient Characteristics**

Label	Code Meaning (Coding Scheme Designator, Code Value)	Modifiers
<b>Patient Characteristics</b>	Container: Patient Characteristics (DCM, 121118)	
Age	Subject Age (DCM, 121033)	
Sex	Subject Sex (DCM, 121032)	

Label	Code Meaning (Coding Scheme Designator, Code Value)	Modifiers
HR	Heart Rate (LN, 8867-4)	
BP	Systolic Blood Pressure (SRT, F-008EC)	
	Diastolic Blood Pressure (SRT, F-008ED)	

## 12.2 Procedure Summary

Label	Code Meaning (Coding Scheme Designator, Code Value)	Modifiers
<b>Procedure Summary</b>	Container: Summary (DCM, 121111)	
Indication	Comment (DCM, 121106)	
Additional Info.	Comment (DCM, 121106)	
Comments	Comment (DCM, 121106)	

## 12.3 Blood Vessels of Head (Left Intracranial Cerebral Vessels)

Label	Code Meaning (Coding Scheme Designator, Code Value)	Modifiers
<b>Blood Vessel of Head (Intracranial Cerebral Vessels)</b>	Finding Site: Blood Vessel of Head (SRT, T-40501)	Laterality: Left (SRT, G-A101)
L MCA/L ICA-Siphon	MCA/ICA Siphon (99ANTARES, McaIcaSRatio)	
L ICA-Siphon [Label:TCD]	Location: Carotid Siphon (SRT, T-45308)	Laterality: Left (SRT, G-A101)
L MCA [Label:TCD]	Location: Middle Cerebral Artery (SRT, T-45600)	Laterality: Left (SRT, G-A101)
L PCA [Label:TCD]	Location: Posterior Cerebral Artery (SRT, T-45900)	Laterality: Left (SRT, G-A101)
L ACA-A1 [Label:TCD]	Location: Anterior Cerebral Artery A1 (99ANTARES, AntCerebAA1)	Laterality: Left (SRT, G-A101)
L ACA-A2 [Label:TCD]	Location: Anterior Cerebral Artery A2 (99ANTARES, AntCerebAA2)	Laterality: Left (SRT, G-A101)
L PCA-P1 [Label:TCD]	Location: Posterior Cerebral Artery P1 (99ANTARES, PostCerebAP1)	Laterality: Left (SRT, G-A101)
L PCA-P2 [Label:TCD]	Location: Posterior Cerebral Artery P2 (99ANTARES, PostCerebAP2)	Laterality: Left (SRT, G-A101)

## 12.4 Blood Vessel of Head (Right Intracranial Cerebral Vessels)

Label	Code Meaning (Coding Scheme Designator, Code Value)	Modifiers
<b>Blood Vessel of Head (Intracranial Cerebral Vessels)</b>	Finding Site: Blood Vessel of Head (SRT, T-40501)	Laterality: Right (SRT, G-A100)
R MCA/R ICA-Siphon	MCA/ICA Siphon (99ANTARES, McaIcaSRatio)	

Label	Code Meaning (Coding Scheme Designator, Code Value)	Modifiers
R ICA-Siphon [Label:TCD]	Location: Carotid Siphon (SRT, T-45308)	Laterality: Right (SRT, G-A100)
R MCA [Label:TCD]	Location: Middle Cerebral Artery (SRT, T-45600)	Laterality: Right (SRT, G-A100)
R PCA [Label:TCD]	Location: Posterior Cerebral Artery (SRT, T-45900)	Laterality: Right (SRT, G-A100)
R ACA-A1 [Label: TCD]	Location: Anterior Cerebral Artery A1 (99ANTARES, AntCerebAA1)	Laterality: Right (SRT, G-A100)
R ACA-A2 [Label: TCD]	Location: Anterior Cerebral Artery A2 (99ANTARES, AntCerebAA2)	Laterality: Right (SRT, G-A100)
R PCA-P1 [Label: TCD]	Location: Posterior Cerebral Artery P1 (99ANTARES, PostCerebAP1)	Laterality: Right (SRT, G-A100)
R PCA-P2 [Label: TCD]	Location: Posterior Cerebral Artery P2 (99ANTARES, PostCerebAP2)	Laterality: Right (SRT, G-A100)

### 12.5 Blood Vessel of Head (Unilateral Intracranial Cerebral Vessels)

Label	Code Meaning (Coding Scheme Designator, Code Value)	Modifiers
<b>Blood Vessel of Head (Intracranial Cerebral Vessels)</b>	Finding Site: Blood Vessel of Head (SRT, T-40501)	Laterality: Unilateral (SRT, G-A103)
Basilar A [Label: TCD]	Location: Basilar Artery (SRT, T-45800)	Laterality: Unilateral (SRT, G-A103)
ACoA [Label: TCD]	Location: Anterior Communicating Artery (SRT, T-45530)	Laterality: Unilateral (SRT, G-A103)
PCoA [Label: TCD]	Location: Posterior Communicating Artery (SRT, T-45320)	Laterality: Unilateral (SRT, G-A103)

### 12.6 Artery of Neck (Left Extracranial Arteries, Carotid Ratios)

Label	Code Meaning (Coding Scheme Designator, Code Value)	Modifiers
<b>Artery of Neck (Extracranial Arteries, Carotid Ratios)</b>	Finding Site: Artery of Neck (SRT, T-45005)	Laterality: Left (SRT, G-A101)
L <Prox, Mid, or Dist> ICA / L <Prox, Mid, or Dist> CCA [User selected CV Velocity Ratios]	ICA/CCA velocity ratio (LN, 33868-1)	
L <Prox, Mid, or Dist> ICA / L <Prox, Mid, or Dist> CCA ED [User selected CV ICA/CCA Ratios]	End Diastole: ICA/CCA (99ANTARES, EDIcaCCARatio)	
L <Prox, Mid, or Dist> ICA / L <Prox, Mid, or Dist> CCA PS [User selected CV ICA/CCA Ratios]	Peak Systole: ICA/CCA (99ANTARES, PSIcaCCARatio)	

Label	Code Meaning (Coding Scheme Designator, Code Value)	Modifiers
L CCA [Labels: CV, PV-Art]	Location: Common Carotid Artery (SRT, T-45100)	Laterality: Left (SRT, G-A101)
L P CCA		Topographical Modifier: Proximal (SRT, G-A118)
L M CCA		Topographical Modifier: Mid-longitudinal (SRT, G-A188)
L D CCA		Topographical Modifier: Distal (SRT, G-A119)
L ECA [Label: CV]	Location: External Carotid Artery (SRT, T-45200)	Laterality: Left (SRT, G-A101)
L P ECA		Topographical Modifier: Proximal (SRT, G-A118)
L M ECA		Topographical Modifier: Mid-longitudinal (SRT, G-A188)
L D ECA		Topographical Modifier: Distal (SRT, G-A119)
L ICA [Label: CV]	Location: Internal Carotid Artery (SRT, T-45300)	Laterality: Left (SRT, G-A101)
L P ICA		Topographical Modifier: Proximal (SRT, G-A118)
L M ICA		Topographical Modifier: Mid-longitudinal (SRT, G-A188)
L D ICA		Topographical Modifier: Distal (SRT, G-A119)
L Subclav A [Label: CV]	Location: Subclavian Artery (SRT, T-46100)	Laterality: Left (SRT, G-A101)
L P Subclav A		Topographical Modifier: Proximal (SRT, G-A118)
L M Subclav A		Topographical Modifier: Mid-longitudinal (SRT, G-A188)
L D Subclav A		Topographical Modifier: Distal (SRT, G-A119)
L Vert A [Labels: CV, PV-Art, TCD]	Location: Vertebral Artery (SRT, T-45700)	Laterality: Left (SRT, G-A101)
L Vert A		
L P Vert A		Topographical Modifier: Proximal (SRT, G-A118)
L M Vert A		Topographical Modifier: Mid-longitudinal (SRT, G-A188)
L D Vert A		Topographical Modifier: Distal (SRT, G-A119)

### 12.7 Artery of Neck (Right Extracranial Arteries, Carotid Ratios)

Label	Code Meaning (Coding Scheme Designator, Code Value)	Modifiers
<b>Artery of Neck (Extracranial Arteries, Carotid Ratios)</b>	Finding Site: Artery of Neck (SRT, T-45005)	Laterality: Right (SRT, G-A100)
R <Prox, Mid, or Dist> ICA / R <Prox, Mid, or Dist> CCA [User selected CV Velocity Ratios]	ICA/CCA velocity ratio (LN, 33868-1)	
R <Prox, Mid, or Dist> ICA / R <Prox, Mid, or Dist> CCA ED [User selected CV ICA/CCA Ratios]	End Diastole: ICA/CCA (99ANTARES, EDIcaCCARatio)	

Label	Code Meaning (Coding Scheme Designator, Code Value)	Modifiers
R <Prox, Mid, or Dist> ICA / R <Prox, Mid, or Dist> CCA PS [User selected CV ICA/CCA Ratios]	Peak Systole: ICA/CCA (99ANTARES, PSIcaCCARatio)	
R CCA [Labels: CV, PV-Art]	Location: Common Carotid Artery (SRT, T-45100)	Laterality: Right (SRT, G-A100)
R P CCA		Topographical Modifier: Proximal (SRT, G-A118)
R M CCA		Topographical Modifier: Mid-longitudinal (SRT, G-A188)
R D CCA		Topographical Modifier: Distal (SRT, G-A119)
R ECA [Label: CV]	Location: External Carotid Artery (SRT, T-45200)	Laterality: Right (SRT, G-A100)
R P ECA		Topographical Modifier: Proximal (SRT, G-A118)
R M ECA		Topographical Modifier: Mid-longitudinal (SRT, G-A188)
R D ECA		Topographical Modifier: Distal (SRT, G-A119)
R ICA [Label: CV]	Location: Internal Carotid Artery (SRT, T-45300)	Laterality: Right (SRT, G-A100)
R P ICA		Topographical Modifier: Proximal (SRT, G-A118)
R M ICA		Topographical Modifier: Mid-longitudinal (SRT, G-A188)
R D ICA		Topographical Modifier: Distal (SRT, G-A119)
R Subclav A [Label: CV]	Location: Subclavian Artery (SRT, T-46100)	Laterality: Right (SRT, G-A100)
R P Subclav A		Topographical Modifier: Proximal (SRT, G-A118)
R M Subclav A		Topographical Modifier: Mid-longitudinal (SRT, G-A188)
R D Subclav A		Topographical Modifier: Distal (SRT, G-A119)
R Vert A [Labels: CV, PV-Art, TCD]	Location: Vertebral Artery (SRT, T-45700)	Laterality: Right (SRT, G-A100)
R Vert A		
R P Vert A		Topographical Modifier: Proximal (SRT, G-A118)
R M Vert A		Topographical Modifier: Mid-longitudinal (SRT, G-A188)
R D Vert A		Topographical Modifier: Distal (SRT, G-A119)

**12.8 Artery of Lower Extremity (Left Side)**

Label	Code Meaning (Coding Scheme Designator, Code Value)	Modifiers
<b>Artery of Lower Extremity</b>	Finding Site: Artery of Lower Extremity (SRT, T-47040)	Laterality: Left (SRT, G-A101)
L CIA [Label: PV-Art] L Iliac A [Label: Abd]	Location: Common Iliac Artery (SRT, T-46710)	Laterality: Left (SRT, G-A101)
L P CIA L P Iliac A		Topographical Modifier: Proximal (SRT, G-A118)
L M CIA L M Iliac A		Topographical Modifier: Mid-longitudinal (SRT, G-A188)

Label	Code Meaning (Coding Scheme Designator, Code Value)	Modifiers
L D CIA L D Iliac A		Topographical Modifier: Distal (SRT, G-A119)
L Ant Tib A [Label: PV-Art]	Location: Anterior Tibial Artery (SRT, T-47700)	Laterality: Left (SRT, G-A101)
L P Ant Tib A		Topographical Modifier: Proximal (SRT, G-A118)
L M Ant Tib A		Topographical Modifier: Mid-longitudinal (SRT, G-A188)
L D Ant Tib A		Topographical Modifier: Distal (SRT, G-A119)
L CFA [Label: PV-Art]	Location: Common Femoral Artery (SRT, T-47400)	Laterality: Left (SRT, G-A101)
L P CFA		Topographical Modifier: Proximal (SRT, G-A118)
L M CFA		Topographical Modifier: Mid-longitudinal (SRT, G-A188)
L D CFA		Topographical Modifier: Distal (SRT, G-A119)
L DPA [Label: PV-Art]	Location: Dorsalis Pedis Artery (SRT, T-47741)	Laterality: Left (SRT, G-A101)
L P DPA		Topographical Modifier: Proximal (SRT, G-A118)
L M DPA		Topographical Modifier: Mid-longitudinal (SRT, G-A188)
L D DPA		Topographical Modifier: Distal (SRT, G-A119)
L EIA [Label: PV-Art]	Location: External Iliac Artery (SRT, T-46910)	Laterality: Left (SRT, G-A101)
L P EIA		Topographical Modifier: Proximal (SRT, G-A118)
L M EIA		Topographical Modifier: Mid-longitudinal (SRT, G-A188)
L D EIA		Topographical Modifier: Distal (SRT, G-A119)
L IIA [Label: PV-Art]	Location: Internal Iliac Artery (SRT, T-46740)	Laterality: Left (SRT, G-A101)
L P IIA		Topographical Modifier: Proximal (SRT, G-A118)
L M IIA		Topographical Modifier: Mid-longitudinal (SRT, G-A188)
L D IIA		Topographical Modifier: Distal (SRT, G-A119)
L Peroneal A [Label: PV-Art]	Location: Peroneal Artery (SRT, T-47630)	Laterality: Left (SRT, G-A101)
L P Peroneal A		Topographical Modifier: Proximal (SRT, G-A118)
L M Peroneal A		Topographical Modifier: Mid-longitudinal (SRT, G-A188)
L D Peroneal A		Topographical Modifier: Distal (SRT, G-A119)
L Pop A [Label: PV-Art]	Location: Popliteal Artery (SRT, T-47500)	Laterality: Left (SRT, G-A101)
L P Pop A		Topographical Modifier: Proximal (SRT, G-A118)
L M Pop A		Topographical Modifier: Mid-longitudinal (SRT, G-A188)
L D Pop A		Topographical Modifier: Distal (SRT, G-A119)
L Post Tib A [Label: PV-Art]	Location: Posterior Tibial Artery (SRT, T-47600)	Laterality: Left (SRT, G-A101)
L P Post Tib A		Topographical Modifier: Proximal (SRT, G-A118)
L M Post Tib A		Topographical Modifier: Mid-longitudinal (SRT, G-A188)
L D Post Tib A		Topographical Modifier: Distal (SRT, G-A119)

Label	Code Meaning (Coding Scheme Designator, Code Value)	Modifiers
L PFA [Label: PV-Art]	Location: Profunda Femoris Artery (SRT, T-47440)	Laterality: Left (SRT, G-A101)
L P PFA		Topographical Modifier: Proximal (SRT, G-A118)
L M PFA		Topographical Modifier: Mid-longitudinal (SRT, G-A188)
L D PFA		Topographical Modifier: Distal (SRT, G-A119)
L SFA [Label: PV-Art]	Location: Superficial Femoral Artery (SRT, T-47403)	Laterality: Left (SRT, G-A101)
L P SFA		Topographical Modifier: Proximal (SRT, G-A118)
L M SFA		Topographical Modifier: Mid-longitudinal (SRT, G-A188)
L D SFA		Topographical Modifier: Distal (SRT, G-A119)
L T-P Trunk A [Label: PV-Art]	Location: Tibial-Peroneal Trunk Artery (99ANTARES, TibPeronTrnkA)	Laterality: Left (SRT, G-A101)
L P T-P Trunk A		Topographical Modifier: Proximal (SRT, G-A118)
L M T-P Trunk A		Topographical Modifier: Mid-longitudinal (SRT, G-A188)
L D T-P Trunk A		Topographical Modifier: Distal (SRT, G-A119)

## 12.9 Artery of Lower Extremity (Right Side)

Label	Code Meaning (Coding Scheme Designator, Code Value)	Modifiers
<b>Artery of Lower Extremity</b>	Finding Site: Artery of Lower Extremity (SRT, T-47040)	Laterality: Right (SRT, G-A100)
R CIA [Label: PV-Art, Abd]	Location: Common Iliac Artery (SRT, T-46710)	Laterality: Right (SRT, G-A100)
R P CIA		Topographical Modifier: Proximal (SRT, G-A118)
R M CIA		Topographical Modifier: Mid-longitudinal (SRT, G-A188)
R D CIA		Topographical Modifier: Distal (SRT, G-A119)
R Ant Tib A [Label: PV-Art]	Location: Anterior Tibial Artery (SRT, T-47700)	Laterality: Right (SRT, G-A100)
R P Ant Tib A		Topographical Modifier: Proximal (SRT, G-A118)
R M Ant Tib A		Topographical Modifier: Mid-longitudinal (SRT, G-A188)
R D Ant Tib A		Topographical Modifier: Distal (SRT, G-A119)
R CFA [Label: PV-Art]	Location: Common Femoral Artery (SRT, T-47400)	Laterality: Right (SRT, G-A100)
R P CFA		Topographical Modifier: Proximal (SRT, G-A118)
R M CFA		Topographical Modifier: Mid-longitudinal (SRT, G-A188)
R D CFA		Topographical Modifier: Distal (SRT, G-A119)

Label	Code Meaning (Coding Scheme Designator, Code Value)	Modifiers
R DPA [Label: PV-Art]	Location: Dorsalis Pedis Artery (SRT, T-47741)	Laterality: Right (SRT, G-A100)
R P DPA		Topographical Modifier: Proximal (SRT, G-A118)
R M DPA		Topographical Modifier: Mid-longitudinal (SRT, G-A188)
R D DPA		Topographical Modifier: Distal (SRT, G-A119)
R EIA [Label: PV-Art]	Location: External Iliac Artery (SRT, T-46910)	Laterality: Right (SRT, G-A100)
R P EIA		Topographical Modifier: Proximal (SRT, G-A118)
R M EIA		Topographical Modifier: Mid-longitudinal (SRT, G-A188)
R D EIA		Topographical Modifier: Distal (SRT, G-A119)
R IIA [Label: PV-Art]	Location: Internal Iliac Artery (SRT, T-46740)	Laterality: Right (SRT, G-A100)
R P IIA		Topographical Modifier: Proximal (SRT, G-A118)
R M IIA		Topographical Modifier: Mid-longitudinal (SRT, G-A188)
R D IIA		Topographical Modifier: Distal (SRT, G-A119)
R Peroneal A [Label: PV-Art]	Location: Peroneal Artery (SRT, T-47630)	Laterality: Right (SRT, G-A100)
R P Peroneal A		Topographical Modifier: Proximal (SRT, G-A118)
R M Peroneal A		Topographical Modifier: Mid-longitudinal (SRT, G-A188)
R D Peroneal A		Topographical Modifier: Distal (SRT, G-A119)
R Pop A [Label: PV-Art]	Location: Popliteal Artery (SRT, T-47500)	Laterality: Right (SRT, G-A100)
R P Pop A		Topographical Modifier: Proximal (SRT, G-A118)
R M Pop A		Topographical Modifier: Mid-longitudinal (SRT, G-A188)
R D Pop A		Topographical Modifier: Distal (SRT, G-A119)
R Post Tib A [Label: PV-Art]	Location: Posterior Tibial Artery (SRT, T-47600)	Laterality: Right (SRT, G-A100)
R P Post Tib A		Topographical Modifier: Proximal (SRT, G-A118)
R M Post Tib A		Topographical Modifier: Mid-longitudinal (SRT, G-A188)
R D Post Tib A		Topographical Modifier: Distal (SRT, G-A119)
R PFA [Label: PV-Art]	Location: Profunda Femoris Artery (SRT, T-47440)	Laterality: Right (SRT, G-A100)
R P PFA		Topographical Modifier: Proximal (SRT, G-A118)
R M PFA		Topographical Modifier: Mid-longitudinal (SRT, G-A188)
R D PFA		Topographical Modifier: Distal (SRT, G-A119)
R SFA [Label: PV-Art]	Location: Superficial Femoral Artery (SRT, T-47403)	Laterality: Right (SRT, G-A100)
R P SFA		Topographical Modifier: Proximal (SRT, G-A118)
R M SFA		Topographical Modifier: Mid-longitudinal (SRT, G-A188)
R D SFA		Topographical Modifier: Distal (SRT, G-A119)

Label	Code Meaning (Coding Scheme Designator, Code Value)	Modifiers
R T-P Trunk A [Label: PV-Art]	Location: Tibial-Peroneal Trunk Artery (99ANTARES, TibPeronTrnkA)	Laterality: Right (SRT, G-A100)
R P T-P Trunk A		Topographical Modifier: Proximal (SRT, G-A118)
R M T-P Trunk A		Topographical Modifier: Mid-longitudinal (SRT, G-A188)
R D T-P Trunk A		Topographical Modifier: Distal (SRT, G-A119)

**12.10 Artery of Upper Extremity (Left Side)**

Label	Code Meaning (Coding Scheme Designator, Code Value)	Modifiers
<b>Artery of Upper Extremity</b>	Finding Site: Artery of Upper Extremity (SRT, T-47020)	Laterality: Left (SRT, G-A101)
L Axillary A [Label: PV-Art]	Location: Axillary Artery (SRT, T-47100)	Laterality: Left (SRT, G-A101)
L P Axillary A		Topographical Modifier: Proximal (SRT, G-A118)
L M Axillary A		Topographical Modifier: Mid-longitudinal (SRT, G-A188)
L D Axillary A		Topographical Modifier: Distal (SRT, G-A119)
L Brachial A [Label: PV-Art]	Location: Brachial Artery (SRT, T-47160)	Laterality: Left (SRT, G-A101)
L P Brachial A		Topographical Modifier: Proximal (SRT, G-A118)
L M Brachial A		Topographical Modifier: Mid-longitudinal (SRT, G-A188)
L D Brachial A		Topographical Modifier: Distal (SRT, G-A119)
L Deep Brachial A [Label: PV-Art]	Location: Deep Brachial Artery (99Antares, DeepBrachialA)	Laterality: Left (SRT, G-A101)
L P Deep Brachial A		Topographical Modifier: Proximal (SRT, G-A118)
L M Deep Brachial A		Topographical Modifier: Mid-longitudinal (SRT, G-A188)
L D Deep Brachial A		Topographical Modifier: Distal (SRT, G-A119)
L Radial A [Label: PV-Art]	Location: Radial Artery (SRT, T-47300)	Laterality: Left (SRT, G-A101)
L P Radial A		Topographical Modifier: Proximal (SRT, G-A118)
L M Radial A		Topographical Modifier: Mid-longitudinal (SRT, G-A188)
L D Radial A		Topographical Modifier: Distal (SRT, G-A119)
L Subclav A [Label: PV-Art]	Location: Subclavian Artery (SRT, T-46100)	Laterality: Left (SRT, G-A101)
L P Subclav A		Topographical Modifier: Proximal (SRT, G-A118)
L M Subclav A		Topographical Modifier: Mid-longitudinal (SRT, G-A188)
L D Subclav A		Topographical Modifier: Distal (SRT, G-A119)
L Ulnar A [Label: PV-Art]	Location: Ulnar Artery (SRT, T-47200)	Laterality: Left (SRT, G-A101)
L P Ulnar A		Topographical Modifier: Proximal (SRT, G-A118)
L M Ulnar A		Topographical Modifier: Mid-longitudinal (SRT, G-A188)
L D Ulnar A		Topographical Modifier: Distal (SRT, G-A119)

**12.11 Artery of Upper Extremity (Right Side)**

Label	Code Meaning (Coding Scheme Designator, Code Value)	Modifiers
<b>Artery of Upper Extremity</b>	Finding Site: Artery of Upper Extremity (SRT, T-47020)	Laterality: Right (SRT, G-A100)
R Axillary A [Label: PV-Art]	Location: Axillary Artery (SRT, T-47100)	Laterality: Right (SRT, G-A100)
R P Axillary A		Topographical Modifier: Proximal (SRT, G-A118)
R M Axillary A		Topographical Modifier: Mid-longitudinal (SRT, G-A188)
R D Axillary A		Topographical Modifier: Distal (SRT, G-A119)
R Brachial A [Label: PV-Art]	Location: Brachial Artery (SRT, T-47160)	Laterality: Right (SRT, G-A100)
R P Brachial A		Topographical Modifier: Proximal (SRT, G-A118)
R M Brachial A		Topographical Modifier: Mid-longitudinal (SRT, G-A188)
R D Brachial A		Topographical Modifier: Distal (SRT, G-A119)
R Deep Brachial A [Label: PV-Art]	Location: Brachial Artery (99Antares, DeepBrachialA)	Laterality: Right (SRT, G-A100)
R P Brachial A		Topographical Modifier: Proximal (SRT, G-A118)
R M Brachial A		Topographical Modifier: Mid-longitudinal (SRT, G-A188)
R D Brachial A		Topographical Modifier: Distal (SRT, G-A119)
Innom A [Labels: CV, PV-Art]	Location: Innominate Artery (SRT, T-46010)	Laterality: Right (SRT, G-A100)
P Innom A		Topographical Modifier: Proximal (SRT, G-A118)
M Innom A		Topographical Modifier: Mid-longitudinal (SRT, G-A188)
D Innom A		Topographical Modifier: Distal (SRT, G-A119)
R Radial A [Label: PV-Art]	Location: Radial Artery (SRT, T-47300)	Laterality: Right (SRT, G-A100)
R P Radial A		Topographical Modifier: Proximal (SRT, G-A118)
R M Radial A		Topographical Modifier: Mid-longitudinal (SRT, G-A188)
R D Radial A		Topographical Modifier: Distal (SRT, G-A119)
R Subclav A [Label: PV-Art]	Location: Subclavian Artery (SRT, T-46100)	Laterality: Right (SRT, G-A100)
R P Subclav A		Topographical Modifier: Proximal (SRT, G-A118)
R M Subclav A		Topographical Modifier: Mid-longitudinal (SRT, G-A188)
R D Subclav A		Topographical Modifier: Distal (SRT, G-A119)
R Ulnar A [Label: PV-Art]	Location: Ulnar Artery (SRT, T-47200)	Laterality: Right (SRT, G-A100)
R P Ulnar A		Topographical Modifier: Proximal (SRT, G-A118)
R M Ulnar A		Topographical Modifier: Mid-longitudinal (SRT, G-A188)
R D Ulnar A		Topographical Modifier: Distal (SRT, G-A119)

**12.12 Vascular Structure of Kidney (Left Side)**

Label	Code Meaning (Coding Scheme Designator, Code Value)	Modifiers
<b>Vascular Structure of Kidney</b>	Finding Site: Vascular Structure of Kidney (SRT, T-71019)	Laterality: Left (SRT, G-A101)
Renal A [Labels: Abd, Renal]	Location: Renal Artery (SRT, T-46600)	Laterality: Left (SRT, G-A101)
L P Renal A		Topographical Modifier: Proximal (SRT, G-A118)
L M Renal A		Topographical Modifier: Mid-longitudinal (SRT, G-A188)
L D Renal A		Topographical Modifier: Distal (SRT, G-A119)
Segmental A [Label: Renal]	Location: Segmental Artery (SRT, T-46659)	Laterality: Left (SRT, G-A101)
Arcuate A [Label: Renal]	Location: Arcuate Artery of the Kidney (SRT, T-4668A)	Laterality: Left (SRT, G-A101)
Interlobar A [Label: Renal]	Location: Interlobar Artery of Kidney (SRT, T-4667D)	Laterality: Left (SRT, G-A101)
Renal V [Labels: Abd, Renal]	Location: Renal Vein (SRT, T-48740)	Laterality: Left (SRT, G-A101)

**12.13 Vascular Structure of Kidney (Right Side)**

Label	Code Meaning (Coding Scheme Designator, Code Value)	Modifiers
<b>Vascular Structure of Kidney</b>	Finding Site: Vascular Structure of Kidney (SRT, T-71019)	Laterality: Right (SRT, G-A100)
Renal A [Labels: Abd, Renal]	Location: Renal Artery (SRT, T-46600)	Laterality: Right (SRT, G-A100)
R P Renal A		Topographical Modifier: Proximal (SRT, G-A118)
R M Renal A		Topographical Modifier: Mid-longitudinal (SRT, G-A188)
R D Renal A		Topographical Modifier: Distal (SRT, G-A119)
Segmental A [Label: Renal]	Location: Segmental Artery (SRT, T-46659)	Laterality: Right (SRT, G-A100)
Arcuate A [Label: Renal]	Location: Arcuate Artery of the Kidney (SRT, T-4668A)	Laterality: Right (SRT, G-A100)
Interlobar A [Label: Renal]	Location: Interlobar Artery of Kidney (SRT, T-4667D)	Laterality: Right (SRT, G-A100)
Renal V [Labels: Abd, Renal]	Location: Renal Vein (SRT, T-48740)	Laterality: Right (SRT, G-A100)

**12.14 Artery of Abdomen (Unilateral)**

Label	Code Meaning (Coding Scheme Designator, Code Value)	Modifiers
<b>Artery of Abdomen</b>	Finding Site: Artery of Abdomen (SRT, T-46002)	Laterality: Unilateral (SRT, G-C171)
Aorta [Labels: Abd, CV, Renal] Abd Aorta [Labels: PV-Art]	Location: Aorta (SRT, T-42000)	
P Aorta P Abd Aorta		Topographical Modifier: Proximal (SRT, G-A118)
M Aorta M Abd Aorta		Topographical Modifier: Mid-longitudinal (SRT, G-A188)
D Aorta D Abd Aorta		Topographical Modifier: Distal (SRT, G-A119)
Celiac A [Label: Abd]	Location: Celiac Axis (SRT, T-46400)	
Common Hepatic Artery [Label: Abd]	Location: Common Hepatic Artery (SRT, T-46421)	
P Hepatic A		Topographical Modifier: Proximal (SRT, G-A118)
M Hepatic A		Topographical Modifier: Mid-longitudinal (SRT, G-A188)
D Hepatic A		Topographical Modifier: Distal (SRT, G-A119)
Gastric A [Label: Abd]	Location: Gastric Artery (SRT, T-46410)	
P Gastric A		Topographical Modifier: Proximal (SRT, G-A118)
M Gastric A		Topographical Modifier: Mid-longitudinal (SRT, G-A188)
D Gastric A		Topographical Modifier: Distal (SRT, G-A119)
Inferior Mesenteric Artery [Label: Abd]	Location: Inferior Mesenteric Artery (SRT, T-46520)	
P IMA		Topographical Modifier: Proximal (SRT, G-A118)
M IMA		Topographical Modifier: Mid-longitudinal (SRT, G-A188)
D IMA		Topographical Modifier: Distal (SRT, G-A119)
Splenic Artery [Label: Abd]	Location: Splenic Artery (SRT, T-46460)	
P Splenic A		Topographical Modifier: Proximal (SRT, G-A118)
M Splenic A		Topographical Modifier: Mid-longitudinal (SRT, G-A188)
D Splenic A		Topographical Modifier: Distal (SRT, G-A119)
Superior Mesenteric Artery [Label: Abd]	Location: Superior Mesenteric Artery (SRT, T-46510)	
P SMA		Topographical Modifier: Proximal (SRT, G-A118)
M SMA		Topographical Modifier: Mid-longitudinal (SRT, G-A188)
D SMA		Topographical Modifier: Distal (SRT, G-A119)
Bifurcation A [Label: Abd]	Location: Bifurcation Artery (99ANTARES, BifurA)	

**12.15 Vein of Abdomen (Left Side)**

Label	Code Meaning (Coding Scheme Designator, Code Value)	Modifiers
<b>Vein of Abdomen</b>	Finding Site: Vein of Abdomen (SRT, T-487A0)	Laterality: Left (SRT, G-A101)
Iliac V [Label: Abd]	Location: Common Iliac Vein (SRT, T-48920)	
L P Iliac V		Topographical Modifier: Proximal (SRT, G-A118)
L M Iliac V		Topographical Modifier: Mid-longitudinal (SRT, G-A188)
L D Iliac V		Topographical Modifier: Distal (SRT, G-A119)

**12.16 Vein of Abdomen (Right Side)**

Label	Code Meaning (Coding Scheme Designator, Code Value)	Modifiers
<b>Vein of Abdomen</b>	Finding Site: Vein of Abdomen (SRT, T-487A0)	Laterality: Right (SRT, G-A100)
Iliac V [Label: Abd]	Location: Common Iliac Vein (SRT, T-48920)	
R P Iliac V		Topographical Modifier: Proximal (SRT, G-A118)
R M Iliac V		Topographical Modifier: Mid-longitudinal (SRT, G-A188)
R D Iliac V		Topographical Modifier: Distal (SRT, G-A119)

**12.17 Vein of Abdomen (Unilateral)**

Label	Code Meaning (Coding Scheme Designator, Code Value)	Modifiers
<b>Vein of Abdomen</b>	Finding Site: Vein of Abdomen (SRT, T-487A0)	Laterality: Unilateral (SRT, G-C171)
Left Hepatic Vein [Label: Abd]	Location: Left Hepatic Vein (SRT, T-48727)	
L P Hepatic V		Topographical Modifier: Proximal (SRT, G-A118)
L M Hepatic V		Topographical Modifier: Mid-longitudinal (SRT, G-A188)
L D Hepatic V		Topographical Modifier: Distal (SRT, G-A119)
Middle Hepatic Vein [Label: Abd]	Location: Middle Hepatic Vein (SRT, T-48726)	
M P Hepatic V		Topographical Modifier: Proximal (SRT, G-A118)
M M Hepatic V		Topographical Modifier: Mid-longitudinal (SRT, G-A188)
M D Hepatic V		Topographical Modifier: Distal (SRT, G-A119)
Right Hepatic Vein [Label: Abd]	Location: Right Hepatic Vein (SRT, T-48725)	
R P Hepatic V		Topographical Modifier: Proximal (SRT, G-A118)
R M Hepatic V		Topographical Modifier: Mid-longitudinal (SRT, G-A188)
R D Hepatic V		Topographical Modifier: Distal (SRT, G-A119)

Label	Code Meaning (Coding Scheme Designator, Code Value)	Modifiers
Portal Vein [Label: Abd]	Location:Portal Vein (SRT, T-488810)	
P Portal V		Topographical Modifier: Proximal (SRT, G-A118)
M Portal V		Topographical Modifier: Mid-longitudinal (SRT, G-A188)
D Portal V		Topographical Modifier: Distal (SRT, G-A119)
Inferior Vena Cava [Labels: Abd, Renal]	Location: Inferior Vena Cava (SRT, T-48710)	
P IVC		Topographical Modifier: Proximal (SRT, G-A118)
M IVC		Topographical Modifier: Mid-longitudinal (SRT, G-A188)
D IVC		Topographical Modifier: Distal (SRT, G-A119)
Splenic Vein [Label: Abd]	Location: Splenic Vein (SRT, T-48890)	
P Splenic V		Topographical Modifier: Proximal (SRT, G-A118)
M Splenic V		Topographical Modifier: Mid-longitudinal (SRT, G-A188)
D Splenic V		Topographical Modifier: Distal (SRT, G-A119)
Superior Mesenteric Vein [Label: Abd]	Location: Superior Mesenteric Vein (SRT, T-48840)	
P SMV		Topographical Modifier: Proximal (SRT, G-A118)
M SMV		Topographical Modifier: Mid-longitudinal (SRT, G-A188)
D SMV		Topographical Modifier: Distal (SRT, G-A119)

## 12.18 Ultrasound Graft

Label	Code Meaning (Coding Scheme Designator, Code Value)	Modifiers
<b>Ultrasound Graft</b>	Finding Site: Vascular Graft (SRT, T-D000F)	
Left Abominal Anastomosis Artery [Label: Abd]	Location: Abdominal Anastomosis Artery (99ANTARES, AbdAnastA)	Laterality: Left (SRT, G-A101)
L P Abd Anast A		Location: Proximal Anastomosis (SRT, G-D871)
L M Abd Anast A		Location: Middle Anastomosis (99ANTARES, MidAnast)
L D Abd Anast A		Location: Distal Anastomosis (SRT, G-D872)
Right Abominal Anastomosis Artery [Label: Abd]	Location: Abdominal Anastomosis Artery (99ANTARES, AbdAnastA)	Laterality: Right (SRT, G-A100)
R P Abd Anast A		Location: Proximal Anastomosis (SRT, G-D871)
R M Abd Anast A		Location: Middle Anastomosis (99ANTARES, MidAnast)
R D Abd Anast A		Location: Distal Anastomosis (SRT, G-D872)

Label	Code Meaning (Coding Scheme Designator, Code Value)	Modifiers
Left Abominal Anastomosis Vein [Label: Abd]	Location: Abdominal Anastomosis Vein (99ANTARES, AbdAnastV)	Laterality: Left (SRT, G-A101)
L P Abd Anast V		Location: Proximal Anastomosis (SRT, G-D871)
L M Abd Anast V		Location: Middle Anastomosis (99ANTARES, MidAnast)
L D Abd Anast V		Location: Distal Anastomosis (SRT, G-D872)
Right Abominal Anastomosis Vein [Label: Abd]	Location: Abdominal Anastomosis Vein (99ANTARES, AbdAnastV)	Laterality: Right (SRT, G-A100)
R P Abd Anast V		Location: Proximal Anastomosis (SRT, G-D871)
R M Abd Anast V		Location: Middle Anastomosis (99ANTARES, MidAnast)
R D Abd Anast V		Location: Distal Anastomosis (SRT, G-D872)
Left Renal Anastomosis Artery [Label: Renal]	Location: Renal Anastomosis Artery (99ANTARES, RenalAnastA)	Laterality: Left (SRT, G-A101)
L P Renal Anast A		Location: Proximal Anastomosis (SRT, G-D871)
L M Renal Anast A		Location: Middle Anastomosis (99ANTARES, MidAnast)
L D Renal Anast A		Location: Distal Anastomosis (SRT, G-D872)
Right Renal Anastomosis Artery [Label: Renal]	Location: Renal Anastomosis Artery (99ANTARES, RenalAnastA)	Laterality: Right (SRT, G-A100)
R P Renal Anast A		Location: Proximal Anastomosis (SRT, G-D871)
R M Renal Anast A		Location: Middle Anastomosis (99ANTARES, MidAnast)
R D Renal Anast A		Location: Distal Anastomosis (SRT, G-D872)
Left Renal Anastomosis Vein [Label: Renal]	Location: Renal Anastomosis Vein (99ANTARES, RenalAnastV)	Laterality: Left (SRT, G-A101)
L P Renal Anast V		Location: Proximal Anastomosis (SRT, G-D871)
L M Renal Anast V		Location: Middle Anastomosis (99ANTARES, MidAnast)
L D Renal Anast V		Location: Distal Anastomosis (SRT, G-D872)
Right Renal Anastomosis Vein [Label: Renal]	Location: Renal Anastomosis Vein (99ANTARES, RenalAnastV)	Laterality: Right (SRT, G-A100)
R P Renal Anast V		Location: Proximal Anastomosis (SRT, G-D871)
R M Renal Anast V		Location: Middle Anastomosis (99ANTARES, MidAnast)
R D Renal Anast V		Location: Distal Anastomosis (SRT, G-D872)

**12.19 Private Section: Mixed Carotid Ratios**

Label	Code Meaning (Coding Scheme Designator, Code Value)	Modifiers
<b>Mixed Carotid Ratios</b>	Container: Mixed Carotid Ratios (99ANTARES, MxCarotidRatios)	
R Prox CCA/L Prox CCA	Right CCA/Left CCA (99ANTARES, RCCAoverLCCA)	Topographical Modifier: Proximal (SRT, G-A118)
R Mid CCA/L Mid CCA	Right CCA/Left CCA (99ANTARES, RCCAoverLCCA)	Topographical Modifier: Mid-longitudinal (SRT, G-A188)
R Dist CCA/L Dist CCA	Right CCA/Left CCA (99ANTARES, RCCAoverLCCA)	Topographical Modifier: Distal (SRT, G-A119)

**12.20 Private Section: Kidney**

Label	Code Meaning (Coding Scheme Designator, Code Value)	Modifiers
<b>Kidney</b>	Container: Kidney (99ANTARES, Kidney)	
L Kidney	Left Kidney Distance (99ANTARES, LKidneyDist)	
L Kidney Mean [2D-Mode]	Left Kidney Distance (99ANTARES, LKidneyDist)	Derivation: Mean (SRT, R-00317)
L Kidney V	Left Kidney Volume (99ANTARES, LKidneyVol)	
L Kidney Mean [Volume]	Left Kidney Volume (99ANTARES, LKidneyVol)	Derivation: Mean (SRT, R-00317)
L Kidney D1	Left Kidney Volume: Distance 1 (99ANTARES, LKidneyVolD1)	
L Kidney D2	Left Kidney Volume: Distance 2 (99ANTARES, LKidneyVolD2)	
L Kidney D3	Left Kidney Volume: Distance 3 (99ANTARES, LKidneyVolD3)	
R Kidney	Right Kidney Distance (99ANTARES, RKidneyDist)	
R Kidney Mean [2D-Mode]	Right Kidney Distance (99ANTARES, RKidneyDist)	Derivation: Mean (SRT, R-00317)
R Kidney V	Right Kidney Volume (99ANTARES, RKidneyVol)	
R Kidney Mean [Volume]	Right Kidney Volume (99ANTARES, RKidneyVol)	Derivation: Mean (SRT, R-00317)
R Kidney D1	Right Kidney Volume: Distance 1 (99ANTARES, RKidneyVolD1)	
R Kidney D2	Right Kidney Volume: Distance 2 (99ANTARES, RKidneyVolD2)	
R Kidney D3	Right Kidney Volume: Distance 3 (99ANTARES, RKidneyVolD3)	

**12.21 Private Section: Ureter**

Label	Code Meaning (Coding Scheme Designator, Code Value)	Modifiers
<b>Ureter</b>	Container: Ureter (99ANTARES, Ureter)	
L Ureter	Left Ureter Distance (99ANTARES, LUreterDist)	
L Ureter Mean	Left Ureter Distance (99ANTARES, LUreterDist)	Derivation: Mean (SRT, R-00317)
R Ureter	Right Ureter Distance (99ANTARES, RUreterDist)	
R Ureter Mean	Right Ureter Distance (99ANTARES, RUreterDist)	Derivation: Mean (SRT, R-00317)

**12.22 Private Section: Bladder**

Label	Code Meaning (Coding Scheme Designator, Code Value)	Modifiers
<b>Bladder</b>	Container: Bladder (99ANTARES, Bladder)	
Micturated	Micturated Volume (99ANTARES, MicturatedVol)	
PreVoid Bld V	Pre-Void Volume (99ANTARES, PreVoidVol)	
PreVoid Bld Mean	Pre-Void Volume (99ANTARES, PreVoidVol)	Derivation: Mean (SRT, R-00317)
PreVoid Bld D1	Pre-Void Volume: Distance 1 (99ANTARES, PreVoidVolD1)	
PreVoid Bld D2	Pre-Void Volume: Distance 2 (99ANTARES, PreVoidVolD2)	
PreVoid Bld D3	Pre-Void Volume: Distance 3 (99ANTARES, PreVoidVolD3)	
PostVoid Bld V	Post-Void Volume (99ANTARES, PostVoidVol)	
PostVoid Bld Mean	Post-Void Volume (99ANTARES, PostVoidVol)	Derivation: Mean (SRT, R-00317)
PostVoid Bld D1	Post-Void Volume: Distance 1 (99ANTARES, PostVoidVolD1)	
PostVoid Bld D2	Post-Void Volume: Distance 2 (99ANTARES, PostVoidVolD2)	
PostVoid Bld D3	Post-Void Volume: Distance 3 (99ANTARES, PostVoidVolD3)	

**12.23 Private Section: Liver, Gall Bladder, Pancreas**

Label	Code Meaning (Coding Scheme Designator, Code Value)	Modifiers
<b>Liver, Gall Bladder, Pancreas</b>	Container: Liver, Gall Bladder, Pancreas (99ANTARES, LiverGallBPancr)	
Liver	Liver Distance (99ANTARES, LiverDist)	
Liver Mean [2D-Mode]	Liver Distance (99ANTARES, LiverDist)	Derivation: Mean (SRT, R-00317)
Liver V	Liver Volume (99ANTARES, LiverVol)	
Liver Mean [Volume]	Liver Volume (99ANTARES, LiverVol)	Derivation: Mean (SRT, R-00317)
Liver D1	Liver Volume: Distance 1 (99ANTARES, LiverVolD1)	
Liver D2	Liver Volume: Distance 2 (99ANTARES, LiverVolD2)	
Liver D3	Liver Volume: Distance 3 (99ANTARES, LiverVolD3)	
CHD	Common Hepatic Duct Distance (99ANTARES, CHDuctDist)	
CHD Mean	Common Hepatic Duct Distance (99ANTARES, CHDuctDist)	Derivation: Mean (SRT, R-00317)
CBD	Common Bile Duct Distance (99ANTARES, CBDuctDist)	
CBD Mean	Common Bile Duct Distance (99ANTARES, CBDuctDist)	Derivation: Mean (SRT, R-00317)
GB Wall	Gall Bladder Wall Thickness (99ANTARES, GallBWallThk)	
GB Wall Mean	Gall Bladder Wall Thickness (99ANTARES, GallBWallThk)	Derivation: Mean (SRT, R-00317)

Label	Code Meaning (Coding Scheme Designator, Code Value)	Modifiers
Panc duct	Pancreatic Duct Distance (99ANTARES, PancrDuctDist)	
Panc duct Mean	Pancreatic Duct Distance (99ANTARES, PancrDuctDist)	Derivation: Mean (SRT, R-00317)

### 12.24 Private Section: Spleen

Label	Code Meaning (Coding Scheme Designator, Code Value)	Modifiers
<b>Spleen</b>	Container: Spleen (99ANTARES, Spleen)	
Spleen	Spleen Distance (99ANTARES, SpleenDist)	
Spleen Mean [2D-Mode]	Spleen Distance (99ANTARES, SpleenDist)	Derivation: Mean (SRT, R-00317)
Spleen V	Spleen Volume (99ANTARES, SpleenVol)	
Spleen Mean [Volume]	Spleen Volume (99ANTARES, SpleenVol)	Derivation: Mean (SRT, R-00317)
Spleen D1	Spleen Volume: Distance 1 (99ANTARES, SpleenVolD1)	
Spleen D2	Spleen Volume: Distance 2 (99ANTARES, SpleenVolD2)	
Spleen D3	Spleen Volume: Distance 3 (99ANTARES, SpleenVolD3)	

## 13.0 Appendix C: Echocardiography Structured Report

This appendix lists the DICOM Structured Report (SR) mappings used in the Cardiac Structured Reports of Antares SR files, version 5.0.

The mappings are organized in a manner similar to the DICOM SR Templates as described in PS 3.16-2004 of the DICOM Standard. The “Label” column identifies the on-screen report label associated with a measurement. All private code values use the Coding Scheme Designator “99SIEMENSUS”.

The Cardiac Report mappings follow the DICOM SR Template TID 5200: Echocardiography Procedure Report. The Qp-Qs and Qp/Qs measurements that are displayed on the report page are not available in the SR.

Notation:

[ ... ] is additional information about the label

### TID5200: Echocardiography Procedure Report

#### 13.1 Left Ventricle

Label (Heading: Measurement)	Code Meaning (Coding Scheme Designator, Code Value)	Modifiers
<b>Left Ventricle</b>	Finding Site: Left Ventricle (SRT, T-32600)	
Aortic Valve: CI	Cardiac Index (SRT, F-32110)	Finding Site: Left Ventricle Outflow Tract (SRT, T-32650) Measurement Method: Doppler Volume Flow (DCM, 125219)
Aortic Valve: CO	Cardiac Output (SRT, F-32100)	Finding Site: Left Ventricle Outflow Tract (SRT, T-32650) Measurement Method: Doppler Volume Flow (DCM, 125219)
Aortic Valve: IVRT Mitral Valve: IVRT	Left Ventricular Isovolumic Relaxation Time (LN, 18071-1)	
Aortic Valve: LVOT diam Mitral Valve: LVOT diam	Cardiovascular Orifice Diameter (SRT, G-038F)	Finding Site: Left Ventricle Outflow Tract (SRT, T-32650)
Aortic Valve: LVOT PGmax	Peak Gradient (LN, 20247-3)	Finding Site: Left Ventricle Outflow Tract (SRT, T-32650) Direction of Flow: Antegrade Flow (SRT, R-42047)
Aortic Valve: LVOT PGmean	Mean Gradient (LN, 20256-4)	Finding Site: Left Ventricle Outflow Tract (SRT, T-32650) Direction of Flow: Antegrade Flow (SRT, R-42047)
Aortic Valve: LVOT Vmax	Peak Systolic Velocity (LN, 11726-7)	Finding Site: Left Ventricle Outflow Tract (SRT, T-32650) Direction of Flow: Antegrade Flow (SRT, R-42047)
Aortic Valve: LVOT Vmean	Mean Velocity (LN, 20352-1)	Finding Site: Left Ventricle Outflow Tract (SRT, T-32650) Direction of Flow: Antegrade Flow (SRT, R-42047)

Label (Heading: Measurement)	Code Meaning (Coding Scheme Designator, Code Value)	Modifiers
Aortic Valve: LVOT VTI Mitral Valve: LVOT VTI	Velocity Time Integral (LN, 20354-7)	Finding Site: Left Ventricle Outflow Tract (SRT, T-32650) Direction of Flow: Antegrade Flow (SRT, R-42047)
Aortic Valve: SI	Stroke Index (SRT, F-00078)	Finding Site: Left Ventricle Outflow Tract (SRT, T-32650) Measurement Method: Doppler Volume Flow (DCM, 125219)
Aortic Valve: SV	Stroke Volume (SRT, F-32120)	Finding Site: Left Ventricle Outflow Tract (SNM3, T-32650) Measurement Method: Doppler Volume Flow (DCM, 125219)
Aortic Valve: VSD PGmax	Peak Gradient (LN, 20247-3)	Finding Site: Ventricular Septal Defect (SRT, D4-31150)
Aortic Valve: VSD Vmax	Peak Systolic Velocity (LN, 11726-7)	Finding Site: Ventricular Septal Defect (SRT, D4-31150)
Mitral Valve: CO	Cardiac Output (SRT, F-32100)	Finding Site: Left Ventricle Outflow Tract (SRT, T-32650) Image Mode: Doppler Mode (99SIEMENSUS, DOPPLER) Measurement Method: Doppler Volume Flow (DCM, 125219)
Mitral Valve: MV LVIMP	Left Ventricular Index of Myocardial Performance (SRT, G-037F)	
Mitral Valve: SV	Stroke Volume (SRT, F-32120)	Finding Site: Left Ventricle Outflow Tract (SRT, T-32650) Image Mode: Doppler Mode (99SIEMENSUS, DOPPLER) Measurement Method: Doppler Volume Flow (DCM, 125219)
Cubed(2D): CI	Cardiac Index (SRT, F-32110)	Image Mode: 2D mode (SRT, G-03A2) Measurement Method: Cube Method (DCM, 125206)
Cubed(2D): CO	Cardiac Output (SRT, F-32100)	Image Mode: 2D mode (SRT, G-03A2) Measurement Method: Cube Method (DCM, 125206)
Cubed(2D): EDV	Left Ventricular End Diastolic Volume (LN, 18026-5)	Image Mode: 2D mode (SRT, G-03A2) Measurement Method: Cube Method (DCM, 125206)
Cubed(2D): EF	Left Ventricular Ejection Fraction (LN, 18043-0)	Image Mode: 2D mode (SRT, G-03A2) Measurement Method: Cube Method (DCM, 125206)
Cubed(2D): ESV	Left Ventricular End Systolic Volume (LN, 18148-7)	Image Mode: 2D mode (SRT, G-03A2) Measurement Method: Cube Method (DCM, 125206)
Cubed(2D): FS	Left Ventricular Fractional Shortening (LN, 18051-3)	Image Mode: 2D mode (SRT, G-03A2) Measurement Method: Cube Method (DCM, 125206)
Cubed(2D): HR	Heart Rate (LN, 8867-4)	Image Mode: 2D mode (SRT, G-03A2) Measurement Method: Cube Method (DCM, 125206)
Cubed(2D): IVSd	Interventricular Septum Diastolic Thickness (LN, 18154-5)	Image Mode: 2D mode (SRT, G-03A2) Measurement Method: Cube Method (DCM, 125206)
Cubed(2D): IVSs	Interventricular Septum Systolic Thickness (LN, 18158-6)	Image Mode: 2D mode (SRT, G-03A2) Measurement Method: Cube Method (DCM, 125206)
Cubed(2D): LVIDd	Left Ventricle Internal End Diastolic Dimension (LN, 29436-3)	Image Mode: 2D mode (SRT, G-03A2) Measurement Method: Cube Method (DCM, 125206)
Cubed(2D): LVIDs	Left Ventricle Internal Systolic Dimension (LN, 29438-9)	Image Mode: 2D mode (SRT, G-03A2) Measurement Method: Cube Method (DCM, 125206)

Label (Heading: Measurement)	Code Meaning (Coding Scheme Designator, Code Value)	Modifiers
Cubed(2D): LVPWd	Left Ventricle Posterior Wall Diastolic Thickness (LN, 18152-9)	Image Mode: 2D mode (SRT, G-03A2) Measurement Method: Cube Method (DCM, 125206)
Cubed(2D): LVPWs	Left Ventricle Posterior Wall Systolic Thickness (LN, 18156-0)	Image Mode: 2D mode (SRT, G-03A2) Measurement Method: Cube Method (DCM, 125206)
Cubed(2D): SI	Stroke Index (SRT, F-00078)	Image Mode: 2D mode (SRT, G-03A2) Measurement Method: Cube Method (DCM, 125206)
Cubed(2D): SV	Stroke Volume (SRT, F-32120)	Image Mode: 2D mode (SRT, G-03A2) Measurement Method: Cube Method (DCM, 125206)
DTI: Aa(l)	LV Peak Diastolic Tissue Velocity During Atrial Systole (SRT, G-037C)	Finding Site: Lateral Mitral Annulus (SRT, G-0392)
DTI: Aa(m)	LV Peak Diastolic Tissue Velocity During Atrial Systole (SRT, G-037C)	Finding Site: Medial Mitral Annulus (SRT, G-0391)
DTI: ARa(l)	Mitral Valve DTI acceleration rate of Ea (99SIEMENSUS, CA_MV_ARa)	Finding Site: Lateral Mitral Annulus (SRT, G-0392)
DTI: ARa(m)	Mitral Valve DTI acceleration rate of Ea (99SIEMENSUS, CA_MV_ARa)	Finding Site: Medial Mitral Annulus (SRT, G-0391)
DTI: ATa(l)	Mitral Valve DTI acceleration time of Ea (99SIEMENSUS, CA_MV_ATa)	Finding Site: Lateral Mitral Annulus (SRT, G-0392)
DTI: ATa(m)	Mitral Valve DTI acceleration time of Ea (99SIEMENSUS, CA_MV_ATa)	Finding Site: Medial Mitral Annulus (SRT, G-0391)
DTI: DRa(l)	Mitral Valve DTI deceleration rate of Ea (99SIEMENSUS, CA_MV_DRa)	Finding Site: Lateral Mitral Annulus (SRT, G-0392)
DTI: DRa(m)	Mitral Valve DTI deceleration rate of Ea (99SIEMENSUS, CA_MV_DRa)	Finding Site: Medial Mitral Annulus (SRT, G-0391)
DTI: DTa(l)	Mitral Valve DTI deceleration time of Ea (99SIEMENSUS, CA_MV_DTa)	Finding Site: Lateral Mitral Annulus (SRT, G-0392)
DTI: DTa(m)	Mitral Valve DTI deceleration time of Ea (99SIEMENSUS, CA_MV_DTa)	Finding Site: Medial Mitral Annulus (SRT, G-0391)
DTI: E/Ea(l)	Ratio of MV Peak Velocity to LV Peak Tissue Velocity E-Wave (SRT, G-037B)	Finding Site: Lateral Mitral Annulus (SRT, G-0392)
DTI: E/Ea(m)	Ratio of MV Peak Velocity to LV Peak Tissue Velocity E-Wave (SRT, G-037B)	Finding Site: Medial Mitral Annulus (SRT, G-0391)
DTI: Ea(l)	Left Ventricular Peak Early Diastolic Tissue Velocity (SRT, G-037A)	Finding Site: Lateral Mitral Annulus (SRT, G-0392)
DTI: Ea(m)	Left Ventricular Peak Early Diastolic Tissue Velocity (SRT, G-037A)	Finding Site: Medial Mitral Annulus (SRT, G-0391)
DTI: Ea/Aa(l)	Mitral Valve DTI Ea to Aa Ratio (99SIEMENSUS, CA_MV_Ea2Aa)	Finding Site: Lateral Mitral Annulus (SRT, G-0392)
DTI: Ea/Aa(m)	Mitral Valve DTI Ea to Aa Ratio (99SIEMENSUS, CA_MV_Ea2Aa)	Finding Site: Medial Mitral Annulus (SRT, G-0391)
DTI: Sa(l)	Left Ventricular Peak Systolic Tissue Velocity (SRT, G-037D)	Finding Site: Lateral Mitral Annulus (SRT, G-0392)
DTI: Sa(m)	Left Ventricular Peak Systolic Tissue Velocity (SRT, G-037D)	Finding Site: Medial Mitral Annulus (SRT, G-0391)
LV/Cubed(M): CI	Cardiac Index (SRT, F-32110)	Image Mode: M-Mode (SRT, G-0394) Measurement Method: Cube Method (DCM, 125206)
LV/Cubed(M): CO	Cardiac Output (SRT, F-32100)	Image Mode: M-Mode (SRT, G-0394) Measurement Method: Cube Method (DCM, 125206)

Label (Heading: Measurement)	Code Meaning (Coding Scheme Designator, Code Value)	Modifiers
LV/Cubed(M): EDV	Left Ventricular End Diastolic Volume (LN, 18026-5)	Image Mode: M-Mode (SRT, G-0394) Measurement Method: Cube Method (DCM, 125206)
LV/Cubed(M): EF	Left Ventricular Ejection Fraction (LN, 18043-0)	Image Mode: M-Mode (SRT, G-0394) Measurement Method: Cube Method (DCM, 125206)
LV/Cubed(M): ESV	Left Ventricular End Systolic Volume (LN, 18148-7)	Image Mode: M-Mode (SRT, G-0394) Measurement Method: Cube Method (DCM, 125206)
LV/Cubed(M): FS	Left Ventricular Fractional Shortening (LN, 18051-3)	Image Mode: M-Mode (SRT, G-0394) Measurement Method: Cube Method (DCM, 125206)
LV/Cubed(M): HR	Heart Rate (LN, 8867-4)	Image Mode: M-Mode (SRT, G-0394) Measurement Method: Cube Method (DCM, 125206)
LV/Cubed(M): IVSd	Interventricular Septum Diastolic Thickness (LN, 18154-5)	Image Mode: M-Mode (SRT, G-0394) Measurement Method: Cube Method (DCM, 125206)
LV/Cubed(M): IVSs	Interventricular Septum Systolic Thickness (LN, 18158-6)	Image Mode: M-Mode (SRT, G-0394) Measurement Method: Cube Method (DCM, 125206)
LV/Cubed(M): LV MASS	Left Ventricle Mass (LN, 18087-7)	Image Mode: M-Mode (SRT, G-0394) Measurement Method: Cube Method (DCM, 125206)
LV/Cubed(M): LV MASS-c	Left Ventricle Mass corrected (99SIEMENSUS, CA_LV_MASSc)	Image Mode: M-Mode (SRT, G-0394) Measurement Method: Cube Method (DCM, 125206)
LV/Cubed(M): LV MASS-l	Left Ventricle Mass (LN, 18087-7)	Image Mode: M-Mode (SRT, G-0394) Index: Body Surface Area (LN, 8277-6) Measurement Method: Cube Method (DCM, 125206)
LV/Cubed(M): LVIDd	Left Ventricle Internal End Diastolic Dimension (LN, 29436-3)	Image Mode: M-Mode (SRT, G-0394) Measurement Method: Cube Method (DCM, 125206)
LV/Cubed(M): LVIDs	Left Ventricle Internal Systolic Dimension (LN, 29438-9)	Image Mode: M-Mode (SRT, G-0394) Measurement Method: Cube Method (DCM, 125206)
LV/Cubed(M): LVPWd	Left Ventricle Posterior Wall Diastolic Thickness (LN, 18152-9)	Image Mode: M-Mode (SRT, G-0394) Measurement Method: Cube Method (DCM, 125206)
LV/Cubed(M): LVPWs	Left Ventricle Posterior Wall Systolic Thickness (LN, 18156-0)	Image Mode: M-Mode (SRT, G-0394) Measurement Method: Cube Method (DCM, 125206)
LV/Cubed(M): mVcf	Systolic Index (99SIEMENSUS, CA_LF_VCF)	Image Mode: M-Mode (SRT, G-0394) Measurement Method: Cube Method (DCM, 125206)
LV/Cubed(M): SI	Stroke Index (SRT, F-00078)	Image Mode: M-Mode (SRT, G-0394) Measurement Method: Cube Method (DCM, 125206)
LV/Cubed(M): SV	Stroke Volume (SRT, F-32120)	Image Mode: M-Mode (SRT, G-0394) Measurement Method: Cube Method (DCM, 125206)
LV/Teichholz(M): CI	Cardiac Index (SRT, F-32110)	Image Mode: M-Mode (SRT, G-0394) Measurement Method: Teichholz (DCM, 125209)

Label (Heading: Measurement)	Code Meaning (Coding Scheme Designator, Code Value)	Modifiers
LV/Teichholz(M): CO	Cardiac Output (SRT, F-32100)	Image Mode: M-Mode (SRT, G-0394) Measurement Method: Teichholz (DCM, 125209)
LV/Teichholz(M): EDV	Left Ventricular End Diastolic Volume (LN, 18026-5)	Image Mode: M-Mode (SRT, G-0394) Measurement Method: Teichholz (DCM, 125209)
LV/Teichholz(M): EF	Left Ventricular Ejection Fraction (LN, 18043-0)	Image Mode: M-Mode (SRT, G-0394) Measurement Method: Teichholz (DCM, 125209)
LV/Teichholz(M): ESV	Left Ventricular End Systolic Volume (LN, 18148-7)	Image Mode: M-Mode (SRT, G-0394) Measurement Method: Teichholz (DCM, 125209)
LV/Teichholz(M): FS	Left Ventricular Fractional Shortening (LN, 18051-3)	Image Mode: M-Mode (SRT, G-0394) Measurement Method: Teichholz (DCM, 125209)
LV/Teichholz(M): HR	Heart Rate (LN, 8867-4)	Image Mode: M-Mode (SRT, G-0394) Measurement Method: Teichholz (DCM, 125209)
LV/Teichholz(M): IVSd	Interventricular Septum Diastolic Thickness (LN, 18154-5)	Image Mode: M-Mode (SRT, G-0394) Measurement Method: Teichholz (DCM, 125209)
LV/Teichholz(M): IVSs	Interventricular Septum Systolic Thickness (LN, 18158-6)	Image Mode: M-Mode (SRT, G-0394) Measurement Method: Teichholz (DCM, 125209)
LV/Teichholz(M): LV MASS	Left Ventricle Mass (LN, 18087-7)	Image Mode: M-Mode (SRT, G-0394) Measurement Method: Teichholz (DCM, 125209)
LV/Teichholz(M): LV MASS-c	Left Ventricle Mass corrected (99SIEMENSUS, CA_LV_MASSc)	Image Mode: M-Mode (SRT, G-0394) Measurement Method: Teichholz (DCM, 125209)
LV/Teichholz(M): LV MASS-l	Left Ventricle Mass (LN, 18087-7)	Image Mode: M-Mode (SRT, G-0394) Index: Body Surface Area (LN, 8277-6) Measurement Method: Teichholz (DCM, 125209)
LV/Teichholz(M): LVIDd	Left Ventricle Internal End Diastolic Dimension (LN, 29436-3)	Image Mode: M-Mode (SRT, G-0394) Measurement Method: Teichholz (DCM, 125209)
LV/Teichholz(M): LVIDs	Left Ventricle Internal Systolic Dimension (LN, 29438-9)	Image Mode: M-Mode (SRT, G-0394) Measurement Method: Teichholz (DCM, 125209)
LV/Teichholz(M): LVPWd	Left Ventricle Posterior Wall Diastolic Thickness (LN, 18152-9)	Image Mode: M-Mode (SRT, G-0394) Measurement Method: Teichholz (DCM, 125209)
LV/Teichholz(M): LVPWs	Left Ventricle Posterior Wall Systolic Thickness (LN, 18156-0)	Image Mode: M-Mode (SRT, G-0394) Measurement Method: Teichholz (DCM, 125209)
LV/Teichholz(M): mVcf	Systolic Index (99SIEMENSUS, CA_LF_VCF)	Image Mode: M-Mode (SRT, G-0394) Measurement Method: Teichholz (DCM, 125209)
LV/Teichholz(M): SI	Stroke Index (SRT, F-00078)	Image Mode: M-Mode (SRT, G-0394) Measurement Method: Teichholz (DCM, 125209)
LV/Teichholz(M): SV	Stroke Volume (SRT, F-32120)	Image Mode: M-Mode (SRT, G-0394) Measurement Method: Teichholz (DCM, 125209)

Label (Heading: Measurement)	Code Meaning (Coding Scheme Designator, Code Value)	Modifiers
LV MASS A-L: A Sax Endo	Left Ventricular Diastolic Area (SRT, G-0375)	Image Mode: 2D mode (SRT, G-03A2) Image View: Parasternal Short Axis at the Papillary Muscle Level (SRT, G-039B) Measurement Method: Left Ventricle Mass by Area Length (99SIEMENSUS, LVMassAL)
LV MASS A-L: A Sax Epi	Left Ventricle Epicardial Diastolic Area, psax pap view (SRT, G-0379)	Image Mode: 2D mode (SRT, G-03A2) Measurement Method: Left Ventricle Mass by Area Length (99SIEMENSUS, LVMassAL)
LV MASS A-L: LV MASS	Left Ventricle Mass (LN, 18087-7)	Image Mode: 2D mode (SRT, G-03A2) Measurement Method: Left Ventricle Mass by Area Length (99SIEMENSUS, LVMassAL)
LV MASS A-L: LV MASS-l	Left Ventricle Mass (LN, 18087-7)	Image Mode: 2D mode (SRT, G-03A2) Index: Body Surface Area (LN, 8277-6) Measurement Method: Left Ventricle Mass by Area Length (99SIEMENSUS, LVMassAL)
LV MASS A-L: LVL	Left Ventricle Diastolic Major Axis (LN, 18077-8)	Image Mode: 2D mode (SRT, G-03A2)
LV MASS A-L: t	Myocardial Thickness calculated from Short Axis Epicardial and Cavity Areas (99SIEMENSUS, CA_LV_MyoTh)	Image Mode: 2D mode (SRT, G-03A2)
LV MASS T-E: a	Left Ventricle Semi-major Axis Diastolic Dimension (SRT, G-0377)	Measurement Method: Left Ventricle Mass by Truncated Ellipse (DCM, 125222)
LV MASS T-E: A Sax Endo	Left Ventricular Diastolic Area (SRT, G-0375)	Image View: Parasternal Short Axis at the Papillary Muscle Level (SRT, G-039B) Measurement Method: Left Ventricle Mass by Truncated Ellipse (DCM, 125222)
LV MASS T-E: A Sax Epi	Left Ventricle Epicardial Diastolic Area, psax pap view (SRT, G-0379)	Measurement Method: Left Ventricle Mass by Truncated Ellipse (DCM, 125222)
LV MASS T-E: b	Short axis radius calculated from short axis cavity area (99SIEMENSUS, CA_LV_RadSAX)	Measurement Method: Left Ventricle Mass by Truncated Ellipse (DCM, 125222)
LV MASS T-E: d	Left Ventricle Truncated Semi-major Axis Diastolic Dimension (SRT, G-0378)	Measurement Method: Left Ventricle Mass by Truncated Ellipse (DCM, 125222)
LV MASS T-E: LV Mass	Left Ventricle Mass (LN, 18087-7)	Measurement Method: Left Ventricle Mass by Truncated Ellipse (DCM, 125222)
LV MASS T-E: LV Mass-l	Left Ventricle Mass (LN, 18087-7)	Index: Body Surface Area (LN, 8277-6) Measurement Method: Left Ventricle Mass by Truncated Ellipse (DCM, 125222)
LV MASS T-E: t	Myocardial Thickness calculated from short axis epicardial and cavity areas (99SIEMENSUS, CA_LV_MyoTh)	Measurement Method: Left Ventricle Mass by Truncated Ellipse (DCM, 125222)
Simpson BP: CI	Cardiac Index (SRT, F-32110)	Measurement Method: Method of Disks, Biplane (DCM, 125207)

Label (Heading: Measurement)	Code Meaning (Coding Scheme Designator, Code Value)	Modifiers
Simpson BP: CI2	Cardiac Index (SRT, F-32110)	Image View: Apical Two Chamber (SRT, G-A19B) Measurement Method: Method of Disks, Biplane (DCM, 125207)
Simpson BP: CI4	Cardiac Index (SRT, F-32110)	Image View: Apical Four Chamber (SRT, G-A19C) Measurement Method: Method of Disks, Biplane (DCM, 125207)
Simpson BP: CO	Cardiac Output (SRT, F-32100)	Measurement Method: Method of Disks, Biplane (DCM, 125207)
Simpson BP: CO2	Cardiac Output (SRT, F-32100)	Image View: Apical Two Chamber (SRT, G-A19B) Measurement Method: Method of Disks, Biplane (DCM, 125207)
Simpson BP: CO4	Cardiac Output (SRT, F-32100)	Image View: Apical Four Chamber (SRT, G-A19C) Measurement Method: Method of Disks, Biplane (DCM, 125207)
Simpson BP: difD	LV Difference (99SIEMENSUS, CA_LV_DIF)	Cardiac Cycle Point: End Diastole (SRT, F-32011) Measurement Method: Method of Disks, Biplane (DCM, 125207)
Simpson BP: difS	LV Difference (99SIEMENSUS, CA_LV_DIF)	Cardiac Cycle Point: F-32011, SRT, End Systole Measurement Method: Method of Disks, Biplane (DCM, 125207)
Simpson BP: EDV	Left Ventricular End Diastolic Volume (LN, 18026-5)	Measurement Method: Method of Disks, Biplane (DCM, 125207)
Simpson BP: EDV2	Left Ventricular End Diastolic Volume (LN, 18026-5)	Image View: Apical Two Chamber (SRT, G-A19B) Measurement Method: Method of Disks, Biplane (DCM, 125207)
Simpson BP: EDV4	Left Ventricular End Diastolic Volume (LN, 18026-5)	Image View: Apical Four Chamber (SRT, G-A19C) Measurement Method: Method of Disks, Biplane (DCM, 125207)
Simpson BP: EF	Left Ventricular Ejection Fraction (LN, 18043-0)	Measurement Method: Method of Disks, Biplane (DCM, 125207)
Simpson BP: EF2	Left Ventricular Ejection Fraction (LN, 18043-0)	Image View: Apical Two Chamber (SRT, G-A19B) Measurement Method: Method of Disks, Biplane (DCM, 125207)
Simpson BP: EF4	Left Ventricular Ejection Fraction (LN, 18043-0)	Image View: Apical Four Chamber (SRT, G-A19C) Measurement Method: Method of Disks, Biplane (DCM, 125207)
Simpson BP: ESV	Left Ventricular End Systolic Volume (LN, 18148-7)	Measurement Method: Method of Disks, Biplane (DCM, 125207)
Simpson BP: ESV2	Left Ventricular End Systolic Volume (LN, 18148-7)	Image View: Apical Two Chamber (SRT, G-A19B) Measurement Method: Method of Disks, Biplane (DCM, 125207)
Simpson BP: ESV4	Left Ventricular End Systolic Volume (LN, 18148-7)	Image View: Apical Four Chamber (SRT, G-A19C) Measurement Method: Method of Disks, Biplane (DCM, 125207)
Simpson BP: HR	Heart Rate (LN, 8867-4)	Measurement Method: Method of Disks, Biplane (DCM, 125207)
Simpson BP: SI	Stroke Index (SRT, F-00078)	Measurement Method: Method of Disks, Biplane (DCM, 125207)
Simpson BP: SI2	Stroke Index (SRT, F-00078)	Image View: Apical Two Chamber (SRT, G-A19B) Measurement Method: Method of Disks, Biplane (DCM, 125207)
Simpson BP: SI4	Stroke Index (SRT, F-00078)	Image View: Apical Four Chamber (SRT, G-A19C) Measurement Method: Method of Disks, Biplane (DCM, 125207)
Simpson BP: SV	Stroke Volume (SRT, F-32120)	Measurement Method: Method of Disks, Biplane (DCM, 125207)

Label (Heading: Measurement)	Code Meaning (Coding Scheme Designator, Code Value)	Modifiers
Simpson BP: SV2	Stroke Volume (SRT, F-32120)	Image View: Apical Two Chamber (SRT, G-A19B) Measurement Method: Method of Disks, Biplane (DCM, 125207)
Simpson BP: SV4	Stroke Volume (SRT, F-32120)	Image View: Apical Four Chamber (SRT, G-A19C) Measurement Method: Method of Disks, Biplane (DCM, 125207)
Simpson SP: CI	Cardiac Index (SRT, F-32110)	Image View: Apical Four Chamber (SRT, G-A19C) Measurement Method: Method of Disks, Single Plane (DCM, 125208)
Simpson SP: CO	Cardiac Output (SRT, F-32100)	Image View: Apical Four Chamber (SRT, G-A19C) Measurement Method: Method of Disks, Single Plane (DCM, 125208)
Simpson SP: EDV	Left Ventricular End Diastolic Volume (LN, 18026-5)	Image View: Apical Four Chamber (SRT, G-A19C) Measurement Method: Method of Disks, Single Plane (DCM, 125208)
Simpson SP: EF	Left Ventricular Ejection Fraction (LN, 18043-0)	Image View: Apical Four Chamber (SRT, G-A19C) Measurement Method: Method of Disks, Single Plane (DCM, 125208)
Simpson SP: ESV	Left Ventricular End Systolic Volume (LN, 18148-7)	Image View: Apical Four Chamber (SRT, G-A19C) Measurement Method: Method of Disks, Single Plane (DCM, 125208)
Simpson SP: HR	Heart Rate (LN, 8867-4)	Measurement Method: Method of Disks, Single Plane (DCM, 125208)
Simpson SP: SI	Stroke Index (SRT, F-00078)	Image View: Apical Four Chamber (SRT, G-A19C) Measurement Method: Method of Disks, Single Plane (DCM, 125208)
Simpson SP: SV	Stroke Volume (SRT, F-32120)	Image View: Apical Four Chamber (SRT, G-A19C) Measurement Method: Method of Disks, Single Plane (DCM, 125208)
Teichholz(2D): CI	Cardiac Index (SRT, F-32110)	Image Mode: 2D mode (SRT, G-03A2) Measurement Method: Teichholz (DCM, 125209)
Teichholz(2D): CO	Cardiac Output (SRT, F-32100)	Image Mode: 2D mode (SRT, G-03A2) Measurement Method: Teichholz (DCM, 125209)
Teichholz(2D): EDV	Left Ventricular End Diastolic Volume (LN, 18026-5)	Image Mode: 2D mode (SRT, G-03A2) Measurement Method: Teichholz (DCM, 125209)
Teichholz(2D): EF	Left Ventricular Ejection Fraction (LN, 18043-0)	Image Mode: 2D mode (SRT, G-03A2) Measurement Method: Teichholz (DCM, 125209)
Teichholz(2D): ESV	Left Ventricular End Systolic Volume (LN, 18148-7)	Image Mode: 2D mode (SRT, G-03A2) Measurement Method: Teichholz (DCM, 125209)

Label (Heading: Measurement)	Code Meaning (Coding Scheme Designator, Code Value)	Modifiers
Teichholz(2D): FS	Left Ventricular Fractional Shortening(LN, 18051-3)	Image Mode: 2D mode (SRT, G-03A2) Measurement Method: Teichholz (DCM, 125209)
Teichholz(2D): HR	Heart Rate (LN, 8867-4)	Image Mode: 2D mode (SRT, G-03A2) Measurement Method: Teichholz (DCM, 125209)
Teichholz(2D): IVSd	Interventricular Septum Diastolic Thickness (LN, 18154-5)	Image Mode: 2D mode (SRT, G-03A2) Measurement Method: Teichholz (DCM, 125209)
Teichholz(2D): IVSs	Interventricular Septum Systolic Thickness (LN, 18158-6)	Image Mode: 2D mode (SRT, G-03A2) Measurement Method: Teichholz (DCM, 125209)
Teichholz(2D): LVIDd	Left Ventricle Internal End Diastolic Dimension (LN, 29436-3)	Image Mode: 2D mode (SRT, G-03A2) Measurement Method: Teichholz (DCM, 125209)
Teichholz(2D): LVIDs	Left Ventricle Internal Systolic Dimension (LN, 29438-9)	Image Mode: 2D mode (SRT, G-03A2) Measurement Method: Teichholz (DCM, 125209)
Teichholz(2D): LVPWd	Left Ventricle Posterior Wall Diastolic Thickness (LN, 18152-9)	Image Mode: 2D mode (SRT, G-03A2) Measurement Method: Teichholz (DCM, 125209)
Teichholz(2D): LVPWs	Left Ventricle Posterior Wall Systolic Thickness (LN, 18156-0)	Image Mode: 2D mode (SRT, G-03A2) Measurement Method: Teichholz (DCM, 125209)
Teichholz(2D): SI	Stroke Index (SRT, F-00078)	Image Mode: 2D mode (SRT, G-03A2) Measurement Method: Teichholz (DCM, 125209)
Teichholz(2D): SV	Stroke Volume (SRT, F-32120)	Image Mode: 2D mode (SRT, G-03A2) Measurement Method: Teichholz (DCM, 125209)

### 13.2 Right Ventricle

Label (Heading: Measurement)	Code Meaning (Coding Scheme Designator, Code Value)	Modifiers
<b>Right Ventricle</b>	Finding Site: Right Ventricle (SRT, T-32500)	
AV/LA(2D): RV diam	Right Ventricular Internal Diastolic Dimension at AV/LA (99SIEMENSUS, CA_RV_INTDIA_AV2LA)	Image Mode: 2D mode (SRT, G-03A2)
AV/LA(M): RV diam	Right Ventricular Internal Diastolic Dimension at AV/LA (99SIEMENSUS, CA_RV_INTDIA_AV2LA)	Image Mode: M-Mode (SRT, G-0394)
Cubed(2D): RVAWd	Right Ventricle Anterior Wall Diastolic Thickness (LN, 18153-7)	Image Mode: 2D mode (SRT, G-03A2) Measurement Method: Cube Method (DCM, 125206)
Cubed(2D): RVDd	Right Ventricular Internal Diastolic Dimension (LN, 20304-2)	Image Mode: 2D mode (SRT, G-03A2) Measurement Method: Cube Method (DCM, 125206)
LV/Cubed(M): RVDd	Right Ventricular Internal Diastolic Dimension (LN, 20304-2)	Image Mode: M-Mode (SRT, G-0394) Measurement Method: Cube Method (DCM, 125206)

Label (Heading: Measurement)	Code Meaning (Coding Scheme Designator, Code Value)	Modifiers
LV/Teichholz(M): RVDd	Right Ventricular Internal Diastolic Dimension (LN, 20304-2)	Image Mode: M-Mode (SRT, G-0394) Measurement Method: Teichholz (DCM, 125209)
Pulmonary Valve: CI	Cardiac Index (SRT, F-32110)	Finding Site: Right Ventricle Outflow Tract (SRT, T-32550) Measurement Method: Doppler Volume Flow (DCM, 125219)
Pulmonary Valve: CO	Cardiac Output (SRT, F-32100)	Finding Site: Right Ventricle Outflow Tract (SRT, T-32550) Measurement Method: Doppler Volume Flow (DCM, 125219)
Pulmonary Valve: RVOT diam	Cardiovascular Orifice Diameter (SRT, G-038F)	Finding Site: Right Ventricle Outflow Tract (SRT, T-32550) Image Mode: 2D mode (SRT, G-03A2)
Pulmonary Valve: SI	Stroke Index (SRT, F-00078)	Finding Site: Right Ventricle Outflow Tract (SRT, T-32550) Measurement Method: Doppler Volume Flow (DCM, 125219)
Pulmonary Valve: SV	Stroke Volume (SRT, F-32120)	Finding Site: Right Ventricle Outflow Tract (SRT, T-32550) Measurement Method: Doppler Volume Flow (DCM, 125219)
RV: RV diam [for 2D and M-Mode]	Right Ventricular Internal Diastolic Dimension (LN, 20304-2)	
Teichholz(2D): RVAWd	Right Ventricle Anterior Wall Diastolic Thickness (LN, 18153-7)	Image Mode: 2D mode (SRT, G-03A2) Measurement Method: Teichholz (DCM, 125209)
Teichholz(2D): RVDd	Right Ventricular Internal Diastolic Dimension (LN, 20304-2)	Image Mode: 2D mode (SRT, G-03A2) Measurement Method: Teichholz (DCM, 125209)
TR: RVSP	Right Ventricular Peak Systolic Pressure (SRT, G-0380)	
Tricuspid Valve: RVIMP	Right Ventricular Index of Myocardial Performance (SRT, G-0381)	

### 13.3 Left Atrium

Label (Heading: Measurement)	Code Meaning (Coding Scheme Designator, Code Value)	Modifiers
<b>Left Atrium</b>	Finding Site: Left Atrium (SRT, T-32300)	
AV/LA(2D): LA diam	Left Atrium Antero-posterior Systolic Dimension (LN, 29469-4)	Image Mode: 2D mode (SRT, G-03A2)
AV/LA(M): LA diam	Left Atrium Antero-posterior Systolic Dimension (LN, 29469-4)	Image Mode: M-Mode (SRT, G-0394)

### 13.4 Right Atrium

Label (Heading: Measurement)	Code Meaning (Coding Scheme Designator, Code Value)	Modifiers
<b>Right Atrium</b>	Finding Site: Right Atrium (SRT, T-32200)	
PR: RAP TR: RAP or not shown on report	Right Atrium Systolic Pressure (LN, 18070-3)	

### 13.5 Aortic Valve

Label (Heading: Measurement)	Code Meaning (Coding Scheme Designator, Code Value)	Modifiers
<b>Aortic Valve</b>	Finding Site: Aortic Valve (SRT, T-35400)	
Aortic Valve: AV PGmax	Peak Gradient (LN, 20247-3)	Direction of Flow: Antegrade Flow (SRT, R-42047)
Aortic Valve: AV PGmean	Mean Gradient (LN, 20256-4)	Direction of Flow: Antegrade Flow (SRT, R-42047)
Aortic Valve: AV Vmax	Peak Systolic Velocity (LN, 11726-7)	Direction of Flow: Antegrade Flow (SRT, R-42047)
Aortic Valve: AV Vmean	Mean Velocity (LN, 20352-1)	Direction of Flow: Antegrade Flow (SRT, R-42047)
Aortic Valve: AV VTI	Velocity Time Integral (LN, 20354-7)	Direction of Flow: Antegrade Flow (SRT, R-42047)
Aortic Valve: AVA(Trace)	Cardiovascular Orifice Area (SRT, G-038E)	Image Mode: 2D mode (SRT, G-03A2) Measurement Method: Planimetry (DCM, 125220)
Aortic Valve: AVA(Vmax)	Cardiovascular Orifice Area (SRT, G-038E)	Direction of Flow: Antegrade Flow (SRT, R-42047) Measurement Method: Continuity Equation by Peak Velocity (DCM, 125214);
Aortic Valve: AVA(VTI)	Cardiovascular Orifice Area (SRT, G-038E)	Direction of Flow: Antegrade Flow (SRT, R-42047) Measurement Method: Continuity Equation by Velocity Time Integral (DCM, 125215)
Aortic Valve: HR	Heart Rate (LN, 8867-4)	Finding Site: Aortic Valve (SRT, T-35400)
Aortic Valve: LVET	Aortic Valve Ejection Time (LN, 18041-4)	Image Mode: Doppler Mode (99SIEMENSUS, DOPPLER)
Aortic Valve: LVPEP	Pre-Ejection Period (LN, 18068-7)	
Aortic Valve: LVSTI	Aortic Valve Pre-ejection Period to Ejection Time (99SIEMENSUS, CA-AV_PEP2ET)	Image Mode: Doppler Mode (99SIEMENSUS, DOPPLER)
AR: AI Dec Slope	Deceleration Slope (LN, 20216-8)	Direction of Flow: Regurgitant Flow (SRT, R-42E61) Measurement Method: Area by Pressure Half-Time (DCM, 125210)
AR: AI Dec Time	Deceleration Time (LN, 20217-6)	Direction of Flow: Regurgitant Flow (SRT, R-42E61) Measurement Method: Area by Pressure Half-Time (DCM, 125210)
AR: AI PGmax	Peak Gradient (LN, 20247-3)	Direction of Flow: Regurgitant Flow (SRT, R-42E61) Measurement Method: Area by Pressure Half-Time (DCM, 125210)
AR: AI PHT	Pressure Half-Time (LN, 20280-4)	Direction of Flow: Regurgitant Flow (SRT, R-42E61) Measurement Method: Area by Pressure Half-Time (DCM, 125210)

Label (Heading: Measurement)	Code Meaning (Coding Scheme Designator, Code Value)	Modifiers
AR: AI Vmax	Maximum Velocity (LN, 20351-3)	Direction of Flow: Regurgitant Flow (SRT, R-42E61) Measurement Method: Area by Pressure Half-Time (DCM, 125210)
AR: AR PGmax	Peak Gradient (LN, 20247-3)	Direction of Flow: Regurgitant Flow (SRT, R-42E61)
AR: AR Time	Aortic Valve Regurgitant Diastolic Deceleration Time (LN, 17998-6)	
AR: AR V ed	End Diastolic Velocity (LN, 11653-3)	Direction of Flow: Regurgitant Flow (SRT, R-42E61)
AR: AR Vmax	Maximum Velocity (LN, 20351-3)	Direction of Flow: Regurgitant Flow (SRT, R-42E61)
AR: Decel Rate	Deceleration Slope (LN, 20216-8)	Direction of Flow: Regurgitant Flow (SRT, R-42E61)
AV/LA(2D): ACS	Aortic Valve Cusp Separation (LN, 17996-0)	Image Mode: 2D mode (SRT, G-03A2)
AV/LA(2D): AO/LA	Aortic Root Diameter to Left Atrium Diameter Ratio (99SIEMENSUS, CA_LA_AO2LA)	Image Mode: 2D mode (SRT, G-03A2)
AV/LA(M): ACS	Aortic Valve Cusp Separation (LN, 17996-0)	Image Mode: M-Mode (SRT, G-0394)
AV/LA(M): AO/LA	Aortic Root Diameter to Left Atrium Diameter Ratio (99SIEMENSUS, CA_LA_AO2LA)	Image Mode: M-Mode (SRT, G-0394)
AV/LA(2D): LVET AV/LA(M): LVET	Aortic Valve Ejection Time (LN, 18041-4)	Image Mode: M-Mode (SRT, G-0394)
AV/LA(2D): LVPEP AV/LA(M): LVPEP	Pre-Ejection Period (LN, 18068-7)	Image Mode: M-Mode (SRT, G-0394)
AV/LA(2D): LVSTI AV/LA(M): LVSTI	Aortic Valve Pre-ejection Period to Ejection Time (99SIEMENSUS, CA-AV_PEP2ET)	Image Mode: M-Mode (SRT, G-0394)
LV/Teichholz(M): LVET	Aortic Valve Ejection Time (LN, 18041-4)	Image Mode: M-Mode (SRT, G-0394) Measurement Method: Teichholz (DCM, 125209)
LV/Cubed(M): LVET	Aortic Valve Ejection Time (LN, 18041-4)	Image Mode: M-Mode (SRT, G-0394) Measurement Method: Cube Method (DCM, 125206)

### 13.6 Mitral Valve

Label (Heading: Measurement)	Code Meaning (Coding Scheme Designator, Code Value)	Modifiers
<b>Mitral Valve</b>	Finding Site: Mitral Valve (SRT, T-35300)	
Mitral Valve: A/E	Mitral Valve A to E Ratio (99SIEMENSUS, CA_MV_A2E)	
Mitral Valve: A duration	Mitral Valve A-Wave Duration (SRT, G-0385)	
Mitral Valve: CA/CE	Mitral Valve A to E Ratio (99SIEMENSUS, CA_MV_A2E)	Image Mode: M-Mode (SRT, G-0394)
Mitral Valve: CA amp	Amplitude A Wave Mmode (99SIEMENSUS, CA_MV_AwaveAmpl)	Image Mode: M-Mode (SRT, G-0394)

Label (Heading: Measurement)	Code Meaning (Coding Scheme Designator, Code Value)	Modifiers
Mitral Valve: CE amp	Amplitude E Wave Mmode (99SIEMENSUS, CA_MV_EwaveAmpl)	Image Mode: M-Mode (SRT, G-0394)
Mitral Valve: CI	Cardiac Index (SRT, F-32110)	Image Mode: Doppler Mode (99SIEMENSUS, DOPPLER) Measurement Method: Doppler Volume Flow (DCM, 125219)
Mitral Valve: DE amp	Amplitude D-E Wave Mmode (99SIEMENSUS, CA_MV_DEWaveAmpl)	Image Mode: M-Mode (SRT, G-0394)
Mitral Valve: DE excursion	Mitral Valve D-E Excursion (LN, 17997-8)	Image Mode: M-Mode (SRT, G-0394)
Mitral Valve: Dec Slope	Deceleration Slope (LN, 20216-8)	Image Mode: Doppler Mode (99SIEMENSUS, DOPPLER)
Mitral Valve: Dec Time	Mitral Valve E-Wave Deceleration Time (SRT, G-0384)	
Mitral Valve: E/A	Mitral Valve E to A Ratio (LN, 18038-0)	Image Mode: Doppler Mode (99SIEMENSUS, DOPPLER)
Mitral Valve: E duration	Mitral Valve E-Wave Duration (99SIEMENSUS, CA_MV_DURe)	
Mitral Valve: EF slope	Mitral Valve E-F Slope by M-Mode (LN, 18040-6)	Image Mode: M-Mode (SRT, G-0394)
Mitral Valve: EPSS	Mitral Valve EPSS, E wave (LN, 18036-4)	Image Mode: 2D mode (SRT, G-03A2)
Mitral Valve: EPSS	Mitral Valve EPSS, E wave (LN, 18036-4)	Image Mode: M-Mode (SRT, G-0394)
Mitral Valve: HR	Heart Rate (LN, 8867-4)	
Mitral Valve: MV A pt	Mitral Valve A-Wave Peak Velocity (LN, 17978-8)	
Mitral Valve: MV C-Odur	Mitral Valve Closure to Opening Time (SRT, G-0387)	
Mitral Valve: MV diam	Cardiovascular Orifice Diameter (SRT, G-038F)	
Mitral Valve: MV E pt	Mitral Valve E-Wave Peak Velocity (LN, 18037-2)	
Mitral Valve: MV LVET	Aortic Valve Ejection Time (LN, 18041-4)	Image Mode: Doppler Mode (99SIEMENSUS, DOPPLER)
Mitral Valve: MV PGmax	Mitral Valve Diastolic Peak Instantaneous Gradient (LN, 18057-0)	
Mitral Valve: MV PGmean	Mean Gradient (LN, 20256-4)	Direction of Flow: Antegrade Flow (SRT, R-42047)
Mitral Valve: MV PHT	Pressure Half-Time (LN, 20280-4)	Direction of Flow: Antegrade Flow (SRT, R-42047)
Mitral Valve: MV Vmax	Maximum Velocity (LN, 20351-3)	Direction of Flow: Antegrade Flow (SRT, R-42047)
Mitral Valve: MV Vmean	Mean Velocity (LN, 20352-1)	Direction of Flow: Antegrade Flow (SRT, R-42047)
Mitral Valve: MV VTI	Velocity Time Integral (LN, 20354-7)	Direction of Flow: Antegrade Flow (SRT, R-42047)
Mitral Valve: MVA(PHT)	Cardiovascular Orifice Area (SRT, G-038E)	Image Mode: Doppler Mode (99SIEMENSUS, DOPPLER) Direction of Flow: Antegrade Flow (SRT, R-42047) Measurement Method: Area by Pressure Half-Time (DCM, 125210)
Mitral Valve: MVA(Trace)	Cardiovascular Orifice Area (SRT, G-038E)	Image Mode: 2D mode (SRT, G-03A2) Measurement Method: Planimetry (DCM, 125220);
Mitral Valve: MVA(VTI)	Cardiovascular Orifice Area (SRT, G-038E)	Image Mode: Doppler Mode (99SIEMENSUS, DOPPLER) Direction of Flow: Antegrade Flow (SRT, R-42047) Measurement Method: Continuity Equation (DCM, 125212)

Label (Heading: Measurement)	Code Meaning (Coding Scheme Designator, Code Value)	Modifiers
Mitral Valve: SI	Stroke Index (SRT, F-00078)	Image Mode: Doppler Mode (99SIEMENSUS, DOPPLER)
MR: dP/dt	Mitral Regurgitation dP/dt derived from Mitral Regurgitation Velocity (LN, 18035-6)	
MR: dt	Deceleration Time (LN, 20217-6)	Direction of Flow: Regurgitant Flow (SRT, R-42E61)
MR: MR PGmax	Peak Gradient (LN, 20247-3)	Direction of Flow: Regurgitant Flow (SRT, R-42E61)
MR: MR Vmax	Peak Systolic Velocity (LN, 11726-7)	Direction of Flow: Regurgitant Flow (SRT, R-42E61)
PISA(MR): Aliasing Vel	Mean Velocity (LN, 20252-1)	Direction of Flow: Regurgitant Flow (SRT, R-42E61) Measurement Method: Proximal Isovelocity Surface Area (DCM, 125216) Derivation: Estimated (DCM, 121427)
PISA(MR): EO Area	Cardiovascular Orifice Area (SRT, G-038E)	Image Mode: Doppler Mode (99SIEMENSUS, DOPPLER) Direction of Flow: Regurgitant Flow (SRT, R-42E61) Measurement Method: Proximal Isovelocity Surface Area (DCM, 125216)
PISA(MR): Flow Rate	Peak Instantaneous Flow Rate (LN, 34141-2)	Direction of Flow: Regurgitant Flow (SRT, R-42E61) Measurement Method: Proximal Isovelocity Surface Area (DCM, 125216)
PISA(MR): Flow Vol	Volume Flow (LN, 33878-0)	Direction of Flow: Regurgitant Flow (SRT, R-42E61) Measurement Method: Proximal Isovelocity Surface Area (DCM, 125216)
PISA(MR): MR Vmax	Peak Systolic Velocity (LN, 11726-7)	Direction of Flow: Regurgitant Flow (SRT, R-42E61) Measurement Method: Proximal Isovelocity Surface Area (DCM, 125216)
PISA(MR): MR VTI	Velocity Time Integral (LN, 20354-7)	Direction of Flow: Regurgitant Flow (SRT, R-42E61) Measurement Method: Proximal Isovelocity Surface Area (DCM, 125216)
PISA(MR): Radius	Dome Radius (99SIEMENSUS, CA_DOME)	Direction of Flow: Regurgitant Flow (SRT, R-42E61) Measurement Method: Proximal Isovelocity Surface Area (DCM, 125216)
PISA(MS): Aliasing Vel	Mean Velocity (LN, 20252-1)	Direction of Flow: Antegrade Flow (SRT, R-42047) Measurement Method: Proximal Isovelocity Surface Area (DCM, 125216) Derivation: Estimated (DCM, 121427)
PISA(MS): Angle	Angle measured at Mitral Valve Stenosis (99SIEMENSUS, CA_MS_Angle)	Direction of Flow: Antegrade Flow (SRT, R-42047) Measurement Method: Proximal Isovelocity Surface Area (DCM, 125216)

Label (Heading: Measurement)	Code Meaning (Coding Scheme Designator, Code Value)	Modifiers
PISA(MS): Flow Rate	Peak Instantaneous Flow Rate (LN, 34141-2)	Direction of Flow: Antegrade Flow (SRT, R-42047) Measurement Method: Proximal Isovelocity Surface Area (DCM, 125216)
PISA(MS): Flow Vol	Volume Flow (LN, 33878-0)	Direction of Flow: Antegrade Flow (SRT, R-42047) Measurement Method: Proximal Isovelocity Surface Area (DCM, 125216)
PISA(MS): MS PGmax	Peak Gradient (LN, 20247-3)	Direction of Flow: Antegrade Flow (SRT, R-42047) Measurement Method: Proximal Isovelocity Surface Area (DCM, 125216)
PISA(MS): MS Vmax	Maximum Velocity (LN, 20351-3)	Direction of Flow: Antegrade Flow (SRT, R-42047) Measurement Method: Proximal Isovelocity Surface Area (DCM, 125216)
PISA(MS): MS VTI	Velocity Time Integral (LN, 20354-7)	Direction of Flow: Antegrade Flow (SRT, R-42047) Measurement Method: Proximal Isovelocity Surface Area (DCM, 125216)
PISA(MS): MS MVA	Cardiovascular Orifice Area (SRT, G-038E)	Image Mode: Doppler Mode (99SIEMENSUS, DOPPLER) Direction of Flow: Antegrade Flow (SRT, R-42047) Measurement Method: Proximal Isovelocity Surface Area (DCM, 125216)
PISA(MS): Radius	Dome Radius (99SIEMENSUS, CA_DOME)	Direction of Flow: Antegrade Flow (SRT, R-42047) Measurement Method: Proximal Isovelocity Surface Area (DCM, 125216)

### 13.7 Pulmonic Valve

Label (Heading: Measurement)	Code Meaning (Coding Scheme Designator, Code Value)	Modifiers
<b>Pulmonic Valve</b>	Finding Site: Pulmonic Valve (SRT, T-35200)	
PR: PR PGmax	Peak Gradient (LN, 20247-3)	Direction of Flow: Regurgitant Flow (SRT, R-42E61)
PR: PR PGmean	Mean Gradient (LN, 20256-4)	Direction of Flow: Regurgitant Flow (SRT, R-42E61)
PR: PR Ved	End Diastolic Velocity (LN, 11653-3)	Direction of Flow: Regurgitant Flow (SRT, R-42E61)
PR: PR Vmax	Maximum Velocity (LN, 20351-3)	Direction of Flow: Regurgitant Flow (SRT, R-42E61)
PR: PR Vmean	Mean Velocity (LN, 20352-1)	Direction of Flow: Regurgitant Flow (SRT, R-42E61)
PR: PR VTI	Velocity Time Integral (LN, 20354-7)	Direction of Flow: Regurgitant Flow (SRT, R-42E61)
Pulmonary Valve: HR	Heart Rate (LN, 8867-4)	
Pulmonary Valve: PV PGmax	Peak Gradient (LN, 20247-3)	Direction of Flow: Antegrade Flow (SRT, R-42047)
Pulmonary Valve: PV PGmean	Mean Gradient (LN, 20256-4)	Direction of Flow: Antegrade Flow (SRT, R-42047)

Label (Heading: Measurement)	Code Meaning (Coding Scheme Designator, Code Value)	Modifiers
Pulmonary Valve: PV Vmax	Peak Systolic Velocity (LN, 11726-7)	Direction of Flow: Antegrade Flow (SRT, R-42047)
Pulmonary Valve: PV Vmean	Mean Velocity (LN, 20352-1)	Direction of Flow: Antegrade Flow (SRT, R-42047)
Pulmonary Valve: RV Acc T/ET	Ratio of Pulmonic Valve Acceleration Time to Ejection Time (SRT, G-0388)	Direction of Flow: Antegrade Flow (SRT, R-42047)
Pulmonary Valve: RV Acc Time	Acceleration Time (LN, 20168-1)	Direction of Flow: Antegrade Flow (SRT, R-42047)
Pulmonary Valve: RVET Tricuspid Valve: RVET	Pulmonic Valve Ejection Time (LN, 18042-2)	
Pulmonary Valve: RVOT VTI	Velocity Time Integral (LN, 20354-7)	Direction of Flow: Antegrade Flow (SRT, R-42047)
Pulmonary Valve: RVPEP	Right Ventricle Pre-Ejection Period (LN, 20301-8)	Image Mode: M-Mode (SRT, G-0394)
Pulmonary Valve: RVSTI	Pulmonic Valve Pre-ejection Period to Ejection Time (99SIEMENSUS, CA_PV_PEP2ET)	Image Mode: Doppler Mode (99SIEMENSUS, DOPPLER)

### 13.8 Tricuspid Valve

Label (Heading: Measurement)	Code Meaning (Coding Scheme Designator, Code Value)	Modifiers
<b>Tricuspid Valve</b>	Finding Site: Tricuspid Valve (SRT, T-35100)	
TR: TR PGmax	Peak Gradient (LN, 20247-3)	Direction of Flow: Regurgitant Flow (SRT, R-42E61)
TR: TR PGmean	Mean Gradient (LN, 20256-4)	Direction of Flow: Regurgitant Flow (SRT, R-42E61)
TR: TR Vmax	Peak Systolic Velocity (LN, 11726-7)	Direction of Flow: Regurgitant Flow (SRT, R-42E61)
TR: TR Vmean	Mean Velocity (LN, 20352-1)	Direction of Flow: Regurgitant Flow (SRT, R-42E61)
TR: TR VTI	Velocity Time Integral (LN, 20354-7)	Direction of Flow: Regurgitant Flow (SRT, R-42E61)
Tricuspid Valve: E/A	Tricuspid Valve E to A Ratio (LN, 18039-8)	Direction of Flow: Antegrade Flow (SRT, R-42047)
Tricuspid Valve: TV A pt	Tricuspid Valve A Wave Peak Velocity (LN, 18030-7)	Direction of Flow: Antegrade Flow (SRT, R-42047)
Tricuspid Valve: TV C-Odur	Tricuspid Valve Closure to Opening Time (SRT, G-0389)	
Tricuspid Valve: TV E pt	Tricuspid Valve E Wave Peak Velocity (LN, 18031-5)	Direction of Flow: Antegrade Flow (SRT, R-42047)
Tricuspid Valve: TV PGmax	Peak Gradient (LN, 20247-3)	Direction of Flow: Antegrade Flow (SRT, R-42047)
Tricuspid Valve: TV PGmean	Mean Gradient (LN, 20256-4)	Direction of Flow: Antegrade Flow (SRT, R-42047)
Tricuspid Valve: TV Vmax	Maximum Velocity (LN, 20351-3)	Direction of Flow: Antegrade Flow (SRT, R-42047)
Tricuspid Valve: TV Vmean	Mean Velocity (LN, 20352-1)	Direction of Flow: Antegrade Flow (SRT, R-42047)
Tricuspid Valve: TV VTI	Velocity Time Integral (LN, 20354-7)	Direction of Flow: Antegrade Flow (SRT, R-42047)

**13.9 Aorta**

Label (Heading: Measurement)	Code Meaning (Coding Scheme Designator, Code Value)	Modifiers
<b>Aorta</b>	Finding Site: Aorta (SRT, T-42000)	
AV/LA(2D): AO	Aortic Root Diameter (LN, 18015-8)	Image Mode: 2D mode (SRT, G-03A2) Cardiac Cycle Point: Systole (SRT, F-32020)
AV/LA(M): AO	Aortic Root Diameter (LN, 18015-8)	Image Mode: M-Mode (SRT, G-0394) Cardiac Cycle Point: Systole (SRT, F-32020)

**13.10 Pulmonary Artery**

Label (Heading: Measurement)	Code Meaning (Coding Scheme Designator, Code Value)	Modifiers
<b>Pulmonary Artery</b>	Finding Site: Pulmonary Artery (SRT, T-44000)	
PR: PAEDP	Pulmonary Artery Pressure (SRT, F-0212C)	Cardiac Cycle Point: End Diastole (SRT, F-32011)
Pulmonary Valve: PA Acc Time	Acceleration Time (LN, 20168-1)	Direction of Flow: Antegrade Flow (SRT, R-42047)

**13.11 Pulmonary Venous Structure**

Label (Heading: Measurement)	Code Meaning (Coding Scheme Designator, Code Value)	Modifiers
<b>Pulmonary Venous Structure</b>	Finding Site: Pulmonary Venous Structure (SRT, T-48581)	
Pulmonary Vein: PVa Dur	Pulmonary Vein A-Wave Duration (SRT, G-038B)	
Pulmonary Vein: PVa Vel	Pulmonary Vein Atrial Contraction Reversal Peak Velocity (LN, 29453-8)	Cardiac Cycle Point: Diastole (SRT, F-32010)
Pulmonary Vein: PVd Decel T	Deceleration Time (LN, 20217-6)	Cardiac Cycle Point: Diastole (SRT, F-32010)
Pulmonary Vein: PVd Vel	Pulmonary Vein Diastolic Peak Velocity (LN, 29451-2)	Cardiac Cycle Point: Diastole (SRT, F-32010)
Pulmonary Vein: PVd VTI	Pulmonary Vein D-Wave Velocity Time Integral (SRT, G-038D)	
Pulmonary Vein: PVs VTI	Pulmonary Vein S-Wave Velocity Time Integral (SRT, G-038C)	
Pulmonary Vein: PVs1 Vel	Pulmonary Vein Systolic Peak Velocity (LN, 29450-4)	Topographical Modifier: Peak1 (99SIEME, Peak1)
Pulmonary Vein: PVs2/PVd	Pulmonary Vein Systolic to Diastolic Ratio (LN, 29452-0)	
Pulmonary Vein: PVs2 Vel	Pulmonary Vein Systolic Peak Velocity (LN, 29450-4)	Topographical Modifier: Peak2 (99SIEME, Peak2)
Pulmonary Vein: Sys Fraction	Pulmonary Vein Systolic Fraction (99SIEMENSUS, CA_PVE_SF)	