

Siemens Medical Solutions  
Ultrasound Division

**ACUSON Sequoia™ Ultrasound System**  
DICOM Conformance Statement  
**Sequoia 8.0**

---

---

**Revision Data**

<b>Revision</b>	<b>Description</b>	<b>Date</b>
15	Updated for Sequoia 8.0	7/12/04

<b>1. Purpose</b> .....	<b>4</b>
1.1 Scope .....	4
<b>2. Implementation Model</b> .....	<b>4</b>
2.1 Application Data Flow Diagram .....	5
2.1.1 Verification.....	6
2.1.2 Image Export.....	6
2.1.3 Image Print .....	7
2.1.4 Modality Worklist .....	8
2.1.5 Modality Performed Procedure Step .....	10
2.1.6 Storage Commitment .....	10
2.1.7 DICOM MOD Media Interchange .....	11
2.2 AE Functional Definition .....	13
2.2.1 Verification Real-World Activities.....	13
2.2.2 Image Export Real-World Activities .....	13
2.2.3 Image Print Real-World Activities .....	13
2.2.4 Modality Worklist Real-World Activities .....	13
2.2.5 Modality Performed Procedure Step Real-World Activities.....	13
2.2.6 Storage Commitment Real-World Activities.....	13
2.2.7 DICOM MOD Media Interchange Real-World Activities .....	13
<b>3. AE Specifications</b> .....	<b>14</b>
3.1 Sequoia AE Specification .....	14
3.1.1 Association Establishment Policies .....	14
3.1.1.1 General .....	14
3.1.1.2 Number of Associations .....	14
3.1.1.3 Asynchronous Nature.....	15
3.1.1.4 Implementation Identifying Information.....	15
3.1.1.5 Calling and Called AE Titles.....	15
3.1.2 Association Initiation by Real-World Activities .....	15
3.1.2.1 Real World Activity – Verification .....	15
3.1.2.1.1. Proposed Presentation Contexts – Verification.....	15
3.1.2.2 Real World Activity – Store.....	16
3.1.2.2.1. Proposed Presentation Context .....	16
3.1.2.2.2. Photometric Interpretation.....	17
3.1.2.2.3. Storage SOP Classes: DICOM IOD Specification.....	18
3.1.2.3 Real World Activity – Print.....	24
3.1.2.3.1. Proposed Presentation Context to a Grayscale Printer.....	25
3.1.2.3.2. Printer SOP Class .....	25
3.1.2.3.3. Basic Film Session SOP Class .....	26
3.1.2.3.4. Basic Film Box SOP Class.....	26
3.1.2.3.5. Basic Film Grayscale Image Box SOP Class.....	27
3.1.2.3.6. Proposed Presentation Context to a Color Printer .....	28
3.1.2.3.7. Basic Film Color Image Box SOP Class .....	28
3.1.2.4 Real World Activity – Worklist .....	29
3.1.2.4.1. Proposed Presentation Context .....	29
3.1.2.4.2. Modality Worklist Service SOP Class.....	29

3.1.2.5	Real World Activity – Modality Performed Procedure Step .....	32
3.1.2.5.1.	Proposed Presentation Context .....	32
3.1.2.5.2.	Modality Performed Procedure Step Service SOP Class .....	32
3.1.2.6	Real World Activity – Storage Commitment .....	34
3.1.2.6.1.	Proposed Presentation Context .....	34
3.1.2.6.2.	Storage Commitment Service SOP Class .....	34
3.1.2.7	Real World Activity – MOD Media Interchange .....	35
3.1.2.7.1.	Ultrasound Application Profile .....	35
3.1.2.7.2.	Proposed Presentation Context .....	36
<b>4.</b>	<b>Communication Profiles .....</b>	<b>36</b>
4.1	TCP/IP Stack Supported .....	36
4.2	Physical Media Supported .....	36
<b>5.</b>	<b>Data Identification Information .....</b>	<b>36</b>
<b>6.</b>	<b>Extensions, Specializations and Privatizations .....</b>	<b>37</b>
6.1	Private DICOM Elements .....	37
<b>7.</b>	<b>Configuration .....</b>	<b>37</b>
<b>8.</b>	<b>Support of Extended Character Sets .....</b>	<b>38</b>
<b>9.</b>	<b>References .....</b>	<b>38</b>
<b>10.</b>	<b>Glossary .....</b>	<b>38</b>

## 1. Purpose

This document describes the conformance to the ACR\_NEMA DICOM 3.0 Standard by the Acuson Sequoia™ ultrasound system release 8.0 from Siemens Medical Solutions, Ultrasound Division. It shall establish the conformance specifications for this system only, and does not apply to other products offered by Siemens Medical Solutions.

The Sequoia system is a device that generates ultrasound images and other data that can be set using DICOM standard protocols and definitions to other DICOM compliant devices including any DICOM compliant devices that support SOP classes as defined in Figure 2.1-2 in this document.

### 1.1 Scope

The DICOM standard provides a well-defined set of structures and protocols that allow inter-operability of a wide variety of medical imaging devices.

When configured with the DICOM option, the Sequoia system provides support for essential services related to ultrasound scanning and connectivity to DICOM compliant devices. The Sequoia system will not support all features supported by the DICOM standard. This document clearly states the DICOM services and data classes that are supported by the applications included with the Sequoia system. The intent of this document is to allow users and other vendors who also conform to the DICOM standard to exchange information within the specific context of those elements of the DICOM standard that the Sequoia system supports.

This document is written with respect to the adopted portions of the DICOM standard, Revision 3.0. The following sections of this document follow the outline specified in the DICOM Standard NEMA publication PS3.2.<sup>1</sup>

## 2. Implementation Model

Sequoia system users can store images and other data directly on the Sequoia system hard disk. Images can be exported to a DICOM archive server or workstation on a network, and in addition to MO disk media. Storage Commitment is implemented as a “push” model only. The user is capable of querying a DICOM Worklist server for a list of scheduled patient procedures, as well as supporting a Modality Performed Procedure Step (MPPS) server. Printing of images to DICOM printers is also supported. In the following sections, the Sequoia system real world activities are indicated by “Real World Activity” name while “SEQUOIA AE” indicates the invoked Application Entity. Similarly, the activities associated with service providers are indicated as “Real World Service Activity”.

---

<sup>1</sup> Second part of the DICOM standard: NEMA Standards Publication PS 3.2-1998, Digital Imaging and Communications in Medicine (DICOM), Part 2: Conformance

## 2.1 Application Data Flow Diagram

Figure 2.1-1 illustrates the Implementation Model of the Sequoia system. The Sequoia system's Application Entity (AE) is shown in the box. Relationships between the user invoked activities (in the circles at the left of the AE) and the associated real-world activities provided by DICOM service providers (in the circles on the right side of the diagram) are shown.

Figure 2.1-1 Implementation Model

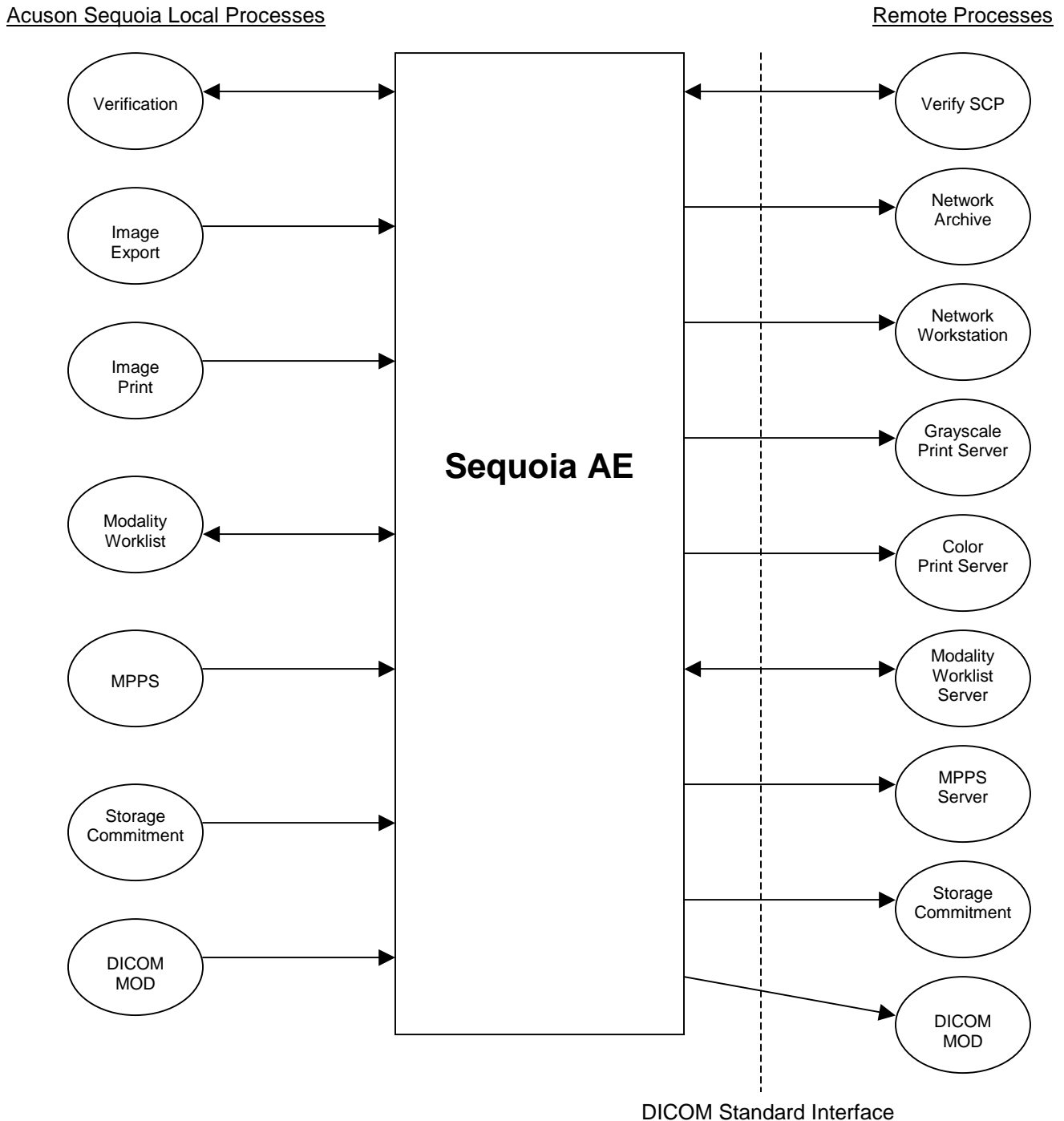

## 2.1.1 Verification

Verification is a part of the “Service UI – Network Setup” menu located in the Sequoia System Setup Menu. Verification can be used to send a DICOM verification request (Echo) to a remote Application Entity (AE) and will listen for a response. Verification on Sequoia can be done as an SCU or an SCP.

When Verification is used, the following messages are returned to the user:

1. dicomPing result = SUCCESS
2. dicomPing result = FAILED

Figure 2.1.1-1 Verification Model

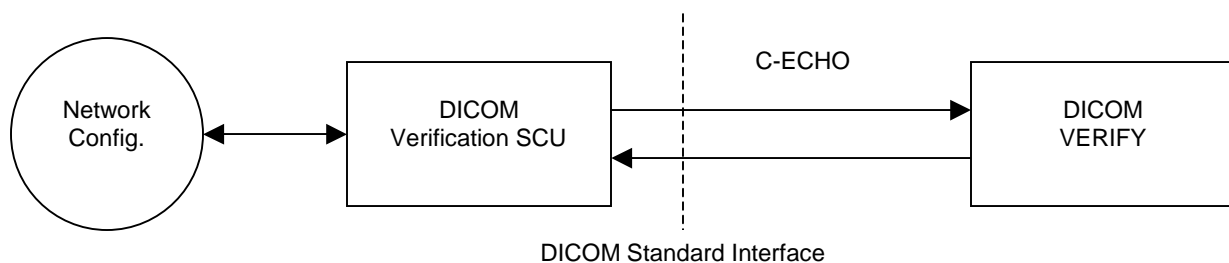

## 2.1.2 Image Export

Image Export allows the user to export Sequoia single frame and multi-frame ultrasound images to a DICOM archive server, which supports the Storage service class as an SCP. In addition, Sequoia also exports a private Structured Report (SR) object to the DICOM archive server if it is a KinetDx Pacs server.

Figure 2.1.2-1 Image Export Model

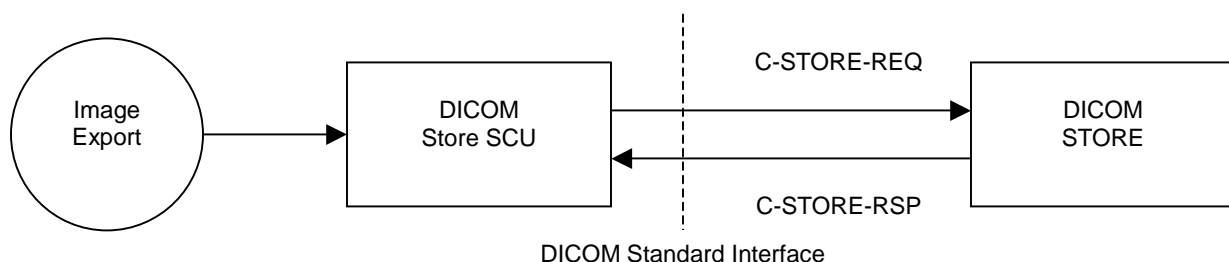

The user can manually use the Study Utils UI to select completed studies and export them on a single association. The destination is selected from a pop-up selection of pre-configured devices.

Additionally, there are automated background image export methods. The system can be set to store either “in-progress” or “on study close” where:

- The system automatically exports an image as soon as it is captured and saved to the local disk while the study is currently open and in-progress.

- The system automatically exports all the images belonging to the current study as it closes.
- The system automatically exports one or more studies in the background, acquired while in a portable non-networked mode, once it is powered up on the network.

The “in-progress” method distributes the network load over time and can provide image review at the review station in near real-time (provided the server supports this capability). The “on study close” method lets the user store studies more accurately in the server. It is a common practice in Ultrasound to delete some images or modify demographic data before the study is closed.

In the event Sequoia is taken off the network as a portable system or when a network failure occurs during a background export, the Store SCU maintains a queue of failed C-STORE requests. These are periodically retried subsequent to the end of the study. The queue is also retried upon power cycling the Sequoia.

To use background export, the user pre-configures the destinations and mode of copy with the “Define Servers” setup under the Aegis menu located in the Sequoia System Setup. In addition, studies can be copied to two destinations archive servers.

#### 2.1.2.1.1. Private Structured Reporting

Sequoia is capable of sending a Private Structured Report (SR) SOP class object that can only be used by Siemens KinetDx PACS systems. The SR SOP Class will only be sent if (a) Sequoia is configured to store to a DICOM server as a KinetDx system and (b) the association negotiation for the SR SOP Class has been successfully negotiated.

The SR objects contain patient information and any measurements or calculations entered into one of the three Sequoia calculations package worksheets for OB, Cardiac, or Vascular studies.

The product implementation of Structured Reporting predated the adoption of DICOM Supplement 23 and substantially differs from that final version. Data contained in the Sequoia SR object cannot be extracted to populate other Structured Reporting implementations in non-Acuson devices. Sequoia uses a Private Structured Reporting SOP Class UID 1.2.840.10008.5.1.4.1.1.88.3.

### 2.1.3 Image Print

Image Print allows the user to print Sequoia single frame Ultrasound images to a network DICOM printer.

Figure 2.1.3-1 Image Print Model

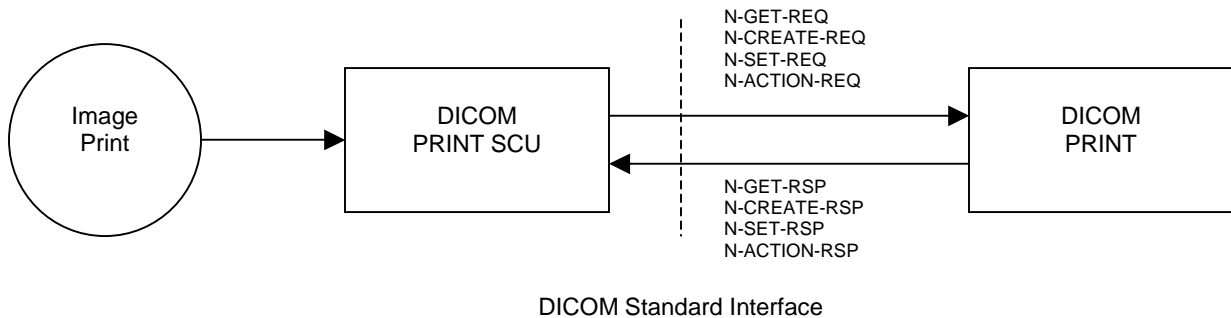

The user can manually use the Study Utils UI to select completed studies for printing. The printers and print formats are determined by the selections made in the “Define Printers” setup under the Aegis menu located in the Sequoia System Setup. It is possible to select one B&W and one color printer to route gray scale images and color doppler images to separate printers.

Additionally, there are automated background printing methods available. The system can be setup to either print a study “in-progress” or “on study close” where:

- The system automatically prints a sheet of film as soon as enough static images have been captured to create a full format while the study is in-progress.
- The system automatically prints all films belonging to the study as soon as the study is closed.
- The system automatically prints in the background, acquired while in a portable non-networked mode, once it is powered up on the network.

Since it can take 30 seconds to several minutes to print all films, the “in-progress” setting will print most of the films before the study is closed. However, for ultrasound users who delete images throughout the study, the “on study close” method will give more correct study printouts.

The user can use the “Print Now” button to force a partially formatted film before it is fully populated with images and automatic printing occurs.

In the event Sequoia is taken off the network as a portable system or a network failure is encountered during a background export, the Print SCU maintains a queue of failed print requests. These are periodically retried subsequent to the end of the study. The queue is also retried upon power cycling the Sequoia.

## 2.1.4 Modality Worklist

The Patient Demographics screen (the Begin Screen) can be automatically filled by using the ‘Worklist’ Real World Activity.

Figure 2.1.4-1 Modality Worklist Model

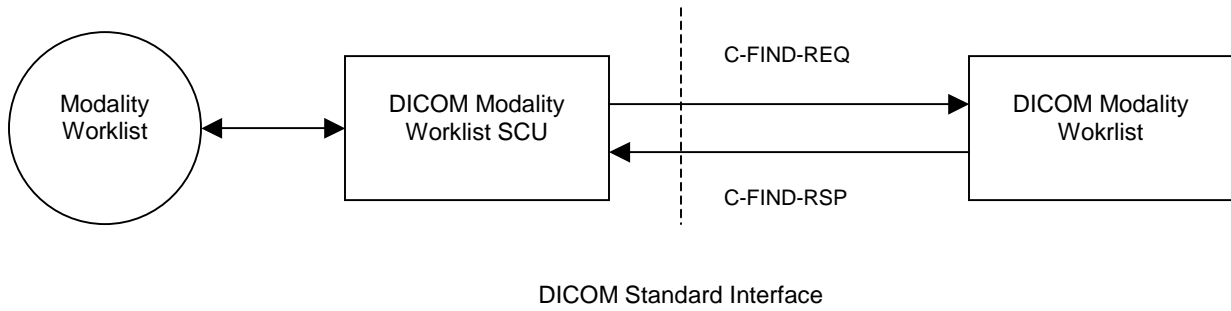

Depressing the 'Begin/End' key on the keyboard initiates the patient demographics screen. Clicking on the 'Query' button initiates the search. The search criteria is limited to the following Request to Return Elements:

- Patient Name
- Patient ID
- Accession Number
- Procedure Start Date
- Modality
- Station AE Title

The Patient Name, Patient ID, and Accession Number fields that are partially filled or empty will be treated as though an implicit wildcard was appended at the end of the field. If only one matching patient is found in the query, the patient demographics screen will be immediately populated using the returned information. If no matches are found, a message will be presented to the operator indicating so. If more than one matching patient is found, a pick list of patient exams will be presented to the user to select from. The list will be limited to the number that was specified in the Dicom Worklist Server Setup.

The user will have the option to select a patient study, or cancel the operation. Selection of a patient from the list will cause all demographic information for that patient to be loaded in the patient demographic screen.

The following data fields will be populated on the patient demographics screen:

Attribute Name	Tag
Patient's Full Name	(0010,0010)
Patient ID	(0010,0020)
Study Type	(0040,0007)*
Accession Number	(0008,0050)
SSN	(0010,1000)
Date of Birth	(0010,0030)
Indication	(0040,1002)
Sex	(0010,0040)

Weight	(0010,1030)
Height	(0010,1020)
Diagnosing Physician	(0008,1060)
Referring Physician	(0008,0090)

\* This tag will later be mapped to the Study Description tag (0008,1030) in the Storage SOP Class.

See Section 3.1.2.4.2 (Modality Worklist Service SOP Class) for more specific details.

### 2.1.5 Modality Performed Procedure Step

The Sequoia DICOM Modality Performed Procedure Step (MPPS) uses the DICOM 3.0 MPPS service class SCU to send event transactions, which are triggered at the start of a study (i.e. once the first image/clip is acquired) and at the end of a study. The MPPS SCU supports both the N-CREATE and N-SET DIMSE Service Elements. A different MPPS server can be configured separately from a Modality Worklist server on the Sequoia system.

This information can be used by the Hospital Information System to manage its list of scheduled patients that is requested by a DICOM Modality Worklist query.

When a study is started on Sequoia, it uses the N- CREATE DIMSE to construct an MPPS-SOP with the MPPS server SCP. There is no further interaction with the MPPS SCP until the study ends. When the study is closed, the Sequoia system uses the N-SET DIMSE to set the values contained in the MPPS-SOP.

The Sequoia N-SET value for the “Performed Procedure Step Status” (0004,0252) is set to “COMPLETED”. Additionally, the contents of the “Performed Series Sequence” (0040,0340) are updated so that all mandatory attributes are supplied to the SCP.

Figure 2.1.5-1 Modality Performed Procedure Step Model

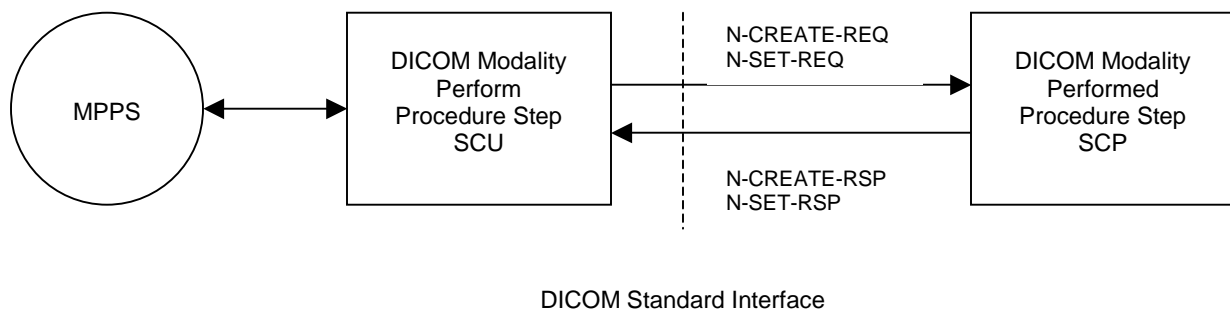

### 2.1.6 Storage Commitment

DICOM Storage Commitment is embedded in the successful completion of a study store to a DICOM Store SCP. It is dynamically negotiated when all images have been successfully stored to a server. In the case of Structured Reporting for KinetDx servers, Sequoia includes an SR SOP instance UID in the Storage

Commitment N-ACTION request and will process the N-EVENT-REPORT for the SR SOP instance.

Sequoia uses the DICOM Storage Commitment Push Model to inform the server when all stores for a study have been completed. The Storage Commitment SCU uses the N-ACTION primitive to make a request to the SCP for safekeeping of a set of SOP instances (eg: Ultrasound images).

The Sequoia Storage Commitment SCU also performs a role reversal and becomes the SCP for the N-EVENT-REPORT primitives received from the original SCP (now an SCU).

Figure 2.1.6-1 Storage Commitment Model

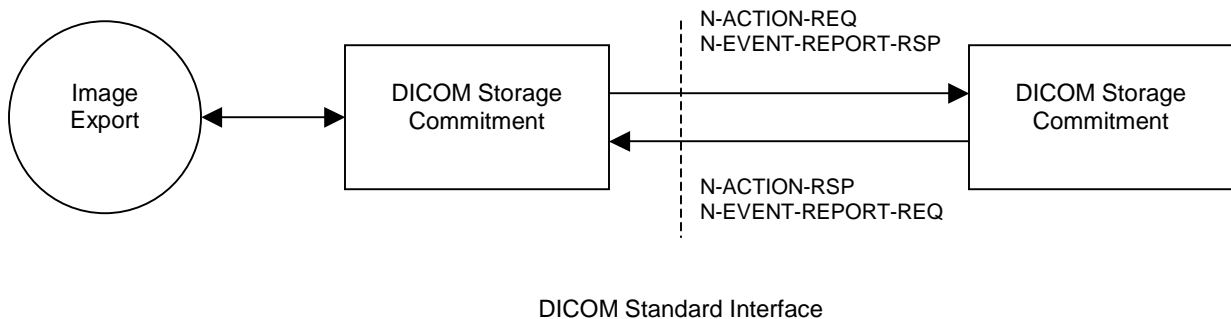

## 2.1.7 DICOM MOD Media Interchange

The DICOM MOD Media Interchange performs the following:

Table 2.1.7-1 DICOM Ultrasound Application Profiles

Application Profile	Real-World Activity	Role
STD-US-SF-MOD128	Create MO	FSC, [FSU*, FSR*]
STD-US-MF-MOD128	Create MO	FSC, [FSU*, FSR*]
STD-US-SF-MOD230	Create MO	FSC, [FSU*, FSR*]
STD-US-MF-MOD230	Create MO	FSC, [FSU*, FSR*]
STD-US-SF-MOD540	Create MO	FSC, [FSU*, FSR*]
STD-US-MF-MOD540	Create MO	FSC, [FSU*, FSR*]
STD-US-SF-MOD640	Create MO	FSC, [FSU*, FSR*]
STD-US-MF-MOD640	Create MO	FSC, [FSU*, FSR*]

\*Updater/Reader only applicable to Sequoia & Aspen systems

- File-set creator (FSC): it creates a DICOM MOD medium when the user copies studies/images to MO. A DICOM 3.0 conforming DICOMDIR file is created together with the directory structures and image files.
- Supported MO disk formats are 128MB, 230MB, 540MB, and 640MB

- The Sequoia physical MO drive may be either a 230MB, 640MB, or 1.3GB drive.
- Sequoia creates a partitioned MOD if formatted on the system.
- File-set updater (FSU<sup>\*</sup>): it modifies the DICOMDIR file and image files when the user copies or deletes studies.
- File-set reader (FSR<sup>\*</sup>): it reads the DICOMDIR and makes a listing. The DICOMDIR file is read and parsed by the system Study Util user interface to generate the study listing.

Figure 2.1.7-2 DICOM MOD Media Interchange Model

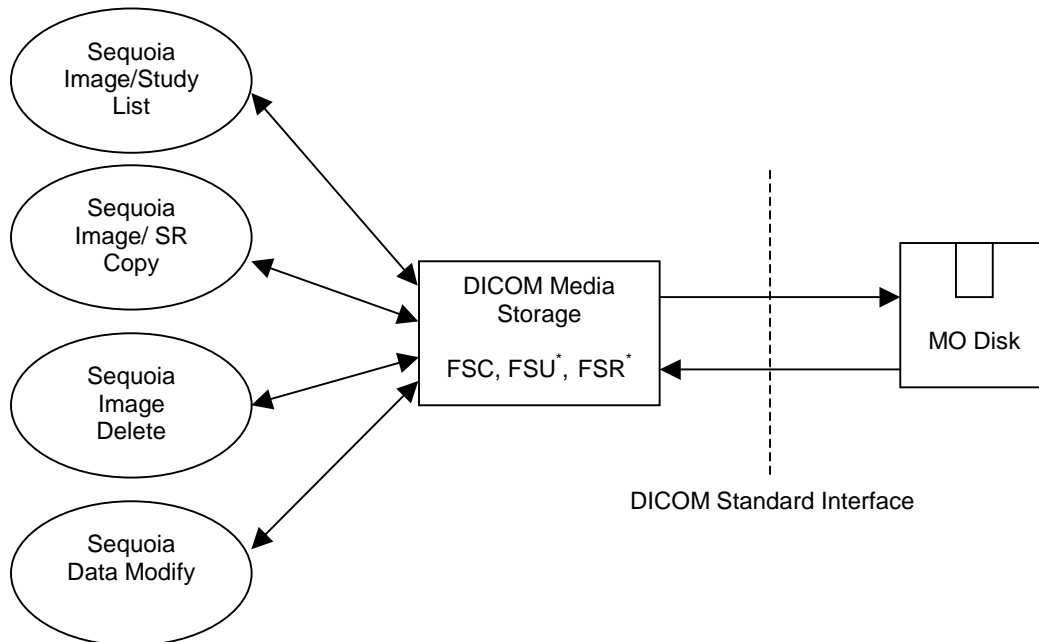

Studies/images can be manually copied to MOD from the Sequoia local hard drive via the Study Util user interface. Note that both SR objects and Private Elements are copied to the MOD.

Studies/images can be manually copied to the Sequoia local hard drive from MOD via the Study Util user interface. In addition, studies can be reviewed directly from the MO disk.

Limitations:

- Only Aspen and Sequoia studies can be copied to and from MOD. An MOD can contain a mix of Aspen and Sequoia studies.
- Only Aspen and Sequoia created studies can be reviewed on Sequoia.
- The Aspen release version must be 3.0 or greater.
- The Sequoia release version must be 1.0 or greater.

The level of compatibility of Sequoia 8.0 DICOM MODs with a non-Acuson DICOM 3.0 reader must be assessed by the maker of the reader.

## **2.2 AE Functional Definition**

### **2.2.1 Verification Real-World Activities**

The Sequoia application entity performs Verification Service Class as SCU and SCP thus allowing the operator to verify the ability of an application on a remote node to receive DICOM messages.

### **2.2.2 Image Export Real-World Activities**

The Sequoia application entity performs all of the functions to transmit ultrasound images and associated data to network servers and/or workstations. The Sequoia AE supports both Ultrasound Image and Ultrasound Multi-frame Image Store SOP classes as an SCU.

### **2.2.3 Image Print Real-World Activities**

The Sequoia AE provides all aspects of the Print Management SCU. The AE initiates separate associations to the print server. The Sequoia AE accommodates both grayscale and color print servers.

### **2.2.4 Modality Worklist Real-World Activities**

The Sequoia AE supports the DICOM Basic Worklist Management Service as an SCU. The AE initiates an association to the active Worklist server when a Worklist query is selected (via the “Query” softkey) or when Sequoia is configured for Pre-fetch. The association is closed upon the completion of each query.

### **2.2.5 Modality Performed Procedure Step Real-World Activities**

The Sequoia AE supports Modality Performed Procedure Step (MPPS) in the role of SCU.

### **2.2.6 Storage Commitment Real-World Activities**

The Sequoia AE supports Storage Commitment Push Model SOP class to inform servers when all the store operations for a study have been completed. The Storage Commitment SCU uses the N-ACTION primitive to request safekeeping of a set of SOP Instances (Ultrasound Images and SR objects). The Storage Commitment SCU also processes the N-EVENT-REPORT primitives that are received from the SCP indicating ‘successful’ or ‘non-successful’ commitment status. Currently the N-EVENT-REPORT information is not used to mark ‘eligible’ images for deletion from the Sequoia hard drive.

### **2.2.7 DICOM MOD Media Interchange Real-World Activities**

The Sequoia AE supports the DICOM MOD Media Interchange. The supported MO disk formats Sequoia currently can write are 128MB, 230MB, 540MB, and 640MB. Note that Sequoia can only read studies that were generated from Aspen or Sequoia systems – it cannot read from other vendors’ disks.

### 3. AE Specifications

The following specifications apply to the AE as depicted in Figure 2.1-1 on page 5.

#### 3.1 Sequoia AE Specification

The Sequoia AE provides conformance to the following DICOM Service SOP Classes as an SCU:

Table 3.1-1 Supported SOP Classes

Service SOP Class Name	SOP Class UID
Verification	1.2.840.10008.1.1
Ultrasound Image Storage	1.2.840.10008.5.1.4.1.1.6.1
Ultrasound Image Storage (Retired)	1.2.840.10008.5.1.4.1.1.6
Ultrasound Multi-frame Image Storage	1.2.840.10008.5.1.4.1.1.3.1
Ultrasound Multi-frame Image Storage (Retired)	1.2.840.10008.5.1.4.1.1.3
Secondary Capture Image Storage	1.2.840.10008.5.1.4.1.1.7
Basic Grayscale Print Management Meta	1.2.840.10008.5.1.1.9
Basic Color Print Management Meta	1.2.840.10008.5.1.1.18
Storage Commitment Push Model	1.2.840.10008.1.20.1
Modality Worklist Information Model - FIND	1.2.840.10008.5.1.4.31
Modality Performed Procedure Step	1.2.840.10008.3.1.2.3.3
Structured Report (Acuson)	1.2.840.10008.5.1.4.1.1.88.3*

\*Note – This SOP Class Name is a private Structure Reporting (SR) SOP Class used only by the Acuson ultrasound platforms. This SR SOP Class was implemented before the official DICOM standard's Structure Reporting was finalized. At the time of implementation, the DICOM Standard root ID was incorrectly used instead of the Acuson root ID. Currently the DICOM standard does not use this specific SOP Class UID. The Acuson ultrasound platform has not yet changed the SR SOP Class ID due to backwards compatibility issues for existing customer studies.

#### 3.1.1 Association Establishment Policies

##### 3.1.1.1 General

The Acuson Sequoia system uses TCP/IP. The Maximum Length PDU negotiation is included in all association establishment requests. The maximum length PDU offered for an association initiated by Sequoia is 32768 bytes. However if the receiver negotiates a lower value then the Sequoia will use the lower value. Note that the receiver must negotiate at least a minimum of 128 bytes.

##### 3.1.1.2 Number of Associations

The system uses one association for all types of transactions. The system does not handle multiple associations. All Associations are serial and do not overlap.

### 3.1.1.3 Asynchronous Nature

All associations use the default synchronous mode of operation. Asynchronous Operations Window negotiations are not supported on the Sequoia.

### 3.1.1.4 Implementation Identifying Information

Implementation Class UID: "1.2.840.113680.3.3.0" (See below)

Implementation Version Name: "SEQUOIA\_8.0"

Siemens has provided registration for all Siemens Medical Systems Groups. The unique Class UID for the Acuson product is defined as: "1.2.840.113680"

Where the interpretation is:

- 1. = International Standards Organization (ISO)
- 2. = ANSI member body
- 840. = Country Code (United States)
- 113680 = ANSI Registered number assigned to Acuson products
- 3.3.0 = Merge toolkit version

### 3.1.1.5 Calling and Called AE Titles

The SCU Calling AE Title is pre-configured at the installation time to be:

- SEQUOIA\_serial#

This is modifiable in the Sequoia configuration if necessary.

The "Called AE Title" is used by a SCP. This Sequoia release does not contain a SCP, except in its role reversal in the Storage Commitment SOP Class.

## 3.1.2 Association Initiation by Real-World Activities

### 3.1.2.1 Real World Activity – Verification

The Sequoia is capable of supporting Verification service class as an SCU and SCP. Verification can be initiated in the Network Configuration window under the SUI menu.

#### 3.1.2.1.1. Proposed Presentation Contexts – Verification

The Sequoia will propose Presentation context as shown in the following table:

Table 3.1.2.1.1-1 Verification Presentation Context Table

Presentation Context Table					
Abstract Syntax		Transfer Syntax		Role	Extended Negotiation
Name	UID	Name List	UID List		
Verification	1.2.840.10008.1.1	Implicit VR Little Endian	1.2.840.10008.1.2	SCU SCP	None

### 3.1.2.2 Real World Activity – Store

When images are transferred to a DICOM Store SCP, the system establishes an association between the Sequoia AE and the identified DICOM device (i.e. Network Archive Server, Workstation Server).

The Sequoia system can be configured to send studies in one of the following ways:

1. In-Progress
2. On Study Close
3. Study Utils (Bulk Store)

When studies are sent using “In-Progress”, individual images are sent to the store device as they are acquired. In the “On Study Close” all images are sent at the end of the study. Finally the Study Utils Bulk Store is used to store one or more studies from a list of studies.

#### 3.1.2.2.1. Proposed Presentation Context

The following Presentation Context(s) is presented to the SCP in an A-Associate request for DIMSE C-STORE storage services. The storage services utilize C-STORE services, whose parameters are defined in PS 3.7 (Table 9.1-1). The following Presentation Context applies to all three Sequoia store modes:

Table 3.1.2.2.1-1 Store Presentation Context Table

Presentation Context Table					
Abstract Syntax		Transfer Syntax		Role	Extended Negotiation
Name	UID	Name List	UID List		
Ultrasound Image Storage	1.2.840.10008.5.1.4.1.1.6.1	RLE Lossless	1.2.840.10008.1.2.5	SCU	None
Ultrasound Image Storage	1.2.840.10008.5.1.4.1.1.6.1	Implicit VR Little Endian	1.2.840.10008.1.2	SCU	None
Ultrasound Multi-frame Image Storage	1.2.840.10008.5.1.4.1.1.3.1	JPEG Baseline	1.2.840.10008.1.2.4.50	SCU	None
Ultrasound Multi-frame Image Storage	1.2.840.10008.5.1.4.1.1.3.1	Implicit VR Little Endian	1.2.840.10008.1.2	SCU	None
Ultrasound Image Storage (Retired)	1.2.840.10008.5.1.4.1.1.6	Implicit VR Little Endian	1.2.840.10008.1.2	SCU	None
Ultrasound Multi-frame Image Storage (Retired)	1.2.840.10008.5.1.4.1.1.3	Implicit VR Little Endian	1.2.840.10008.1.2	SCU	None
Secondary Capture Image Storage	1.2.840.10008.5.1.4.1.1.7	Implicit VR Little Endian	1.2.840.10008.1.2	SCU	None
Structured Report (Acuson)	1.2.840.10008.5.1.4.1.1.88.3	Implicit VR Little Endian	1.2.840.10008.1.2	SCU	None

The Sequoia system always acts as an SCU and is the client in a client-server model. The system will negotiate associations in the following order: New US IOD, Retired US IOD, and Secondary Capture.

Sequoia sends SOP class UID and transfer syntax UID pairs to negotiate for supported presentation contexts in the following method:

- SOP class UID 1 and Transfer Syntax UID 1
- SOP class UID 1 and Transfer Syntax UID 2
- SOP class UID 2 and Transfer Syntax UID 1

...

This may pose problems to servers that can only recognize the following method of grouping:

- SOP class UID 1 and Transfer Syntax UID 1, Transfer Syntax UID 2
- SOP class UID 2 and Transfer Syntax UID 1, ...

### 3.1.2.2.2. Photometric Interpretation

Photometric Interpretation (color mode of the pixel image data) is not a negotiable parameter in DICOM 3.0. This implementation exports color images in RGB mode and grayscale images in Monochrome2 if the peer AE accepts only uncompressed Implicit VR Little Endian transfer syntax. It is also possible to manually configure the ultrasound system to export color images as Monochrome 2. This is done by enabling the Grey Store service in the Network Configuration menu (SUI).

If the peer AE accepts either RLE or JPEG compression transfer syntax, images are exported in a YBR color mode (see Table 3.1.2.2.2-1).

Table 3.1.2.2.2-1 Photometric Interpretation of Exported Images

Ultrasound Image SOP Class UID	Transfer Syntax and UID	Image Content	Photometric Interpretation
Single-frame: 1.2.840.10008.5.1.4.1.1.6.1 1.2.840.10008.5.1.4.1.1.6 1.2.840.10008.5.1.4.1.1.7	Implicit VR Little Endian 1.2.840.10008.1.2	B/W	MONOCHROME2
Multi-frame: 1.2.840.10008.5.1.4.1.1.3.1 1.2.840.10008.5.1.4.1.1.3		Color	RGB
Single-frame: 1.2.840.10008.5.1.4.1.1.6.1	RLE Lossless Compression 1.2.840.10008.1.2.5	B/W or Color	YBR_FULL
Multi-frame: 1.2.840.10008.5.1.4.1.1.3.1	JPEG Baseline Compression 1.2.840.10008.1.2.4.50	B/W or Color	YBR_FULL_422

### 3.1.2.2.3. Storage SOP Classes: DICOM IOD Specification

This implementation uses DICOM 3.0 Part 3 as the DICOM Image IOD specification. All Type 1 and 2 elements specified in the DICOM 3.0 standard are encoded and exported. Some Type 3, 1C and 2C elements are also exported.

The following table denotes the attributes included in the Ultrasound Image Object as implemented on the Sequoia. Attributes not listed are not used.

Table 3.1.2.2.3-1 US Image IOD Attributes used

Module	Attribute	Tag	Notes
Patient	Patient Name	(0010,0010)	From MWL or user input at Sequoia Begin Screen – First, Last, Prefix, & Suffix fields. Default is NULL.
	Patient ID	(0010,0020)	From MWL or user input at Sequoia Begin Screen – Patient ID field. Default is Snnnnn.xxxxxxxx where nnnnn is system serial number and xxxxxxxx is a Unix time stamp.
	Patient's Birth Date	(0010,0030)	From MWL or user input at Sequoia Begin Screen – DOB field. Default is NULL.
	Patient Sex	(0010,0040)	From MWL or user input at Sequoia Begin Screen – Sex field. M = Male, F = Female. Default is "O".
	Other Patient Ids	(0010,1000)	From MWL or user input at Sequoia Begin Screen – SSN field. Default is NULL.
	Patient Comments	(0010,4000)	From MWL or user input at Sequoia Begin Screen – Comment field. Default is NULL.
General Study	Study Instance UID	(0020,000D)	From MWL or created by Sequoia
	Study Date	(0008,0020)	The date when the Sequoia was entered into the Begin Screen.
	Study Time	(0008,0030)	The time when the Sequoia was entered into the Begin Screen
	Referring Physician's Name	(0008,0090)	From MWL or user input at Sequoia Begin Screen – Referring Physician field. Default is NULL.
	Study ID	(0020,0010)	Sequoia Begin Screen – Value is set to the Study Type selected.
	Accession Number	(0008,0050)	From MWL or user input at Sequoia Begin Screen – Accession Field. Default is NULL.
	Study Description	(0008,1030)	From MWL or user input at Sequoia Begin Screen – Value is set to the Study Type selected for the study.
	Name of Physician(s) Reading Study	(0008,1060)	From MWL or user input at Sequoia Begin Screen – Diagnosing Physician field. Default is NULL.
	Patient's Size	(0010,1020)	From MWL or user input at Sequoia Begin Screen – Height field. Default is NULL.

	Patient's Weight	(0010,1030)	From MWL or user input at Sequoia Begin Screen – Weight field. Default is NULL.
General Series	Modality	(0008,0060)	Set to "US"
	Series Instance UID	(0020,000E)	Created by Sequoia
	Series Number	(0020,0011)	Set to "1"
	Operator Name	(0008,1070)	Sequoia Begin Screen – Sonographer field. Default is NULL.
General Equipment	Manufacturer	(0008,0070)	Set to "ACUSON"
	Institution Name	(0008,0080)	From MWL or user input at Sequoia Setup (Screen Options) – Institution field. Default is NULL.
	Station Name	(0008,1010)	Sequoia Begin Screen – Machine ID. Default is NULL.
	Institutional Department Name	(0008,1040)	Sequoia Begin Screen – Department field. Default is NULL.
	Manufacturer's Model Name	(0008,1090)	Set to "SEQUOIA"
	Device Serial Number	(0018,1000)	Set to Sequoia's serial number.
	Software Versions	(0018,1020)	Set to "8.0"
General Image	Image Number	(0020,0013)	Image number in study (1 – n).
	Patient Orientation	(0020,0020)	Set to NULL.
	Image Date	(0008,0023)	Date the image was captured.
	Image Time	(0008,0033)	Time the image was captured.
	Images in Acquisition	(0020,1002)	Number of images that resulted from the study (1-n).
	Lossy Image Compression	(0028,2110)	Set to "00" for single-frame images, "01" for multi-frame images.
Image Pixel	Samples per Pixel	(0028,0002)	1 = MONOCHROME2, 3 = RGB or YBR_FULL
	Photometric Interpretation	(0028,0004)	Set to the following:  RGB = Uncompressed color images (single- or multi-frame),  MONOCHROME2 = Uncompressed b/w images (single- or multi-frame),  YBR_FULL = Compressed single-frame images (color or b/w),  YBR_FULL_422 = Compressed multi-frame images (color or b/w)
	Rows	(0028,0010)	Set to 480 for full size images and 240 for ¼ size images. (NTSC)  Set to 576 for full size images and 288 for ¼ size images. (PAL)
	Columns	(0028,0011)	Set to 640 for full size images and 320 for ¼ size images. (NTSC)  Set to 768 for full size images and 384 for ¼ size images. (PAL)
	Bits Allocated	(0028,0100)	Set to 8
	Bits Stored	(0028,0101)	Set to 8

	High Bit	(0028,0102)	Set to 7
	Pixel Representation	(0028,0103)	Set to 0000H = Unsigned integer
	Pixel Data	(7FE0,0010)	
	Planar Configuration	(0028,0006)	Indicates whether the pixel data are sent color-by-plane or color-by-pixel. Required if Samples per Pixel (0028,0002) has a value greater than 1. Enumerated values are: 0000H = Color-by-pixel 0001H = Color-by-plane  Sequoia sets to: 0000H for multi-frame images, 0001H for single-frame images.
Multi-frame	Number of frames	(0028,0008)	
	Frame Increment Pointer	(0028,0009)	Set to (0018,1065)
US Region Calibration	Sequence of Ultrasound Regions	(0018,6011)	
	>Region Location Min $x_0$	(0018,6018)	
	>Region Location Min $y_0$	(0018,601A)	
	>Region Location Max $x_1$	(0018,601C)	
	>Region Location Max $y_1$	(0018,601E)	
	>Physical Units X Direction	(0018,6024)	Physical units of the dimensions of the region. Applicable values are: 0000H = None 0003H = cm 0004H = seconds 0007H = cm/seconds
	>Physical Units Y Direction	(0018,6026)	Physical units of the dimensions of the region. Applicable values are: 0000H = None 0003H = cm 0004H = seconds 0007H = cm/seconds
	>Physical Delta X	(0018,602C)	
	>Physical Delta Y	(0018,602E)	
	>Reference Pixel $x_0$	(0018,6020)	
	>Reference Pixel $y_0$	(0018,6022)	
	>Ref. Pixel Physical Value X	(0018,6028)	
	>Ref. Pixel Physical Value Y	(0018,602A)	
	>Region Spatial Format	(0018,6012)	The spatial organization of the data within the region. Possible values: 0000H = None 0001H = 2-D (tissue or flow) 0002H = M-Mode (tissue or flow) 0003H = Spectral (CW or PW Doppler) 0004H = Wave form (physiological traces, Doppler traces,...) 0005H = Graphics

	>Region Data Type	(0018,6014)	The type of data within the region. Possible values: 0000H = None 0001H = Tissue 0002H = Color Flow 0003H = PW Spectral Doppler 0004H = CW Spectra Doppler 0005H = Doppler Mean Trace 0006H = Doppler Mode Trace 0007H = Doppler Max Trace 0008H = Volume Trace 0009H = d(volume)/dt Trace 000AH = ECG Trace 000BH = Pulse Trace 000CH = Phonocardiogram Trace 000DH = Gray bar 000EH = Color bar 000FH = Integrated Backscatter 0010H = Area Trace 0011H = d(area)/dt 0012H = Other Physiological (Amplitude vs. Time) input
	>Region Flags	(0018,6016)	Flags used for special handling of the region. Bit 0 – Transparency: 1 = Transparent 0 = Opaque Bit 1 – Scaling Protection: 1 = Protected 0 = Not Protected Bit 2 – Doppler Scale Type 1 = Frequency 0 = Velocity
	>Doppler Correction Angle	(0018,6034)	
	>Doppler Sample Volume X Position	(0018,6038)	
	>Doppler Sample Volume Y Position	(0018,603A)	
	>TM-Line Position $x_0$	(0018,603C)	
	>TM-Line Position $Y_0$	(0018,603E)	
	>TM-Line Position $x_1$	(0018,6040)	
	>TM-Line Position $Y_1$	(0018,6042)	

US Image	Image Type	(0008,0008)	<p>This tag has four values associated with it. The first two values are set as follows:</p> <p>The First value is "ORIGINAL\PRIMARY" if the image is not a recaptured image.</p> <p>The Second value is "DERIVED\PRIMARY" if the image is a ¼ size rendition of the original full size image.</p> <p>"DERIVED\SECONDARY" if the image is a recaptured image.</p> <p>The Third value is set to NULL.</p> <p>The Fourth value is constructed as a bit map to allow for a description of multi-mode displays. In using this bit map, the sum of the values of the various modalities will unambiguously determine the constituent mode displays:</p> <p>0001 = 2-D  0002 = M-MODE  0004 = CW DOPPLER  0008 = PW DOPPLER  0010 = COLOR DOPPLER  0020 = COLOR M-MODE  0040 = 3-D</p>
	Stage Name	(0008,2120)	<p>A Stage is a particular time interval of a protocol during which a set of images are collected. The names can be free form text.</p> <p>Recommended text for Stress Echo stage names are:</p> <p>PRE_EXERCISE  POST-EXERCISE  PEAK-EXERCISE  RECOVERY  BASELINE  LOW DOSE  PEAK DOSE</p>
	Stage Number	(0008,2122)	A number that identifies the Stage. Stage numbers start at one.
	Number of Stages	(0008,2124)	Number of Stages in this protocol. Required if image was acquired in a Stage protocol
	View Number	(0008,2128)	A number that identifies the View. View numbers start at one.

	Number of Event Timers	(0008,2129)	Number of Event Timers used at the time of acquisition of a multi-frame image
	Number of Views in Stage	(0008,212A)	Number of views in this stage. Required if image was acquired in a Staged Protocol
	Event Elapsed Time(s)	(0008,2130)	An array of values associated with each Event Timers. Units in milliseconds.
	Event Timer Name(s)	(0008,2132)	Name(s) that identifies the Event Timer(s).
	Start Trim	(0008,2142)	The frame number of the first frame of the multi-frame image to be displayed.
	Stop Trim	(0008,2143)	The frame number of the last frame of a multi-frame image to be displayed.
	Trigger Time	(0018,1060)	Time interval measured in msec from the start of the R-wave to the beginning of data taking.
	Frame Time Vector	(0018,1065)	An array which contains the real time increments (in msec) between frames for a multi-frame image.
	Heart Rate	(0018,1088)	Beats per minute
	Transducer Data	(0018,5010)	Set to model number of Transducer
	Transducer Type	(0018,6031)	Defined Terms: SECTOR_PHASED SECTOR_MECH SECTOR_ANNULAR LINEAR CURVED LINEAR SINGLE CRYSTAL SPLIT XTAL CWD IV_PHASED IV_ROT XTAL IV_ROT MIRROR ENDOCAV_PA ENDOCAV_MECH ENDOCAV_CLA ENDOCAV_AA ENDOCAV_LINEAR VECTOR_PHASED

SOP Common	SOP Class UID	(0008,0016)	Possible values are: 1.2.840.10008.5.1.4.1.1.6.1 Ultrasound Image Storage 1.2.840.10008.5.1.4.1.1.6 Ultrasound Image Storage (Retired) 1.2.840.10008.5.1.4.1.1.3.1 Ultrasound Multi-frame Image Storage 1.2.840.10008.5.1.4.1.1.3 Ultrasound Multi-frame Image Storage (Retired) 1.2.840.10008.5.1.4.1.1.7 Secondary Capture 1.2.840.10008.5.1.4.1.1.88.3 Structured Report (Acuson)
	SOP Instance UID	(0008,0018)	Created by Sequoia
	Specific Character Set	(0008,0005)	Set to "ISO_IR 100"
Requested Procedure	Requested Procedure ID	(0040,1001)	From MWL or Sequoia sets value to NULL
Scheduled Procedure Step	Scheduled Procedure Step Description	(0040,0007)	Value set to NULL
	Scheduled Procedure Step ID	(0040,0009)	Value set to NULL
Performed Procedure Step Information	Performed Procedure Step Start Date	(0040,0244)	The date when the study was closed.
	Performed Procedure Step Start Time	(0040,0245)	The time when the study was closed.
	Performed Procedure Step ID	(0040,0253)	The value will be the same as the Study Description tag (0008,1030).
	Performed Procedure Step Description	(0040,0254)	The value will be the same as the Study Description tag (0008,1030).

Sequoia sends Acuson private elements only when sending to a KinetDx or Perspective system. These Acuson private elements include elements from the 0x7FDF group tags. The data for these Acuson private elements are parsed out from the Sequoia study's proprietary ACQ\_SET, CLIPS/IMAGES, and DBRECORD files (see section 6.1).

### 3.1.2.3 Real World Activity – Print

When print is initiated either by background (On Study Close/In Progress) or foreground (Study Utils) printing, an association with the assigned DICOM Printer/Print Server is made.

### 3.1.2.3.1. Proposed Presentation Context to a Grayscale Printer

Table 3.1.2.3.1-1 Grayscale Print Presentation Context Table

Presentation Context Table					
Abstract Syntax		Transfer Syntax		Role	Extended Negotiation
Name	UID	Name List	UID List		
Basic Grayscale Print Management Meta SOP Class	1.2.840.10008.5.1.1.9	DICOM Implicit VR Little Endian	1.2.840.10008.1.2	SCU	None

Table 3.1.2.3.1-2 Basic Grayscale Print Management Meta SOP Classes

SOP Class Name	SOP Class UID
Printer SOP Class	1.2.8.40.10008.5.1.1.16
Basic Film Session SOP Class	1.2.8.40.10008.5.1.1.1
Basic Film Box SOP Class	1.2.8.40.10008.5.1.1.2
Basic Grayscale Image Box SOP Class	1.2.8.40.10008.5.1.1.4

### 3.1.2.3.2. Printer SOP Class

Table 3.1.2.3.2-1 Printer SOP Class

Attribute Name	Attribute Tag	Range	Description
Printer Status	(2110,0010)	NORMAL, WARNING, FAILURE	Printer device status <b>Note:</b> Sequoia will generate a print error if this tag is not sent with a value of NORMAL
Printer Status Info	(2110,0020)		Additional information about Printer Status (2110,0010)
Printer Name	(2110,0030)		User defined name identifying the printer
Manufacturer	(0008,0070)		Manufacture of the printer
Manufacturer Model Name	(0008,1090)		Manufacture's model number of the printer
Device Serial Number	(0018,1000)		Manufacture's serial number of the printer
Software Versions	(0018,1020)		Manufacture's designation of software version of the printer
Date Last Calibration	(0018,1020)		Date when the printer was last calibrated
Last Calibration	(0018,1200)		Time when the printer was last calibrated

Sequoia uses the following DIMSE Services for the Printer SOP Class:  
**N-GET** – Request printer status and information

### 3.1.2.3.3. Basic Film Session SOP Class

Table 3.1.2.3.3-1 Basic Film Session SOP Class

Attribute Name	Attribute Tag	Range	Description
Number of Copies	(2000,0010)	1 to 99	Number of requested film copies
Print Priority	(2000,0020)	HIGH, MED, LOW	Set at configuration
Medium Type	(2000,0030)	PAPER BLUE FILM CLEAR FILM	Media used for hardcopy; may be further limited by printer/print server
Film Destination	(2000,0040)	PROCESSOR	May be further limited by printer/print server
Film Session Label	(2000,0050)	SEQUOIA IMAGE	

Sequoia uses the following DIMSE Services for the Basic Film Session SOP Class:  
**N-CREATE** - Creates the Film Session

### 3.1.2.3.4. Basic Film Box SOP Class

Table 3.1.2.3.4-1 Basic Film Box SOP Class

Attribute Name	Attribute Tag	Range	Description
Image Display Format	(2010,0010)	STANDARD\1,1 STANDARD\1,2 STANDARD\2,1 STANDARD\2,2 STANDARD\2,3 STANDARD\3,2 STANDARD\3,3 STANDARD\3,4 STANDARD\3,5 STANDARD\4,3 STANDARD\4,4 STANDARD\4,5 STANDARD\4,6 STANDARD\5,3 STANDARD\5,4 STANDARD\5,6 STANDARD\6,4 STANDARD\6,5	May be further limited by printer/print server
Film Orientation	(2010,0040)	PORTRAIT LANDSCAPE	May be further limited by printer/print server
Film Size ID	(2010,0050)	8INX10IN 11INX14IN 14INX14IN 14INX17IN	May be further limited by printer/print server
Magnification Type	(2010,0060)	REPLICATE BILINEAR CUBIC NONE	Printer specific

Minimum Density	(2010,0120)	0 or higher	Printer specific
Maximum Density	(2010,0130)	350 or lower	Printer specific
Border Density	(2010,0100)	BLACK WHITE	
Empty Image Density	(2010,0110)	BLACK WHITE	
Trim	(2010,0140)	YES NO	

Sequoia uses the following DIMSE Services for the Basic Film Box SOP Class:

**N-CREATE** - Creates the Film Box

**N-DELETE** - Deletes the Film Box. Issued after each film is printed

**N-ACTION** - PRINT. Sent after each Film Box is filled or to force a print of partially filled Film Box

### 3.1.2.3.5. Basic Film Grayscale Image Box SOP Class

Table 3.1.2.3.5-1 Basic Film Grayscale Image Box SOP Class

Attribute Name	Attribute Tag	Range	Description
Image Position	(2020,0010)		
Polarity	(2020,0020)		
Basic Grayscale Image Sequence	(0028,0002)		
>Samples Per Pixel	(0028,0002)	Set to 1	
>Photometric Interpretation	(0028,0004)	Set to MONOCHROME2	
>Rows	(0028,0010)	Set to 480 NTSC / 576 PAL	
>Columns	(0028,0011)	Set to 640 NTSC / 768 PAL	
>Pixel Aspect Ratio	(0028,0034)	Set to 1 \ 1	
>Bits Allocated	(0028,0100)	Set to 8	
>Bits Stored	(0028,0101)	Set to 8	
>High Bit	(0028,0102)	Set to 7	
>Pixel Representation	(0028,0103)	Set to 0000H = Unsigned integer	
>Pixel Data	(7FE0,0010)		

Sequoia uses the following DIMSE Services for the Basic Grayscale Image Box SOP Class:

**N-SET** - Creates the individual images on the film.

### 3.1.2.3.6. Proposed Presentation Context to a Color Printer

Table 3.1.2.3.6-1 Color Print Presentation Context Table

Presentation Context Table					
Abstract Syntax		Transfer Syntax		Role	Extended Negotiation
Name	UID	Name List	UID List		
Basic Color Print Management Meta SOP Class	1.2.840.10008.5.1.1.18	DICOM Implicit VR Little Endian	1.2.840.10008.1.2	SCU	None

Table 3.1.2.3.6-2 Basic Color Print Management Meta SOP Classes

SOP Class Name	SOP Class UID
Printer SOP Class	1.2.8.40.10008.5.1.1.16
Basic Film Session SOP Class	1.2.8.40.10008.5.1.1.1
Basic Film Box SOP Class	1.2.8.40.10008.5.1.1.2
Basic Color Image Box SOP Class	1.2.8.40.10008.5.1.1.4.1

### 3.1.2.3.7. Basic Film Color Image Box SOP Class

The Basic Color Image Box SOP Class makes identical use of the Printer SOP Class, Basic Film Session SOP Class and Basic Film Box SOP Class elements, which have been previously described for grayscale image printing. Therefore these will not be described again in this section on color printing. However, it should be noted that certain attributes, such as Medium Type, which is defined in the Basic Film Session SOP Class, are highly likely to require print/print server specific media.

Table 3.1.2.3.7-1 Basic Film Color Image Box SOP Class

Attribute Name	Attribute Tag	Range	Description
Image Position	(2020,0010)		
Polarity	(2020,0020)		
Basic Color Image Sequence	(2020,0111)		
>Samples Per Pixel	(0028,0002)	Set to 3	
>Photometric Interpretation	(0028,0004)	Set to RGB	
>Planar Configuration	(0028,0006)	Set to 0	
>Rows	(0028,0010)	Set to 480 NTSC / 576 PAL	
>Columns	(0028,0011)	Set to 640 NTSC / 768 PAL	
>Pixel Aspect Ratio	(0028,0034)	Set to 1 \ 1	
>Bits Allocated	(0028,0100)	Set to 8	
>Bits Stored	(0028,0101)	Set to 8	
>High Bit	(0028,0102)	Set to 7	

>Pixel Representation	(0028,0103)	Set to 0000H = Unsigned integer	
>Pixel Data	(7FE0,0010)		

Sequoia uses the following DIMSE Services for the Basic Color Image Box SOP Class:

**N-SET** - Creates the individual images on the film.

### 3.1.2.4 Real World Activity – Worklist

A separate network association is established by the AE for each worklist query operation, with only one active query at a time. The association is closed at completion of the query.

#### 3.1.2.4.1. Proposed Presentation Context

Table 3.1.2.4.1-1 Worklist Presentation Context Table

Presentation Context Table					
Abstract Syntax		Transfer Syntax		Role	Extended Negotiation
Name	UID	Name List	UID List		
Modality Worklist Information Model – FIND	1.2.840.10008.5.1.4.31	DICOM Implicit VR Little Endian	1.2.840.10008.1.2	SCU	None

The Sequoia system will always act as an SCU and be the client in a client-server model.

#### 3.1.2.4.2. Modality Worklist Service SOP Class

The following table provides the list of attributes requested in the Modality Worklist Query:

Table 3.1.2.4.2-1 Modality Worklist Matching Key Attributes

Attribute Name	Tag	Match Type	Notes
<b>Scheduled Procedure Step</b>			
Scheduled Procedure Step Sequence	(0040,0100)	R	
>Scheduled Station AE title	(0040,0001)	R	The user may set the value of this attribute under the “Filter Worklist” setting located in the Worklist Server setup menu. Possible values are: YES = AE Title of Sequoia NO = NULL value

>Scheduled Procedure Step Start Date	(0040,0002)	R	From the Begin page screen, Sequoia always sets this attribute to today's date. In the Worklist query screen, the user is allowed to select from the following ranges: Today   3Days   1Week   All  Format of range: "yyyymmdd-yyyymmdd"
>Scheduled Procedure Step Start Time	(0040,0003)	R	Set to NULL value
>Modality	(0008,0060)	R	The user may set the value of this attribute under the "Send U/S Study Only" setting located in the Worklist Server setup menu. Possible values are: YES = "US" NO = Any (NULL value)
Accession Number	(0008,0050)	R	Maps to the Accession field in the Sequoia Begin Screen
<b>Patient Identification</b>			
Patient's Name	(0010,0010)	R	Maps to the Patient Name field in the Sequoia Begin Screen
Patient's ID	(0010,0020)	R	Maps to the Patient ID field in the Sequoia Begin Screen

Table 3.1.2.4.2-2 Modality Worklist Return Key Attributes

Attribute Name	Tag	Return Key Type	Notes
<b>SOP Common</b>			
Specific Character Set	(0008,0005)	1C	Sequoia ignores this attribute.
<b>Scheduled Procedure Step</b>			
Scheduled Procedure Step Sequence	(0040,0100)	1	
>Scheduled Station AE title	(0040,0001)	1	The user may set the value of this attribute under the "Filter Worklist" setting located in the Worklist Server setup menu. Possible values are: YES = AE Title of Sequoia NO = NULL value
>Scheduled Procedure Step Start Date	(0040,0002)	1	From the Begin page screen, Sequoia always sets this attribute to today's date. In the Worklist query screen, the user is allowed to select from the following ranges: Today   3Days   1Week   All
>Scheduled Procedure Step Start Time	(0040,0003)	1	Set to NULL value
>Modality	(0008,0060)	1	The user may set the value of this attribute under the "Send U/S Study Only" setting located in the Worklist Server setup menu. Possible values are: YES = "US" NO = Any (NULL value)
>Scheduled Performing Physician's Name	(0040,0006)	2	

>Scheduled Procedure Step Description	(0040,0007)	1C	This attribute is mapped to Sequoia's "Study Type" field on the Begin page. Sequoia ships with a list of study types. The Study Type names can be customized so that RIS and the ultrasound system have the same list to match correctly.
>Scheduled Procedure Step ID	(0040,0009)	3	
>Comments on the Scheduled Procedure Step	(0040,0400)	3	
<b>Requested Procedure</b>			
Study Instance UID	(0020,000d)	1	
Requested Procedure ID	(0040,1001)	1	
Reason for Requested Procedure	(0040,1002)	3	Maps to the Indication field in the Sequoia Begin Screen
Requested Procedure Description	(0032,1060)	3	
<b>Image Service Request</b>			
Accession Number	(0008,0050)	2	Maps to the Accession field in the Sequoia Begin Screen
Referring Physician's Name	(0008,0090)	2	Maps to the Ref. Physician field in the Sequoia Begin Screen
<b>Visit Identification</b>			
Institution Name	(0008,0080)	3	Maps to the Institution field in Sequoia Setup (Screen Options)
<b>Patient Identification</b>			
Patient's Name	(0010,0010)	1	Maps to the Patient Name field in the Sequoia Begin Screen
Patient's ID	(0010,0020)	1	Maps to the Patient ID field in the Sequoia Begin Screen
Patient Other ID	(0010,1000)	3	Maps to the SSN field in the Sequoia Begin Screen
<b>Patient Demographic</b>			
Patient's Birth Date	(0010,0030)	2	Maps to the DOB field in the Sequoia Begin Screen
Patient Sex	(0010,0040)	3	Maps to the Sex field in the Sequoia Begin Screen
Patient Size	(0010,1020)	3	Maps to the Height field in the Sequoia Begin Screen
Patient Weight	(0010,1030)	2	Maps to the Weight field in the Sequoia Begin Screen
Patient Comments	(0010,4000)	3	Maps to the Comments field in the Sequoia Begin Screen
Last Menstrual Date	(0010,21D0)	3	
<b>Study Read</b>			
Name of Physician(s) Reading Study	(0008,1060)	3	Maps to the Diag. Physician field in the Sequoia Begin Screen.

### 3.1.2.5 Real World Activity – Modality Performed Procedure Step

#### 3.1.2.5.1. Proposed Presentation Context

Table 3.1.2.5.1-1 MPPS Presentation Context Table

Presentation Context Table					
Abstract Syntax		Transfer Syntax		Role	Extended Negotiation
Name	UID	Name List	UID List		
Modality Performed Procedure Step	1.2.840.10008.3.1.2.3.3	DICOM Implicit VR Little Endian	1.2.840.10008.1.2	SCU	None

#### 3.1.2.5.2. Modality Performed Procedure Step Service SOP Class

When the Sequoia captures the 1<sup>st</sup> image in a study, the Sequoia will send a N-CREATE service request. When the study is ended, Sequoia will send a N-SET service request.

The following table provides the list of attributes requested in the Modality Performed Procedure Step:

Table 3.1.2.5.2-1 MPPS Information Model Attributes  
N-CREATE Service Request (Study Start with first image capture)

Description/Module	Tag	Value Description
<b>Performed Procedure Step Relationship</b>		
Scheduled Step Attribute Sequence	(0040,0270)	
>Study Instance UID	(0020,000D)	From MWL or created by Sequoia
>Referenced Study Sequence	(0008,1110)	Set to NULL
>Accession Number	(0008,0050)	From MWL or user input at Sequoia Begin Screen
>Requested Procedure ID	(0040,1001)	From MWL
>Requested Procedure Description	(0032,1060)	
>Scheduled Procedure Step ID	(0040,0009)	Empty
>Scheduled Procedure Description	(0040,0007)	Empty
>Scheduled Action Item Code Sequence	(0040,0008)	Set to NULL
Patient's Name	(0010,0010)	
Patient's ID	(0010,0020)	
Patient's Birth Date	(0010,0030)	
Patient Sex	(0010,0040)	
Referenced Patient Sequence	(0008,1120)	Set to NULL
<b>Performed Procedure Step Information</b>		
Performed Procedure Step ID	(0040,0253)	The value will be the same as the Study Description tag (0008,1030)
Performed Station AE Title	(0040,0241)	Set to Sequoia's AE Title
Performed Station Name	(0040,0242)	Set to Sequoia's host name
Performed Location	(0040,0243)	Set to NULL
Performed Procedure Step Start Date	(0040,0244)	
Performed Procedure Step Start Time	(0040,0245)	
Performed Procedure Step Status	(0040,0252)	Set to "INPROGRESS"
Performed Procedure Step Description	(0040,0254)	The value will be the same as the Study Description tag (0008,1030)
Performed Procedure Type Description	(0040,0255)	Set to NULL
Procedure Code Sequence	(0008,1032)	Set to NULL
Performed Procedure Step End Date	(0040,0250)	Set to NULL
Performed Procedure Step End Time	(0040,0251)	Set to NULL
<b>Image Acquisition Results</b>		
Modality	(0008,0060)	Set to "US"
Study ID	(0020,0010)	The value will be the same as the Study Description tag (0008,1030)
Performed Action Item Code Sequence	(0040,0260)	Set to NULL
Performed Series Sequence	(0040,0340)	Set to NULL

Table 3.1.2.5.2-2 MPPS Information Model Attributes  
N-Set Service Request (Study End)

Description/Module	Tag	Value Description
<b>Performed Procedure Step Information</b>		
Performed Procedure Step Status	(0040,0252)	Set to "COMPLETED"
Performed Procedure Step End Date	(0040,0250)	
Performed Procedure Step End Time	(0040,0251)	
<b>Image Acquisition Results</b>		
Performed Series Sequence	(0040,0340)	
>Performing Physician's Name	(0008,1050)	Set to NULL
>Protocol Name	(0018,1030)	The value will be the same as the Study Description tag (0008,1030)
>Operator's Name	(0008,1070)	
>Series Instance UID	(0020,000E)	
>Series Description	(0008,103E)	The value will be the same as the Study Description tag (0008,1030)
>Retrieve AE Title	(0008,0054)	Set to storage server's AE Title
>Referenced Image Sequence	(0008,1140)	One for each clip/image
>>Referenced SOP Class UID	(0008,1150)	
>>Referenced SOP Instance UID	(0008,1155)	
>Referenced Stand-alone SOP Sequence	(0040,0220)	One for SR Object
>>Referenced SOP Class UID	(0008,1150)	
>>Referenced SOP Instance UID	(0008,1155)	

### 3.1.2.6 Real World Activity – Storage Commitment

#### 3.1.2.6.1. Proposed Presentation Context

Table 3.1.2.6.1-1 Storage Commitment Presentation Context Table

<b>Presentation Context Table</b>					
<b>Abstract Syntax</b>		<b>Transfer Syntax</b>		<b>Role</b>	<b>Extended Negotiation</b>
<b>Name</b>	<b>UID</b>	<b>Name List</b>	<b>UID List</b>		
Storage Commitment Push Model	1.2.840.10008.1.20.1	DICOM Implicit VR Little Endian	1.2.840.10008.1.2	SCU	None

#### 3.1.2.6.2. Storage Commitment Service SOP Class

The following table provides the list of attributes supported by the AE in the implementation of Storage Commitment SOP Class including N-ACTION, N-EVENT-REPORT, and File State attributes.

Table 3.1.2.6.2-1 Storage Commitment – Action Information

Action Type Name	Action Type ID	Attribute	Tag	Description
Request Storage Commitment	1	Transaction UID	(0008,1195)	Sequoia Generated UID
		Reference SOP Sequence	(0008,1199)	
		>Referenced SOP Class UID	(0008,1150)	SOP Class UID for each object stored
		>Referenced SOP Instance UID	(0008,1155)	SOP Instance UID for each object stored

Table 3.1.2.6.2-2 Storage Commitment – Event Report Information

Action Type Name	Action Type ID	Attribute	Tag	Description
Storage Commitment Request Successful	1	Transaction UID	(0008,1195)	
		Reference SOP Sequence	(0008,1199)	
		>Referenced SOP Class UID	(0008,1150)	
		>Referenced SOP Instance UID	(0008,1155)	
Storage Commitment Request Complete Failures Exist	2	Retrieve AE Title	(0008,0054)	
		Transaction UID	(0008,1195)	
		Reference SOP Sequence	(0008,1199)	
		>Referenced SOP Class UID	(0008,1150)	
		>Referenced SOP Instance UID	(0008,1155)	
		Failed SOP Sequence	(0008,1198)	
		>Referenced SOP Class UID	(0008,1150)	
>Referenced SOP Instance UID	(0008,1155)			

### 3.1.2.7 Real World Activity – MOD Media Interchange

The images that are stored on MO follow the same DICOM Image IOD specification as implemented in the DICOM 3.0 standard, Part 3 (see Table 3.1.2.2.3-1).

#### 3.1.2.7.1. Ultrasound Application Profile

Table 3.1.2.7.1-1 DICOM Ultrasound Application Profiles

Application Profile	Real-World Activity	Role
STD-US-SF-MOD128	Create MO	FSC, [FSU*, FSR*]
STD-US-MF-MOD128	Create MO	FSC, [FSU*, FSR*]
STD-US-SF-MOD230	Create MO	FSC, [FSU*, FSR*]
STD-US-MF-MOD230	Create MO	FSC, [FSU*, FSR*]
STD-US-SF-MOD540	Create MO	FSC, [FSU*, FSR*]
STD-US-MF-MOD540	Create MO	FSC, [FSU*, FSR*]
STD-US-SF-MOD640	Create MO	FSC, [FSU*, FSR*]
STD-US-MF-MOD640	Create MO	FSC, [FSU*, FSR*]

\*Updater/Reader only applicable to Sequoia & Aspen systems

### 3.1.2.7.2. Proposed Presentation Context

Table 3.1.2.7.2-1 MOD Media Interchange Presentation Context Table

Abstract Syntax		Transfer Syntax	
Name	UID	Name List	UID List
Ultrasound Image	1.2.840.10008.5.1.4.1.1.6.1	RLE Lossless	1.2.840.10008.1.2.5
Ultrasound Multi-frame Image Storage	1.2.840.10008.5.1.4.1.1.3.1	JPEG Baseline	1.2.840.10008.1.2.4.50
DICOM Media Storage Directory	1.2.840.10008.1.3.10	Explicit VR Little Endian	1.2.840.10008.1.2.1

## 4. Communication Profiles

### 4.1 TCP/IP Stack Supported

This implementation supports TCP/IP Protocol stack. OSI stack is not supported. This implementation is indifferent to the underlying physical medium. It only requires TCP/IP in the Transport and Network layers. Port number 2100 is used for DICOM communication with the Sequoia.

### 4.2 Physical Media Supported

Standard representation of IEEE 802.3 (10BaseT “twisted pair”) is supported and the system interfaces and transceivers configured to meet customer site-specific requirements.

## 5. Data Identification Information

Patient and image data originated from an Sequoia system can be identified by the Study Instance UID, Series Instance UID and SOP Instance UID, i.e., DICOM elements (0020, 000D), (0020, 000E) and (0008, 0018) in the IOD.

- Sequoia UID root is 1.2.840.113680.1.103  
where:  
1.2.840.113680 is the ANSI registered Acuson UID root.
- The Study Instance UID is composed using the following convention:  
1.2.840.113680.1.103.n.s.t  
where  
n = serial number of the Sequoia machine  
s = the UNIX epoch based time since a base time in seconds  
t = microsecond within the second of current UNIX epoch-base time

- The Series Instance UID is composed of the Study Instance UID and the series number:  
1.2.840.113680.1.103.n.s.t.r  
where  
r = 1 for full-screen static and dynamic and quarter-size static images  
r = 2 for quarter-screen dynamic image
- The SOP Instance UID is composed of the Series Instance UID and the image number:  
1.2.840.113680.1.103.n.s.t.r.f  
where  
f = image number

## 6. Extensions, Specializations and Privatizations

### 6.1 Private DICOM Elements

There are many DICOM Private tags used in Sequoia proprietary files internal to Sequoia software for image acquisition and image review on the Sequoia system and in the private Structured Report SOP object.

These can be exported to servers as part of the Store SCU AE configuration on the Sequoia system. They are also exported to removable MOD:

- ACQ\_SET file: acquisition protocol and acquired image set information.  
DICOM Private Elements, primarily (0009,xxxx)
- DSP\_SET file: image set selected for display.
- CLIPS/IMAGES: Sequoia image data  
Acuson private elements (7FDF, xxxx) in “Explicit VR Big Endian” file format
- CALC\_SR: Sequoia measurements, calculations and findings for Cardiac, OB, and Vascular reports.  
Various Acuson private, LOINC, and SNOMED elements

## 7. Configuration

The Sequoia Service User Interface database maintains configuration parameters for remote and local DICOM Application Entities. The parameters include:

- AE identification, i.e., a descriptive name
- Calling AE Title, IP address, and TCP port number (for Sequoia DICOM SCU)
- Called AE Title (for a remote SCP)
- TCP port number (for a remote SCP)
- IP address or host name (for a remote host where the remote SCP resides)
- DICOM print parameters for a DICOM print SCP entry
- Printer templates
- Some specialized information

This configuration database can be copied via a service MO to other Sequoia machines on the network.

The local DICOM applications read information from this database. The DICOM Network configuration tool is the only application that can modify this database.

## 8. Support of Extended Character Sets

The following character set is supported:

ISO-IR 100 Latin Alphabet No. 1

## 9. References

- Digital Imaging and Communication in Medicine (DICOM), NEMA Standard Publication No. PS 3.1~3.13, NEMA, 1300 North 17th Street, Suite 1847, Rosslyn, VA 22209, phone: (703)-841-3200.
- World Wide Web: <http://www.nema.org/medical/dicom.htm>

## 10. Glossary

ACR	American College of Radiology
AE	Application Entity
ANSI	American National Standards Institute
DICOM	Digital Imaging and Communication in Medicine
DIMSE-C	DICOM Message Service Element-Composite
DIMSE-N	DICOM Message Service Element-Normalized
FSC	File-set Creator
FSR	File-set Reader
FSU	File-set Updater
HIS/RIS	Hospital Information System/Radiology Information System
IOD	Information Object Definition
ISO	International Standards Organization
MOD	Magneto-Optical Disk
NEMA	National Electrical Manufacturers Association
OSI	Open Systems Interconnections
PDU	Protocol Data Unit
SCP	Service Class Provider (server)
SR	Structured Report
SCU	Service Class User (client)
TCP/IP	Transmission Control Protocol/Internet Protocol
SOP	Service Object Pair
UID	Unique Identification