

**Acuson**

**Sequoia™ Ultrasound System**

**DICOM Conformance Statement**

**(for Sequoia 3.0, 3.15 and 3.16)**

## 1. Document History

Rev	Date	Author	Comments
1	8/10/98	JB Wang	Created
2	8/11/98	JB Wang	Incorporated comments from Paul Spadafora
3	8/19/98	JB Wang	Correct Implementation UID/Name errors
4	7/1/99	JB Wang	Updated Sequoia version numbers

## 2. Introduction

This document is a DICOM 3.0 Conformance Statement for the Acuson Sequoia Ultrasound System releases 3.0, 3.15 and 3.16. The DICOM conformance for other medical devices manufactured by Acuson is not included in this document.

The following DICOM 3.0 functions are supported in Sequoia 3.0.

1. Verifying DICOM 3.0 connectivity using Verification service class SCU.
2. Exporting images using DICOM 3.0 Storage service class SCU.
3. Printing images using DICOM 3.0 Print management service class SCU.
4. 90mm (3.5") 128MB and 230MB DICOM MOD media.

### 2.1. Source of Information

- Digital Imaging and Communication in Medicine (DICOM), NEMA Standard Publication No. PS 3.1~3.13, NEMA, 1300 North 17th Street, Suite 1847, Rosslyn, VA 22209, phone: (703)-841-3200.
- World Wide Web: <http://www.nema.org/medical/dicom.htm>

## 2.2. Acronyms and Abbreviations

ACR	American College of Radiology
AE	Application Entity
ANSI	American National Standards Institute
DICOM	Digital Imaging and Communication in Medicine
DIMSE-C	DICOM Message Service Element-Composite
DIMSE-N	DICOM Message Service Element-Normalized
FSC	File-set Creator
FSR	File-set Reader
FSU	File-set Updator
IOD	Information Object Definition
ISO	International Standards Organization
MOD	Magneto-Optical Disk
NEMA	National Electrical Manufacturers Association
OSI	Open Systems Interconnections
PDU	Protocol Data Unit
SCP	Service Class Provider (server)
SCU	Service Class User (client)
TCP/IP	Transmission Control Protocol/Internet Protocol
SOP	Service Object Pair
UID	Unique Identification

## 3. Implementation Model

Each DICOM function is an Application Entity (AE).

### 3.1. Application Data Flow Diagram

#### 3.1.1. Verification AE

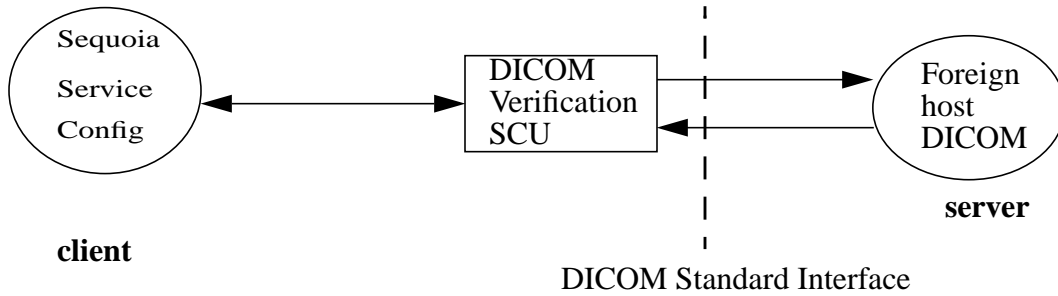

#### 3.1.2. Image Export AE

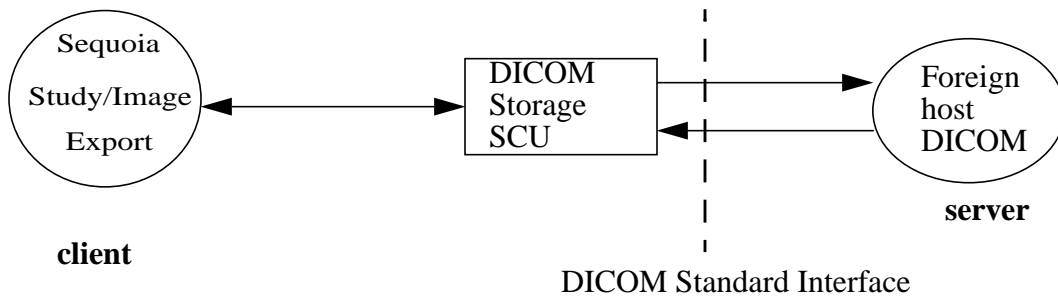

#### 3.1.3. DICOM Printing AE

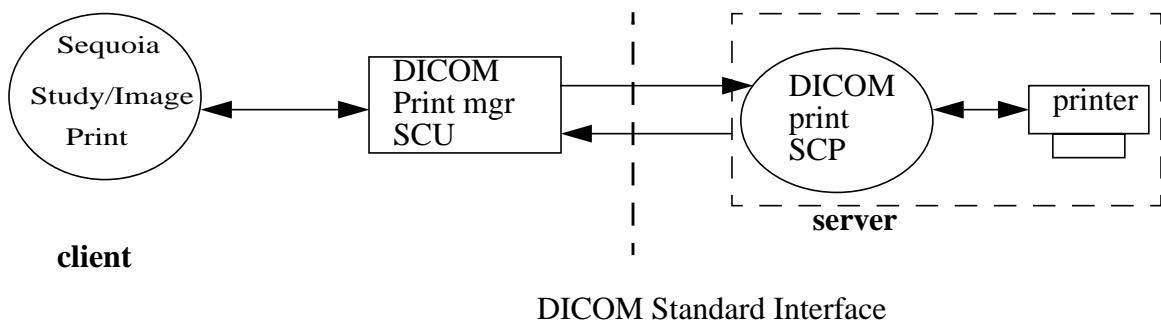

### 3.1.4. DICOM MOD Media Interchange AE

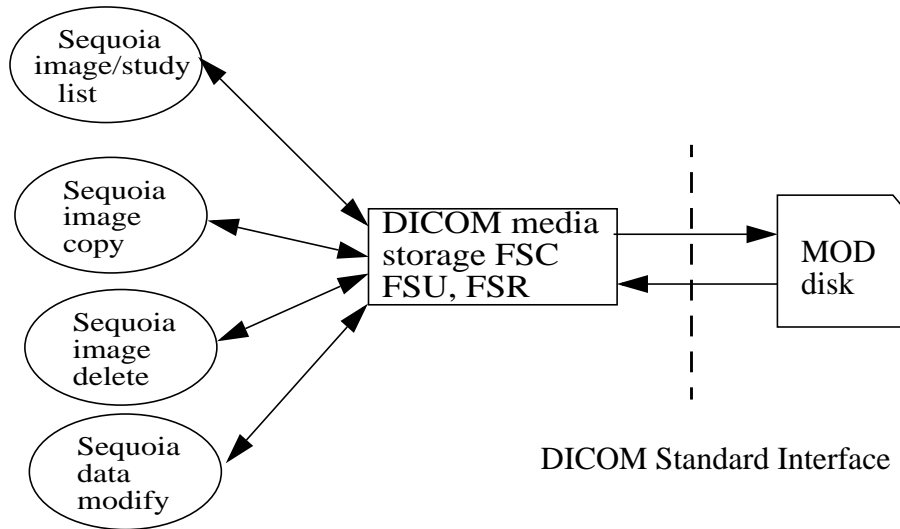

## 3.2. Functional Definitions of AE

### 3.2.1. Verification AE

The Verification AE is part of the DICOM configuration tool. It issues a DICOM 3.0 verification request to the remote DICOM server and tries to receive a response (if any) and reports the result.

The result can be either of the following.

1. Success
2. Rejected
3. Time-out

The Calling AE Title and Called AE Title are identical to those used in the Image Export or Print AE.

### 3.2.2. Image Export AE

The Image Export AE uses DICOM 3.0 Storage service class SCU to export Sequoia single frame and multi-frame Ultrasound images to a host which supports the SCP role of Storage service class.

The user can export the images acquired so far in the current study or use the UI to select completed studies and export them.

The storage destination can be set at run-time.

### **3.2.3. Image Print AE**

The Image Print AE uses DICOM 3.0 Print management service class SCU to print Sequoia single frame Ultrasound images to a network DICOM printer.

The user can print images acquired so far in the current study or use the UI to select completed studies and prints them.

The destination printers are user configurable at setup time.

### **3.2.4. DICOM MOD Media Interchange AE**

The DICOM MOD Media Interchange AE performs the following DICOM roles:

- File-set creator (FSC): it creates a DICOM MOD medium when the user copies studies/images to MO. A DICOM 3.0 conforming DICOMDIR file is created along with the directory structures and image files.
- File-set updatator (FSU): it modifies the DICOMDIR file and image files when the user copies or deletes studies/images.
- File-set reader (FSR): it reads the DICOMDIR and makes a listing. It also reads and display images when the user chooses to do so.

Studies/images are copied to MOD if the user uses Study Util UI to select studies and copy them to MOD.

Studies/images are copied from MOD into the system if the user uses Study Util UI to select studies and copy them from MOD.

Images are read and displayed if the user uses Study Util UI to select a study for review. The DICOMDIR file is read and parsed by Study Util to generate the study listing.

Limitations:

- Only Acuson Aspen and Sequoia studies can be copied to and from MOD. A MOD can contain mixed Aspen and Sequoia studies.
- Only Acuson Aspen and Sequoia studies can be reviewed on Sequoia.
- The Aspen release version must be 3.0 or greater. The Sequoia release version must be 1.0 or greater.

The level of compatibility of Sequoia 3.0 DICOM MOD with a non-Acuson DICOM 3.0 reader must be assessed by the maker of the reader.

### **3.3. Sequencing of Real World Activities**

See the previous section.

## 4. Network Transfer Specifications

### 4.1. Supported SOP Classes

This implementation provides standard conformance to the following DICOM 3.0 SOP classes.

TABLE 1. Verification SOP Class

SOP Class Name	SOP Class UID	Role
Verification SOP Class	1.2.840.10008.1.1	SCU

TABLE 2. Storage SOP Classes

SOP Class Name	SOP Class UID	Role
Ultrasound Image	1.2.840.10008.5.1.4.1.1.6 (retired)	SCU
	1.2.840.10008.5.1.4.1.1.6.1	
Multi-frame Ultrasound Image	1.2.840.10008.5.1.4.1.1.3 (retired)	SCU
	1.2.840.10008.5.1.4.1.1.3.1	

TABLE 3. Print Management SOP Class

SOP Class Name	SOP Class UID	Role
Basic Grayscale Print Management Meta	1.2.840.10008.5.1.1.9	SCU
Basic Color Print Management Meta	1.2.840.10008.5.1.1.18	SCU

### 4.2. Association Establishment Policies

#### 4.2.1. General

The maximum PDU size is configurable and negotiable. The default PDU size is 32768 8-bit bytes.

#### 4.2.2. Number of Associations

Multiple associations can be opened for the same or different types of transactions. The maximum number of simultaneous associations is 10.

### 4.2.3. Asynchronous Nature

This implementation does not support Asynchronous operation.

### 4.2.4. Implementation Identifying Information

This implementation will be identified by

- Implementation Class UID = 1.2.840.113680.15.1
- Implementation Version Name = DS15.1\_

### 4.2.5. Calling and Called AE Titles

The SCU Calling AE Title is pre-configured at the installation time to be:

- SEQUOIA\_serial#

The user can change it if needed.

The Called AE Title is used by a SCP. This release does not contain a SCP.

## 4.3. Association Initiation Policy

This implementation will initiate the association in the following manner.

- The Verification will open one association. It is closed at the end of the transaction.
- In Storage SCU, Sequoia opens one association per study.
- DICOM print will open one association per film session.

### 4.3.1. Proposed Presentation Context

TABLE 4. Proposed Presentation Contexts for Sending Data/Request

Presentation Context (SCU)					
Abstract Syntax		Transfer Syntax		Role	Extended Negotiation
SOP Name	UID	Name list	UID list		
Tables 1~3	Tables 1~3	Implicit VR Little Endian	1.2.840.10008.1.2	SCU	None
Ultrasound Image	Table 2	RLE Loss-less Image Compression	1.2.840.10008.1.2.5	SCU	None
Multi-frame Ultrasound Image	Table 2	JPEG Baseline	1.2.840.10008.1.2.4.50	SCU	None

### 4.3.2. SOP Specific Conformance of SCU

#### 4.3.2.1. Storage SOP Classes: Presentation Contexts

The Image Export AE is implemented in such a way that it negotiates with the peer AE the 6 possible presentation contexts as listed in Table 6 during the association.

It selects the SOP Class UID according to the scheme in Table 5. It composes one presentation context for exporting single frame images and one for multi-frame ones based on the selected SOP Class UID and Table 6.

TABLE 5. Storage SCU SOP Class UID Selection Scheme

Image Type	Selection order: SOP Class UID
Single Frame Ultrasound Image	1.2.840.10008.5.1.4.1.1.6.1 (new)
	1.2.840.10008.5.1.4.1.1.6 (retired)
Multi-frame Ultrasound Image	1.2.840.10008.5.1.4.1.1.3.1 (new)
	1.2.840.10008.5.1.4.1.1.3 (retired)

TABLE 6. Storage SCU Presentation Context Selection Scheme

SOP Class UID	Selection order: Transfer Syntax UID
1.2.840.10008.5.1.4.1.1.6.1	1.2.840.10008.1.2.5 (RLE)
	1.2.840.10008.1.2 (DICOM default)
1.2.840.10008.5.1.4.1.1.6	1.2.840.10008.1.2.5 (RLE)
	1.2.840.10008.1.2 (DICOM default)
1.2.840.10008.5.1.4.1.1.3.1	1.2.840.10008.1.2.4.50 (JPEG Baseline)
	1.2.840.10008.1.2 (DICOM default)
1.2.840.10008.5.1.4.1.1.3	1.2.840.10008.1.2.4.50 (JPEG Baseline)
	1.2.840.10008.1.2 (DICOM default)

Sequoia sends SOP class UID and transfer syntax UID pairs to negotiate for the supported presentation contexts, i.e.,

SOP class UID 1 and Transfer Syntax UID 1

SOP class UID 1 and Transfer Syntax UID 2

SOP class UID 2 and Transfer Syntax UID 1

...

This may pose problems to servers that can only recognize the following method of grouping:

SOP class UID 1 and Transfer Syntax UID 1, Transfer Syntax UID 2

SOP class UID 2 and Transfer Syntax UID 1, ...

#### 4.3.2.2. Storage SOP Classes: Photometric Interpretation

Photometric Interpretation, i.e., color mode of the pixel image data, is not a negotiable parameter in DICOM 3.0.

This implementation exports color images in RGB mode and grayscale images in monochrome 2 if the peer AE only accepts uncompressed Implicit VR Little Endian transfer syntax. Images will be exported in a YBR color mode if either RLE or JPEG transfer syntax is used (see Table 7.)

TABLE 7. Photometric Interpretation of Exported Images

Ultrasound image SOP Class UID	Transfer Syntax and UID	Image Content	Photometric Inter- pretation
Single-frame: 1.2.840.10008.5.1.4.1.1.6.1 1.2.840.10008.5.1.4.1.1.6	Implicit VR Little Endian 1.2.840.10008.1.2	B/W	MONOCHROME2
Multi-frame: 1.2.840.10008.5.1.4.1.1.3.1 1.2.840.10008.5.1.4.1.1.3		Color	RGB
Single-frame: 1.2.840.10008.5.1.4.1.1.6.1	RLE Lossless Image Compression 1.2.840.10008.1.2.5	B/W or Color	YBR_FULL
Multi-frame: 1.2.840.10008.5.1.4.1.1.3.1	JPEG Baseline 1.2.840.10008.1.2.4.50	B/W or Color	YBR_FULL_422

#### 4.3.2.3. Storage SOP Classes: DICOM IOD Specification

This implementation uses DICOM 3.0 Part 3 and Supplement 5 as the DICOM Image IOD specification.

All the Type 1 and 2 elements specified in the DICOM 3.0 standard are encoded and exported. Some Type 3, 1C and 2C elements are also exported.

#### 4.3.2.4. Print SOP Class

The Sequoia DICOM configuration tool allows the user to configure the following printer parameters. The actual allowable values should be determined by reading the DICOM 3.0 Conformance Statement of the printer.

TABLE 8. User Configurable Print Parameters

Parameter	Tag	Editable Values
Medium Type	(2000, 0030)	PAPER   <b>BLUE FILM</b>   CLEAR FILM
Display Format	(2010, 0010)	STANDARD\1,1   STANDARD\1,2   STANDARD\2,2   <b>STANDARD\2,3</b>   STANDARD\3,2   STANDARD\3,3   STANDARD\4,4   STANDARD\4,5   STANDARD\5,6
Film Size ID	(2010, 0050)	<b>8INX10IN</b>   14INX17IN   10INX12IN   10INX14IN   11INX14IN   14INX14IN   24CMX24CM   24CMX30CM
Photometric Interpretation	(0028, 0004)	RGB (Colored)   MONOCHROME1 (Reverse Video)   <b>MONOCHROME2</b> (B/W)

Except the color mode, i.e., Photometric Interpretation, none of these parameters are negotiable by the DICOM 3.0 standard. Images will not be printed, for instance, if the user chooses a Display Format that the printer does not support.

Sequoia will automatically re-negotiate for grayscale printing if the color mode is not supported.

#### 4.4. Association Acceptance Policy

This implementation does not accept an association request.

#### 4.5. Communication Profile

This implementation supports TCP/IP Protocol stack.

OSI stack is not supported.

DICOM 50-pin physical connection is not supported.

This implementation is indifferent to the underlying physical medium. It only requires TCP/IP in the Transport and Network layers.

## 5. Removable Media Interchange Specifications

This implementation supports two 3.5” DICOM MOD removable media. It conforms to DICOM 3.0 Part 10, 11 and 12.

### 5.1. Supported SOP Classes

This implementation provides standard conformance to the following DICOM 3.0 SOP classes.

TABLE 9. Media Storage SOP Classes

SOP Class Name	SOP Class UID	Roles
Ultrasound Image	1.2.840.10008.5.1.4.1.1.6.1	FSC
Multi-frame Ultrasound Image	1.2.840.10008.5.1.4.1.1.3.1	FSU FSR
DICOM Media Storage Directory	1.2.840.10008.1.3.10	

#### 5.1.1. Proposed Transfer Syntaxes

TABLE 10. Proposed Transfer Syntaxes for Media Interchange

Abstract Syntax		Transfer Syntax	
SOP Name	UID	Name list	UID list
Ultrasound Image	Table 9	RLE Loss-less Image Compression	1.2.840.10008.1.2.5
Multi-frame Ultrasound Image	Table 9	JPEG Base-line	1.2.840.10008.1.2.4.50
DICOM Media Storage Directory	Table 9	Explicit VR Little Endian	1.2.840.10008.1.2.1

#### 5.1.2. Physical Storage Media and Media Formats

The physical storage media are 90mm (3.5”) 128MB and 230MB magneto-optical disks.

The disks are formatted in PC (DOS) file system format.

## 6. Data Identification Information

Patient and image data originated from an Sequoia system can be identified by the Study Instance UID, Series Instance UID and SOP Instance UID, i.e., DICOM elements (0020, 000D), (0020, 000E) and (0008, 0018) in the IOD.

- Sequoia UID root is 1.2.840.113680.1.103, where 1.2.840.113680 is the ANSI registered Acuson UID root.
- The Study Instance UID is composed using the following convention:

1.2.840.113680.1.103.n.s.t

where

n = serial number of the Sequoia machine

s = the UNIX epoch based time since a base time in seconds

t = microsecond within the second of current UNIX epoch-base time

- The Series Instance UID is composed of the Study Instance UID and the series number:

1.2.840.113680.1.103.n.s.t.r

where

r = 1 for full-screen static and dynamic and quarter-size static images

r = 2 for quarter-screen dynamic images

- The SOP Instance UID is composed of the Series Instance UID and the image number:

1.2.840.113680.1.103.n.s.t.r.f

where

f = image number

## 7. Extensions, Specializations and Privatizations

The private elements and files listed in this section are primarily intended for Acuson internal use.

## 7.1. Private DICOM Elements

The Acuson private group (7FDF, xxxx) is used in DICOM image IOD files.

TABLE 11. Acuson Private DICOM Elements

Element Name	Tag	VR	VM	Description
Private Creator	7FDF, 0010	LO	1	To reserve element tags 1000-10FF, value set to ACUSON: 1.2.840.11386.0.1.0
Lossy Compression Ratio	7FDF, 1000	IS	1	JPEG compression ratio
Image Format	7FDF, 1001	US	1	01H = STATIC 05H = FULL SIZE CLIP 06H = 1/4 SIZE CLIP 07H = 1/4 SIZE ROI CLIP
Acuson Region Type	7FDF, 1002	US	1	01H = PATIENT IDENTIFIER 02H = USEFUL DISPLAY 03H = ACQ IMAGE NUMBER
Acuson Image Apex X	7FDF, 100B	UL	1	X coordinate of pair defining location of a virtual image apex
Acuson Image Apex Y	7FDF, 100C	UL	1	Y coordinate of pair defining location of a virtual image apex
B-Color-On Flag	7FDF, 100D	IS	1	0 = B-COLOR absent 1 = B-COLOR present
Data Padding	7FDF, FE00	OB	1	It is a padding element before pixel data to allow the DICOM header elements to grow and shrink.

## 7.2. Private Files

There are a few Acuson private files in DICOM MOD study directories. These files are in a semi-proprietary “Explicit VR Big Endian” file format.

1. DBRECORD file: patient demographic and study information that apply to all the images in the study.
2. ACQ\_SET file: acquisition protocol and acquired image set information.

3. DSP\_SET file: image set selected for display.

Many private DICOM elements are used in these files. They are not documented here because they are only used internally by Acuson software during image acquisition.

A non-Acuson DICOM reader should not attempt to parse these private files. All the DICOM supported data are already in the DICOMDIR and DICOM image files.

## **8. Configuration**

The Sequoia Service User Interface database maintains configuration parameters of remote and local DICOM Application Entities. The parameters include:

- AE identification, i.e., a descriptive name
- Calling AE Title (for Sequoia DICOM SCU)
- Called AE Title (for a remote SCP)
- TCP port number (for a remote SCP)
- IP address or host name (for a remote host where the remote SCP resides)
- DICOM print parameters for a DICOM print SCP entry
- Some specialized information

This configuration database can be copied to other Sequoia machines on the network via a MO disk.

The local DICOM applications read information from this database. DICOM configuration tool is the only application that can modify this database.

## **9. Support of Extended Character Sets**

The following character set is supported:

ISO-IR 100 Latin Alphabet No. 1

## **10. Comments**

Acuson is an active member on the ACR-NEMA DICOM standards committee. Acuson is striving to make DICOM a better standard for our customers.



## Approval for Sequoia 3.0 DICOM Conformance Statement

_____ Engineering	_____ Date
_____ General Imaging Business Unit	_____ Date
_____ Cardiology Business Unit	_____ Date
_____ International Business Unit	_____ Date
_____ Regulatory	_____ Date
_____ Legal	_____ Date
_____ DICOM Czar	_____ Date

