

**Acuson**

**Sequoia™ Ultrasound System**

**DICOM Conformance Statement**

**(for Sequoia 4.0 and 5.0)**

## 1. Document History

Rev	Date	Author	Comments
1	8/10/98	JB Wang	Created
2	8/11/98	JB Wang	Incorporated comments from Paul Spadafora
3	8/19/98	JB Wang	Correct Implementation UID/Name errors
4	1/18/99	A Goldner	Updated for Sequoia 4.1 functionality
5	6/29/99	Paul Spadafora	Minor updates for Sequoia 4.0
6	7/1/99	JB Wang	Updated Sequoia version numbers
7	2/16/2000	JB Wang	Updated for Sequoia 5.x

## 2. Introduction

This document is a DICOM 3.0 Conformance Statement for the Acuson Sequoia Ultrasound System releases 4.0 and 5.x. The DICOM conformance for other medical devices manufactured by Acuson is not included in this document.

The following DICOM 3.0 functions are supported in Sequoia 4.0 and 5.x.

1. Verifying DICOM 3.0 connectivity using Verification service class SCU.
2. Exporting images using DICOM 3.0 Storage service class SCU.
3. Printing images using DICOM 3.0 Print management service class SCU.
4. Querying patient and study scheduling information using DICOM 3.0 Modality Worklist service class SCU.
5. Updating the status of a particular procedure step of study using DICOM 3.0 Modality Performed Procedure Step service class SCU.
6. Notifying images sent through the DICOM 3.0 Storage Commitment Push SOP Class.
7. 90mm (3.5") 128MB and 230MB DICOM MOD media.

### 2.1. Source of Information

- Digital Imaging and Communication in Medicine (DICOM), NEMA Standard Publication No. PS 3.1~3.13, NEMA, 1300 North 17th Street, Suite 1847, Rosslyn, VA 22209, phone: (703)-841-3200.
- World Wide Web: <http://www.nema.org/nema/dicom/>

## 2.2. Acronyms and Abbreviations

ACR	American College of Radiology
AE	Application Entity
ANSI	American National Standards Institute
DICOM	Digital Imaging and Communication in Medicine
DIMSE-C	DICOM Message Service Element-Composite
DIMSE-N	DICOM Message Service Element-Normalized
FSC	File-set Creator
FSR	File-set Reader
FSU	File-set Updator
IOD	Information Object Definition
ISO	International Standards Organization
MOD	Magneto-Optical Disk
MPPS	Modality Performed Procedure Step
NEMA	National Electrical Manufacturers Association
OSI	Open Systems Interconnections
PDU	Protocol Data Unit
SCP	Service Class Provider (server)
SCU	Service Class User (client)
TCP/IP	Transmission Control Protocol/Internet Protocol
SOP	Service Object Pair
UID	Unique Identification

## 3. Implementation Model

Each DICOM function is an Application Entity (AE).

### 3.1. Application Data Flow Diagram

#### 3.1.1. Verification AE

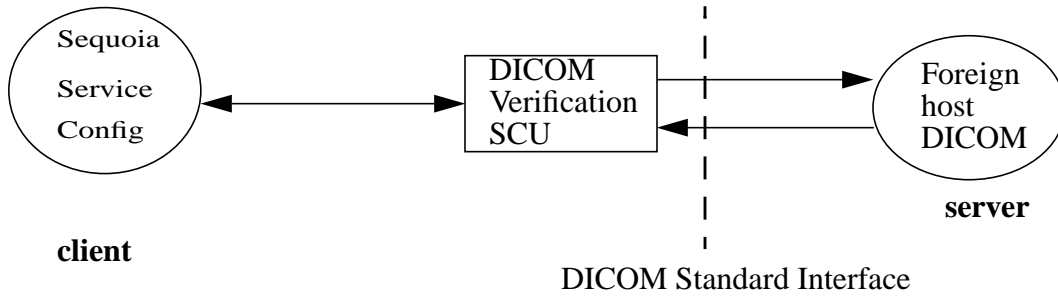

#### 3.1.2. Image Export AE

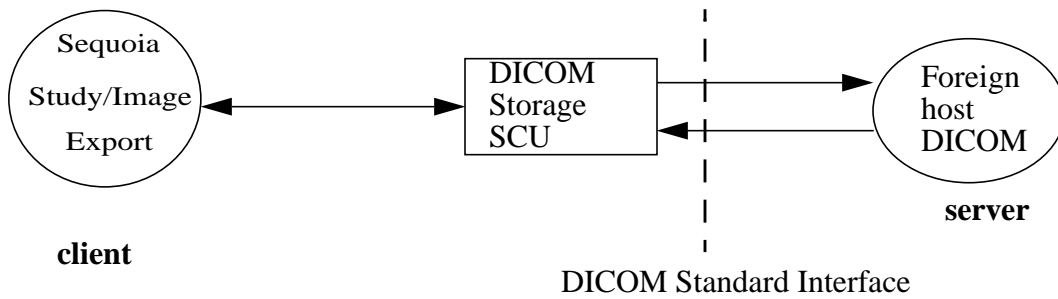

#### 3.1.3. DICOM Printing AE

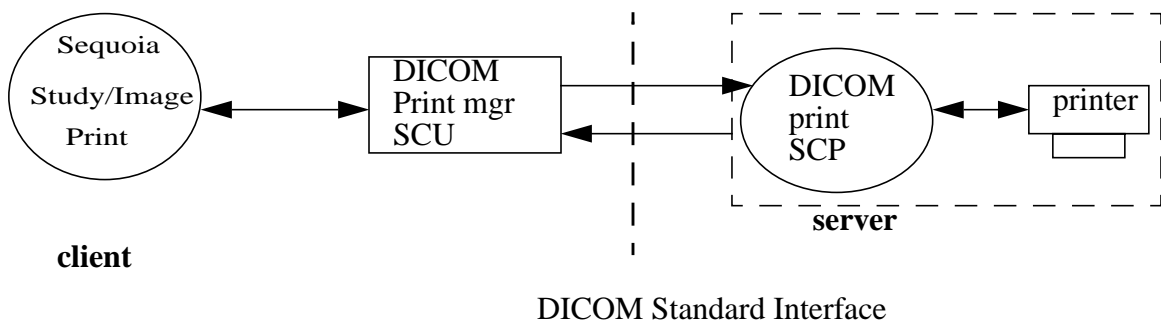

**3.1.4. DICOM Modality Worklist AE**

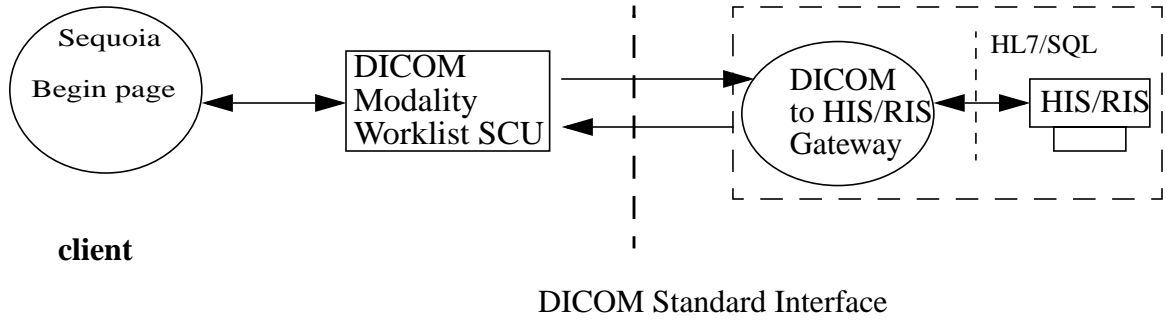

**3.1.5. DICOM Modality Performed Procedure Step AE**

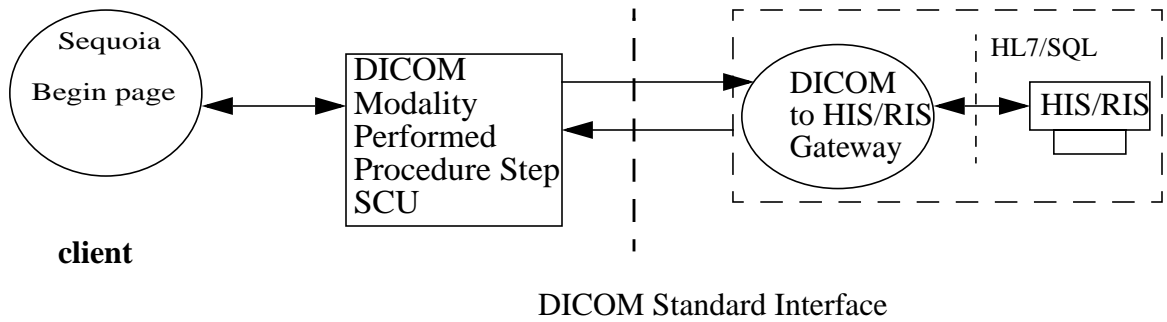

**3.1.6. DICOM MOD Media Interchange AE**

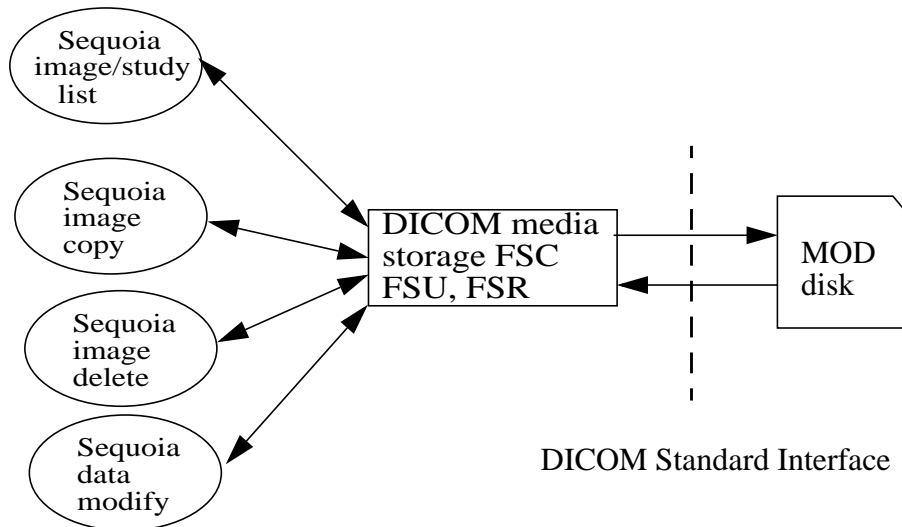

## **3.2. Functional Definitions of AE**

### **3.2.1. Verification AE**

The Verification AE is part of the DICOM configuration tool. It issues a DICOM 3.0 verification request to the remote DICOM server and tries to receive a response (if any) and reports the result.

The result can be either of the following.

1. Success
2. Rejected
3. Time-out

The Calling AE Title and Called AE Title are identical to those used in the Image Export or Print AE.

### **3.2.2. Image Export AE**

The Image Export AE uses DICOM 3.0 Storage service class SCU to export Sequoia single frame and multi-frame Ultrasound images to a host which supports the SCP role of Storage service class.

In this release, the user can still manually use the Study Util UI to select completed studies and export them. The destination is set at run-time.

Additionally, two background image export methods are added. The user can now either,

- let the system automatically export images as soon as each image is captured and saved while the study is in-progress, or
- let the system automatically export all the images belonging to the study as soon as the study is closed.

The former is a good way to distribute the network load over time and access images from the review station near real-time. The latter lets the user have cleaner studies in the server. It is a common practice in Ultrasound to delete some useless images or modify demographic data before the study is closed.

To use background export, the user needs to use Aegis System Wide Function set-up UI under “code-setup” to configure the destinations and mode. Images can be copied to the two destinations simultaneously.

### **3.2.3. Image Print AE**

The Image Print AE uses DICOM 3.0 Print management service class SCU to print Sequoia single frame Ultrasound images to a network DICOM printer.

The user can print images acquired so far in the current study or use the UI to select completed studies and prints them.

In this release, the user selects completed studies and prints them. The destination printers, one B&W and one color, are user configurable at setup time.

Two background printing methods are added. The user can now either,

- let the system automatically print films as soon as each film is filled with newly the captured images while the study is in-progress, or
- let the system automatically print all the films belonging to the study as soon as the study is closed. Since the user may delete some images before closing the study, this method will give cleaner printouts.

Since it can take 30 seconds to 6 minutes to print a film, the former will let the user see most of the films before the study is closed. The user can press “Print Now” to force a film to be printed before it is fully populated with images.

#### **3.2.4. DICOM Modality Worklist AE**

DICOM Modality Worklist AE is embedded in the Sequoia Begin page (or demographic page) application.

This AE uses DICOM Modality Worklist SCU to query a Radiology/Cardiology/Hospital Information System, often via a DICOM to HL7 gateway, to obtain patient demographic and study scheduling information. The information is then used to populate the Begin page, so that the operator does not need to type in patient name, birth date, ID, etc.

The user can type in some filters, such as part of the last name or accession number, or do a wild card query.

Sequoia can serve to itself as a virtual RIS if the scheduled study list is downloaded and saved before the system is unhooked from the network and made portable.

#### **3.2.5. DICOM Modality Performed Procedure Step AE**

DICOM Modality Performed Procedure Step AE is embedded in the Sequoia Begin page (or demographic page) application. It supports the N-Create and N-Set DIMSE Service Elements for the MPPS-SOP in the role of the SCU.

This AE uses DICOM Performed Procedure Step SCU to inform a Hospital Information System to indicate the status of a particular step. The Sequoia system software outputs event transactions to signal the start of a study (i.e. an image is captured.) or the end of the study (i.e.). The communicated information could be utilized by the HIS/RIS for managing the Modality Worklist. When a study is started, the N-CREATE DIMSE Service is used to construct the MPPS-SOP. The acquisition unit will not interact with the MPPS-SOP again until the study is ended. Then the study is ended, the Acquisition Unit will use the N-SET DIMSE service to set the values contained in the MPPS-SOP. During the interaction with the MPPS SCP, the value of the “Performed Procedure Step Status” (0004,0252) will be set to either “COMPLETED” or

“DISCONTINUED”. In addition, the contents of the “Performed Series Sequence” (0040,0340) will be updated so that all mandatory attributes are supplied.

### **3.2.6. DICOM Storage Commitment AE**

DICOM Storage Commitment AE is embedded in the successful completion of a study store to a DICOM Store SCP. It is dynamically negotiated when all images have been successfully stored to a server.

This AE uses DICOM Storage Commitment Push Model to inform the server when all stores for a study have been completed. The Storage Commitment SCU uses the N-ACTION primitive to request the SCP the safekeeping of a set of SOP instances (i.e. Ultrasound images) The Storage Commitment SCU also processes and N-EVENT-REPORT primitives that are received from the SCP in the event of the failure of the storage commitment.

### **3.2.7. DICOM MOD Media Interchange AE**

The DICOM MOD Media Interchange AE performs the following DICOM roles:

- File-set creator (FSC): it creates a DICOM MOD medium when the user copies studies/images to MO. A DICOM 3.0 conforming DICOMDIR file is created along with the directory structures and image files.
- File-set upator (FSU): it modifies the DICOMDIR file and image files when the user copies or deletes studies/images.
- File-set reader (FSR): it reads the DICOMDIR and makes a listing. It also reads and display images when the user chooses to do so.

Studies/images are copied to MOD if the user uses Study Util UI to select studies and copy them to MOD.

Studies/images are copied from MOD into the system if the user uses Study Util UI to select studies and copy them from MOD.

Images are read and displayed if the user uses Study Util UI to select a study for review. The DICOMDIR file is read and parsed by Study Util to generate the study listing.

Limitations:

- Only Acuson Aspen and Sequoia studies can be copied to and from MOD. A MOD can contain mixed Aspen and Sequoia studies.
- Only Acuson Aspen and Sequoia studies can be reviewed on Sequoia.
- The Aspen release version must be 3.0 or greater. The Sequoia release version must be 1.0 or greater.

The level of compatibility of Sequoia 4.0 and 5.x DICOM MOD with a non-Acuson DICOM 3.0 reader must be assessed by the maker of the reader.

### 3.3. Sequencing of Real World Activities

See the previous section.

## 4. Network Transfer Specifications

### 4.1. Supported SOP Classes

This implementation provides standard conformance to the following DICOM 3.0 SOP classes.

**TABLE 1. Verification SOP Class**

SOP Class Name	SOP Class UID	Role
Verification SOP Class	1.2.840.10008.1.1	SCU

**TABLE 2. Storage SOP Classes**

SOP Class Name	SOP Class UID	Role
Ultrasound Image	1.2.840.10008.5.1.4.1.1.6 (retired)	SCU
	1.2.840.10008.5.1.4.1.1.6.1	
Multi-frame Ultrasound Image	1.2.840.10008.5.1.4.1.1.3 (retired)	SCU
	1.2.840.10008.5.1.4.1.1.3.1	
Secondary Capture	1.2.840.10008.5.1.4.1.1.7	SCU

**TABLE 3. Print Management SOP Class**

SOP Class Name	SOP Class UID	Role
Basic Grayscale Print Management Meta	1.2.840.10008.5.1.1.9	SCU
Basic Color Print Management Meta	1.2.840.10008.5.1.1.18	SCU

TABLE 4. Modality Worklist Management SOP Class

SOP Class Name	SOP Class UID	Role
Modality Worklist Information Model FIND	1.2.840.10008.5.1.4.31	SCU

TABLE 5. Modality Worklist Management SOP Class

SOP Class Name	SOP Class UID	Role
Modality Performed Procedure Step	1.2.840.10008.3.1.2.3.3	SCU

TABLE 6. Storage Commitment Push SOP Class

SOP Class Name	SOP Class UID	Role
Storage Commitment Push	1.2.840.10008.1.20.1	SCU

## 4.2. Association Establishment Policies

### 4.2.1. General

The default PDU size is 32768 8-bit bytes unless a lower maximum is specified by the receiver during association negotiation, in which case the value negotiated will be used. Note that the peer must negotiate at least a maximum of 128 bytes.

### 4.2.2. Number of Associations

Multiple associations can be opened for the same or different types of transactions. The maximum number of simultaneous associations is 10.

### 4.2.3. Asynchronous Nature

This implementation does not support Asynchronous operation.

### 4.2.4. Implementation Identifying Information

This implementation will be identified by

- Implementation Class UID = 1.2.840.113680.15.1
- Implementation Version Name = DS<version>

#### 4.2.5. Calling and Called AE Titles

The SCU Calling AE Title is pre-configured at the installation time to be:

- SEQUOIA\_serial#

The user can change it if needed.

The Called AE Title is used by a SCP. This release does not contain a SCP.

#### 4.3. Association Initiation Policy

This implementation will initiate the association in the following manner.

- The Verification will open one association. It is closed at the end of the transaction.
- In Storage SCU, Sequoia opens one association per study in bulk storage mode. It varies in the in-progress mode.
- DICOM print will open one association per film session.

#### 4.3.1. Proposed Presentation Context

TABLE 7. Proposed Presentation Contexts for Sending Data/Request

Presentation Context (SCU)					
Abstract Syntax		Transfer Syntax		Role	Extended Negotiation
SOP Name	UID	Name list	UID list		
Tables 1~3	Tables 1~3	Implicit VR Little Endian	1.2.840.10008.1.2	SCU	None
Ultrasound Image	Table 2	RLE Loss-less Image Compression	1.2.840.10008.1.2.5	SCU	None
Multi-frame Ultrasound Image	Table 2	JPEG Baseline	1.2.840.10008.1.2.4.50	SCU	None

#### 4.3.2. SOP Specific Conformance of SCU

##### 4.3.2.1. Storage SOP Classes: Presentation Contexts

The Image Export AE is implemented in such a way that it negotiates with the peer AE the 5 possible presentation contexts as listed in Table 8 during the association.

It selects the SOP Class UID according to the scheme in Table 9. It composes one presentation context for exporting single frame images and one for multi-frame ones based on the selected SOP Class UID and Table 8.

**TABLE 8. Storage SCU SOP Class UID Selection Scheme**

<b>Image Type</b>	<b>Selection order: SOP Class UID</b>
Single Frame Ultrasound Image	1.2.840.10008.5.1.4.1.1.6.1 (new) 1.2.840.10008.5.1.4.1.1.6 (retired) 1.2.840.10008.5.1.4.1.1.7 (Secondary Capture)
Multi-frame Ultrasound Image	1.2.840.10008.5.1.4.1.1.3.1 (new) 1.2.840.10008.5.1.4.1.1.3 (retired)

**TABLE 9. Storage SCU Presentation Context Selection Scheme**

<b>SOP Class UID</b>	<b>Selection order: Transfer Syntax UID</b>
1.2.840.10008.5.1.4.1.1.6.1	1.2.840.10008.1.2.5 (RLE) 1.2.840.10008.1.2 (DICOM default)
1.2.840.10008.5.1.4.1.1.6	1.2.840.10008.1.2.5 (RLE) 1.2.840.10008.1.2 (DICOM default)
1.2.840.10008.5.1.4.1.1.3.1	1.2.840.10008.1.2.4.50 (JPEG Baseline) 1.2.840.10008.1.2 (DICOM default)
1.2.840.10008.5.1.4.1.1.3	1.2.840.10008.1.2.4.50 (JPEG Baseline) 1.2.840.10008.1.2 (DICOM default)
1.2.840.10008.5.1.4.1.1.7	1.2.840.10008.1.2 (DICOM default)

Sequoia sends SOP class UID and transfer syntax UID pairs to negotiate for the supported presentation contexts, i.e.,

SOP class UID 1 and Transfer Syntax UID 1

SOP class UID 1 and Transfer Syntax UID 2

SOP class UID 2 and Transfer Syntax UID 1

...

This may pose problems to servers that can only recognize the following method of grouping:

SOP class UID 1 and Transfer Syntax UID 1, Transfer Syntax UID 2

SOP class UID 2 and Transfer Syntax UID 1, ...

#### 4.3.2.2. Storage SOP Classes: Photometric Interpretation

Photometric Interpretation, i.e., color mode of the pixel image data, is not a negotiable parameter in DICOM 3.0.

This implementation exports color images in RGB mode and grayscale images in monochrome 2 if the peer AE only accepts uncompressed Implicit VR Little Endian transfer syntax. Images will be exported in a YBR color mode if either RLE or JPEG transfer syntax is used (see Table 7.)

TABLE 10. Photometric Interpretation of Exported Images

Ultrasound image SOP Class UID	Transfer Syntax and UID	Image Content	Photometric Inter- pretation
Single-frame: 1.2.840.10008.5.1.4.1.1.6.1 1.2.840.10008.5.1.4.1.1.6	Implicit VR Little Endian 1.2.840.10008.1.2	B/W	MONOCHROME2
Multi-frame: 1.2.840.10008.5.1.4.1.1.3.1 1.2.840.10008.5.1.4.1.1.3		Color	RGB
Single-frame: 1.2.840.10008.5.1.4.1.1.6.1	RLE Lossless Image Compression 1.2.840.10008.1.2.5	B/W or Color	YBR_FULL
Multi-frame: 1.2.840.10008.5.1.4.1.1.3.1	JPEG Baseline 1.2.840.10008.1.2.4.50	B/W or Color	YBR_FULL_422

#### 4.3.2.3. Storage SOP Classes: DICOM IOD Specification

This implementation uses DICOM 3.0 Part 3 and Supplement 5 as the DICOM Image IOD specification.

All the Type 1 and 2 elements specified in the DICOM 3.0 standard are encoded and exported. Some Type 3, 1C and 2C elements are also exported.

Private elements are also exported if the Storage SCP has been configured in the Sequoia machine to accept the private elements.

#### 4.3.2.4. Print SOP Class

The Sequoia DICOM configuration tool allows the user to configure the following printer parameters. The actual allowable values should be determined by reading the DICOM 3.0 Conformance Statement of the printer.

TABLE 11. User Configurable Print Parameters

Parameter	Tag	Editable Values
Medium Type	(2000, 0030)	PAPER   <b>BLUE FILM</b>   CLEAR FILM
Display Format	(2010, 0010)	STANDARD\1,1   STANDARD\1,2   STANDARD\2,2   <b>STANDARD\2,3</b>   STANDARD\3,2   STANDARD\3,3   STANDARD\4,4   STANDARD\4,5   STANDARD\5,6
Film Size ID	(2010, 0050)	<b>8INX10IN</b>   14INX17IN   10INX12IN   10INX14IN   11INX14IN   14INX14IN   24CMX24CM   24CMX30CM
Photometric Interpretation	(0028, 0004)	RGB (Colored)   <b>MONOCHROME2</b> (B/W)

Except the color mode, i.e., Photometric Interpretation, none of these parameters are negotiable by the DICOM 3.0 standard. Images will not be printed, for instance, if the user chooses a Display Format that the printer does not support.

Sequoia will automatically re-negotiate for grayscale printing if the color mode is not supported.

4.4. **Modality Worklist SOP Class Filtering and Requested Elements**

TABLE 12. **Filtering Query Elements**

<b>Description/Module</b>	<b>Tag</b>	<b>Value Range</b>
Scheduled Procedure Step Sequence	(0040, 0100)	
>Scheduled Procedure Step Start Date	(0040, 0002)	Today   Tomorrow   3 days   1 week   All <sup>a</sup>
>Scheduled Procedure Step Start Time	(0040, 0003)	0-235900
>Modality	(0008, 0060)	US   null
>Scheduled Procedure Step Description <sup>b</sup>	(0040, 0007)	see footnote
>Scheduled station AE title	(0040, 0001)	
Accession Number	(0008, 0050)	
Patient's Name	(0010, 0010)	
Patient's ID	(0010, 0020)	

- a. The date/range is internally in DICOM format, e.g., 19980510.
- b. Scheduled Procedure Step Description (0040, 0007) is "Study Type" in Sequoia Begin page. Sequoia ships with a list of study types. The site can customize it so that RIS and Ultrasound platform have the same list.

TABLE 13. **Request to Return Elements**

<b>Description/Module</b>	<b>Tag</b>
<b>Scheduled Procedure Step</b>	
Scheduled Procedure Step Sequence	(0040, 0100)
>Scheduled Station AE title	(0040, 0001)
>Scheduled Procedure Step Start Date	(0040, 0002)
>Scheduled Procedure Step Start Time	(0040, 0003)
>Modality	(0008, 0060)
>Scheduled Performing Physician's Name	(0040, 0006)
>Scheduled Procedure Step Description	(0040, 0007)
>Scheduled Station Name	(0040, 0010)
>Scheduled Procedure Step ID	(0040, 0009)
>Comments on the Scheduled Procedure Step	(0040, 0400)

TABLE 13. Request to Return Elements

Description/Module	Tag
<b>Requested Procedure</b>	
Requested Procedure ID	(0040, 1001)
Requested Procedure Description	(0032, 1060)
<b>Image Service Request</b>	
Accession Number	(0008, 0050)
Referring Physician's Name	(0008, 0090)
<b>Patient Identification</b>	
Patient's Name	(0010, 0010)
Patient's ID	(0010, 0020)
Patient Other ID	(0010, 1000)
Patient Comments	(0010,4000)
<b>Patient Demographic</b>	
Patient's Birth Date	(0010, 0030)
Patient Sex	(0010, 0040)
Patient Size	(0010, 1020)
Patient Weight	(0010, 1030)
Patient Last Menstrual Date	(0010,21d0)

4.5. Storage Commitment

TABLE 14. N-ACTION Request

Description/Module	Tag	Value Description
Transaction UID	(0008,1195)	Valid UID
Referenced SOP Sequence	(0008,1199)	
>Referenced SOP Class UID	(0008,1150)	Class UID of each object stored
>Referenced SOP Instance UID	(0008, 1155)	UID for each Primary Image

#### 4.6. Modality Performed Procedure Step

TABLE 15. N-CREATE Service Request (Study Start)

Description/Module	Tag	Value Description
<b>Scheduled Procedure Step</b>		
Scheduled Step Attribute Sequence	(0040,0270)	
>Study Instance UID	(0020, 000D)	a
>Reference Study Sequence	(0008, 1110)	null
>Accession Number	(0008, 0050)	a
>Requested Procedure ID	(0040, 1001)	a
>Requested Procedure Description	(0040, 0001)	a
>Scheduled Procedure Step ID	(0040, 0009)	a
>Scheduled Procedure Description	(0040, 0007)	a
>Scheduled Action Item Code Sequence	(0040, 0008)	null
Patient's Name	(0010, 0010)	
Patient's ID	(0010, 0020)	
Patient's Birth Date	(0010, 0030)	
Patient Sex	(0010, 0040)	
Referenced Patient Sequence	(0008,1120)	null
<b>Performed Procedure Step Information</b>		
Performed Procedure Step ID	(0040,0253)	
Performed Station AE Title	(0040,0241)	
Performed Station Name	(0040,0242)	
Performed Location	(0040,0243)	null
Performed Procedure Step Start Date	(0040,0244)	
Performed Procedure Step Start Time	(0040,0245)	
Performed Procedure Step Status	(0040,0254)	"INPROGRESS"
Performed Procedure Step Description	(0040,0254)	
Performed Procedure Type Description	(0040,0255)	null
Procedure Code Sequence	(0008,1032)	null
Performed Procedure Step End Date	(0040,0250)	null
Performed Procedure Step End Time	(0040,0251)	null
<b>Image Acquisition Results</b>		
Modality	(0008,0060)	
Study ID	(0020,0010)	

**TABLE 15. N-CREATE Service Request (Study Start)**

<b>Description/Module</b>	<b>Tag</b>	<b>Value Description</b>
Performed Action Item Code Sequence	(0040,0260)	null
Performed Series Sequence	(0040,0340)	null

a. Uses relevant attributes from the Modality Worklist when available.

**TABLE 16. N-Set Service Request (Study End)**

<b>Description/Module</b>	<b>Tag</b>	<b>Value Description</b>
<b>Performed Procedure Step Information</b>		
Performed Procedure Step Status	(0040,0254)	“COMPLETED” or “DISCONTINUED”
Performed Procedure Step End Date	(0040,0250)	
Performed Procedure Step End Time	(0040,0251)	
<b>Image Acquisition Results</b>		
Performed Series Sequence	(0040,0340)	
>Performing Physician’s Name	(0008,1050)	null
>Protocol Name	(0018,1030)	“NONE”
>Operator’s Name	(0008,1070)	
>Series Instance UID	(0020,000E)	
>Series Description	(0008,103E)	
>Retrieve AE Title	(0008,0054)	null
>Referenced Image Sequence	(0008,1140)	One for each clip/image
>>Referenced SOP Class UID	(0008,1150)	
>>Referenced SOP Instance UID	(0008,1155)	
>Referenced Stand-alone SOP Sequence	(0040,0220)	One for each SR Object
>>Referenced SOP Class UID	(0008,1150)	
>>Referenced SOP Instance UID	(0008,1155)	

**4.7. Association Acceptance Policy**

This implementation does not accept an association request.

**4.8. Communication Profile**

This implementation supports TCP/IP Protocol stack.

OSI stack is not supported.

DICOM 50-pin physical connection is not supported.

This implementation is indifferent to the underlying physical medium. It only requires TCP/IP in the Transport and Network layers.

## 5. Removable Media Interchange Specifications

This implementation supports two 3.5” DICOM MOD removable media. It conforms to DICOM 3.0 Part 10, 11 and 12.

### 5.1. Supported SOP Classes

This implementation provides standard conformance to the following DICOM 3.0 SOP classes.

TABLE 17. Media Storage SOP Classes

SOP Class Name	SOP Class UID	Roles
Ultrasound Image	1.2.840.10008.5.1.4.1.1.6.1	FSC
Multi-frame Ultrasound Image	1.2.840.10008.5.1.4.1.1.3.1	FSU FSR
DICOM Media Storage Directory	1.2.840.10008.1.3.10	

### 5.1.1. Proposed Transfer Syntaxes

TABLE 18. Proposed Transfer Syntaxes for Media Interchange

Abstract Syntax		Transfer Syntax	
SOP Name	UID	Name list	UID list
Ultrasound Image	Table 9	RLE Loss-less Image Compression	1.2.840.10008.1.2.5
Multi-frame Ultrasound Image	Table 9	JPEG Base-line	1.2.840.10008.1.2.4.50
DICOM Media Storage Directory	Table 9	Explicit VR Little Endian	1.2.840.10008.1.2.1

### 5.1.2. Physical Storage Media and Media Formats

The physical storage media are 90mm (3.5") 128MB and 230MB magneto-optical disks.

The disks are formatted in PC (DOS) file system format.

## 6. Data Identification Information

Patient and image data originated from an Sequoia system can be identified by the Study Instance UID, Series Instance UID and SOP Instance UID, i.e., DICOM elements (0020, 000D), (0020, 000E) and (0008, 0018) in the IOD.

- Sequoia UID root is 1.2.840.113680.1.103, where  
1.2.840.113680 is the ANSI registered Acuson UID root.
- The Study Instance UID is composed using the following convention:  
1.2.840.113680.1.103.n.s.t  
where  
n = serial number of the Sequoia machine  
s = the UNIX epoch based time since a base time in seconds  
t = microsecond within the second of current UNIX epoch-base time
- The Series Instance UID is composed of the Study Instance UID and the series number:  
1.2.840.113680.1.103.n.s.t.r  
where  
r = 1 for full-screen static and dynamic and quarter-size static images  
r = 2 for quarter-screen dynamic images
- The SOP Instance UID is composed of the Series Instance UID and the image number:  
1.2.840.113680.1.103.n.s.t.r.f  
where  
f = image number

## 7. Extensions, Specializations and Privatizations

The private elements and files listed in this section are primarily intended for Acuson internal use.

## 7.1. Private DICOM Elements

The Acuson private group (7FDF, xxxx) is used in DICOM image IOD files.

TABLE 19. Acuson Private DICOM Elements

Element Name	Tag	VR	VM	Description
Private Creator	7FDF, 0010	LO	1	To reserve element tags 1000-10FF, value set to ACUSON: 1.2.840.11386.0.1.0
Lossy Compression Ratio	7FDF, 1000	IS	1	JPEG compression ratio
Image Format	7FDF, 1001	US	1	01H = STATIC 05H = FULL SIZE CLIP 06H = 1/4 SIZE CLIP 07H = 1/4 SIZE ROI CLIP
Acuson Region Type	7FDF, 1002	US	1	01H = PATIENT IDENTIFIER 02H = USEFUL DISPLAY 03H = ACQ IMAGE NUMBER
Acuson Image Apex X	7FDF, 100B	UL	1	X coordinate of pair defining location of a virtual image apex
Acuson Image Apex Y	7FDF, 100C	UL	1	Y coordinate of pair defining location of a virtual image apex
B-Color-On Flag	7FDF,100D	IS	1	0 = B-COLOR absent 1 = B-COLOR present
Data Padding	7FDF, FE00	OB	1	It is a padding element before pixel data to allow the DICOM header elements to grow and shrink.

## 7.2. Private Files

There are a few Acuson private files in DICOM MOD study directories. These files are in a semi-proprietary “Explicit VR Big Endian” file format.

1. DBRECORD file: patient demographic and study information that apply to all the images in the study.
2. ACQ\_SET file: acquisition protocol and acquired image set information.
3. DSP\_SET file: image set selected for display.

Many private DICOM elements are used in these files. They are not documented here because they are only used internally by Acuson software during image acquisition.

A non-Acuson DICOM reader should not attempt to parse these private files. All the DICOM supported data are already in the DICOMDIR and DICOM image files.

## **8. Configuration**

The Sequoia Service User Interface database maintains configuration parameters of remote and local DICOM Application Entities. The parameters include:

- AE identification, i.e., a descriptive name
- Calling AE Title (for Sequoia DICOM SCU)
- Called AE Title (for a remote SCP)
- TCP port number (for a remote SCP)
- IP address or host name (for a remote host where the remote SCP resides)
- DICOM print parameters for a DICOM print SCP entry
- Some specialized information

This configuration database can be copied to other Sequoia machines on the network via a MO disk.

The local DICOM applications read information from this database. DICOM configuration tool is the only application that can modify this database.

## **9. Support of Extended Character Sets**

The following character set is supported:

ISO-IR 100 Latin Alphabet No. 1

## **10. Comments**

Acuson is an active member on the ACR-NEMA DICOM standards committee. Acuson is striving to make DICOM a better standard for our customers.



**Approval for Sequoia 3.0 DICOM Conformance Statement**

\_\_\_\_\_  
Engineering

\_\_\_\_\_  
Date

\_\_\_\_\_  
General Imaging Business Unit

\_\_\_\_\_  
Date

\_\_\_\_\_  
Cardiology Business Unit

\_\_\_\_\_  
Date

\_\_\_\_\_  
International Business Unit

\_\_\_\_\_  
Date

\_\_\_\_\_  
Regulatory

\_\_\_\_\_  
Date

\_\_\_\_\_  
Legal

\_\_\_\_\_  
Date

\_\_\_\_\_  
DICOM Czar

\_\_\_\_\_  
Date