

The information provided herein is proprietary work, produced by Siemens Medical Systems, Inc., Ultrasound Group. Any reproduction, disclosure, or use of this material in whole or in part not authorized in writing is prohibited and is in violation of the rights of Siemens Medical Systems, Inc.

Siemens Medical Systems, Inc. Ultrasound Group
**SONOLINE Elegra Product Platform
DICOM Conformance Statement**

4911058-L0958

Revision 05

Revision Data

Description	Printed Name
Updated contents to reflect SONOLINE Elegra 5.0 SW release	D. Grob

1	PURPOSE.....	4
1.1	Scope	4
2	IMPLEMENTATION MODEL.....	4
2.1	Application Data Flow Diagram.....	4
2.1.1	Verification.....	5
2.1.2	Store to Disk.....	5
2.1.3	Copy To.....	5
2.1.4	Print 1 and Print 2	6
2.1.5	Print To.....	6
2.1.6	New Patient.....	6
2.1.7	Modality Performed Procedure Step.....	8
2.1.8	Storage Commitment	8
2.2	AE Functional Definition	10
2.2.1	Verification Real-World Activities:	10
2.2.2	Store Real-World Activities	10
2.2.3	Print Real-World Activities.....	10
2.2.4	Worklist Real-World Activity	10
2.2.5	Modality Performed Procedure Step Real-World Activity	10
2.2.6	Storage Commitment – Push Model Real World Activity.....	10
2.3	Sequencing of Real-World Activities	10
3	AE SPECIFICATIONS	11
3.1	SONOLINE Elegra AE Specification.....	11
3.1.1	Association Establishment Policies.....	11
3.1.1.1	General	11
3.1.1.2	Number of Associations.....	12
3.1.1.3	Asynchronous Nature	12
3.1.1.4	Implementation Identifying Information.....	12
3.1.2	Association Initiation by Real-World Activities	12
3.1.2.1	Real World Activity – Verification.....	12
3.1.2.2	Real World Activity – Store	13
3.1.2.3	Real World Activity - Print	19
3.1.2.4	Real World Activity - Worklist.....	24
3.1.2.5	Real World Activity - Modality Performed Procedure Step.....	27
3.1.2.6	Real World Activity – Storage Commitment	34
4	COMMUNICATION PROFILES	36
4.1	TCP/IP Stack Supported.....	36
4.1.1	Physical Media Supported	36

5 EXTENSIONS/SPECIALIZATIONS/PRIVATIZATIONS36

5.1 Standard Extended/Specialized/Private Syntaxes36

5.2 Private Transfer Syntaxes.....36

6 CONFIGURATION.....37

6.1 Basic System Configuration.....37

6.1.1 Organization Name37

6.1.2 Department Name37

6.1.3 System Location.....37

6.2 DICOM Network Configuration37

6.2.1 Local.....38

6.2.2 Remote.....38

6.3 DICOM Store Configuration38

6.4 DICOM Storage Commitment38

6.5 DICOM Worklist Configuration38

6.6 DICOM Performed Procedure Step Configuration39

6.7 DICOM Print Configuration39

6.8 Exam Types Configuration40

6.9 External Equipment Configuration41

7 SUPPORT OF EXTENDED CHARACTER SETS41

8 REFERENCES.....41

9 GLOSSARY41

1 Purpose

This document describes the conformance to the ACR-NEMA DICOM 3.0 Standard by the SONOLINE[®] Elegra ultrasound imaging system software version 5.0 from Siemens Medical Systems, Inc. Ultrasound Group. It shall establish the conformance specifications for this system only, and does not apply to other products offered by Siemens Medical Systems, or its affiliates.

The SONOLINE Elegra system is a device that generates ultrasound images and other data that can be sent using DICOM standard protocols and definitions to other DICOM compliant devices including any DICOM compliant devices that support SOP classes as defined in table 3.1-1 in this document.

1.1 Scope

The DICOM standard provides a well-defined set of structures and protocols that allow inter-operability of a wide variety of medical imaging devices.

When configured with the DICOM option, the SONOLINE Elegra system provides support for essential services related to ultrasound scanning and connectivity to DICOM compliant devices. SONOLINE Elegra system products will not support all features supported by the DICOM standard. This document clearly states the DICOM services and data classes that are supported by the applications included with the SONOLINE Elegra system. The intent of this document is to allow users and other vendors who also conform to the DICOM standard to exchange information within the specific context of those elements of the DICOM standard that SONOLINE Elegra system supports.

This document is written with respect to the adopted portions of the DICOM standard, Revision 3. The following sections of this document follow the outline specified in the DICOM Standard NEMA publication PS3.2.¹

2 Implementation Model

SONOLINE Elegra system users can store images and other data directly on the system hard disk. Images can be exported to a DICOM archive server or workstation on a network. The user is capable of querying a DICOM Worklist server for a list of scheduled patient procedures, as well as supporting a Modality Performed Procedure Server. Storage Commitment is provided as “push model” only. In the following sections, SONOLINE Elegra system real world activities are indicated by “Real World Activity” name while “ELEGRA AE” indicates the invoked Application Entity. Similarly, the activities associated with service providers are indicated as “Real World Service Activity”.

2.1 Application Data Flow Diagram

Figure 2.1 illustrates the SONOLINE Elegra Application Entity (AE) which is shown in the box. Relationships between user invoked activities (in the circles at the left of the AE) and the associated real-world activities provided by DICOM service providers (in the circles on the right side of the diagram) are shown. The user selects “**New Patient**” at the start of each new patient examination.

Selecting either “**End Exam**” or “**New Patient**” ends the previous exam. When an “End Exam” message is presented to the SONOLINE Elegra AE all associations to open DICOM open devices are closed.

¹ Second part of the DICOM standard: NEMA Standards Publication PS 3.2-1998, Digital Imaging and Communications in Medicine (DICOM), Part 2: Conformance

2.1.1 Verification

Verification is a part of the DICOM configuration tool located on the 'DICOM' page of the System Presets. Verification can be used to send a DICOM verification request to a remote Application Entity (AE) and will listen for a response. Verification can also be configured to be automatically invoked prior to any of the other SONOLINE Elegra 'Real World Activities' (RWA).

When used as a diagnostic tool, Verification will return the following messages to the user:

1. Echo to "Host" Successful
2. Echo to "Host" Unsuccessful

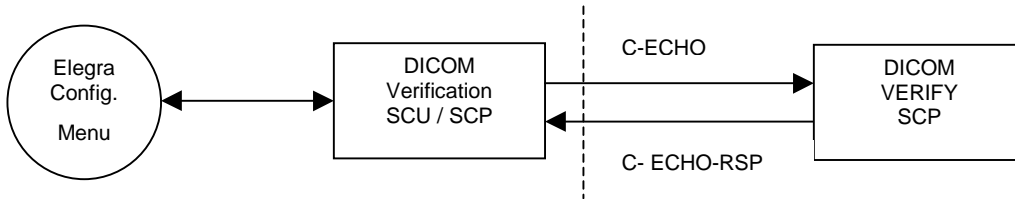

Figure 2.1.1-1 Verification Model

2.1.2 Store to Disk

To invoke the DICOM Store, the user selects "Store to Disk" (a SONOLINE Elegra system real world activity) during a patient exam, causing the image currently displayed on the Ultrasound screen to be captured and sent to a DICOM device on the network. The destination device (attached to the "Store to Disk" key) is selected through System Presets by choosing from a list of available DICOM devices on the network.

Captured images can be transmitted to the selected STORE destination immediately after capture or all images for an exam can be held and transmitted at the end of exam. This can be configured on a per device basis through the User Presets.

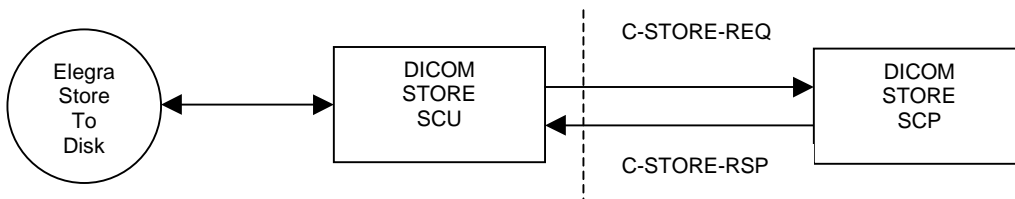

Figure 2.1.2-1 Store Model

2.1.3 Copy To

The user can also select "Copy To", another SONOLINE Elegra Real World Activity, to copy one or more selected exams or individual images from the hard disk drive of the SONOLINE Elegra system to a pre-configured DICOM server. "Copy To" is available through the Manage Records function.

2.1.4 Print 1 and Print 2

The user may either select the desired network grayscale or color printer server using the User Presets function. In Presets, a desired printer is assigned to either the "PRINT 1" or "PRINT 2" hard key. The Presets function is also used to define the configuration of the DICOM Print Service Provider. Image format on the hardcopy is determined from the format described in the Presets function.

To invoke the Print "REAL WORLD ACTIVITY", the user selects the "PRINT 1" or "PRINT 2" hard key. Print images are sent immediately after the hard key is pressed.

2.1.5 Print To

After an image exam is complete, the user has the ability to Print images stored on the hard drive using the Manage Records function. Invoking the "Print To" Real World activity invokes the DICOM Print activity for selected exams or individual images. "Print To" is available through the Manage Records function. The SONOLINE Elegra system is capable of grayscale and color images.

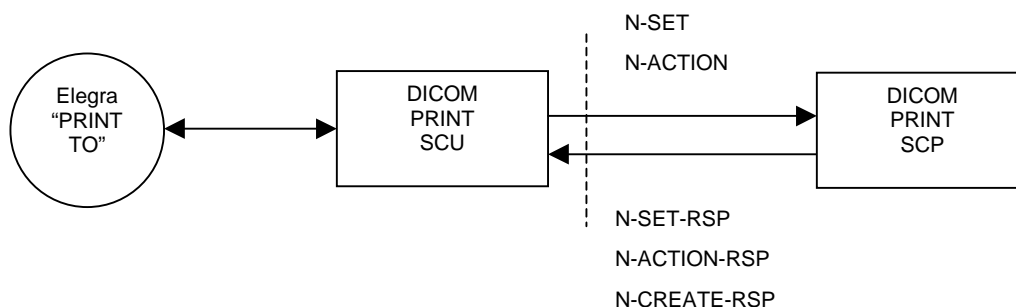

Figure 2.1.5-1 Print Model

2.1.6 New Patient

Patient registration can be automated by using the 'Worklist' Real World Activity. Depressing the 'New Patient' key on the keyboard initiates the patient data registration process. Pressing the 'Worklist' option on the patient data display screen invokes the Worklist query menu.

Initiating the 'Search' button will attempt to find all matching patients using the information from the Worklist Query menu. Patient name fields that are partially filled or empty will be treated as though an implicit wildcard was appended at the end of the field. ID and Accession number will be exact match only. If only one matching patient is found in the query, the patient data field will be immediately populated using the returned information. If no matches are found, a message will be presented to the operator indicating so. If more than one matching patient is found, a pick list of patient exams will be presented to the user to select from. Each of the fields will be sortable in ascending and descending order. The list will be limited to 75 entries. If more than 75 matching records are found in the query, the user will be prompted to limit the search by entering additional search criteria. The search list criteria will contain:

- Patient Name
- Patient ID
- Accession Number
- Procedure Start Date
- Requested Procedure ID
- Exam Type
- Scope-This Elegra

The user will have the option to select a patient exam, or cancel the operation. Selection of a patient from the list will cause all demographic information for that patient to be loaded in to the patient data fields.

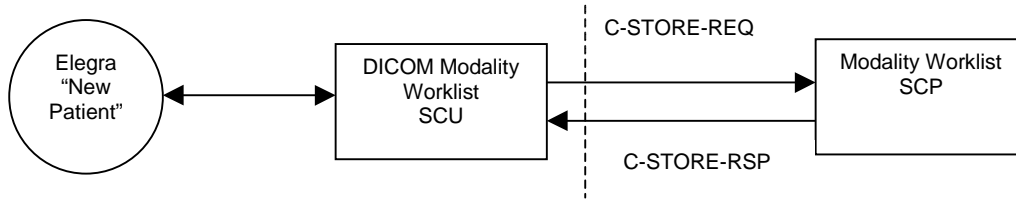

Figure 2.1.6-1 Modality Worklist Model

The following data fields will be populated on the patient data screen:

Attribute Name	Tag
Patients Full Name	(0010,0010)
Patient ID	(0010,0020)
Accession Number	(0008,0050)
Date of Birth	(0010,0030)
Gender	(0010,0040)
Weight	(0010,1030)
Height	(0010,1020)
Physician	(0008,0090)
Exam Type	(0008,1030)
Indications	(0008,1080)
Scheduled Action Item Code Sequence	(0040,0008)

Once a Worklist query is initiated a "Querying DICOM Worklist Server" dialog will be presented to the user. The user will only have one option "CANCEL" which will abort the query operation.

2.1.7 Modality Performed Procedure Step

The SONOLINE Elegra system supports the display of Modality Performed Procedure Step (MPPS) orders when the patient registration process utilizes the 'Worklist' Real World Activity. Procedure steps are presented to the operator after successful query of a server that supports the MPPS option. A detail window allows the operator access to individual or multiple scheduled procedure steps. Pressing the 'Edit Procedures' push button on the Patient Data Screen actualizes the detail window.

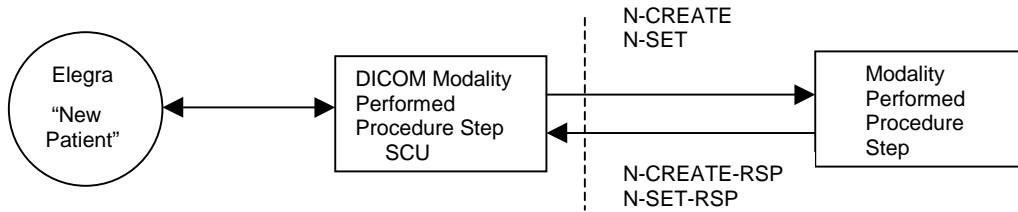

Figure 2.1.7-1 MPPS Model

2.1.8 Storage Commitment

The user can exercise the Storage Commitment option by selecting the Storage Commitment option from the System Pre-sets menu. The SONOLINE Elegra system requests commitment of images and upon successful acknowledgment from the Storage server marks images on the system hard drive as 'eligible for deletion'.

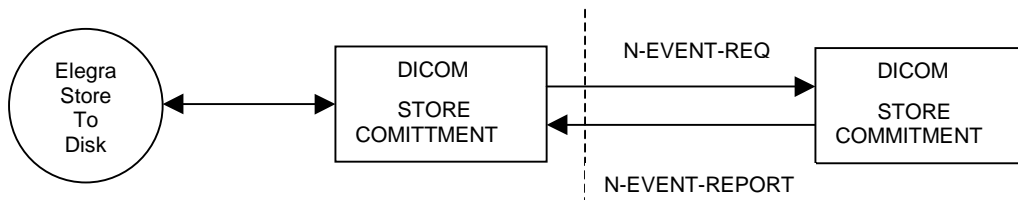
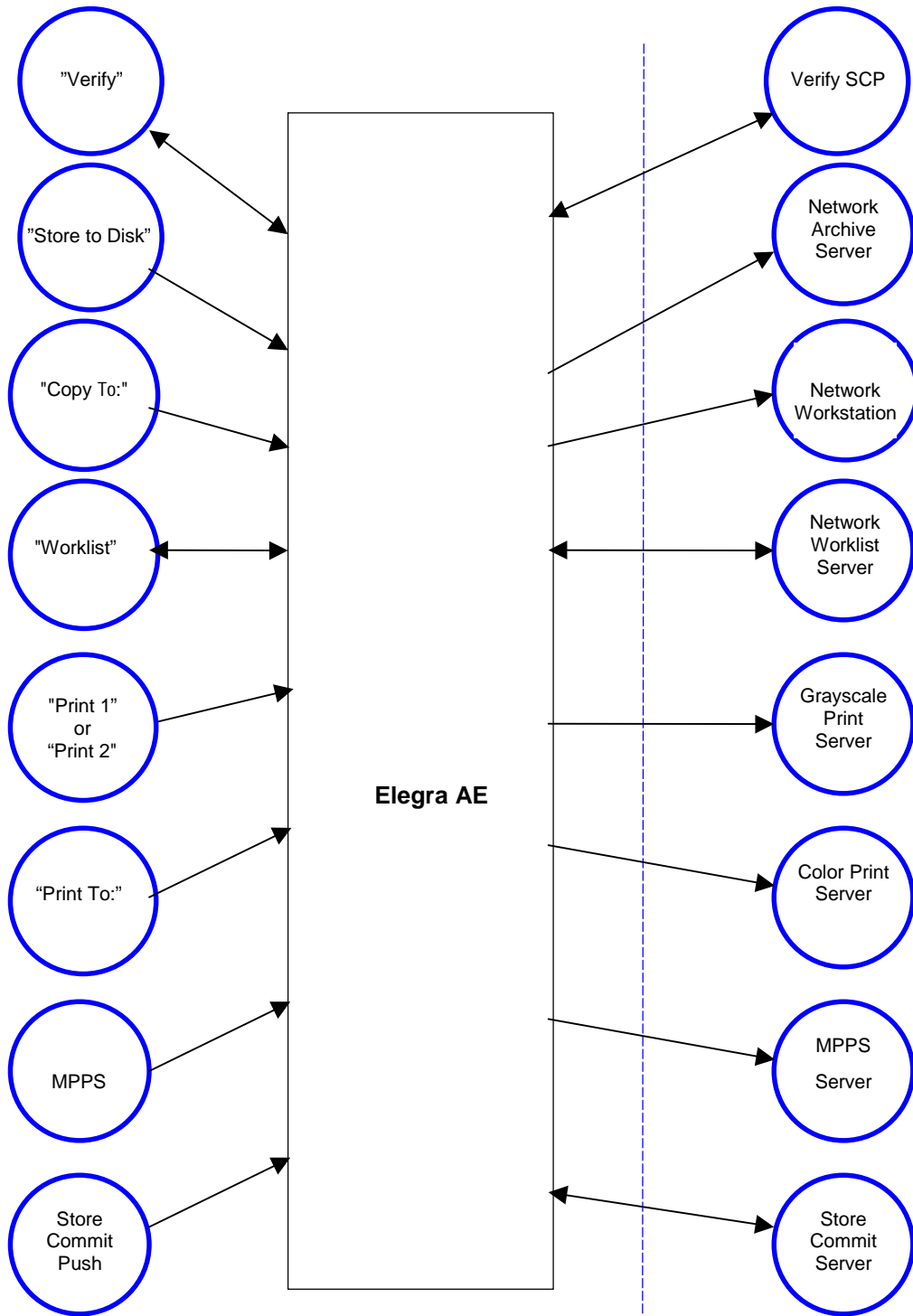

Figure 2.1.8-1 Storage Commitment Model

SONOLINE Elegra Local Processes

Remote Processes



**Figure 2.1.8-2 - Implementation Model
DICOM Standard Interface**

2.2 AE Functional Definition

2.2.1 Verification Real-World Activities:

The SONOLINE Elegra application entity performs Verification Service Class as SCU and SCP thus allowing the operator to verify the ability of an application on a remote node to receive DICOM messages. (C-ECHO DIMSE) The user can toggle Verification on or off for any of the other SONOLINE Elegra Real World Activities.

2.2.2 Store Real-World Activities

The SONOLINE Elegra application entity performs all of the functions to transmit ultrasound image and associated data to network servers and/or workstations. The SONOLINE Elegra AE supports the Ultrasound Image Storage SOP class as an SCU. The AE initiates separate associations to the store servers, verifying their on-line status when the user selects “Store to Disk” or “Copy To”.

2.2.3 Print Real-World Activities

The SONOLINE Elegra AE provides all aspects of the Print Management SCU. The AE initiates separate associations to the print servers, verifying their on-line status when the user selects “Print 1”, “Print 2” or “Print To”. The SONOLINE Elegra AE accommodates both grayscale and color print servers.

2.2.4 Worklist Real-World Activity

The SONOLINE Elegra AE supports the DICOM Basic Worklist Management Service as an SCU. The AE initiates an association to the active Worklist server when a Worklist query is selected (via the “Worklist” button). The association is closed upon the completion of each query. A maximum of 75 matching results is accepted, at which point, the SONOLINE Elegra AE issues a C-FIND-CANCEL request.

2.2.5 Modality Performed Procedure Step Real-World Activity

The SONOLINE Elegra AE supports Modality Performed Procedure Step (MPPS) in the role of SCU. The SONOLINE Elegra system is capable of displaying scheduled procedure steps via the User Interface (UI) for Modality Performed Procedure Step. The operator can select a single PPS or combine multiple PPS into one MPPS step. The operator can notify the MPPS server that a MPPS is ‘In Progress’, ‘Discontinued’ or ‘Completed’. The operator is also capable of creating ‘Unscheduled’ PPS(s) with a description from the UI.

2.2.6 Storage Commitment – Push Model Real World Activity

The SONOLINE Elegra AE supports Storage Commitment SOP class to inform servers when all the store operations for a study have been completed. The Storage Commitment SCU uses the N-ACTION primitive to request safekeeping of a set of SOP Instances (Ultrasound Images). The Storage Commitment SCU also processes the N-EVENT-REPORT primitives that are received from the SCP indicating ‘successful’ or ‘non-successful’ commitment status. The N-EVENT-REPORT information is used to mark ‘eligible’ images for deletion from the hard drive.

2.3 Sequencing of Real-World Activities

In order for any of the remote processes to be able to provide the Real World Activity SCP services which the SONOLINE Elegra system, an SCU, has requested, the appropriate associations must have been previously opened. This initiation occurs with the “Store to Disk” and “Copy To:” for image store operations, “Print 1”, “Print 2” and “Print To:” for image printing operations “Worklist” for Worklist query operations

3 AE Specifications

The following specifications apply to the AE as depicted in Figure 2.1.

3.1 SONOLINE Elegra AE Specification

The SONOLINE Elegra AE provides conformance to the following DICOM Service SOP Classes as an SCU:

Table 3.1-1 Supported SOP Classes

Service SOP Class Name	SOP Class UID
Ultrasound Image Storage	1.2.840.10008.5.1.4.1.1.6.1
Ultrasound Image Storage (Retired)	1.2.840.10008.5.1.4.1.1.6
Secondary Capture Image Storage	1.2.840.10008.5.1.4.1.1.7
Verification	1.2.840.10008.1.1
Basic Grayscale Print Management Meta SOP Class	1.2.840.10008.5.1.1.9
Basic Color Print Management Meta SOP Class	1.2.840.10008.5.1.1.18
Basic Film Session SOP Class	1.2.840.10008.5.1.1.1
Basic Film Box SOP Class	1.2.840.10008.5.1.1.2
Basic Grayscale Image Box SOP Class	1.2.840.10008.5.1.1.4
Basic Color Image Box SOP Class	1.2.840.10008.5.1.1.4.1
Printer SOP Class	1.2.840.10008.5.1.1.16
Modality Performed Procedure Step	1.2.840.10008.3.1.2.3.3
Modality Worklist Information Model - FIND	1.2.840.10008.5.1.4.31
Storage Commitment - Push Model	1.2.840.10008.1.20.1

3.1.1 Association Establishment Policies

3.1.1.1 General

The SONOLINE Elegra system uses TCP/IP. The Maximum Length PDU negotiation is included in all association establishment requests. The maximum length PDU offered for an association initiated by the SONOLINE Elegra system is:

- Maximum PDU Offered: 16k

3.1.1.2 Number of Associations

The SONOLINE Elegra application initiates one/several association(s) at a time, one for each transfer request being processed. Store requests are negotiated sequentially in the following order: New Ultrasound IOD, Retired Ultrasound IOD, and Secondary Capture.

- Store to Disk
- Print 1
- Print 2
- Copy To: or Print To:
- Worklist
- Modality Performed Procedure Step SOP Class
- Storage Commitment – Push Model SOP Class

3.1.1.3 Asynchronous Nature

All associations use the default synchronous mode of operation. Asynchronous Operations Window negotiations are not supported on the SONOLINE Elegra system.

3.1.1.4 Implementation Identifying Information

- Implementation Class UID: “1.3.12.2.1107.5.5.1” (See below).
- Implementation Version Name: “SMSUG-vQ5.0” (where vQ5.0 is the Software release version).

Siemens has provided registration for all Siemens Medical Systems Groups. This unique Class UID is defined as: “1.3.12.2.1107.5.5.product”

Where the interpretation is:

1. = International Standards Organization (ISO)

3. = International branch of ISO

12.2.1107.5. = Assigned to Siemens-UB MED

5. = Ultrasound Modality (SMS-UG)

Product =. 1= First SMS-UG product to support DICOM (e.g. SONOLINE ELEGRA)

3.1.2 Association Initiation by Real-World Activities

3.1.2.1 Real World Activity – Verification

The SONOLINE Elegra system is capable of supporting Verification service class as SCU and SCP. Verification can be initiated as a singular event from the Systems Pre-Sets menu to any configured SCP that supports Verification. Verification can also be automatic, when selected in addition to other SOP Classes supported. When selected in the DICOM configuration menu, Verification is invoked whenever the AE initiates an association to another AE for Store, Print, Worklist, Modality Performed Procedure Step and Storage Commitment.

3.1.2.1.1 Proposed Presentation Contexts – Verification

The SONOLINE Elegra system will propose Presentation contexts as shown in the following table:

Table 3.1.2.1.1-1 Verification Presentation Context Table

Abstract Syntax		Transfer Syntax		Role	Extended Negotiation
Name	UID	Name List	UID List		
Verification	1.2.840.10008.1.1	DICOM Explicit VR Little Endian	1.2.840.10008.1.2.1	SCU SCP	None
Verification	1.2.840.10008.1.1	Implicit VR Little Endian	1.2.840.10008.1.2	SCU SCP	None

3.1.2.2 Real World Activity – Store

The user selects “New Patient” at the start of each new patient examination. When images are transferred to a DICOM Store SCP, the system establishes an association between the SONOLINE Elegra AE and the identified DICOM device (i.e. Network Archive Server, Workstation Server)

The SONOLINE Elegra system can be configured to send images individually, as they are acquired during the exam (In Progress Review), or to send all images at the end of the exam. If the system is configured to send images during the exam, an association is opened when the first Store to Disk operation occurs. The association remains open for the entire exam and is closed when the user selects either “End Exam” or “New Patient”.

If the system is configured to send images at the End of Exam, an association is opened and all images acquired during the exam are transferred when the user selects either “End of Exam” or “New Patient”. After all images are transferred, the association is closed.

3.1.2.2.1 Associated Real World Activities

An association is established when the user initiates a “Copy To” operation from the Manage Records screen.

Individual images or entire exams can be transferred to the selected DICOM Store device. The association is opened when the first image of each exam is transferred and closed when the last image transfer is completed. An association is also opened after a network outage and images are queued to be stored or when the system is powered-on and images are queued to be stored. After all images have been stored, the association is closed.

3.1.2.2.2 Proposed Presentation Context

The following Presentation Context(s) is presented to the SCP in an A-Associate request for DIMSE C-STORE storage services. The storage services utilize C-STORE services, whose parameters are defined in PS 3.7 (Table 9.1-1).

The following Presentation Context applies to both “Store to Disk” and “Copy To:” Real World Activities.

Table 3.1.2.2-1 Store Presentation Context Table

Abstract Syntax		Transfer Syntax		Role	Extended Negotiation
Name	UID	Name List	UID List		
Ultrasound Image Storage	1.2.840.10008.5.1.4.1.1.6.1	DICOM Implicit VR Little Endian	1.2.840.10008.1.2	SCU	None
Ultrasound Image Storage	1.2.840.10008.5.1.4.1.1.6.1	DICOM Explicit VR Little Endian	1.2.840.10008.1.2.1	SCU	None
Ultrasound Image Storage (Retired)	1.2.840.10008.5.1.4.1.1.6	DICOM Implicit VR Little Endian	1.2.840.10008.1.2	SCU	None
Ultrasound Image Storage (Retired)	1.2.840.10008.5.1.4.1.1.6	DICOM Explicit VR Little Endian	1.2.840.10008.1.2.1	SCU	None
Secondary Capture Image Storage	1.2.840.10008.5.1.4.1.1.7	DICOM Implicit VR Little Endian	1.2.840.10008.1.2	SCU	None
Secondary Capture Image Storage	1.2.840.10008.5.1.4.1.1.7	DICOM Explicit VR Little Endian	1.2.840.10008.1.2.1	SCU	None

The SONOLINE Elegra system always acts as an SCU and is the client in a client-server model. The ultrasound system will negotiate associations in the following order: New US IOD, Retired US IOD, and Secondary Capture. **SOP Specific Conformance to Storage Service SOP Classes**

The Store REAL WORLD ACTIVITY provides standard extended conformance as an SCU for the following standard Storage Service Class SOP:

Table 3.1.2.2.1-1 Supported SOP Classes

Service SOP Class Name	SOP Class UID	Conformance Level
Ultrasound Image Storage	1.2.840.10008.5.1.4.1.1.6.1	Standard Extended
Ultrasound Image Storage (Retired)	1.2.840.10008.5.1.4.1.1.6	Standard Extended
Secondary Capture Image Storage	1.2.840.10008.5.1.4.1.1.7	Standard Extended

This is accomplished using the DIMSE C-STORE Service to whom the SCU issues a service request with a SOP instance that meets the requirements of the desired ultrasound IOD.

The following table denotes the attributes included in the Ultrasound Image Object as implemented on the SONOLINE Elegra system. Attributes not listed are not used.

Table 3.1.2.2.1-2 US Image IOD Attributes Used

Module	Attribute	Tag	Notes
Patient	Patient's Name	(0010,0010)	Elegra Patient Data Screen – Last Name, First & MI fields. Default is “Unknown”.
	Patient ID	(0010,0020)	Elegra Patient Data Screen – ID field. Default is today's date & time (i.e. 9804241022 = Apr. 24, 1998 – 10:22am).
	Patient's Birth Date	(0010,0030)	Elegra Patient Data Screen – DOB field. Default is a zero length attribute.
	Patient's Sex	(0010,0040)	Elegra Patient Data Screen – Gender field. M = male F = female. Default is a zero length attribute.
General Study	Study Instance UID	(0020,000D)	
	Study Date	(0008,0020)	Date the exam started.
	Study Time	(0008,0030)	Time the exam started.
	Referring Physician's Name	(0008,0090)	Elegra Patient Data Screen – Physician field.
	Study ID	(0020,0010)	Set to “1”.
	Accession Number	(0008,0050)	Elegra Patient Data Screen – Accession # field.
	Study Description	(0008,1030)	Elegra Patient Data Screen – Exam Type field (e.g. Liver, Abdomen, etc.). Default is “Unknown”.
Patient Study	Admitting Diagnoses Description	(0008,1080)	Elegra Patient Data Screen – Indications field.
	Patient's Size	(0010,1020)	Patient height in meters. Default is zero length attribute.
	Patient's Age	(0010,1010)	
	Patient's Weight	(0010,1030)	Patient weight in kg. Default is zero length attribute.

Table 3.1.2.2.1-2 US Image IOD Attributes Used (cont.)

Module	Attribute	Tag	Notes
General Series	Modality	(0008,0060)	Set to "US".
	Series Instance UID	(0020,000E)	
	Series Date	(0008,0021)	
	Series Time	(0008,0031)	
	Series Number	(0020,0011)	
	Series Description	(0008,103E)	Elegra Patient Data Screen - Exam Type field.
	Operator Name	(0008,1070)	Elegra Patient Data Screen – Sonographer Initials (maximum of 3 character).
	Requested Attribute Sequence	(0040,0275)	Sent if 'MPPS' option is configured
	>Requested Procedure ID	(0040,1001)	Sent if 'MPPS' option is configured
	>Requested Procedure Step ID	(0040,0009)	Sent if 'MPPS' option is configured
	>Scheduled Procedure Step Description	(0040,0007)	Sent if 'MPPS' option is configured
	>Scheduled Action Item Code Sequence	(0040,0008)	Sent if 'MPPS' option is configured
	>>Code Value	(0008,0100)	Sent if 'MPPS' option is configured
	>>Coding Scheme Designator	(0008,0102)	Sent if 'MPPS' option is configured
	>>Code Meaning	(0008,0104)	Sent if 'MPPS' option is configured
	Performed Procedure Step ID	(0040,0253)	Sent if 'MPPS' option is configured
	Performed Procedure Step Start Date	(0040,0244)	Sent if 'MPPS' option is configured
	Performed Procedure Step Start Time	(0040,0245)	Sent if 'MPPS' option is configured
	Performed Procedure Step Description	(0040,0254)	Sent if 'MPPS' option is configured
	Series Description	(0008,103E)	Elegra Patient Data Screen - Exam Type field.

Table 3.1.2.2.1-2 US Image IOD Attributes Used (cont.)

Module	Attribute	Tag	Notes
General Equipment	Manufacturer	(0008,0070)	Set to "SIEMENS Ultrasound"
	Institution Name	(0008,0080)	Elegra System Presets – Organization Name field.
	Manufacturers Model Name	(0008,1090)	Set to "Elegra".
	Station Name	(0008,1010)	Elegra System Presets – System Location field.
General Image	Image Number	(0020,0013)	Image number is series (1 – n)
	Patient Orientation	(0020,0020)	Zero length attribute.
	Image Date	(0008,0023)	Date the image was captured.
	Image Time	(0008,0033)	Time the image was captured.
	Acquisition Number	(0020,0012)	Set to 1.
Image Pixel	Samples per Pixel	(0028,0002)	Monochrome2 = 1, RGB = 3.
	Rows	(0028,0010)	Set to 666.
	Columns	(0028,0011)	Set to 888.
	Bits Allocated	(0028,0100)	Set to 8.
	Bits Stored	(0028,0101)	Set to 8.
	High Bit	(0028,0102)	Set to 7.
	Pixel Data	(7FE0,0010)	
	Planar Configuration	(0028,0006)	Color-by-pixel. Only sent if Samples per Pixel is greater than 1.
	Photometric Interpretation	(0028,0004)	RGB – for color images Monochrome2 – for grayscale.
	Pixel Representation	(0028,0103)	0000H = unsigned integer.
US Image	Image Type	(0008,0008)	The Defined Terms for Value 3 are the current Application type (e.g. ABDOMIN, OB, etc.).
VOI LUT	Window Center	(0028,1050)	Set to 128.
	Window Width	(0028,1051)	Set to 256.

Table 3.1.2.2.1-2 US Image IOD Attributes Used (cont.)

Module	Attribute	Tag	Notes
SOP Common	SOP Class UID	(0008,0016)	Always US Image – 1.2.840.10008.5.1.4.1.1.6.1
	SOP Instance UID	(0008,0018)	
	Specific Character Set	(0008,0005)	“ISO-IR 100” is sent if system is configured for French or German language, otherwise the attribute is not sent.
Image Plane	Pixel Spacing	(0028,0030)	Pixel Spacing information is only sent for single, full screen, 2d image types (2d image types are b-mode, b-mode with color, b-mode with power).

3.1.2.2.3 Error Handling

The following table indicates the possible response status codes, which a SCP may return following the SCU's C-STORE-RSP command. Only those status responses that indicate some form of error condition are presented to the user.

A successful C-STORE operation will allow the AE to continue to the next action desired by the user.

Table 3.1.2.2.3-1 C-STORE Status Responses

Service Status	Further Meaning	Protocol Codes	Related Fields
Refused	Out of resources.	A7xx	None
Error	Data set does not match SOP Class. Cannot understand.	A9xx	None
		Cxxx	
Warning	Coercion of data Elements. Data set does not match SOP Class. Elements discarded.	B000	None
		B007	
		B006	
Success		0000	None

If the C-STORE operation is not successful, the image(s) are spooled on the SONOLINE Elegra hard drive. Transfer attempts continue at 120 second intervals until either a successful completion of the C-STORE operation occurs, or the image(s) are removed from the transfer-waiting list.

All image storage on the SONOLINE Elegra system hard drive is temporary in nature. The oldest transferred exams are automatically deleted to make room for new exams, on a need to basis. If an attempt is made to store images on a full SONOLINE Elegra system hard drive, the system will attempt to delete the oldest transferred exam data. If no deleteable data exists, a “DISK FULL” message is displayed on the SONOLINE Elegra system display. The user must then have to explicitly delete exams not transferred in order to temporarily store additional images.

When the Storage Commitment option is implemented, the SONOLINE Elegra hard drive will automatically mark images eligible for deletion indicated in the N-EVENT REPORT from the provider.

3.1.2.3 Real World Activity - Print

The user selects “New Patient” at the start of each new patient examination. When the “Print 1” or “Print 2” key is pressed, an association with the assigned DICOM Printer/Print Server is initiated. The Print keys can be assigned to separate printers, or to the same DICOM print device, with separate configurations (i.e. one key for printing grayscale images and one for printing color images).

A separate association is established by this AE when the first image of a film sheet is transferred. The film sheet is printed and the association is closed when the sheet is full. The association is also closed and the pending film sheet printed when the exam is ended by either “End Exam” or “New Patient”.

3.1.2.3.1 Associated Real World Activities

An association is established when the user initiates a “Print To” operation from the Manage Records screen. Individual images or entire exams can be transferred to the selected DICOM Print device. The association is opened when the first image of each selected exam is transferred and closed when the last image transfer is complete. An association is also opened after a network outage, or if images are queued to be printed, or when the system is powered-on and images are queued to be printed.

If desired, the user may set a flag in the “Save Images” activity, which causes the images to be sent both to a network server and the local archive.

3.1.2.3.2 Proposed Presentation Context to a Grayscale Print Server

Table 3.1.2.3.2-1 Grayscale Print Presentation Context Table

Abstract Syntax		Transfer Syntax		Role	Extended Negotiation
Name	UID	Name List	UID List		
Basic Grayscale Print Management Meta SOP Class	1.2.840.10008.5.1.1.9	DICOM Explicit VR Little Endian	1.2.840.10008.1.2.1	SCU	None
Basic Grayscale Print Management Meta SOP Class	1.2.840.10008.5.1.1.9	DICOM Implicit VR Little Endian	1.2.840.10008.1.2	SCU	None

3.1.2.3.2.1 SOP Specific Conformance to Basic Grayscale Print Management Meta SOP Class

The Print AE provides standard conformance of the Grayscale Meta SOP classes as an SCU. Specifically, with respect to the Basic Grayscale Print Management Meta SOP Class this means conformance to the underlying SOP classes:

SOP Class Name	SOP Class UID	Conformance Level
Basic Film Session SOP Class	1.2.840.10008.5.1.1.1	Standard
Basic Film Box SOP Class	1.2.840.10008.5.1.1.2	Standard
Basic Grayscale Image Box SOP Class	1.2.840.10008.5.1.1.4	Standard
Printer SOP Class	1.2.840.10008.5.1.1.16	Standard

All mandatory elements of these classes are supported.

3.1.2.3.2.1.1 SOP Specific Conformance to Basic Film Session SOP Class

DICOM specified usage - M = Mandatory; U = User Option

Table 3.1.2.3.2.1.1-1 Supported DIMSE Services for Basic Film Session SOP Class.

Name	Usage	Description
N-Create	M	Creates the Film Session.
N-Set	U	Not used.
N-Delete	U	Not used.
N-Action	U	Not used.

Table 3.1.2.3.2.1.1-2 Supported Basic Film Session SOP Class Elements

Attribute Name	Attribute Tag	Usage	Range	Description
Number of Copies	(2000,0010)	U	1 to 99	Number of requested film copies.
Print Priority	(2000,0020)	U	HIGH, MED, LOW	set at configuration
Medium Type	(2000,0030)	U	PAPER CLEAR FILM BLUE FILM CURRENT TRANSPARENCY NONE	Media used for hardcopy; may be further limited by print vendor/server
Film Destination	(2000,0040)	U	MAGAZINE PROCESSOR CURRENT	May be further limited by print vendor, and/or print server

3.1.2.3.2.1.2 SOP Specific Conformance to Basic Film Box SOP Class

Table 3.1.2.3.2.1.2-1 Supported DIMSE Services for Basic Film Box SOP Class.

Name	Usage	Description
N-Create	M	Creates the Film Box.
N-Set	U	Not used.
N-Delete	U	Deletes the Film Box. Issued after each film is printed.
N-Action	M	PRINT. Sent after each Film Box is filled, and at the end of the exam to force a print of partially filled Film Box.

Table 3.1.2.3.2.1.2-2 Optional Attributes set for the Basic Film Box SOP Class

Attribute Name	Attribute Tag	Usage	Range	Description
Film Orientation	(2010,0040)	U	PORTRAIT LANDSCAPE	Range may be limited by print server/printer.
Film Size ID	(2010,0050)	U	8INX10IN 14INX17IN 20CMX25CM 35CMX43CM	Range may be limited by print server/printer.
Magnification Type	(2010,0060)	U	REPLICATE BILINEAR CUBIC NONE	Used.
Min. Density	(2010,0120)	U	0-99999	Used - printer specific
Max Density	(2010,0130)	U	0-99999	Used - printer specific
Configuration Information	(2010,0150)	U	Limited by Print server/printer.	Used.
Smoothing Type	(2010,0080)	U	Values depend on Printer	Used.
Border Density	(2010,0100)	U	BLACK WHITE i	where i represents the desired image density in hundredths of OD
Empty Image Density	(2010,0110)	U	BLACK WHITE i	where i represents the desired image density in hundredths of OD
Trim	(2010,0140)	U	YES NO	Used.

3.1.2.3.2.1.3 SOP Specific Conformance to Basic Grayscale Image Box SOP Class**Table 3.1.2.3.2.1.3-1 Supported DIMSE Services for the Basic Grayscale Image Box SOP**

Name	Usage	Description
N-Set	M	The SCP for each potential image of the film box creates an image box instance. Only those instances, which actually contain images, will be updated with the N-SET message.

Table 3.1.2.3.2.1.3-2 Optional Attributes set for the Basic Grayscale Image Box SOP Class

Name	Attribute	Range	Description
Polarity	(2020,0020)	NORMAL REVERSE	Intensity mapping between display and print
Magnification Type	(2010,0060)	REPLICATE, BILINEAR, CUBIC, NONE	Used. Note that Magnification Type is always set to the same value as FILM BOX
Smoothing Type	(2010,0080)	Values depend on Printer	Used. Note that Smoothing Type is always set to the same value as FILM BOX

Table 3.1.2.3.2.1.3-1 Supported DIMSE Services for the Printer SOP Class

Name	Usage	Description
N-Event-Report	M	Ignored and not handled.
N-Get	U	May be issued by this device at any time to get printer status.

Table 3.1.2.3.2.1.3-2 Supported Printer SOP Class Elements

Name	Usage	Range	Description
Printer Status	U	NORMAL WARNING FAILURE	Only WARNING is reported to the user.
Printer Status Information	U	Vendor specific	Reported to user if printer status = WARNING.
Printer Name	U		Used (not reported to user)
Manufacturer	U		Used (not reported to user)
Model Name	U		Used (not reported to user)
Device Serial Number	U		Used (not reported to user)
Software Versions	U		Used (not reported to user)
Date Last Calibration	U		Used (not reported to user)
Last Calibration	U		Used (not reported to user)

3.1.2.3.3 Proposed Presentation Context to a Color Print Server

Table 3.1.2.3.3-1 Color Print Server Presentation Context Table

Abstract Syntax		Transfer Syntax		Role	Extended Negotiation
Name	UID	Name List	UID List		
Basic Color Print Management Meta SOP Class	1.2.840.10008.5.1.1.18	DICOM Explicit VR Little Endian	1.2.840.10008.1.2.1	SCU	None
Basic Color Print Management Meta SOP Class	1.2.840.10008.5.1.1.18	DICOM Implicit VR Little Endian	1.2.840.10008.1.2	SCU	None

3.1.2.3.3.1 SOP Specific Conformance to Basic Color Print Management Meta SOP Class

The Print AE provides standard conformance to the color printing Meta SOP classes as an SCU. Specifically, with respect to the Basic Color Print Management Meta SOP Class this means conformance to the underlying SOP classes:

SOP Class Name	SOP Class UID	Conformance Level
Basic Film Session SOP Class	1.2.840.10008.5.1.1.1	Standard
Basic Film Box SOP Class	1.2.840.10008.5.1.1.2	Standard
Basic Color Image Box SOP Class	1.2.840.10008.5.1.1.4.1	Standard
Printer SOP Class	1.2.840.10008.5.1.1.16	Standard

3.1.2.3.3.1.1 SOP Specific Conformance to Basic Color Image Box SOP Class

The Basic Color Image Box SOP Class makes identical use of the *Basic Film Session SOP Class*, *Basic Film Box SOP Class* and *Printer SOP Class* elements, which have been previously described, for grayscale image printing. Therefore these will not be described again in this section on color printing. However, it should be noted that certain of the attributes, such as Medium Type which is defined in the Basic Film Session SOP Class, are highly likely to require printer/print server specific media.

Table 3.1.2.3.3.1.1-1 Supported DIMSE Services for the Basic Color Image Box SOP Class

Name	Usage	Description
N-Set	M	The SCP for each potential image of the film box creates an image box instance. Only those instances, which actually contain images, will be updated with the N-SET message.

Table 3.1.2.3.3.1.1-2 Optional attributes set for the Basic Color Image Box SOP Class

Name	Attribute	Range	Description
Planar Configuration	(0028,0006)	Color-by-plane	Red plane, Green plane, Blue plane.
Polarity	(2020,0020)	REVERSE NORMAL	Used
Magnification Type	(2010,0060)	REPLICATE BILINEAR CUBIC NONE	Used.
Smoothing Type	(2010,0080)	Values depend on Printer	Used.

The Printer SOP Class behavior is identical to that used for grayscale printing.

3.1.2.3.4 Error Handling

Table 3.1.2.3.4-1 Supported Error Codes for Printer Classes

Service Status	Further Meaning	Protocol Codes
Success	Film accepted for Printing	0000
Warning	All	B60x
Failure	Printing not successful	C60x

3.1.2.4 Real World Activity - Worklist

A separate Network association is established by the AE for each Worklist query operation, with only one active query at a time. The association is closed at completion of the query.

3.1.2.4.1 Proposed Presentation Context

Table 3.1.2.4.1-1 Worklist Presentation Context Table

Abstract Syntax		Transfer Syntax		Role	Extended Negotiation
Name	UID	Name List	UID List		
Modality Worklist Information Model – FIND	1.2.840.10008.5.1.4.31	Explicit VR Little Endian	1.2.840.10008.1.2.1	SCU	None
Modality Worklist Information Model – FIND	1.2.840.10008.5.1.4.31	Implicit VR Little Endian	1.2.840.10008.1.2	SCU	None

The SONOLINE Elegra system will always act as an SCU and be the client in a client-server model.

3.1.2.4.1.1 SOP Specific Conformance to Modality Worklist Service SOP Classes

The Worklist AE provides conformance to the following DICOM Service SOP Classes as an SCU all at a standard extended level of conformance:

Table 3.1.2.4.1.1-1 Supported SOP Classes

Service SOP Class Name	SOP Class UID	Conformance Level
Modality Worklist Information Model – FIND	1.2.840.10008.5.1.4.31	Standard Extended

The following table provides the list of attributes requested in the Modality Worklist Query.

3.1.2.4.1.1-2 Modality Worklist Information Model Attributes

Module	Attribute name	Tag	Match Type	Notes
SOP Common	Specific Character Set	(0008,0005)	--	The SONOLINE Elegra ignores this attribute.
Scheduled Procedure Step	Scheduled Procedure Step Sequence	(0040,0100)	SQ	
	>Scheduled Station AE Title	(0040,0001)	UV	See Note 2.
	>Scheduled Procedure Step Start Date	(0040,0002)	SV	See Note 2.
	>Scheduled Procedure Step Start Time	(0040,0003)	UV	
	>Modality	(0008,0060)	SV	Always "US" See Note 2.
	>Scheduled Performing Physician	(0040,0006)	UV	
	>Scheduled Procedure Step Description	(0040,0007)	UV	Used for Exam Type - returned in image as Study Description, if Study Description is not returned.
	Scheduled Action Item Code Sequence	(0040,0008)	SQ	Either the Scheduled Procedure Step Description (0040,0005) or the Scheduled Action Item Code Sequence (0040,0008)
	>Scheduled Procedure Step ID	(0040,0009)	UV	

3.1.2.4.1.1-2 Modality Worklist Information Model Attributes (cont.)

Module	Attribute name	Tag	Match Type	Notes
Requested Procedure	Requested Procedure ID	(0040,1001)	UV	See Note 2.
	Referenced Study Sequence	(0008,1110)	SQ	Sequence Describing the scheduled Action Items following a specified coding scheme. This sequence contains one or more action items.
	Requested Procedure Description	(0032,1060)	UV	Used for Exam Type - returned in image as Study Description if Study Description and Scheduled Procedure Step Description are not returned.
	Study Instance UID	(0020,000D)	UV	
Imaging Service Request	Accession Number	(0008,0050)	SV	See Note 2.
	Referring Physician Name	(0008,0090)	UV	
Patient Identification	Patient's Name	(0010,0010)	WC	See Note 2.
	Patient ID	(0010,0020)	SV	See Note 2.
Patient Demographic	Patient's birth date	(0010,0030)	UV	
	Patient's Sex	(0010,0040)	UV	
	Patient's Size	(0010,1020)	UV	
	Patient's Weight	(0010,1030)	UV	See Note 2.
	Study Description	(0008,1030)	UV	Used for Exam Type. (See Note 1) See Note 2.
	Admitting Diagnosis Description	(0008,1080)	UV	See Note 1.

Note 1: These attributes are not part of the Modality Worklist Information Model, and are Standard Extended SOP Class attributes. These attributes are optional, and their support is not required by SCPs receiving SONOLINE Elegra Worklist queries.

Note 2: These attributes are available as query criteria from the Worklist 'Search Menu'.

Matching Key Types	
SV	Single Value matching
WC	Wild Card matching
SQ	Sequence matching
UV	Universal matching
DR	Date Range matching

3.1.2.4.2 Error Handling

The following table indicates the possible response status codes, which a SCP may return following the SCU's C-FIND command. Only those status responses that indicate some form of error condition are presented to the user. Related fields are not used.

Table 3.1.2.4.2-1 C-STORE Status Responses

Service Status	Further Meaning	Protocol Codes	Related Fields
Refused	Out of resources	A700	None
Failed	Identifier does not match SOP Class	A900	None
	Unable to process	Cxxx	None
Cancel	Matching terminated due to Cancel request	FE00	None
Success	Matching is complete - No final Identifier is supplied.	0000	None
Pending	Matches are continuing - Current Match is supplied and any Optional Keys were supported in the same manner as Required Keys.	FF00	None
	Matches are continuing - Warning that one or more Optional Keys were not supported for existence for this Identifier.	FF01	None

3.1.2.5 Real World Activity - Modality Performed Procedure Step

This operation allows the AE to create an instance of the Modality Performed Procedure step SOP Class (MPPS) and provide information about a specific real world Performed Procedure step that is under control of the SCU. This operation is invoked through the DIMSE N-CREATE service.

A list of scheduled procedures will be accessible from the patient data UI. One or more procedure codes can be highlighted to allow grouping of the codes. In the event of multiple highlighted codes, all highlighted scheduled procedures will be referenced to one performed procedure step. The Performed procedure step User Interface allows the operator to set the status of the performed procedure code, scheduled procedure code, and procedure description. The system shall establish an association for each N-CREATE and N-SET.

Starting a Performed Procedure Step

When the user depresses the ‘Exit’ button on the patient data menu a performed procedure SOP Class instance will be created using the N-CREATE DIMSE service for the selected scheduled procedure.

Ending a Performed Procedure Step

When the user selects ‘Completed’ or ‘Discontinued’ from the PPS User Interface, the performed procedure step will be closed using the N-SET DIMSE service. Once this event has been sent, no more images will be transferred referencing the scheduled procedure(s). If the ‘performed procedure code’ field is left blank, the scheduled procedure code of the first scheduled procedure shall be sent as the performed procedure code and performed procedure description.

New Patient Request

If the ‘New Patient’ button is selected and there are opened performed procedure steps, the user shall be prompted for a closure status for each opened procedure step by the PPS User Interface. All opened procedure steps must be closed before any ‘new patient’ data can be entered.

System Shutdown

If the user selects the ‘System Shutdown’ key and there are opened performed procedure steps, the user will be prompted for a closure status for each opened procedure step. All opened procedure steps must be closed before the system can be shutdown.

Error Handling

If at any time the MPPS server is unavailable, the user will be prompted by a pop up message ‘MPPS Device not available’ asking the operator to select either ‘Retry’ or ‘Continue’. Selecting ‘Retry’ causes the system to attempt an immediate association to the MPPS server. Selecting ‘Continue’ will allow the user to continue working. Data transfer will be attempted periodically in the background.

3.1.2.5.1 Proposed Presentation Context

Table 3.1.2.5.1-1 Modality Performed Procedure Step Presentation Context Table

Abstract Syntax		Transfer Syntax		Role	Extended Negotiation
Name	UID	Name List	UID List		
Modality Performed Procedure Step	1.2.840.10008.3.1.2.3.3	Explicit VR Little Endian	1.2.840.10008.1.2.1	SCU	None
Modality Performed Procedure Step	1.2.840.10008.3.1.2.3.3	Implicit VR Little Endian	1.2.840.10008.1.2	SCU	None

The SONOLINE Elegra system will always act as an SCU and be the client in a client –server model

3.1.2.5.1.1 SOP Specific Conformance to Modality Performed Procedure Step SOP Classes

The Modality Performed Procedure Step AE provides conformance to the following DICOM Service SOP Classes as an SCU all at a standard level of conformance.

Table 3.1.2.5.1.1-1 Supported SOP Classes

Service SOP Class Name	SOP Class UID	Conformance Level
Modality Performed Procedure Step	1.2.840.10008.3.1.2.3.3	Standard

The following table provides the list of attributes supported by the AE in the implementation of MPPS SOP Class including N-CREATE, N-SET and Final State attributes.

3.1.2.5.1.1-2 Modality Performed Procedure Step Module Attributes

Attribute Name	Tag	Req. Type N-CREATE (SCU/SCP)	Req. Type N-SET (SCU/SCP)	Requirement Type Final State	AE Implem ented
Specific Character Set	(0008,0005)	1C/1C Required if an extended or replacement character set is used	Not Allowed		X
Performed Procedure Step Relationship					
Scheduled Step Attribute sequence	(0040,0270)	1/1	Not Allowed		X
>Study Instance UID	(0020,000D)	1/1	Not Allowed		X
>Referenced Study Sequence	(0008,1110)	2/2	Not Allowed		X
>>Referenced SOP Class UID	(0008,1150)	1C/1 (Required if Sequence Item is present))	Not Allowed		X
>>Referenced SOP Instance UID	(0008,1155)	1C/1 (Required if Sequence Item is present))	Not Allowed		X
>Accession Number	(0008,0050)	2/2	Not Allowed		X
>Requested Procedure ID	(0040,1001)	2/2	Not Allowed		X

3.1.2.5.1.1-2 Modality Performed Procedure Step Module Attributes (cont.)

Attribute Name	Tag	Req. Type N-CREATE (SCU/SCP)	Req. Type N-SET (SCU/SCP)	Requirement Type Final State	AE Implem ented
>Requested Procedure Description	(0032,1060)	2/2	Not Allowed		X
>Scheduled Procedure Step ID	(0040,0009)	2/2	Not Allowed		X
>Scheduled Procedure Step Description	(0040,0007)	2/2	Not Allowed		X
>Scheduled Action Item code Sequence	(0040,0008)	2/2	Not Allowed		X
>>Code Value	(0008,0100)	1C/1 (Required if Sequence Item is present)	Not Allowed		X
>>Coding Scheme Designator	(0008,0102)	1C/1 (Required if Sequence Item is present)	Not Allowed		X
>>Code Meaning	(0008,0104)	3/3	Not Allowed		
Patient's Name	(0010,0010)	2/2	Not Allowed		X
Patient ID	(0010,0020)	2/2	Not Allowed		X
Patient's Birth Date	(0010,0032)	2/2	Not Allowed		X
Patient's Sex	(0010,0040)	2/2	Not Allowed		X
Referenced Patient Sequence	(0008,1120)	2/2	Not Allowed		X
>Referenced SOP Class UID	(0008,1150)	1C/1 (Required if Sequence Item is present)	Not Allowed		X
>Referenced Instance UID	(0008,1155)	1C/1 (Required if Sequence Item is present)	Not Allowed		X

3.1.2.5.1.1-2 Modality Performed Procedure Step Module Attributes (cont.)

Attribute Name	Tag	Req. Type N-CREATE (SCU/SCP)	Req. Type N-SET (SCU/SCP)	Requirement Type Final State	AE Implem ented
Performed Procedure Step Information					
Performed Procedure Step ID	(0040,0253)	1/1	Not Allowed		X
Performed Station AE Title	(0040,0241)	1/1	Not Allowed		X
Performed Station Name	(0040,0242)	2/2	Not Allowed		X
Performed Location	(0040,0243)	2/2	Not Allowed		
Performed Procedure Step Start Date	(0040,0244)	1/1	Not Allowed		X
Performed Procedure Step Start Time	(0040,0245)	1/1	Not Allowed		X
Performed Procedure Step Status	(0040,0252)	1/1	3/1		X
Performed Procedure Step Description	(0040,0254)	2/2	3/2		X
Performed Procedure Type Description	(0040,0255)	2/2	3/2		X
Procedure Code Sequence	(0008,1032)	2/2	3/2		X
>Code Value	(0008,0100)	1C/1 (Required if Sequence Item is present)	1C/1 (Required if Sequence Item is present)		X
>Coding Scheme Designator	(0008,0102)	1C/1 (Required if Sequence Item is present)	1C/1 (Required if Sequence Item is present)		X
>Code Meaning	(008,0104)	3/3	3/3		

3.1.2.5.1.1-2 Modality Performed Procedure Step Module Attributes (cont.)

Attribute Name	Tag	Req. Type N-CREATE (SCU/SCP)	Req. Type N-SET (SCU/SCP)	Requirement Type Final State	AE Implem ented
Performed Procedure Step End Date	(0040,0250)	3/3	3/3	1	
Performed Procedure Step End Time	(0040,0251)	2/2	3/1	1	X
Image Acquisition Results					
Modality	(0008,0060)	1/1	Not Allowed		X
Study ID	(0020,0010)	2/2	Not Allowed		X
Performed Action Item Code Sequence	(0040,0260)	2/2	3/1		X
>Code Value	(0008,0100)	1C/1 (Required if Sequence Item is present)	1C/1 (Required if Sequence Item is present)		X
>Coding Scheme Designator	(008,0102)	1C/1 (Required if Sequence Item is present)	1C/1 (Required if Sequence Item is present)		X
>Code Meaning	(0008,0104)	3/3	3/3		
Performed Series Sequence	(0040,0340)	2/2	3/1	1 (See Note 2)	X
>Performing Physician's Name	(0008,1050)	2C/2 (Required if Sequence Item is present)	2C/2 (Required if Sequence Item is present)	2	X
>Protocol Name	(0008,1030)	1C/1 (Required if Sequence Item is present)	(Required if Sequence Item is present)	1	X

3.1.2.5.1.1-2 Modality Performed Procedure Step Module Attributes (cont.)

Attribute Name	Tag	Req. Type N-CREATE (SCU/SCP)	Req. Type N-SET (SCU/SCP)	Requirement Type Final State	AE Implem ented
>Operators Name	(0008,1070)	2C/2 (Required if Sequence Item is present)	2C/2 (Required if Sequence Item is present)	2	X
>Series Instance UID	(0020,000E)	1C/1 (Required if Sequence Item is present)	1C/1 (Required if Sequence Item is present)	1	X
>Series Description	(0008,103E)	2C/2 (Required if Sequence Item is present)	2C/2 (Required if Sequence Item is present)	2	X
>Retrieve AE Title	(0008,0054)	2C/2 (Required if Sequence Item is present)	2C/2 (Required if Sequence Item is present)	2	X
>Referenced Image Sequence	(0008,1140)	2C/2 (Required if Sequence Item is present)	2C/2 (Required if Sequence Item is present)		X
>>Referenced SOP Class UID	(0008,1150)	1C/1 (Required if Sequence Item is present)	1C/1 (Required if Sequence Item is present)		X
>>Referenced SOP Instance UID	(0008,1155)	1C/1 (Required if Sequence Item is present)	1C/1 (Required if Sequence Item is present)		X
>Reference Standalone SOP Instance Sequence	(0040,0220)	2C/2 (Required if Sequence Item is present)	2C/2 (Required if Sequence Item is present)		X

3.1.2.6 Real World Activity – Storage Commitment

This operation allows the AE to create an instance of the Storage Commitment SOP Class and to provide information about a specific Real World Activity that is under the control of the SCU. The AE invokes a request for safekeeping of images by the N-ACTION REQUEST. Referenced in the N-ACTION Request is the SOP instance UID(s) for all STORE Class objects requesting commitment by the SCU.

The SCU waits for the return of a successful N-ACTION RESPONSE Status Code applicable for the associated request indicating whether the commitment request was successful or a failure. The AE waits for the N-EVENT REPORT from the SCP for an infinite period of time. The AE is capable of accepting the N-EVENT-REPORT on the same or different association. The N-EVENT REPORT notification contains the status of the imbedded SOP instances referenced in the N-ACTION REQUEST. SOP instances marked as 'successful' will be eligible for deletion from the system hard drive. Storage Commitment can be toggled on any STORE device configured on the SONOLINE Elegra system from the System Pre-sets page.

3.1.2.6.1 Proposed Presentation Context

Presentation Context Table					
Abstract Syntax		Transfer Syntax		Role	Extended Negotiation
Name	UID	Name List	UID List		
Storage Commitment Push Model	1.2.840.10008.1.20.1	Explicit VR Little Endian	1.2.840.10008.1.2.1	SCU	None
Storage Commitment Push Model	1.2.840.10008.1.20.1	Implicit VR Little Endian	1.2.840.10008.1.2	SCU	None

The SONOLINE Elegra system will act as an SCU in the 'Push Model' Storage Commitment SOP Class.

3.1.2.6.1.1 SOP Specific Conformance to Storage Commitment SOP Class

The Storage Commitment AE provides conformance to the following DICOM Service SOP Classes as an SCU all at a standard level of conformance.

Table 3.1.2.6.1.1-1 Supported SOP Classes

Service SOP Class Name	SOP Class UID	Conformance Level
Storage Commitment – Push model	1.2.840.10008.1.20.1	Standard

The following table provides the list of attributes supported by the AE in the implementation of Storage Commitment SOP Class including N-ACTION, N-EVENT Report and Final State attributes.

Table 3.1.2.6.1.1-2 Storage Commitment Request – Action Information

Action Type Name	Action Type ID	Attribute	Tag	Requirement Type SCU/SCP
Request Storage Commitment	1	Transaction UID	(0008,1195)	1/1
		Referenced SOP Sequence	(0008,1199)	1/1
		>Referenced SOP Class UID	(0008,1150)	1/1
		>Referenced SOP Instance UID	(0008,1155)	1/1
		Referenced Study Component Sequence	(0008,1111)	1C/1
		>Referenced SOP Class UID	(0008,1150)	1/1
		>Referenced SOP Instance UID	(0008,1155)	1/1

Table 3.1.2.6.1.1-3 Storage Commitment Result – Event Information

Event Type Name	Event Type ID	Attribute	Tag	Requirement Type SCU/SCP
Storage Commitment Request Successful	1	Transaction UID	(0008,1195)	-/1
		Referenced SOP Sequence	(0008,1199)	-/1
		>Referenced SOP Class UID	(0008,1150)	-/1
		>Referenced SOP Instance UID	(0008,1155)	-/1
Storage Commitment Request Complete Failures Exist	2	Transaction UID	(0008,1195)	-/1
		Referenced SOP Sequence	(0008,1199)	-/1C
		>Referenced SOP Class UID	(0008,1150)	-/1
		>Referenced SOP Instance UID	(0008,1155)	-/1
		Failed SOP Sequence	(0008,1198)	-/1
		>Referenced SOP Class UID	(0008,1150)	-/1
		>Referenced SOP Instance UID	(0008,1155)	-/1
>Failure Reason	(0008,1197)	-/1		

4 Communication Profiles

All SONOLINE Elegra system application entities utilize the DICOM 3.0 TCP/IP communication support as defined in PS3.8 (Part 8) of the DICOM 3.0 Standard.

4.1 TCP/IP Stack Supported

Each process inherits its TCP/IP stack from the operating system TCP/IP stack of the SONOLINE Elegra system. Port number 5000 is used for DICOM communication with the SONOLINE Elegra system.

4.1.1 Physical Media Supported

Standard representations of IEEE 802.3 (10Base2 (“thinwire”), Fiber Optic (both SMA and ST style connectors) and 10BaseT (“twisted pair”) is supported and the system interfaces and transceivers configured to meet customer site-specific requirements.

5 Extensions/Specializations/Privatizations

5.1 Standard Extended/Specialized/Private Syntaxes

Private elements used in the SONOLINE Elegra system DICOM implementation are noted in the table below.

5.2 Private Transfer Syntaxes

The SONOLINE Elegra system implements two private field group elements in the STORE IOD object. They are used internally to support image acquisition and retrieval

Table 5.2-1 Siemens Private Data Elements

Element Name	Tag	VR	Description
Private Creator	(0029,0010)	LO	Set to 1.3.12.2.1107.5.5.1
3D Image Bookmark	(0029,1000)	OB	Binary Data for 3D Reconstruction

6 Configuration

SONOLINE Elegra Networking and DICOM parameters can be configured through the SONOLINE Elegra System Presets Menu screens. The following configuration is supported:

- Basic system
- Network (local and remote)
- DICOM Store
- Storage Commitment
- DICOM Print
- DICOM Worklist
- DICOM Modality Performed Procedure Step
- Exam Types
- External Equipment

6.1 Basic System Configuration

The following system parameters can be configured via the SONOLINE Elegra System Presets Basic Menu screens. These parameters are mapped to DICOM image attributes:

- Organization Name
- Department Name
- System Location

6.1.1 Organization Name

The user can enter the organization (i.e. hospital, clinic, etc.) as a text string in the Organization Name field of the System Presets - Basic menu. The Organization Name field is transferred to DICOM devices as Institution Name - DICOM data element (0008, 0080).

6.1.2 Department Name

The user can enter the department name (i.e. ultrasound lab, OB/Gyn, etc.) as a text string in the Department Name field of the System Presets - Basic menu. The Department Name field is transferred to DICOM devices as Institutional Department Name - DICOM data element (0008, 1040).

6.1.3 System Location

The user can enter the location where the ultrasound exam(s) are being performed in the System Location field of the System Presets - Basic menu. The System Location field will be transferred to DICOM devices as Station Name - DICOM data element (0008, 1010).

6.2 DICOM Network Configuration

DICOM and networking parameters can be configured for both the local SONOLINE Elegra device and remote DICOM service class providers through the System Presets DICOM Network Menu.

6.2.1 Local

The SONOLINE Elegra local network parameters are configurable. The following network parameters can be configured for SONOLINE Elegra device:

- Host Name (i.e. Elegra)
- IP address
- Network IP mask
- DICOM Application Entity Title (default = SMSUG_STORE)
- Network Time-out (DICOM Association Response timer - in seconds). One timer value is used for all DICOM network transfers.

6.2.2 Remote

Multiple DICOM service class providers can be configured through the system presets. The following network parameters can be configured for each remote device:

- Host name
- IP address
- Router/Gateway Host Name
- Router/Gateway IP address

6.3 DICOM Store Configuration

Remote DICOM Storage service class providers are configured through the DICOM - Store page of the System Presets menu. The following parameters can be configured:

- AET - Application Entity Title
- Port number
- Implementation Class UID
- Image types accepted (RGB and Monochrome, or Monochrome only)
- Transfer at End Exam (check boxes) - allows the user to select whether images are transferred to the destination store device as they are acquired (i.e. In Progress Review), or are transferred when the patient exam ends, either by the "End Exam" key or "New Patient" button.

6.4 DICOM Storage Commitment

Remote DICOM Storage commitment providers are configured through the DICOM Store page of the System Presets menu. Select a Host Name; toggle the 'Storage Commitment' button to activate.

6.5 DICOM Worklist Configuration

Remote DICOM Worklist Service Class Providers are configured through the DICOM - Worklist page of the System Presets. The following parameters can be configured for each Worklist server:

- AET - Application Entity Title
- Port number
- ICUID - Implementation Class UID
- 'Active' pushbutton – makes the current selected device the active Worklist server.

6.6 DICOM Performed Procedure Step Configuration

Remote DICOM Modality Performed Procedure Step service class providers are configured through the DICOM - Modality Performed Procedure Step page of the System Presets. The following parameters can be configured for each Worklist server:

- AET - Application Entity Title
- Port number
- ICUID - Implementation Class UID

'Active' pushbutton – makes the current selected device the active Modality Performed Procedure Step server.

6.7 DICOM Print Configuration

For each DICOM Print server, the following data is configurable by the user using the System Presets DICOM Print User Interface. The user can change each element at any time during the operation of the SONOLINE Elegra system. The effect of changing parameters of the DICOM Print server will be seen at the next film sheet. The current film sheet is not affected by changing these parameters.

Table 6.7-1 User Configurable Printer parameters

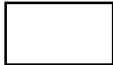
Parameter	Description
Printer Type:	Color or Black and White - depends on printer
Film Size	Select the size of the film - 8x10 inches, 11x17 inches, 20x25 cm., and 35x43 cm.
Film Orientation	Select from Portrait:  or Landscape: 

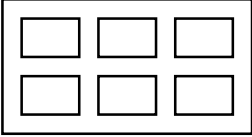
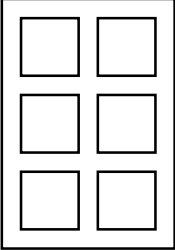
Display Format	<p>You must supply the number of rows and columns of images on the printed sheet. For example, a 6 on 1 print with Landscape mode should have 3 columns and 2 rows:</p>  <p>A 6 on 1 with Portrait mode would have 2 columns and 3 rows:</p> 
Print Priority	HIGH, MEDIUM or LOW
Medium Type	PAPER, CLEAR FILM, BLUE FILM, TRANSPARENCY or CURRENT (to use the currently loaded media)
Film Destination	MAGAZINE, PROCESSOR or CURRENT
Max. Density	Used to define the Black value - printer specific
Min. Density	Used to define the White value - printer specific
Smoothing Type	Printer specific value
Border Density	BLACK , WHITE or i border around film
Empty Image Density	BLACK,WHITE, or i empty image segments on film
Trim	Yes/No to having a border around each image
Polarity	Normal/reverse. Normal means black is printed as black. Reverse means the grayscale is inverted so that black comes out as white and white as black.
Configuration Information:	Printer Specific values

6.8 Exam Types Configuration

User configurable Exam Types are supported (as free form text) through the System Presets Exam Types screen. These user defined Exam types are available for selection in the Patient Data screen, during patient registration. Exam types are mapped to the DICOM Study Description (0008,1030) and Series Description (0008,103E) image attributes.

6.9 External Equipment Configuration

The SONOLINE Elegra user can configure “Hard Key” to “Output Device” mapping through the System Presets - External Equipment menu. Images are acquired and sent to the assigned device when the user presses the associated key. The following key assignments are supported:

- **Store to Disk** – This key can be assigned to any configured DICOM Store device, or the DEFF MO Disk.
- **Print 1** – This key can be assigned to any configured DICOM Printer, or OEM printer device.
- **Print 2** – This key can be assigned to any configured DICOM Printer, or OEM printer device.

7 Support of Extended Character Sets

The “ISO-IR 100” Latin Alphabet 1 Extended character set is supported by the SONOLINE Elegra system.

8 References

Specifications of the DICOM 3.0 standard may be obtained from ACR-NEMA for customers who require detailed information.

9 Glossary

ACR-NEMA

American College of Radiology - National Electrical Manufacturer's Association

AE

Application Entity

Conformance Statement

A formal statement associated with a specific implementation of the DICOM Standard. It specifies the Service Classes, Information Objects, Communications Protocols and Media Storage Application Profiles supported by the implementation

DICOM 3.0

Digital Imaging and Communications in Medicine, Version 3.0.

DIMSE

DICOM Message Service Element

DIMSE C-Store

DICOM Message Service Element, Composite Store

Ethernet

Network methodology devised in 1976 by DIX (DEC/Intel/Xerox) which is the most common in practice today.

IOD

Information Object Definition

MPPS

Modality Performed Procedure Step

MWL

Modality Worklist

PACS

Picture Archiving and Communications Systems

PDU

Protocol Data Unit

RWA

Real-World Activity

SCP

Service Class Provider

SCU

Service Class User

SOP

Service-Object Pairs

UID

Unique identifier