

Second Order Shimming of High Field Magnets

Second Order Shimming of High Field Magnets

Michael Wendt, Ph. D.

Siemens Medical Solutions USA, Inc.



[1]
Field inhomogeneity at the edge of the field of view causes images distortion. The field inhomogeneity destroys the linear dependency of Larmor frequency and spatial locations – spins get misplaced.



[2]
Fat-suppression techniques based on chemical shift will fail in magnets with a bad shim. Note the bright and dark regions of the fatty tissue.

Shimming Magnets? Why would I do that?

Shimming in magnet technology refers to the process of removing small inhomogeneities which are present in the magnetic field. Technically, it is not possible to produce magnets with a perfectly homogeneous field (typical: ± 100 ppm). This is due to construction limits, the large number of variables in the manufacturing process, mechanical and electrical tolerances, as well as the many surrounding structures at the site. However, even if magnets could be manufactured with a perfectly homogeneous magnetic field, the subject placed in the field would definitely destroy this perfect world, and we would have to shim the magnet regardless of its original perfect design.

Shimming may be passive or active. Passive shimming is the first attempt to improve the field homogeneity during the installation of the magnet by placing pieces of metal at specific locations on the outside surface of the scanner. Active shimming uses specifically designed coils (their design is similar to that of the gradient coils). The electrical current running through these shim coils can be adjusted and is optimized to fine tune the homogeneity of the field.

Ok, I can shim a magnet and make the magnetic field more homogeneous, but why would I want to do this? Is it worth all the effort?

During an MRI experiment, the gradients change the local magnetic field strength and by that the Larmor frequency of the spins. When the data collection is complete, and the raw data space (k-space) is filled, the Fourier-transformation maps the different frequencies to the spatial origin of the spins (different frequency = different spatial location). For this mathematical process, it is totally irrelevant what caused the frequency shift: a gradient or a non-homogeneity in the magnetic field. The frequency shift caused by the non-homogeneous magnetic field is a distortion that cannot be removed by any post processing [1].

How does active shimming work?

As mentioned earlier, additional coils (i. e. shim coils) are needed to achieve an active shim. These shim coils are similar in design to gradient coils. The magnetic field created by each coil set is proportional to the current running through the coils. During the shim process, a 3D gradient echo sequence acquires volumetric data of the region to be shimmed, and a computer program analyzes the collected data to estimate the current needed in each shim coil to optimize the magnetic field homogeneity. The situation is comparable to a large, irregularly shaped room with niches and corners that need to be lighted in the most homogeneous way possible. One big light source in the center of the room is not going to do the job (i. e. no light in the niches and behind corners). We need additional light sources (shim coils). The more the better.

The trick for reaching a good shim is to create a good (i. e. most accurate) mathematical model of the magnetic field to be optimized. Could you imagine coming up with a mathematical equation representing the brightness of the light in a room at every possible position? The engineers designing these kind of coils did come up with such equations. Actually, the concept behind the solution is pretty straightforward: Let's take simple equations and add them all up until we get a good estimation of the real world (that's what we then call a "complicated equation"). The real world would then be estimated as follows:

$$^{[1]} B_0 + 3 \text{ linear terms} + 5 \text{ 2}^{\text{nd}} \text{ order terms} + 7 \text{ 3}^{\text{rd}} \text{ order terms} + 9 \text{ 4}^{\text{th}} \text{ order terms} + \dots$$

When using more mathematical terms, we would call this a Taylor series expansion. The first few terms of this Taylor series are B_0 , three linear (first order) terms representing the inhomogeneity of the field in the x, y and the z direction, and the five terms of second order representing bent curves in space. You can find a plot of the linear term in [3], [4], [5] and [6] show plots of the second order terms.

Every MR vendor has the three basic linear shim coils correcting the field in the x, y, and z-direction.

[3]

Plot of the first order shim along the z axis. The set of coils needed to create this field is identical to the gradient coil set. The shim can be accomplished by adding the correction (i.e. shim) current on top of the current creating the gradient field.

Magnetic Field due to A1 gradient

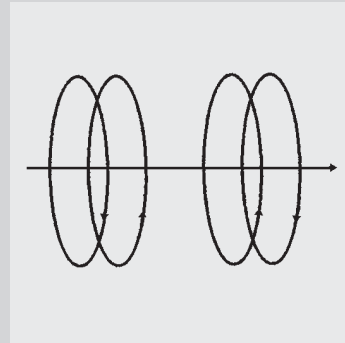
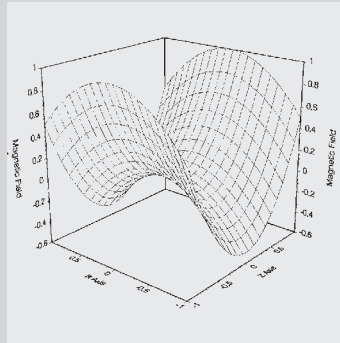
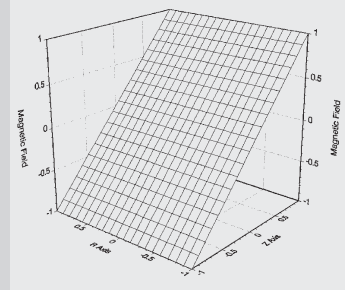

[4]

Plot of the second order shim in the z^2 direction and the shim coil set required to produce this field. This additional hardware is not included in the standard gradient set; special equipment is needed to perform the second order shim.

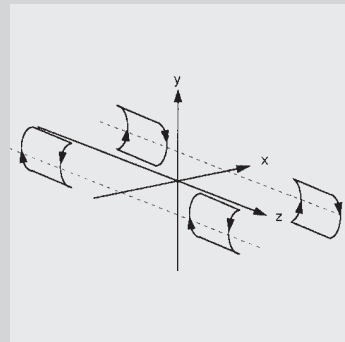
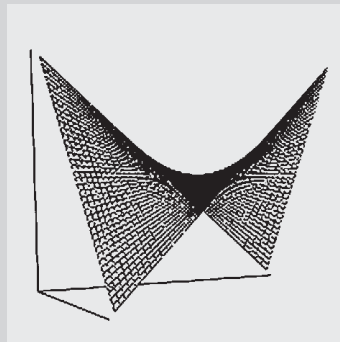

[5]

Plot of the second order shim in the zy or zx direction and the shim coil set required to produce this field. This additional hardware is not included in the standard gradient set; special equipment is needed to perform the second order shim.

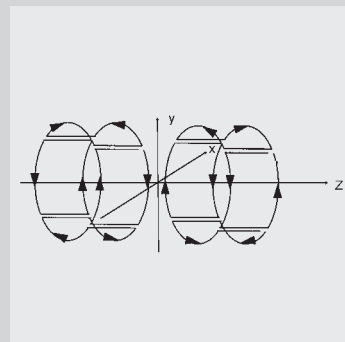
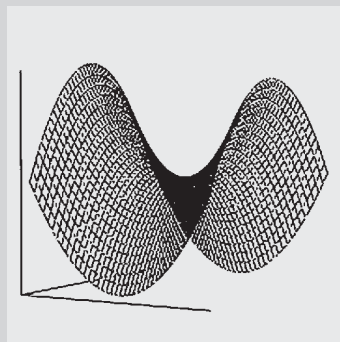

[6]

Plot of the second order shim in the xy and x^2-y^2 directions, and the shim coil set required to produce this field. This additional hardware is not included in the standard gradient set; special equipment is needed to perform the second order shim.

To be more specific, there is one shim coil for the x-direction, one for the y-direction, and one for the z-direction. As these are the direct axes of the scanner's coordinate system, they are referred to as the first order shim. A drawing representing the linear shim directions is presented in [3]. As these directions are identical to the standard gradient directions, this first order shim can be accomplished by driving an offset current through the gradient coils (i.e. no additional hardware required.) This current is creating a field that is directly inverting the field distortion in this direction. However, since all shim coils need to be embedded into the gradient coil, they are pretty expensive, and most of the manufacturers do not incorporate any additional shim coils into their system design. As a high-technology company, Siemens includes five additional shim coils (and power supplies to drive the current through the coils) in their systems to improve the field homogeneity even further.

These additional shim coils are referred to as the second order shim coils set. This set of coils improves the field homogeneity in the zy, zx, xyz, z^2 , and x^2-y^2 directions of the field. zy, zx, and xy are pretty obvious (if not: the direction at 45° between the z and the y axis, and the other axes respectively). The z^2 direction is taking care of the field inhomogeneity along a curve that represents the z^2 function; a plot of this direction is shown in [4].

Bottom Line

Siemens is the only clinical MR manufacturer offering a second order shim, and thereby increasing the magnetic field homogeneity. This is available to our customers as the **Advanced High Order Shim Option**. Applying the second order shim increases the volume within the scanner that is characterized by a homogeneous magnetic field. And this then enables (or is essential for) MR technologies like spectroscopy, fMRI, EPI, and chemical shift fat-suppression. Furthermore, it is the key technology in applications based on phase shift, like temperature sensitive MRI or phase sensitive sequences like True FISP.



Please contact in USA:

Siemens Medical Solutions USA, Inc.
 51 Valley Stream Parkway
 Malvern, PA 19355
 Tel: 610-448-4500
 Fax: 610-448-2254

Please contact in Japan:

Siemens-Asahi
 Medical Technologies Ltd.
 Takanawa Park Tower 14 F
 20-14, Higashi-Gotanda 3-chome
 Shinagawa-ku
 Tokyo 141-8641
 (+81) 354 234 001

Please contact in Asia:

Siemens Medical Solutions
 Asia Pacific Headquarters
 c/o Siemens Advanced Engineering Pte Ltd.
 Block 28 Ayer Rajah Crescent No. 06-08
 Singapore 139959
 (+65) 8 715 888

**This is fascinating!
 Can you elaborate on the mathematics behind it?**

The magnetic field is distributed according to the Laplace equation:

$$^{[2]} \nabla^2 (B_x, B_y, B_z) = 0$$

In MRI we try to accomplish a very homogeneous magnetic field in the B_z direction, leaving us with:

$$^{[3]} \nabla^2 B_z = 0$$

This mathematical problem can be solved in a spherical coordinate system:

$$^{[4]} B_z(r, \theta, \phi) = \sum_{n=0}^{\infty} \sum_{m=0}^n \left(\frac{r}{R_0} \right)^n (A_n^m \cdot \cos(m\phi) + B_n^m \cdot \sin(m\phi)) P_n^m(\cos\theta)$$

This equation can be expanded (in the form of a Taylor series expansion). This Taylor series will look as follows:

$$^{[5]} B_0 + 3 \text{ linear terms} + 5 \text{ 2}^{\text{nd}} \text{ order terms} + 7 \text{ 3}^{\text{rd}} \text{ order terms} + 9 \text{ 4}^{\text{th}} \text{ order.}$$

This is our magnetic field, and we want it to be as homogeneous as possible!

This is the distortion of the magnetic field in the x, y, and z-direction. By intentionally creating a field of the same amplitude but inverted sign (opposite direction), the field distortion is eliminated (i.e. we applied a first order shim).

This is the distortion of the magnetic field in the xy, zx, xy, z², and x²-y² direction. By intentionally creating a field of the same amplitude, but inverted sign (other direction), the field distortion in these directions is eliminated (i.e. we applied a second order shim).

The information in this document contains general descriptions of the technical options available, which do not always have to be present in individual cases. The required features should therefore be specified in each individual case at the time of closing the contract.

Siemens reserves the right to modify the design and specifications contained herein without prior notice. Please contact your local Siemens Sales representative for the most current information.

Note:
 Original images always lose a certain amount of detail when reproduced.

Siemens AG, Medical Solutions
 Magnetic Resonance
 Henkestr. 127, D-91054 Erlangen
 Germany
 Telephone: ++49 9131 84-0
 www.SiemensMedical.com

Siemens **Medical**
Solutions that help

Order No. A91100-M2220-A878-1-7600
 Printed in Germany
 CCA 63878 WS 09025.