

[www.usa.siemens.com/healthcare](http://www.usa.siemens.com/healthcare)

## Value-Based Purchasing Program

The Siemens Solution

### VBP Final Rule—May 2011

Effective July 1, 2011, CMS implemented a pay-for-quality system called the Value-Based Purchasing (VBP) program, which ties providers' inpatient Medicare payments to performance on a select group of quality and patient satisfaction metrics.

CMS proposed 12 process of care measures plus Hospital Consumer Assessment of Healthcare Providers and Systems surveys (HCAHPS) for the FY 2013 value-based purchasing program.

Twelve process of care measures are associated with clinical quality and eight categories of HCAHPS are associated with patient experience based on HCAHPS scores. Additional measures will be added in FY 2014 and beyond.

### Distribution of Funds

Beginning October 1, fiscal year 2012, the new Hospital VBP program will distribute Medicare funds to hospitals based on their performance on their overall VBP performance.

CMS plans for the VBP program to be budget neutral such that roughly half of hospitals will receive a bonus payment above and beyond the expected rate, while the other half will experience reduced payments.

The law sets the reduction at 1 percent of the overall Medicare market basket in FY 2013, rising to 2 percent by FY 2017.

### Siemens Solution

Our VBP Solution will assist hospitals in identifying the gaps in their current processes and technologies while directing the appropriate changes in order for them to optimize core delivery and performance metrics that have direct impact to their fiscal incentives payments from the VBP directive by CMS.

The program leverages Siemens' software and newly created content such as workflows, as well as complementing assessments and reports. It also includes workflow expertise, domain expertise, technology assessments, and people leadership.

This program will help hospitals improve quality, reduce costs, increase customer satisfaction, and improve their performance on the metrics associated with the VBP initiative.

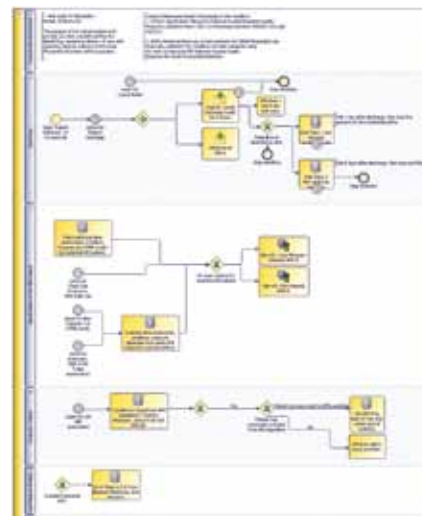

AMI Workflow

## VBP Offering

- Assess existing technologies and provide gap analysis on needs (new s/w, interface, etc.).
- Map care pathways for focused health conditions.
- Benchmark a provider's KPIs against national, state, and peer-to-peer data.
- Identify gaps by analyzing patient level data and physician performance, set goals for improvement.
- Plug and play/inject improvements back into care pathways (via Siemens Workflow Engine), optimize s/w assets, and/or Modality products.
- Monitor/assess outcomes and Improvements over time via modeling tools.

## VBP Deliverables

- 12 reports for clinical process of care measures.
- Interface to import HCAHPS data from third-party vendor into Siemens reporting tools.
- Workflows for the VBP "health categories" based on CMS care guidelines.
- Assessments to ensure compliance with VBP measures (e.g., checklist for HF-1 Discharge Instructions).

AMI Assessment

The outcomes achieved by the Siemens customers herein were achieved in the customer's unique setting. Since there is no "typical" hospital and many variables exist (e.g., hospital size, case mix, level of IT adoption), there can be no guarantee that others will achieve the same results.

On account of certain regional limitations of sales rights and service availability, we cannot guarantee that all products included in this brochure are available through the Siemens sales organization worldwide. Availability and packaging may vary by country and is subject to change without prior notice. Some/All of the features and products described herein may not be available in the United States.

The information in this document contains general technical descriptions of specifications and options as well as standard and optional features which do not always have to be present in individual cases.

Siemens reserves the right to modify the design, packaging, specifications and options described herein without prior notice. Please contact your local Siemens sales representative for the most current information.

Note: Any technical data contained in this document may vary within defined tolerances. Original images always lose a certain amount of detail when reproduced.

**To learn more about Siemens Value-Based Purchasing Solution, contact your Siemens representative or call 1-888-826-9702.**

### Global Siemens Headquarters

Siemens AG  
Wittelsbacherplatz 2  
80333 Muenchen  
Germany

### Global Siemens Healthcare Headquarters

Siemens AG  
Healthcare Sector  
Henkestrasse 127  
91052 Erlangen  
Germany  
Telephone: +49 9131 84-0  
www.siemens.com/healthcare

### Legal Manufacturer

Siemens AG  
Wittelsbacherplatz 2  
80333 Muenchen  
Germany

### Local Contact Information

Siemens Medical Solutions USA, Inc.  
51 Valley Stream Parkway  
Malvern, PA 19355-1406  
USA  
Telephone: +1-888-826-9702  
www.usa.siemens.com/healthcare

### Global Business Unit

Siemens Medical Solutions USA, Inc.  
Health Services  
51 Valley Stream Parkway  
Malvern, PA 19355-1406  
USA  
Telephone: +1-888-826-9702  
www.usa.siemens.com/healthcare

Order No. A9116-112395-C1-4A00

Printed in USA 10-2011 | All rights reserved  
© 2011 Siemens Medical Solutions USA, Inc.