

# SIEMENS

***AXIOM Artis***  
***VB22***



**AX**

## DICOM Conformance Statement

Rev. 03 30-Jun-2005

© Siemens AG Medical Solutions 2005  
All rights reserved

Siemens AG, Medical Solutions,  
Henkestr. 127, D-91050 Erlangen, Germany  
Siemensstr. 1, D-91301 Forchheim, Germany

Headquarters: Berlin and Munich  
Siemens AG, Wittelsbacher Platz 2, D-80333 Munich, Germany

Printed in the Federal Republic of Germany

*syngo* is a registered trademark of Siemens AG.

## Table of Contents

<b>1</b>	<b><i>Introduction</i></b> .....	<b>10</b>
1.1	Overview .....	10
1.2	Scope and Field.....	10
1.3	Audience .....	10
1.4	Remarks .....	10
1.5	Definitions, Terms and Abbreviations.....	11
1.6	References .....	11
1.7	Structure .....	11
<b>2</b>	<b><i>Implementation Model Verification</i></b> .....	<b>13</b>
2.1	Application Data Flow Diagram .....	13
2.2	Functional Definitions of Applications.....	13
2.3	Sequencing of Real-World Activities.....	13
<b>3</b>	<b><i>Application Entity Specification Verification</i></b> .....	<b>14</b>
3.1	<b>Verification AE Specification</b> .....	<b>14</b>
3.1.1	Association Establishment Policies .....	14
3.1.1.1	General .....	14
3.1.1.2	Number of Associations.....	14
3.1.1.3	Asynchronous Nature .....	14
3.1.1.4	Implementation Identifying Information .....	14
3.1.2	Association Initiation Policy .....	14
3.1.2.1	Associated Real-World Activity - Verification .....	14
3.1.3	Association Acceptance Policy .....	15
<b>4</b>	<b><i>Implementation Model Storage</i></b> .....	<b>16</b>
4.1	Application Data Flow Diagram .....	16
4.2	Functional Definitions of Application Entities.....	16
4.3	Sequencing of Real-World Activities.....	16
<b>5</b>	<b><i>Application Entity Specification Storage</i></b> .....	<b>17</b>
5.1	<b>Storage AEs Specification</b> .....	<b>17</b>
5.1.1	Association Establishment Policies .....	18
5.1.1.1	General .....	18
5.1.1.2	Number of Associations.....	18
5.1.1.3	Asynchronous Nature .....	18
5.1.1.4	Implementation Identifying Information .....	18
5.1.2	Association Initiation Policy .....	18
5.1.2.1	Associated Real-World Activity - Send.....	18
5.1.3	Association Acceptance Policy .....	22
5.1.3.1	Associated Real-World Activity - Receive .....	22
<b>6</b>	<b><i>Implementation Model Storage Commitment</i></b> .....	<b>27</b>

<b>6.1</b>	<b>Application Data Flow Diagram .....</b>	<b>27</b>
<b>6.2</b>	<b>Functional Definitions of Application Entities.....</b>	<b>27</b>
<b>6.3</b>	<b>Sequencing of real World Activities .....</b>	<b>27</b>
<b>7</b>	<b><i>AE Specification Storage Commitment .....</i></b>	<b>28</b>
<b>7.1</b>	<b>Storage Commitment AE Specification.....</b>	<b>28</b>
7.1.1	Association Establishment Policies .....	28
7.1.1.1	General.....	28
7.1.1.2	Number of Associations.....	28
7.1.1.3	Asynchronous Nature.....	28
7.1.1.4	Implementation Identifying Information .....	28
7.1.2	Association Initiation Policy .....	28
7.1.2.1	Real World Activity – Storage Commitment .....	29
<b>8</b>	<b><i>Implementation Model Query / Retrieve .....</i></b>	<b>31</b>
<b>8.1</b>	<b>Application Data Flow Diagram .....</b>	<b>31</b>
<b>8.2</b>	<b>Functional Definitions of Application Entities.....</b>	<b>32</b>
<b>8.3</b>	<b>Sequencing of Real-World Activities.....</b>	<b>32</b>
<b>9</b>	<b><i>Application Entity Specification Query/Retrieve.....</i></b>	<b>33</b>
<b>9.1</b>	<b>Query/Retrieve Service AEs Specification.....</b>	<b>33</b>
9.1.1	Association Establishment Policies .....	34
9.1.1.1	General.....	34
9.1.1.2	Number of Associations.....	34
9.1.1.3	Asynchronous Nature.....	34
9.1.1.4	Implementation Identifying Information .....	34
9.1.2	Association Initiation Policy .....	34
9.1.2.1	Real World Activity - Find SCU.....	34
9.1.2.2	Real-World Activity – Move SCU.....	37
9.1.3	Association Acceptance Policy .....	39
9.1.3.1	Real-World Activity - Find SCP.....	39
9.1.3.2	Real-World Activity - Get SCP.....	44
9.1.3.3	Real-World Activity - Move SCP.....	45
<b>10</b>	<b><i>Implementation Model Print.....</i></b>	<b>47</b>
<b>10.1</b>	<b>Application Data Flow Diagram .....</b>	<b>47</b>
<b>10.2</b>	<b>Functional Definition of Application Entities .....</b>	<b>47</b>
<b>10.3</b>	<b>Sequencing of Real-World Activities .....</b>	<b>47</b>
<b>11</b>	<b><i>Application Entity Specification Print.....</i></b>	<b>48</b>
<b>11.1</b>	<b>Print Management AE Specification .....</b>	<b>48</b>
11.1.1	Association Establishment Policies .....	48
11.1.1.1	General.....	48
11.1.1.2	Number of Associations.....	48
11.1.1.3	Asynchronous Nature.....	48
11.1.1.4	Implementation Identifying Information .....	49
11.1.2	Association Initiation Policy .....	49
11.1.2.1	Associated Real-World Activity.....	49
11.1.3	Association Acceptance Policy .....	54
<b>12</b>	<b><i>Implementation Model Worklist.....</i></b>	<b>55</b>
<b>12.1</b>	<b>Application Data Flow Diagram .....</b>	<b>55</b>

12.2	Functional Definitions of Application Entities .....	55
12.3	Sequencing of Real-World Activities .....	56
<b>13</b>	<b><i>Application Entity Specification Worklist.....</i></b>	<b>57</b>
13.1	Modality Worklist Service AE Specification .....	57
13.1.1	Association Establishment Policies .....	57
13.1.1.1	General.....	57
13.1.1.2	Number of Associations.....	57
13.1.1.3	Asynchronous Nature.....	57
13.1.1.4	Implementation Identifying Information .....	57
13.1.2	Association Initiation Policy .....	58
13.1.2.1	Real-World Activity .....	58
<b>14</b>	<b><i>Implementation Model MPPS.....</i></b>	<b>65</b>
14.1	Application Data Flow Diagram .....	65
14.2	Functional Definitions of Application Entities .....	65
14.3	Sequencing of real World Activities.....	65
<b>15</b>	<b><i>AE Specification MPPS .....</i></b>	<b>66</b>
15.1	Modality Performed Procedure Step AE Specification.....	66
15.1.1	Association Establishment Policies .....	66
15.1.1.1	General.....	66
15.1.1.2	Number of Associations.....	66
15.1.1.3	Asynchronous Nature.....	66
15.1.1.4	Implementation Identifying Information .....	66
15.1.2	Association Initiation Policy .....	66
15.1.2.1	Real World Activity .....	67
<b>16</b>	<b><i>Communication Profiles .....</i></b>	<b>72</b>
16.1	Supported Communication Stacks .....	72
16.1.1	TCP/IP Stack .....	72
16.1.1.1	API.....	72
16.1.1.2	Physical Media Support.....	72
<b>17</b>	<b><i>Extensions / Specializations / Privatizations .....</i></b>	<b>73</b>
17.1.1	Standard Extended / Specialized / Private SOPs.....	73
17.1.2	Private Transfer Syntaxes .....	73
<b>18</b>	<b><i>Configuration .....</i></b>	<b>74</b>
18.1	AE Title/Presentation Address Mapping.....	74
18.1.1	DICOM Verification .....	74
18.1.2	DICOM AE Titles.....	74
18.1.2.1	DICOM Storage AE Title .....	74
18.1.2.2	DICOM Query/Retrieve AE Title.....	74
18.1.2.3	DICOM Print AE Title.....	74
18.1.2.4	DICOM Modality Worklist AE Title.....	75
18.2	Configurable Parameters .....	75
18.2.1	Storage, Storage Commitment and Query/Retrieve.....	75
18.2.2	Print.....	76
18.2.3	Modality Worklist.....	76
18.3	Default Parameters .....	76
<b>19</b>	<b><i>Support of Extended Character Sets .....</i></b>	<b>78</b>
<b>20</b>	<b><i>AXIOM Artis VB22 Offline Media Application Profile.....</i></b>	<b>79</b>

<b>20.1</b>	<b>Class and Profile Identification .....</b>	<b>79</b>
<b>20.2</b>	<b>Clinical Context.....</b>	<b>79</b>
20.2.1	Roles and Service Class Options .....	79
20.2.1.1	File Set Creator .....	80
20.2.1.2	File Set Reader.....	80
20.2.1.3	File Set Updater.....	80
<b>20.3</b>	<b>PRI-XAMAS Profiles.....</b>	<b>81</b>
20.3.1	SOP Classes and Transfer Syntaxes .....	81
20.3.2	Physical Media and Formats .....	82
20.3.3	Directory Information in DICOMDIR .....	82
20.3.3.1	Basic Directory IOD Specialization Option .....	82
20.3.3.2	Additional Keys.....	83
20.3.3.3	Private Directory Record Keys .....	84
20.3.3.4	Icon Images .....	84
20.3.4	Other Parameters .....	84
20.3.4.1	Multi-Frame JPEG Format.....	84
20.3.4.2	Attribute Value Precedence.....	84
<b>21</b>	<b>Application Profile Conformance Statement.....</b>	<b>85</b>
<b>21.1</b>	<b>Introduction .....</b>	<b>85</b>
21.1.1	Purpose.....	85
21.1.2	Scope.....	85
21.1.3	Definitions, Abbreviations .....	85
21.1.3.1	Definitions.....	85
21.1.4	Abbreviations .....	85
21.1.5	References.....	86
21.1.6	Remarks.....	86
<b>21.2</b>	<b>Implementation Model.....</b>	<b>87</b>
21.2.1	Application Data Flow Diagram .....	87
21.2.2	Functional Definitions of AEs.....	87
21.2.3	Sequencing of Real-World Activities .....	87
21.2.4	File Meta Information Options.....	88
<b>21.3</b>	<b>AE Specifications.....</b>	<b>88</b>
21.3.1	DICOM Archive Specification .....	88
21.3.1.1	File Meta Information for the Application Entity.....	88
21.3.1.2	Real-World Activities for this Application Entity.....	88
<b>21.4</b>	<b>Augmented and Private Profiles.....</b>	<b>90</b>
21.4.1	Augmented Application Profiles.....	90
21.4.2	Private Application Profiles .....	90
21.4.2.1	PRI-XAMAS-CD .....	90
<b>21.5</b>	<b>Extensions, Specialization and Privatization of SOP Classes and Transfer Syntaxes .....</b>	<b>90</b>
21.5.1	SOP Specific Conformance Statement for Basic Directory.....	90
21.5.1.1	Extension, Specialization for SIEMENS Non-Image Objects.....	90
<b>21.6</b>	<b>Configuration .....</b>	<b>91</b>
21.6.1	AE Title Mapping .....	91
21.6.1.1	DICOM Media Storage AE Title.....	91
<b>21.7</b>	<b>Support of Extended Character Sets .....</b>	<b>91</b>
<b>Annex A: Additional Information .....</b>		<b>93</b>
<b>A.1</b>	<b>SIEMENS Private Non-Image IOD .....</b>	<b>93</b>
<b>A.2</b>	<b>Siemens Standard Extended Modules .....</b>	<b>97</b>

**A.3 Registry of private DICOM Data Elements ..... 106**

**A.4 Extended XA IOD..... 110**

**A.5 Private Non-Image IOD ..... 114**

**A.6 Quant Report Images ..... 115**

**A.7 CT/MR Image Converted to XA IOD ..... 118**

**A.8 Sorting Order AXIOM Artis VB22 ..... 123**

**A.9 DICOM Print SCU – detailed status displays ..... 129**

**Table of Tables**

Table 1	List of products applicable to this Conformance Statement	10
Table 2	Implementation Identifying Information	14
Table 3	Proposed Presentation Contexts	15
Table 4	Supported SOP Classes as an SCU	17
Table 5	Supported private SOP Classes as an SCU	17
Table 6	Supported SOP Classes as an SCP	17
Table 7	Supported private SOP Classes as an SCP	17
Table 8	Implementation Identifying Information	18
Table 9	Proposed Presentation Context – Send Images	19
Table 10	Resized images attributes	21
Table 11	Proposed Presentation Context – Receiving Images	23
Table 12	Attributes with applied defaults	24
Table 13	Storage Commitment SOP Class supported	28
Table 14	Implementation Identifying Information	28
Table 15	Proposed Presentation contents – request Storage Commitment	29
Table 16	Accepted Presentation contents – request Storage Commitment	30
Table 17	Supported SOP Classes as SCU	33
Table 18	Supported SOP Classes as SCP	33
Table 19	Implementation Identifying Information	34
Table 20	Proposed Presentation Contexts - Find SCU	35
Table 21	Search keys for Query models - Find SCU	37
Table 22	C-FIND response status	37
Table 23	Proposed Presentation Contexts - Move SCU “Import”	38
Table 24	Status Codes - Move SCU “Import”	38
Table 25	Accepted Presentation Contexts - Find SCP	39
Table 26	Supported Query attributes sorted by Query Level – Patient Root Information Model	41
Table 27	Supported Query attributes sorted by Query Level – Study Root Information Model	43
Table 28	Supported Query attributes sorted by Query Level – Patient/Study only Information Model	43
Table 29	Status Codes	43
Table 30	Accepted Presentation Contexts - Get SCP	44
Table 31	Status Codes	45
Table 32	Accepted Presentation Contexts - Move SCP	45
Table 33	Status Codes	46
Table 34	Basic Grayscale Print Management Meta SOP Class	48
Table 35	Implementation Identifying Information	49
Table 36	Proposed Presentation Contexts	50
Table 37	Used Basic Film Session N-CREATE-RQ attributes	51
Table 38	Attributes of N-DELETE-RQ on Basic Film Session SOP Class	51
Table 39	Basic Film Session SOP Status	51
Table 40	Used Film Box N-CREATE-RQ attributes	52
Table 41	Attributes of N-DELETE-RQ on Basic Film Session SOP Class	52
Table 42	Basic Film Session SOP Status	52
Table 43	Mandatory Basic Grayscale Image Box N-SET attributes	53
Table 44	Basic Grayscale Image Box SOP Status	53
Table 45	Used Printer N-EVENT report attributes	53
Table 46	Mandatory Printer N-GET-RSP, N-EVENT-RQ attributes	53
Table 47	Used Print Job N-EVENT Report attributes	54
Table 48	SOP Classes as a SCU	57
Table 49	Implementation Identifying Information	57
Table 50	Proposed Presentation Contexts	58
Table 51	Supported Broad Worklist Query Search Key Attributes	59
Table 52	Basic Worklist C-FIND-RSP Return Key Attributes	62
Table 53	Patient based "narrow query" Search Key Attributes	63
Table 54	C-FIND-RSP Status	64
Table 55	SOP Classes as an SCU	66
Table 56	Implementation Identifying Information	66

Table 57	<i>Proposed Presentation Contexts - MPPS</i>	67
Table 58	<i>Performed Procedure Step N-CREATE Attributes</i>	69
Table 59	<i>MPPS N-CREATE Response Status</i>	69
Table 60	<i>Performed Procedure Step N-SET Attributes</i>	70
Table 61	<i>MPPS N-SET Response Status</i>	71
Table 62	<i>Ready-processed configuration</i>	76
Table 63	<i>PRI-XAMAS Universal Angio/Radio Class Profile</i>	79
Table 64	<i>PRI-XAMAS SOP Classes and Transfer Syntaxes</i>	82
Table 65	<i>Abbreviations for Transfer Syntaxes</i>	82
Table 66	<i>PRI-XAMAS Additional DICOMDIR Keys</i>	83
Table 67	<i>PRI-XAMAS Additional PRIVATE Record Keys</i>	84
Table 68	<i>Siemens AXIOM Artis VB22 based products</i>	85
Table 69	<i>File Meta Information Options</i>	88
Table 70	<i>Application profiles, Activities, and Roles for DICOM Archive</i>	88
Table 71	<i>STD-GEN-CD Supported SOP Classes for FSR Role</i>	89
Table 72	<i>Extension, Specialization for SIEMENS Non-Image Objects</i>	90
Table 73	<i>SIEMENS Private Non-Image IOD</i>	93
Table 74	<i>CSA Non-Image IOD Modules</i>	95
Table 75	<i>CSA Non-Image Attributes</i>	96
Table 76	<i>CSA Image IOD Modules</i>	97
Table 77	<i>MEDCOM Header Modules</i>	99
Table 78	<i>MEDCOM History Information</i>	99
Table 79	<i>MEDCOM OOG Module</i>	99
Table 80	<i>Edge Enhancement Module</i>	100
Table 81	<i>Angio Viewing Module</i>	101
Table 82	<i>Angio Acquisition Data Module</i>	103
Table 83	<i>Angio Quantitation Module</i>	103
Table 84	<i>Original Image Info Module</i>	104
Table 85	<i>Image Type Extentions</i>	105
Table 86	<i>Private Elements in Group 0019</i>	106
Table 87	<i>Private Elements in Group 0021</i>	107
Table 88	<i>Private Elements in Group 0023</i>	107
Table 89	<i>Private Elements in Group 0025</i>	108
Table 90	<i>Private Elements in Group 0029 and 7FE1</i>	108
Table 91	<i>Overview of supplied attributes- X-Ray-Angiographic images (Original, Derived)</i>	113
Table 92	<i>Data Dictionary of private IOD Definition –Study-Report</i>	114
Table 93	<i>Overview of supplied attributes- X-Ray-Angiographic image (Quant Report Image)</i>	117
Table 94	<i>Overview of supplied attributes- XA image (Derived) from CT image</i>	120
Table 95	<i>Overview of supplied attributes- XA image (Derived) from MR image</i>	122
Table 96	<i>Identifications of images</i>	123
Table 97	<i>Identifications of Store Monitor images</i>	123
Table 98	<i>Identifications of Reference images</i>	124
Table 99	<i>Identifications of Quant report images</i>	124
Table 100	<i>Identifications of Exam Protocol non-images</i>	124
Table 101	<i>Printer Status Information</i>	133
Table 102	<i>Printer Status Information - Agfa</i>	133
Table 103	<i>Printer Status Information – Kodak (Imation)</i>	133
Table 104	<i>Printer Status Information – Kodak 190</i>	133
Table 105	<i>Printer Status Information – Kodak 2180/1120</i>	134
Table 106	<i>Printer Status Information – Codonics</i>	135
Table 107	<i>Additional DICOM Execution Status Infos</i>	135

## Table of Figures

Figure 1	Application Data Flow Diagram - Verification SCU/SCP	13
Figure 2	Application Data Flow Diagram – Storage SCU/SCP	16
Figure 3	Application Data Flow Diagram – Storage Commitment SCU	27
Figure 4	AXIOM Artis VB22 Application Data Flow Diagram – Query/Retrieve SCU	31
Figure 5	AXIOM Artis VB22 Application Data Flow Diagram – Query/Retrieve SCP	31
Figure 6	DICOM Application Data Flow Diagram – Print SCU	47
Figure 7	AXIOM Artis VB22 Application Flow Diagram – Basic Worklist SCU	55
Figure 8	AXIOM Artis VB22 Application Flow Diagram – MPPS SCU	65
Figure 9	Application Data Flow Diagram	87
Figure 10	DICOM Information Model	94
Figure 11	Image ordering – simple case	125
Figure 12	Image ordering – with reference images	126
Figure 13	Image ordering – with Store Monitor images	127
Figure 14	Image ordering – with Store Monitor and Quant images	128

# 1 Introduction

## 1.1 Overview

The Conformance Statement describes the DICOM interface for the Siemens AXIOM Artis VB22 in terms of part 2 of [DICOM].

This introduction describes the application's implemented DICOM functionality in general terms.

## 1.2 Scope and Field

The AXIOM Artis VB22 is a "syngo<sup>®</sup>-speaking<sup>an</sup>" Imaging Modality. The AXIOM Artis VB22 is designed to be integrated into an environment of medical DICOM-based devices. The AXIOM Artis VB22 DICOM network implementation acts as SCU and SCP for the DICOM Storage and Query/Retrieve services and as SCU for the DICOM Print, DICOM Basic Worklist, Storage Commitment and Modality Performed Procedure Step Services. Verification is supported in SCU (only via Service environment) and SCP role. Furthermore the handling of CD offline media is supported as a FSC, FSU and FSR.

Software Name	SIEMENS AXIOM Product
AXIOM Artis VB22	FC, FA, BC, BA, MP, TA, TC dFC, dFA, dBC, dBA, dMP, dTA, dTC

**Table 1 List of products applicable to this Conformance Statement**

## 1.3 Audience

This document is intended for hospital staff, health system integrators, software designers or implementers. It is assumed that the reader has a working understanding of DICOM.

## 1.4 Remarks

DICOM, by itself, does not guarantee interoperability. However, the Conformance Statement facilitates a first-level validation for interoperability between different applications supporting the same DICOM functionality as SCU and SCP, respectively.

This Conformance Statement is not intended to replace validation with other DICOM equipment to ensure proper exchange of information intended.

The scope of this Conformance Statement is to facilitate communication with Siemens and other vendors' Medical equipment. The Conformance Statement should be read and understood in conjunction with the DICOM 3.0 Standard [DICOM]. However, by itself it is not guaranteed to ensure the desired interoperability and a successful interconnectivity.

The user should be aware of the following important issues:

- The comparison of different conformance statements is the first step towards assessing interconnectivity between Siemens and non-Siemens equipment.
- Test procedures should be defined and tests should be performed by the user to validate the connectivity desired. DICOM itself and the conformance parts do not specify this.

---

<sup>a</sup> syngo is a registered trademark of Siemens AG

- The standard will evolve to meet the users' future requirements. Siemens is actively involved in developing the standard further and therefore reserves the right to make changes to its products or to discontinue its delivery.
- Siemens reserves the right to modify the design and specifications contained herein without prior notice. Please contact your local Siemens representative for the most recent product information.

## 1.5 Definitions, Terms and Abbreviations

Definitions, terms and abbreviations used in this document are defined within the different parts of the DICOM standard.

Additional Abbreviations and terms are as follows:

ACR	American College of Radiology
AE	DICOM Application Entity
ASCII	American Standard Code for Information Interchange
CSE	Customer Service Engineer
DB	Database
DCS	DICOM Conformance Statement
DICOM	Digital Imaging and Communications in Medicine
DIMSE	DICOM Message Service Element
DIMSE-C	DICOM Message Service Element with Composite Information Objects
DIMSE-N	DICOM Message Service Element with Normalized Information Objects
DSA	Digital Subtraction Angiography
IIDC	Image-Intensifier Distortion Correction
IOD	DICOM Information Object Definition
ISO	International Standard Organization
NEMA	National Electrical Manufacturers Association
O	Optional Key Attribute
PDU	DICOM Protocol Data Unit
R	Required Key Attribute
RIS	Radiology Information System
RWA	Real-World Activity
SCP	DICOM Service Class Provider (DICOM server)
SCU	DICOM Service Class User (DICOM client)
SOP	DICOM Service-Object Pair
U	Unique Key Attribute

## 1.6 References

[DICOM] Digital Imaging and Communications in Medicine (DICOM), NEMA PS 3.1-3.18, 2004

## 1.7 Structure

This Conformance Statement is subdivided into multiple Parts, which relate to individual documents needed to declare Conformance according to the requirements of "Part 2 - Conformance" of the DICOM Standard.

Those parts are:

- "Network Conformance Statement" for Network related Services
  - Storage - User/Provider (includes Verification - User/Provider)
  - Storage Commitment - User

- Query/Retrieve - User/Provider
- Basic Grayscale - User
- Basic Worklist - User
- Modality Performed Procedure Step - User
- A privately defined "Media Conformance Statement"
- "Offline Media Conformance Statement" to support local archive media.
- A general Appendix.

## 2 Implementation Model Verification

The AXIOM Artis VB22 DICOM Service Tool application requests Verification to verify the ability of a foreign DICOM application on a remote node to respond to DICOM messages.

Responding to Verification requests from remote nodes is handled by the Storage SCP application.

### 2.1 Application Data Flow Diagram

The AXIOM Artis VB22 DICOM network implementation acts as SCU and via the Storage SCP application as SCP for the C-ECHO DICOM network service. The product target Operating System is Windows XP.

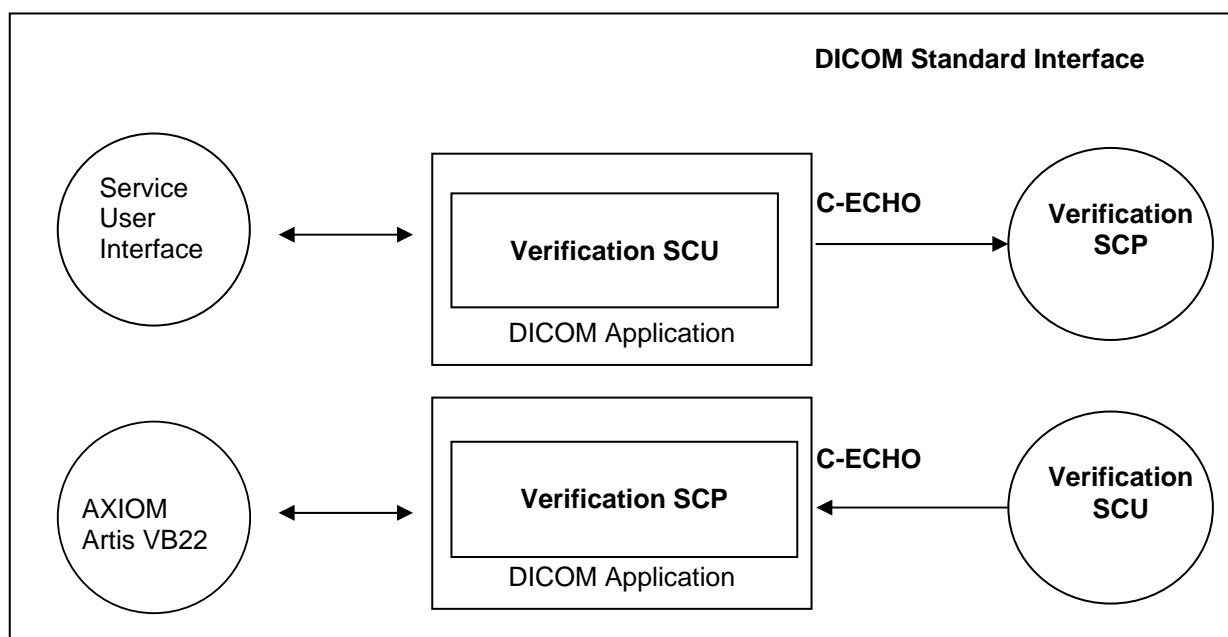

Figure 1 Application Data Flow Diagram - Verification SCU/SCP

### 2.2 Functional Definitions of Applications

The AXIOM Artis VB22 DICOM Service Tool application opens an association when a "verification" of a remote application is requested during a configuration session. This can be done when entering new data for remote application configuration or to verify existing configuration data.

### 2.3 Sequencing of Real-World Activities

Newly entered data have to be saved first, before a "verification" of these data is possible.

### **3 Application Entity Specification Verification**

#### **3.1 Verification AE Specification**

##### **3.1.1 Association Establishment Policies**

###### **3.1.1.1 General**

The AXIOM Artis VB22 DICOM Service Tool application attempts to open an association for verification request whenever the “verification” function is activated during network configuration of a remote DICOM application.

The AXIOM Artis VB22 DICOM application will accept association requests for verification.

###### **3.1.1.2 Number of Associations**

The AXIOM Artis VB22 DICOM Service Tool application initiates one association at a time to request verification.

The AXIOM Artis VB22 DICOM application is able to accept multiple associations at a time. It can handle up to 10 associations in parallel.

###### **3.1.1.3 Asynchronous Nature**

The AXIOM Artis VB22 DICOM software does not support asynchronous communication (multiple outstanding transactions over a single association).

###### **3.1.1.4 Implementation Identifying Information**

Implementation Class UID	1.3.12.2.1107.5.5.9.20000101
Implementation Version Name	SIEMENS_SWFVX47A

Table 2 Implementation Identifying Information

#### **3.1.2 Association Initiation Policy**

The AXIOM Artis VB22 DICOM Service Tool application attempts to initiate a new association for

- DIMSE C-ECHO service operations.

##### **3.1.2.1 Associated Real-World Activity - Verification**

###### **3.1.2.1.1 Associated Real-World Activity – Request Verification**

The associated Real-World activity is a C-ECHO request initiated by Service and Configuration SW environment whenever a “verification” is requested. If an association to a remote Application Entity is successfully established, Verification with the configured AET is

requested via the open association. If the C-ECHO Response from the remote Application contains a status other than "Success" this will be indicated in the service environment and the association is closed.

**3.1.2.1.2 Proposed Presentation Contexts**

The AXIOM Artis VB22 DICOM application will propose Presentation Contexts as shown in the following table:

Presentation Context Table – Verification SCU					
Abstract Syntax		Transfer Syntax		Role	Extended Negotiation
Name	UID	Name List	UID List		
Verification	1.2.840.10008.1.1	Implicit VR Little Endian	1.2.840.10008.1.2	SCU	None

Table 3 Proposed Presentation Contexts

**3.1.2.1.3 SOP Specific Conformance – Verification SCU**

The Application conforms to the definitions of the Verification SCU in accordance to the DICOM Standard.

**3.1.3 Association Acceptance Policy**

As mentioned above, the Verification SCP is part of the Storage SCP – see section 5.1.3.

## 4 Implementation Model Storage

The AXIOM Artis VB22 DICOM Application Entity both originates associations for Storage of DICOM Composite Information Objects in Remote Application Entities and accepts association requests for Storage from Remote Application Entities.

### 4.1 Application Data Flow Diagram

The AXIOM Artis VB22 DICOM network implementation acts as SCU and SCP for the C-STORE DICOM network service and as SCP for the C-ECHO DICOM network service. The product target Operating System is Windows XP.

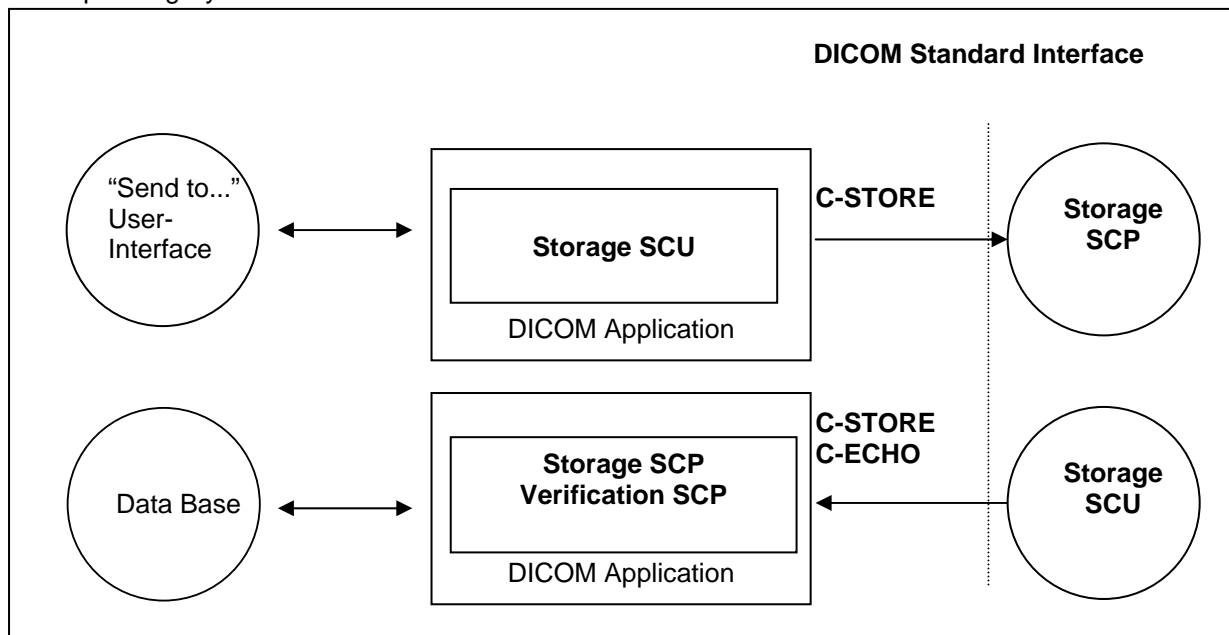

Figure 2 Application Data Flow Diagram – Storage SCU/SCP

### 4.2 Functional Definitions of Application Entities

The Storage SCU is invoked by the job control interface that is responsible for processing network archival tasks. The job consists of data describing the composite image objects selected for storage and the destination. An association is negotiated with the destination application entity and the image data is transferred using the C-STORE DIMSE-Service. Status of the transfer is reported to the job control interface.

The Storage SCP component of the AXIOM Artis VB22 DICOM application is operating as background server process. It is running when the machine is powered on and waits for Storage association requests. Upon accepting an association with a negotiated Presentation Context it starts to receive the Composite Image Objects and imports them to local database. Verification requests will be processed and responded by Storage SCP component, too.

### 4.3 Sequencing of Real-World Activities

not applicable

## 5 Application Entity Specification Storage

### 5.1 Storage AEs Specification

The AXIOM Artis VB22 Storage service class user/service class provider applications use one AE when initiating/receiving associations to/from remote DICOM nodes.

SIEMENS AXIOM Artis VB22 DICOM products provide Standard Conformance to the following DICOM SOP Classes as an SCU:

SOP Class Name	SOP Class UID
X-Ray Angiographic Image Storage	1.2.840.10008.5.1.4.1.1.12.1

Table 4 Supported SOP Classes as an SCU

SIEMENS AXIOM Artis VB22 DICOM products provide Private Conformance to the following DICOM V3.0 conform private SOP Classes as an SCU:

SOP Class Name	SOP Class UID
CSA Non-Image Storage	1.3.12.2.1107.5.9.1

Table 5 Supported private SOP Classes as an SCU

SIEMENS AXIOM Artis VB22 DICOM products provide Standard Conformance to the following DICOM V3.0 SOP Classes as an SCP:

SOP Class Name	SOP Class UID
Computed Tomography Image Storage	1.2.840.10008.5.1.4.1.1.2
Magnetic Resonance Image Storage	1.2.840.10008.5.1.4.1.1.4
X-Ray Angiographic Image Storage	1.2.840.10008.5.1.4.1.1.12.1
Verification	1.2.840.10008.1.1

Table 6 Supported SOP Classes as an SCP

SIEMENS AXIOM Artis VB22 DICOM products provide Private Conformance to the following DICOM-conform private SOP Classes as an SCP:

SOP Class Name	SOP Class UID
CSA Non-Image Storage	1.3.12.2.1107.5.9.1

Table 7 Supported private SOP Classes as an SCP

**5.1.1 Association Establishment Policies**

**5.1.1.1 General**

The existence of a job queue entry with network destination or an internal trigger from processing a retrieve request will activate the DICOM Storage Application. An association request is sent to the destination AE and upon successful negotiation of a Presentation Context the transfer is started.

The default PDU size used will be 256 KB.

**5.1.1.2 Number of Associations**

The AXIOM Artis VB22 DICOM application initiates several associations at a time, one for each destination to which a transfer request is being processed in the active job queue list.

The AXIOM Artis VB22 DICOM application is able to accept multiple associations at a time. It can handle up to 10 associations in parallel.

The number of Simultaneous DICOM associations can be configured via the Service-UI. The dialog can be found in Configuration / DICOM / General.

**5.1.1.3 Asynchronous Nature**

The AXIOM Artis VB22 DICOM software does not support asynchronous communication (multiple outstanding transactions over a single association).

**5.1.1.4 Implementation Identifying Information**

Implementation Class UID	1.3.12.2.1107.5.5.9.20000101
Implementation Version Name	"SIEMENS_SWFVX47A"

Table 8 Implementation Identifying Information

**5.1.2 Association Initiation Policy**

If a job with network destination gets active in the job list or a retrieve sub-operation is processed the AXIOM Artis VB22 DICOM application attempts to initiate a new association for

- DIMSE C-STORE service operations.

**5.1.2.1 Associated Real-World Activity - Send**

**5.1.2.1.1 Associated Real-World Activity – Send Image Objects to a Network Destination**

The associated Real-World activity is a C-STORE request initiated by an internal daemon process triggered by a job with network destination or the processing of an external C-MOVE

retrieve request. If the process successfully establishes an association to a remote Application Entity, it will transfer each image one after another via the open association. If the C-STORE Response from the remote Application contains a status other than "Success" or "Warning", the association is aborted.

**5.1.2.1.2 Proposed Presentation Context – Send Images**

The AXIOM Artis VB22 DICOM application will propose Presentation Contexts as shown in the following table:

Presentation Context Table					
Abstract Syntax		Transfer Syntax		Role	Ext. Neg.
Name	UID	Name List	UID List		
X-Ray Angiographic Image	1.2.840.10008.5.1.4.1.1.12.1	Implicit VR Little Endian Explicit VR Little Endian JPEG Lossless, Process 14 (selection value 1) JPEG Lossy Baseline (Process 1) JPEG Lossy Extended (Process 2 & 4) Explicit VR Big Endian	1.2.840.10008.1.2 1.2.840.10008.1.2.1 1.2.840.10008.1.2.4.70  1.2.840.10008.1.2.4.50  1.2.840.10008.1.2.4.51  1.2.840.10008.1.2.2	SCU	None
CSA Non-Image	1.3.12.2.1107.5.9.1	Implicit VR Little Endian Explicit VR Little Endian Explicit VR Big Endian	1.2.840.10008.1.2 1.2.840.10008.1.2.1 1.2.840.10008.1.2.2	SCU	None

Table 9 Proposed Presentation Context – Send Images

**5.1.2.1.3 SOP specific Conformance to Storage SOP classes**

The AXIOM Artis VB22 application will create XA IOD type images from image acquisition and post processing applications. Furthermore a private "Non-Image IOD" will be used to store numerical data and textual report results (e.g. Study Report). The XA IOD will be a "Standard Extended XA Storage" SOP Class. For certain imported/received IOD Types a conversion to a new XA image will be performed in order to enable viewing of those Instances on the AXIOM Artis based System.

The AXIOM Artis VB22 (DICOM) application will not change private attributes as long as no modification is done. During a "Store Monitor" or "Store Reference Image" operation all private attributes not defined within the AXIOM Artis VB22 DICOM application will be removed when the new object instance is created.

For association and DIMSE level time-outs, please refer to Configuration section of this document.

**5.1.2.1.3.1 Optional Attributes**

Data Dictionary of DICOM Type 2 and 3 IOD Attributes (CHECK correct Link below)

Please see the related Image Object definition tables in the Annex A.4 for a list of all DICOM IOD attributes of type 2 and 3, which are encoded by the AXIOM Artis VB22 applications.

**5.1.2.1.3.2 Specialized Information Object Definitions**

The DICOM images created by AXIOM Artis VB22 DICOM application conform to the DICOM IOD definitions (Standard extended IODs). But they will contain additional private elements, which have to be discarded by a DICOM system when modifying the image.

The DICOM nodes are responsible for data consistency when modifying images. All unknown private attributes have to be removed upon modification!

#### 5.1.2.1.3.3 Data Dictionary of applied private IOD Attributes

Please see "A.2" in the Annex for a list of possible private IOD attributes.

#### 5.1.2.1.3.4 Image Pixel Attribute Description for Grayscale Images

The Siemens AXIOM Artis DICOM application supports the Monochrome2 Photometric Interpretation with the unsigned integer 16 bit grayscale pixel and graphic overlay format. The lower 12 bits are used for pixel and the higher 4 bits are used for the graphic overlay:

##### **Pixel plane**

- samples per pixel (attribute 0028, 0002) = 1
- photometric interpretation (attribute 0028,0004) = "MONOCHROME2"
- pixel representation (attribute 0028, 0103) = 0
- bits allocated (attribute 0028, 0100) = 8, 16
- bits stored (attribute 0028,0101) = 8, 10, 12
- high bit (attribute 0028,0102) = 7, 9, 11

##### **Overlay plane**

- overlay type (attribute 60xx, 0040) = "G"
- bits allocated (attribute 60xx, 0100) = 1
- bit position (attribute 60xx, 0102) = 0
- overlay data (attribute 60xx, 3000) = supported (with "bits allocated = 8")

#### 5.1.2.1.3.5 Private Information Object Definitions

To fulfill all application requirements the AXIOM Artis DICOM implementation will use private IODs to store Data currently not defined in the DICOM Standard according to the DICOM information model. The privately defined IOD will contain all references to identify the Patient/Study/Series/Images to which the related information is belonging to.

This private Information will include

- CARE Graph
- Complete Study Report

All IOD used to store this private Information will be based on various Instances of the SIEMENS Non-Image IOD. Please see A.1 SIEMENS Private Non-Image IOD and A.5 Private Non-Image IOD in the Appendix for a detailed overview of the private IOD definition and the IOD tables for value encoding.

#### 5.1.2.1.4 Associated Real-World Activity - Send Image Objects resized to a Network destination

In Local Service it is possible to configure each individual DICOM node (Store SCP) to receive Artis images resized to 512x512 or 1024x1024 matrix depending on image type, e.g. card

images. The images in this case are "pre-processed" to be compliant to the Basic Cardiac Image definitions (512<sup>2</sup> Matrix with 8-Bits allocated).

**5.1.2.1.5 Proposed Presentation Contexts for resized images**

The proposed Presentation Contexts for resized images are identical to those described in section 5.1.2.1.2 Proposed Presentation Context – Send Images.

**5.1.2.1.6 SOP Specific Conformance for resized images**

The AXIOM Artis System itself will create XA IOD type images from image acquisition and post processing applications. Furthermore a private "Non-Image IOD" will be used to store numerical data and textual report results (e.g. Study Report). The XA IOD will be a "Standard Extended XA Storage" SOP Class. Please see the Appendix for detailed descriptions.

Downsized images will allow conversion of any image that is displayed in the AXIOM Artis viewing application to an image that conforms to the Basic Cardiac format. Conversion is limited to reduction of Matrix Size and Pixel Depth and is restricted to be applied to "image-type" instances only. The converted image is a temporary copy and therefore a new Instance UID is generated.

Quant Report images are by nature 1024x1024 and will not be resized and are sent "as they are".

The SOP Instance UID of the converted images will be created in a reproducible way by appending a "512" to the original UID.

The conversion will generate a Pixel Matrix output that is described by the following Attribute values:

Tag	DICOM Attribute	Attribute value (Resized 512)
[0028,0010]	Rows	512
[0028,0011]	Columns	512
[0028,0100]	Bits allocated	8
[0028,0101]	Bits Stored	8
[0028,0102]	High Bit	7

**Table 10 Resized images attributes**

In order to preserve integrity of the data with respect to the original Matrix Size and Pixel Depth, the following attributes will be adapted accordingly for the resulting image:

- [0018,1602] Shutter Left Vertical Edge
- [0018,1604] Shutter Right Vertical Edge
- [0018,1606] Shutter Upper Horizontal Edge
- [0018,1608] Shutter Lower Horizontal Edge
- [0018,1610] Center of Circular Shutter
- [0018,1612] Radius of Circular Shutter
- [0018,1702] Collimator Left Vertical Edge
- [0018,1704] Collimator Right Vertical Edge

- [0018,1706] Collimator Upper Horizontal Edge
- [0018,1708] Collimator Lower Horizontal Edge
- [0018,1710] Center of Circular Collimator
- [0018,1712] Radius of Circular Collimator
- [0018,1720] Vertices of the Polygonal Collimator
- [0018,1164] Imager Pixel Spacing
- [0028,1050] Window Center
- [0028,1051] Window Width
- [0028,3002] MOD LUT Descriptor
- [0028,3006] MOD LUT Data
- [6000,0010] Overlay Rows
- [6000,0011] Overlay Columns
- [6000,3000] Overlay Data
- private data attributes

### **5.1.3 Association Acceptance Policy**

The AXIOM Artis VB22 DICOM application attempts to accept a new association for

- DIMSE C-ECHO
- DIMSE C-STORE

service operations. Any Information Objects transmitted on that association will be checked on conformance and stored in database if check was successful.

#### **5.1.3.1 Associated Real-World Activity - Receive**

##### **5.1.3.1.1 Associated Real-World Activity – Receiving Images from a Remote Node**

The daemon receiving process will accept an association and will receive any images transmitted on that association and will store the images on disk in the own database if the conformance check is performed successfully.

##### **5.1.3.1.2 Accepted Presentation Context – Receiving Images**

The AXIOM Artis DICOM storage provider will only accept MONOCHROME<sub>x</sub> encoded images.

Color encoded images (RGB or Palette Color) are not supported.

The AXIOM Artis VB22 DICOM application will accept Presentation Contexts as shown in the following table:

Presentation Context Table					
Abstract Syntax		Transfer Syntax		Role	Ext. Neg.
Name	UID	Name List	UID List		
Computed Tomography Image	1.2.840.10008.5.1.4.1.1.2	Implicit VR Little Endian Explicit VR Little Endian JPEG Lossless, Process 14 (selection value 1) JPEG Lossy Baseline (Process 1) *1 JPEG Lossy Extended *1 (Process 2 & 4) Explicit VR Big Endian	1.2.840.10008.1.2 1.2.840.10008.1.2.1 1.2.840.10008.1.2.4.70  1.2.840.10008.1.2.4.50  1.2.840.10008.1.2.4.51  1.2.840.10008.1.2.2	SCP	None
Magnetic Resonance Image	1.2.840.10008.5.1.4.1.1.4	Implicit VR Little Endian Explicit VR Little Endian JPEG Lossless, Process 14 (selection value 1) JPEG Lossy Baseline (Process 1) *1 JPEG Lossy Extended *1 (Process 2 & 4) Explicit VR Big Endian	1.2.840.10008.1.2 1.2.840.10008.1.2.1 1.2.840.10008.1.2.4.70  1.2.840.10008.1.2.4.50  1.2.840.10008.1.2.4.51  1.2.840.10008.1.2.2	SCP	None
X-Ray Angiographic Image	1.2.840.10008.5.1.4.1.1.12.1	Implicit VR Little Endian Explicit VR Little Endian JPEG Lossless, Process 14 (selection value 1) JPEG Lossy Baseline (Process 1) *1 JPEG Lossy Extended *1 (Process 2 & 4) Explicit VR Big Endian	1.2.840.10008.1.2 1.2.840.10008.1.2.1 1.2.840.10008.1.2.4.70  1.2.840.10008.1.2.4.50  1.2.840.10008.1.2.4.51  1.2.840.10008.1.2.2	SCP	None
CSA Non-Image Storage	1.3.12.2.1107.5.9.1	Implicit VR Little Endian Explicit VR Big Endian Explicit VR Little Endian	1.2.840.10008.1.2 1.2.840.10008.1.2.2 1.2.840.10008.1.2.1	SCP	None
Verification	1.2.840.10008.1.1	Implicit VR Little Endian Explicit VR Big Endian Explicit VR Little Endian	1.2.840.10008.1.2 1.2.840.10008.1.2.2 1.2.840.10008.1.2.1	SCP	None

**Table 11 Proposed Presentation Context – Receiving Images**

**5.1.3.1.3 SOP-specific Conformance Statement – Receiving Images**

The AXIOM Artis VB22 DICOM application conforms to the Full Storage Class at Level 2.

Upon successfully receiving a C-STORE-RQ, the Siemens AXIOM Artis VB22 DICOM receiver performs a plausibility test on the received image and checks the availability of system resources. In the event of a successful C-STORE operation, the image has successfully been written on disk in the Siemens AXIOM Artis image format. For Private Attributes of VR=SQ only a nesting level of one is supported. This means that Private Sequences containing another Sequence will be removed from the image header during Storage.

The AXIOM Artis VB22 DICOM application returns the status SUCCESS upon successful operation, otherwise one of the following status codes is returned and the association is aborted:

- **Refused (A700):**  
This error status indicates a lack of Resources (e.g. not enough disk space) on the AXIOM Artis VB22 modality.
- **Invalid Dataset (0xA900 or 0xC000):**  
An error occurred while processing the image which makes it impossible to proceed. The image will not be stored and the association is aborted. The dataset may not contain one of

the Attributes “Study Instance UID”, “Series Instance UID” or “SOP Instance UID”, or one of them might have an invalid value.

- Processing Error (0110):  
An error occurred while processing the image, which makes it impossible to proceed.

**Attention!** Only after sending the response, the image will be saved into the database. If during this operation an error occurs, the association will be aborted. This implies that a C-STORE-RSP with status SUCCESS does not mean that the image was successfully stored into the database.

If an image instance is received that is identified by a SOP Instance UID which is already used by an Instance stored in database then the actual received image will be discarded. The existing Instance is not superseded.

### 5.1.3.1.3.1 Optional Attributes acceptance criterion - applied defaults

Upon receiving IOD other than created by the AXIOM Artis DICOM application a check for conformity is done and with successful completion the IOD is accepted for storage. Hereby defaults will be set when optional attributes are encountered with "no value" coding. Please see the following tables for details.

Attribute Name	Tag	Default Value
Window Center	[0028,1050]	Open window, e.g. bits stored=12 -> window center=2048
Window Width	[0028,1051]	Open window, e.g. bits stored=12 -> window width=4095

Table 12 Attributes with applied defaults

The following sections will differentiate the attribute contents required for Image Viewing. The AXIOM Artis VB22 DICOM application supports more formats for Storage of Images than Viewing.

### 5.1.3.1.3.2 Image Pixel Attribute Acceptance Criterion for Grayscale Images - Viewing

The AXIOM Artis VB22 Viewing application accepts the MONOCHROME2 photometric interpretation pixel format and graphic overlay with unsigned integer and 8 or 16 bits allocated. Accepted values:

- Pixel plane
  - samples per pixel (attribute 0028, 0002) = 1
  - photometric interpretation (attribute 0028,0004) = “MONOCHROME2”
  - pixel representation (attribute 0028, 0103) = 0
  - bits allocated (attribute 0028, 0100) = 8, 16
  - bits stored (attribute 0028,0101) = 8, 10, 12
  - high bit (attribute 0028,0102) = 7, 9, 11
  - only aspect ratio 1:1 is supported
  - number of rows (0028,0010) and columns (0028,0011) = 512 or 1024
- Overlay plane
  - overlay type (attribute 60xx, 0040) = “G”
  - bits allocated (attribute 60xx, 0100) = 16

- bit position (attribute 60xx, 0102) = 12, 13, 14, 15 (only bits above high bit permitted)
- Graphic Overlay will be shifted to fill Overlay Planes from Bit 12 and consecutive.
- Overlay plane
  - overlay type (attribute 60xx, 0040) = "G"
  - bits allocated (attribute 60xx, 0100) = 1
  - bit position (attribute 60xx, 0102) = 0
  - overlay data (attribute 60xx, 3000) = supported

Only Rectangular and Circular Shutter Shape is supported in this version. Images containing other Shutter Shapes will be displayed w/o shutter.

With multi-frame images the Overlay Graphic is only supported as replication of the 1<sup>st</sup> frame's overlay data.

#### 5.1.3.1.4 Presentation Context Acceptance Criterion

The AXIOM Artis VB22 DICOM application will accept any number of verification or storage SOP classes that are listed above. The number of presentation contexts accepted is limited to the maximum of 127 (DICOM limit). In the event that the AXIOM Artis VB22 DICOM application runs out of resources, it will reject the association request.

#### 5.1.3.1.5 Transfer Syntax Selection Policies

The AXIOM Artis VB22 DICOM application currently supports

- the Implicit VR Little Endian, the Explicit VR Little Endian and Explicit VR Big Endian Transfer Syntaxes
- the JPEG Lossless Non-hierarchical Transfer Syntax
- the JPEG Baseline and JPEG Extended Transfer Syntaxes (JPEG Lossy).

Any proposed presentation context including one of these Transfer Syntaxes will be accepted. Any proposed presentation context that does not include one of these Transfer Syntaxes will be rejected.

The order of preference in accepting Transfer Syntaxes within Presentation Contexts or Presentation Contexts with single Transfer Syntaxes is:

1. JPEG Lossy Extended
2. JPEG Lossless non-hierarchical
3. JPEG Lossy Baseline
4. Explicit VR Little Endian
5. Explicit VR Big Endian
6. Implicit VR Little Endian

With Implicit VR Little Endian Transfer Syntax the AXIOM Artis VB22 DICOM application will remove any Private Attributes not known to the application. Decision on removal of a Private Element is done if there is NO entry in the attribute-dictionary of the AXIOM Artis VB22 DICOM application.

Therefore any Explicit VR Transfer Syntax shall preferably be used by the Storage SCUs when sending Composite Image Instances to the AXIOM Artis VB22 DICOM application.

## 6 Implementation Model Storage Commitment

The Storage Commitment service class defines an application-level class of service which facilitates the commitment to storage. It performs an additional task of commitment of composite objects apart from the network based storage of images as defined by the Storage Service class. The AXIOM Artis VB22 DICOM implementation supports the Storage Commitment Push Model as SCU.

### 6.1 Application Data Flow Diagram

The AXIOM Artis VB22 DICOM network implementation acts as SCU for the Storage Commitment Push Model Service using the Storage Commitment Service Class. The product target Operating System is Windows XP.

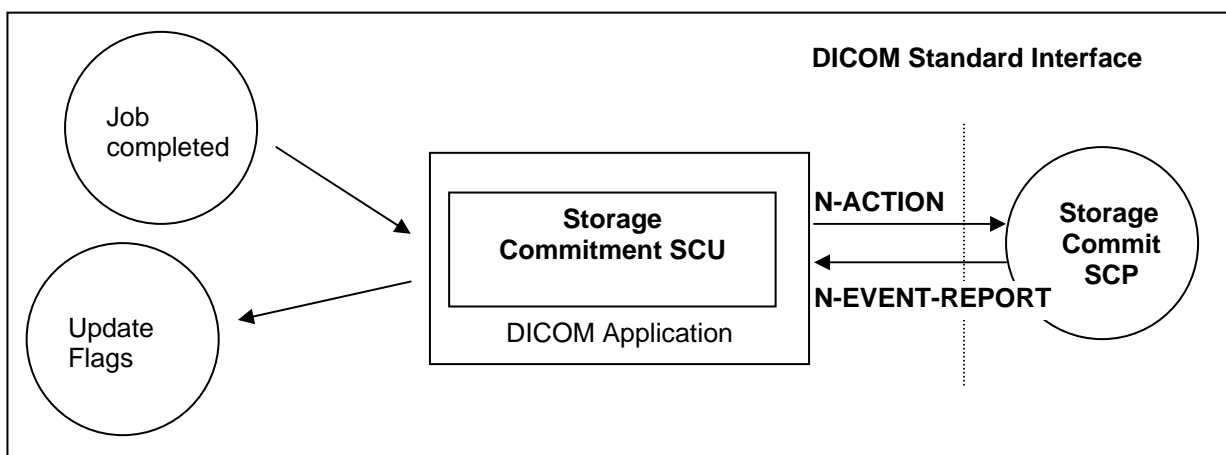

Figure 3 Application Data Flow Diagram – Storage Commitment SCU

### 6.2 Functional Definitions of Application Entities

With each successfully completed send job, the AXIOM Artis VB22 DICOM Application will create a Storage Commitment Push Model Identifier from the SOP Instances sent. Then a Storage Commit Request is triggered. Depending on configuration, the AXIOM Artis VB22 DICOM application will keep the association open for responses with a configurable time-out, or closes the association and expects responses on a different association that has to be established by the remote Storage Commitment SCP.

The commitment status derived from the related trigger response will be indicated in the related Status Flags of the related entity. It is possible to create triggers (“auto rules”) from this event.

The Transaction UIDs of the pending commitment request are kept “open” for a configurable amount in time (default: 1h). If the “open time” for a pending commitment request has elapsed w/o a related response from the provider, the Transaction UID is removed and the related entities are indicated as “commit failed”.

In any case, commitment will only be requested for previously and successfully sent images.

### 6.3 Sequencing of real World Activities

The Storage Commitment trigger is automatically derived from the successful completion of a Send Job.

## 7 AE Specification Storage Commitment

### 7.1 Storage Commitment AE Specification

SIEMENS AXIOM Artis VB22 DICOM application provides Standard Conformance to the following DICOMV3.0 SOP Class as an SCU:

SOP Class Name	SOP Class UID
Storage Commitment Push Model	1.2.840.10008.1.20.1

Table 13 Storage Commitment SOP Class supported

#### 7.1.1 Association Establishment Policies

##### 7.1.1.1 General

With a Send Job successfully completed, the DICOM application will generate an Storage Commitment Identifier which references to all Instances of the processed job. The Commit Request is then sent over a single opened association. The AXIOM Artis VB22 will wait for Status responses of the Storage Commitment Request. If the Provider accepts the Storage Commitment with Success Status, the generated Transaction UID, together with study identification data and a time-stamp, is kept. Depending on configuration, the association is closed when the configured time-out has elapsed or a response was received before. If the association is closed before a response was received, the response is then expected on a different association. Multiple Storage Commitment Requests can be pending.

The default PDU size used will be 256 KB.

##### 7.1.1.2 Number of Associations

The AXIOM Artis VB22 DICOM application initiates several associations at a time, one for each storage commitment request being processed.

##### 7.1.1.3 Asynchronous Nature

The AXIOM Artis VB22 DICOM software does not support asynchronous communication (multiple outstanding transactions over a single association).

##### 7.1.1.4 Implementation Identifying Information

Implementation Class UID	1.3.12.2.1107.5.5.9.20000101
Implementation Version Name	SIEMENS_SWFVX47A

Table 14 Implementation Identifying Information

#### 7.1.2 Association Initiation Policy

The AXIOM Artis VB22 DICOM Application Entity acts as a Service Class User (SCU) for the

- Storage Commitment Push Model Service Class (to request commitment for storage of instances previously sent).  
To do so, the AXIOM Artis VB22 will issue a
- N-ACTION DIMSE to request commitment or a

**7.1.2.1 Real World Activity – Storage Commitment**

**7.1.2.1.1 Associated Real-World Activity - Job Completed**

The AXIOM Artis VB22 Storage Commitment application sends the commit request (N-ACTION-RQ) message and waits for acceptance of this request (N-ACTION-RSP). After receiving this, the transaction is marked as “waiting”.

Depending on a configuration value, the association will then be closed or kept open. In the first case, there is another configurable timeout giving the number of hours (h) and minutes (m) (by default 1h:0m) to wait for the corresponding commit response (N-EVENT-REPORT). In the second case, this time is the (also configurable) time-out for the association. For both cases, if the commit response (N-EVENT-REPORT) does not arrive during the configured time, the transaction will be marked as failed. The AXIOM Artis VB22 does not resend objects from a failed Storage Commitment result in any case.

If the commit response (N-EVENT-REPORT) received has the status of “complete - failure exists”, the transaction is marked as failed, else the transaction is marked as “completed”; In both cases, a message is shown to the user.

**7.1.2.1.2 Proposed Presentation Contexts - Job Completed**

The AXIOM Artis VB22 DICOM application will propose Presentation Contexts as shown in the following table:

Presentation Context Table					
Abstract Syntax		Transfer Syntax		Role	Ext. Neg.
Name	UID	Name List	UID List		
Storage Commitment Push Model	1.2.840.10008.1.20.1	Implicit VR Little Endian Explicit VR Little Endian Explicit VR Big Endian	1.2.840.10008.1.2 1.2.840.10008.1.2.1 1.2.840.10008.1.2.2	SCU	None

Table 15 Proposed Presentation contents – request Storage Commitment

**7.1.2.1.3 SOP Specific Conformance Statement- Job Completed**

Storage Commitment is supported for all the SOP class UIDs mentioned in Chapter 5.1.3.1.2.

The Referenced Study Component Sequence is not supported.

Storage Media File-Set ID and UID Attributes will not be supported in the commitment request (N-ACTION primitive) invoked by the Storage Commitment SCU.

**7.1.2.1.4 Associated Real-World Activity - Update Flags**

The AXIOM Artis VB22 Storage Commitment DICOM Application has sent a Storage Commitment Request and, being configured to receive response on a separate association, has closed the association, and now it gets an association request from the Storage Commitment SCP that want to send the results. The AXIOM Artis VB22 DICOM application will await Storage

commitment Notification triggers. Any incoming Notification will be checked for validity, that is, if the related Transaction UID is still part of the Pending Request Queue.

If the Notification is valid, the Notification Event Information is evaluated and the related Instances marked with the related status. The over-all Commit Status of the higher Information Entities is derived from propagation of the States of all Image entities included in a study.

The Status Flags directly affected by Storage Commitment results and indicated in the different entities of the Patient Browser list can be one of

- “AC” or “SC” - Successful Commitment, A means archived to configured Archive destination, whereas S means sent to any other destination
- “AF” or “SF” - Commitment failed.
- “A?” or “S?” - Commitment request is sent, response is pending.

In case of failure the user has to repeat the transfer of images to the Archive destination. Another Storage Commitment will be performed after sending is completed successfully.

**7.1.2.1.5 Accepted Presentation Contexts - Update Flags**

The Siemens AXIOM Artis VB22 DICOM application will accept Presentation Contexts as shown in the following table:

Presentation Context Table					
Abstract Syntax		Transfer Syntax		Role	Ext. Neg.
Name	UID	Name List	UID List		
Storage Commitment Push Model	1.2.840.10008.1.20.1	Implicit VR Little Endian Explicit VR Little Endian Explicit VR Big Endian	1.2.840.10008.1.2 1.2.840.10008.1.2.1 1.2.840.10008.1.2.2	SCU	None

Table 16 Accepted Presentation contents – request Storage Commitment

**7.1.2.1.6 SOP-specific Conformance Statement - Update Flags**

If the Commitment response (N-EVENT-REPORT) received has the status of “complete - failure exists”, the transaction is marked as failed, else the transaction is marked as “completed”; In both cases, a message is shown to the user.

The related status flags are set for the committed images in the local database.

For images sent in resized format, the flag will be set for the original images still available on the system.

The AXIOM Artis VB22 DICOM application will NOT support the Storage Media File Set ID attributes.

## 8 Implementation Model Query / Retrieve

The query/retrieve service class defines an application-level class of services which facilitates the management of images and patient data against the well-defined information model of DICOM and allows a DICOM AE to retrieve images from a remote DICOM node or to request a remote DICOM AE to initiate a transfer of images to another DICOM AE. The AXIOM Artis VB22 DICOM query/retrieve application supports the query/retrieve services to act as SCU and SCP.

### 8.1 Application Data Flow Diagram

The AXIOM Artis VB22 DICOM network implementation acts as SCU and SCP for the query/retrieve network service. The product target Operating System is Windows XP.

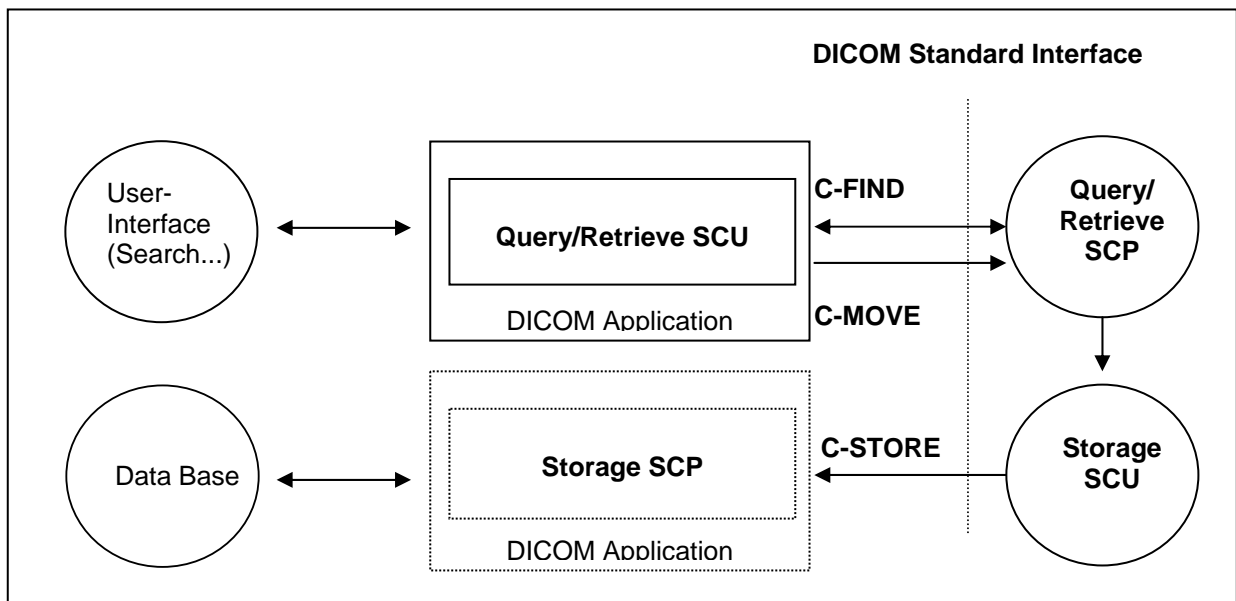

Figure 4 AXIOM Artis VB22 Application Data Flow Diagram – Query/Retrieve SCU

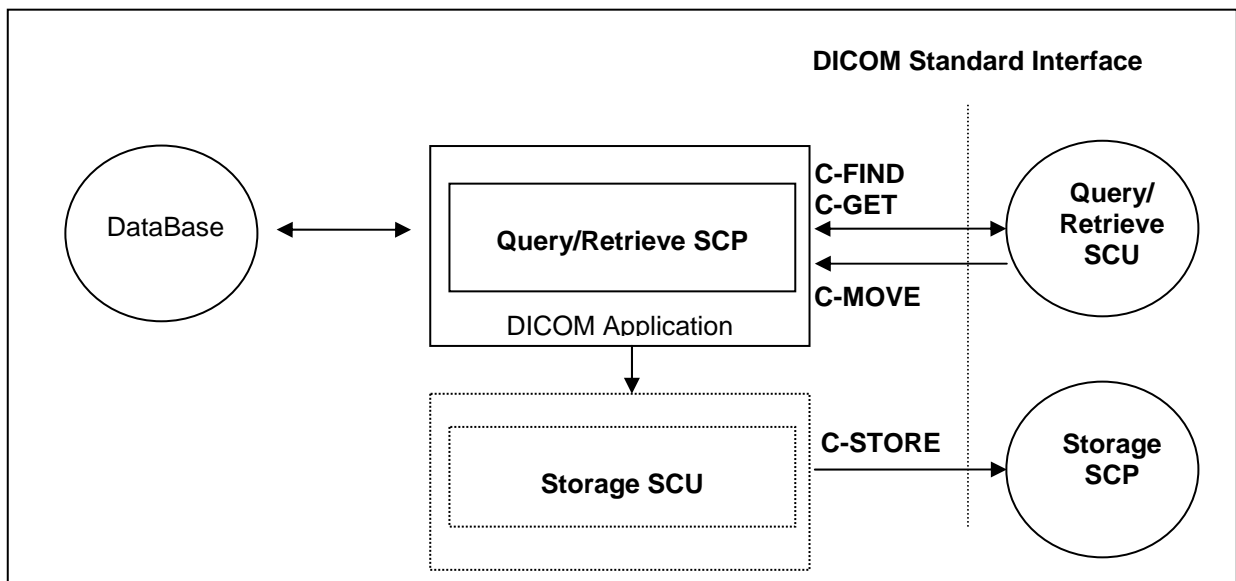

Figure 5 AXIOM Artis VB22 Application Data Flow Diagram – Query/Retrieve SCP

## **8.2 Functional Definitions of Application Entities**

The AXIOM Artis VB22 DICOM Query/Retrieve SCU requests the remote query/retrieve SCP to perform a search and match to the keys specified in the request in order to display the results in the AXIOM Artis VB22 user interface. Depending on user action (Import) the AXIOM Artis VB22 DICOM SCU sends a C-MOVE DIMSE service to initiate a C-STORE sub-operation on the SCP to start an image transfer from remote Storage SCU (running on Query/Retrieve SCP) to the AXIOM Artis VB22 Storage SCP.

The AXIOM Artis VB22 DICOM query/retrieve SCP responds to C-FIND DIMSE services from remote SCU applications. Depending on further remote request, a C-GET or a C-MOVE involves the AXIOM Artis VB22 DICOM query/retrieve SCP application to initiate a C-STORE association (by triggering the own Storage SCU) to send image objects to a remote Storage SCP.

All components of the DICOM query/retrieve SCP application are operating as background server processes. They are running when the machine is powered on and respond to queries based on the records stored in the database.

## **8.3 Sequencing of Real-World Activities**

Retrieve of images is only possible if results from a previous "Search..." operation are available and those entities can be selected for "Import".

## 9 Application Entity Specification Query/Retrieve

### 9.1 Query/Retrieve Service AEs Specification

The Query/Retrieve SCU requests that the remote SCP performs a match of all keys specified in the request, against the information in its database and the identified images will be moved over a different (C-MOVE) storage association.

The Query/Retrieve SCP responds to queries based on the records based on its database and images will be sent to the requesting SCU or to a different storage destination.

SIEMENS AXIOM Artis VB22 DICOM products provide Standard Conformance to the following DICOM V3.0 SOP Classes as SCU:

SOP Class Name	SOP Class UID
Patient Root Query/Retrieve Information Model - FIND	1.2.840.10008.5.1.4.1.2.1.1
Patient Root Query/Retrieve Information Model - MOVE	1.2.840.10008.5.1.4.1.2.1.2
Study Root Query/Retrieve Information Model - FIND	1.2.840.10008.5.1.4.1.2.2.1
Study Root Query/Retrieve Information Model - MOVE	1.2.840.10008.5.1.4.1.2.2.2

Table 17 Supported SOP Classes as SCU

SIEMENS AXIOM Artis VB22 DICOM products provide Standard Conformance to the following DICOM V3.0 SOP Classes as an SCP:

SOP Class Name	SOP Class UID
Patient Root Query/Retrieve Information Model - FIND	1.2.840.10008.5.1.4.1.2.1.1
Patient Root Query/Retrieve Information Model - MOVE	1.2.840.10008.5.1.4.1.2.1.2
Patient Root Query/Retrieve Information Model - GET	1.2.840.10008.5.1.4.1.2.1.3
Study Root Query/Retrieve Information Model - FIND	1.2.840.10008.5.1.4.1.2.2.1
Study Root Query/Retrieve Information Model - MOVE	1.2.840.10008.5.1.4.1.2.2.2
Study Root Query/Retrieve Information Model - GET	1.2.840.10008.5.1.4.1.2.2.3
Patient/Study Only Query/Retrieve Information Model - FIND	1.2.840.10008.5.1.4.1.2.3.1
Patient/Study Only Query/Retrieve Information Model – MOVE	1.2.840.10008.5.1.4.1.2.3.2
Patient/Study Only Query/Retrieve Information Model - GET	1.2.840.10008.5.1.4.1.2.3.3

Table 18 Supported SOP Classes as SCP

**Note:** See also the Storage DICOM Conformance Statement of the AXIOM Artis VB22 DICOM application to compare for conformance of the C-STORE sub-operation generated by the C-GET or C-MOVE DIMSE services. Furthermore compare the supported Storage Service SOP classes described in the Storage DICOM Conformance Statement of the Modality to which the images shall be transferred to.

**9.1.1 Association Establishment Policies**

**9.1.1.1 General**

With the “Search...” function the query data are input and the DICOM query/retrieve application is started. A query request will be sent out to one remote node that can be selected from a list of configured Query Providers and the response data will be displayed for the user. Upon request (Import), the retrieval of selected items is initiated.

The default PDU size used will be 256 KB.

**9.1.1.2 Number of Associations**

The AXIOM Artis VB22 DICOM application initiates one association for each query request being processed to a remote node. The maximum number of active associations is configurable.

The AXIOM Artis VB22 DICOM application is able to accept multiple associations at a time. It can handle up to 10 associations in parallel.

**9.1.1.3 Asynchronous Nature**

The AXIOM Artis VB22 DICOM software does not support asynchronous communication (multiple outstanding transactions over a single association).

**9.1.1.4 Implementation Identifying Information**

Implementation Class UID	1.3.12.2.1107.5.5.9.20000101
Implementation Version Name	SIEMENS_SWFVX47A

Table 19 Implementation Identifying Information

**9.1.2 Association Initiation Policy**

The query user interface will request the query-data from the user and triggers one C-FIND request to the selected remote node. The response data will be displayed in the query UI for further data navigation.

When requesting Import of related items the browser requests the retrieve application to send a C-MOVE request to the related remote node. Images will then be received by the Storage SCP as described in the related section.

The query/retrieve operation can be canceled at any time by a respective C-FIND-CANCEL or C-MOVE-CANCEL.

**9.1.2.1 Real World Activity - Find SCU**

**9.1.2.1.1 Associated Real-World Activity - Find SCU “Search”**

The associated Real-World activity is to fill out a query form with search data and pass it as query to the network application which issues a C-FIND over a previously built association. The remote SCP will respond with related data-entries that will be passed to a browser application. When data transfer is finished the association is closed.

**9.1.2.1.2 Proposed Presentation Contexts - Find SCU**

The AXIOM Artis VB22 DICOM application will propose Presentation Contexts as shown in the following table:

Presentation Context Table					
Abstract Syntax		Transfer Syntax		Role	Ext. Neg.
Name	UID	Name List	UID List		
Patient Root Query/Retrieve Model - FIND	1.2.840.10008.5.1.4.1.2.1.1	Implicit VR Little Endian Explicit VR Little Endian Explicit VR Big Endian	1.2.840.10008.1.2 1.2.840.10008.1.2.1 1.2.840.10008.1.2.2	SCU	None
Study Root Query/Retrieve Model - FIND	1.2.840.10008.5.1.4.1.2.2.1	Implicit VR Little Endian Explicit VR Little Endian Explicit VR Big Endian	1.2.840.10008.1.2 1.2.840.10008.1.2.1 1.2.840.10008.1.2.2	SCU	None

Table 20 Proposed Presentation Contexts - Find SCU

It is configurable which of the two query models (or both) are to be used by the AXIOM Artis VB22 DICOM Query SCU application. If both Abstract Syntaxes are configured, The C-FIND SCU will use the Patient Root Model only for C-FIND requests on PATIENT level. For all other levels it will use the STUDY root model.

**9.1.2.1.3 Conformance Statement - Find SCU**

The AXIOM Artis VB22 DICOM Query/Retrieve SCU supports hierarchical queries with all mandatory search keys. The interactive querying of attributes on IMAGE level is supported by the Query SCU, hence but no search criteria can be entered. So image level is always queried with a fixed list of "universal(Null)" values.

The following table describes the search keys for the different query models that the SCU supports. Matching is either wildcard, which means that the user can supply a string containing wildcards, or universal, which means that the attribute is requested as return value.

Attribute name	Tag	Type	Matching	User input	return value display
<b>Patient Level <sup>a</sup></b>					
Patient Name	(0010,0010)	R	Wildcard <sup>b</sup>	enter value	yes
Patient ID	(0010,0020)	U	Wildcard	enter value	yes
Patient's Birth date	(0010,0030)	O	universal (Null)	enter value	yes
Patient's Sex	(0010,0040)	O	universal (Null)	enter value	yes
Number of Patient related Studies	(0020,1200)	O	universal (Null)	-	yes <sup>b</sup>
Number of Patient related Series	(0020,1202)	O	universal (Null)	-	no
Number of Patient related Instances	(0020,1204)	O	universal (Null)	-	no
<b>Study Level</b>					

a Patient Root Information Model only

b Always a "\*" is appended to the user-supplied string

c Implicitly visualized in the UI if no study and series search attributes have been entered

d Study Root model only

Attribute name	Tag	Type	Matching	User input	return value display
Patient Name <sup>d</sup>	(0010,0010)	R	Wildcard <sup>b</sup>	enter value	yes
Patient ID	(0010,0020)	R	Wildcard <sup>b</sup>	enter value	yes
Patient's Birth date <sup>d</sup>	(0010,0030)	O	universal (Null)	enter value	yes
Patient's Sex <sup>d</sup>	(0010,0040)	O	universal (Null)	enter value	yes
Study Instance UID	(0020,000D)	U	single value	-	yes
Study ID	(0020,0010)	R	universal (Null)	enter value	yes
Study Date	(0008,0020)	R	universal (Null)	enter value	yes
Study Time	(0008,0030)	R	universal (Null)	-	yes
Accession Number	(0008,0050)	R	universal (Null)	-	yes
Study Description	(0008,1030)	O	universal (Null)	-	yes
Referring Physician's Name	(0008,0090)	O	universal (Null)	-	yes
Name of Physician Reading Study	(0008,1060)	O	universal (Null)	-	yes
Modalities in Study	(0008,0061)	O	universal (Null)	-	yes
Storage Media File-Set ID	(0008,0130)	O	universal (Null)	-	no
Retrieve AE Title	(0008,0054)	O	universal (Null)	-	no
Number of Study related Series	(0020,1206)	O	universal (Null)	-	yes
Number of Study related Instances	(0020,1208)	O	universal (Null)	-	no
<b>Series Level</b>					
Series Instance UID	(0020,000E)	U	single value	-	yes
Series Number	(0020,0011)	R	universal (Null)	-	yes
Modality	(0008,0060)	R	universal (Null)	enter value	yes
Series Date	(0008,0021)	O	universal (Null)	-	yes
Series Time	(0008,0031)	O	universal (Null)	-	yes
Series Description	(0008,103E)	O	universal (Null)	enter value	yes
Body Part Examined	(0018,0015)	O	universal (Null)	enter value	yes
Performing Physician	(0008,1050)	O	universal (Null)	enter value	yes
Storage Media File-Set ID	(0008,0130)	O	universal (Null)	-	yes
Retrieve AE Title	(0008,0054)	O	universal (Null)	-	yes
Protocol Name	(0018,1030)	O	universal (Null)	-	no
Perf. Procedure Step Start Date	(0040,0244)	O	universal (Null)	-	yes
Perf. Procedure Step Start Time	(0040,0245)	O	universal (Null)	-	yes
Requested Attribute Sequence	(0040,0275)	O	universal (Null)	-	yes
> Requested	(0040,1001)	O	universal (Null)	-	yes

Attribute name	Tag	Type	Matching	User input	return value display
Procedure ID					
> Scheduled Procedure ID	(0040,0009)	O	universal (Null)	-	yes
Number of Series related Instances	(0020,1209)	O	universal (Null)	-	yes
<b>Image Level</b>					
SOP Instance UID	(0008,0018)	U	single value	-	no
Image Number	(0020,0013)	R	universal (Null)	-	yes
Storage Media File-Set ID	(0008,0130)	O	universal (Null)	-	no
Retrieve AE Title	(0008,0054)	O	universal (Null)	-	no
Instance Date	(0008,0023)	O	universal (Null)	-	no
Instance Time	(0008,0033)	O	universal (Null)	-	no
Number of Frames	(0028,0008)	O	universal (Null)	-	yes
Image Comments	(0020,4000)	O	universal (Null)	-	no

Table 21 Search keys for Query models - Find SCU

The Find SCU interprets following status codes:

Service Status	Meaning	Protocol Codes	Related Fields
Refused	Out of Resources	A700	(0000,0902)
Failed	Identifier does not match SOP Class	A900	(0000,0901) (0000,0902)
	Unable to process	Cxxx	(0000,0901) (0000,0902)
Cancel	Matching terminated due to Cancel request	FE00	None
Success	Matching is complete - No final Identifier is supplied	0000	None
Pending	Matches are continuing - Current Match is supplied and any Optional Keys were supported in the same manner as Required Keys	FF00	Identifier
	Matches are continuing - Warning that one or more Optional Keys were not supported for existence and/or matching for this identifier	FF01	Identifier

Table 22 C-FIND response status

### 9.1.2.2 Real-World Activity – Move SCU

#### 9.1.2.2.1 Associated Real-World Activity – Move SCU “Import”

When selecting a data entry in the Query UI and activate the “Import” function, a retrieval request is passed to the archival application which issues a C-MOVE service according to the Patient Root or Study Root query model. (The Storage Service Class Conformance Statement describes the C-STORE service, which is generated by processing the C-MOVE service.)

The transferred image data are processed as described in the storage class SCP descriptions.

The possibility to request the remote C-MOVE provider (remote application that responded to the C-FIND) to move data to an application entity other than the C-MOVE SCU (the AXIOM Artis VB22 DICOM application) is NOT USED.

C-MOVE operation on Patient Level is not supported by the Query UI.

**9.1.2.2.2 Proposed Presentation Contexts - Move SCU “Import”**

The AXIOM Artis VB22 DICOM application will propose Presentation Contexts as shown in the following table:

Presentation Context Table					
Abstract Syntax		Transfer Syntax		Role	Ext. Neg.
Name	UID	Name List	UID List		
Patient Root Query/Retrieve Model – MOVE	1.2.840.10008.5.1.4.1.2.1.2	Implicit VR Little Endian Explicit VR Little Endian Explicit VR Big Endian	1.2.840.10008.1.2 1.2.840.10008.1.2.1 1.2.840.10008.1.2.2	SCU	None
Study Root Query/Retrieve Model – MOVE	1.2.840.10008.5.1.4.1.2.2.2	Implicit VR Little Endian Explicit VR Little Endian Explicit VR Big Endian	1.2.840.10008.1.2 1.2.840.10008.1.2.1 1.2.840.10008.1.2.2	SCU	None

Table 23 Proposed Presentation Contexts - Move SCU “Import”

**Note:** C-MOVE extended negotiation will not be supported by the SCU

**9.1.2.2.3 SOP Specific Conformance Statement - Move SCU “Import”**

At association establishment time the C-MOVE presentation context shall be negotiated. The C-STORE sub-operations must be done on a different association to transfer images to the own Storage Service Class SCP.

The Move SCU interprets following status codes:

Service Status	Meaning	Error Codes	Related Fields
Refused	Out of Resources - Unable to calculate number of matches	A701	(0000,0902)
	Out of Resources - Unable to perform sub operations	A702	(0000,1020) (0000,1021) (0000,1022) (0000,1023)
Failed	Identifier does not match SOP Class	A900	(0000,0901) (0000,0902)
	Unable to process	CXXX	(0000,0901) (0000,0902)
Cancel	Sub-operations terminated due to Cancel Indication	FE00	(0000,1020) (0000,1021) (0000,1022) (0000,1023)
Warning	Sub-operations Complete - One or more Failures or Warnings	B000	(0000,1020) (0000,1021) (0000,1022) (0000,1023)
Success	Sub-operations Complete - No Failures or Warning	0000	(0000,1020) (0000,1021) (0000,1022) (0000,1023)
Pending	Sub-operations are continuing	FF00	(0000,1020) (0000,1021) (0000,1022) (0000,1023)

Table 24 Status Codes - Move SCU “Import”

**9.1.3 Association Acceptance Policy**

The AXIOM Artis VB22 DICOM application will accept associations for the following DIMSE-C operations as SCP:

- C-FIND
- C-GET
- C-MOVE
- C-FIND-CANCEL
- C-GET-CANCEL
- C-MOVE-CANCEL

Extended negotiation - which is relational retrieve - is NOT supported for the above listed services. The AXIOM Artis DICOM application does support multiple C-FIND requests over the same association, while multiple C-MOVE or C-GET operations are not supported over the same association.

**9.1.3.1 Real-World Activity - Find SCP**

**9.1.3.1.1 Associated Real-World Activity - Find SCP**

The associated Real-World activity is to respond query requests to an SCU with the query model Patient Root, Study Root and Patient/Study Only. Relational retrieve operation is NOT supported. With a C-FIND-CANCEL request the running query can be canceled at any time.

Multiple C-FIND requests over the same association are supported.

**9.1.3.1.2 Accepted Presentation Contexts - Find SCP**

The AXIOM Artis VB22 DICOM application will accept Presentation Contexts as shown in the following table:

Presentation Context Table					
Abstract Syntax		Transfer Syntax		Role	Ext. Neg.
Name	UID	Name List	UID List		
Patient Root Query/Retrieve Model – FIND	1.2.840.10008.5.1.4.1.2.1.1	Implicit VR Little Endian Explicit VR Little Endian Explicit VR Big Endian	1.2.840.10008.1.2 1.2.840.10008.1.2.1 1.2.840.10008.1.2.2	SCP	None
Study Root Query/Retrieve Model – FIND	1.2.840.10008.5.1.4.1.2.2.1	Implicit VR Little Endian Explicit VR Little Endian Explicit VR Big Endian	1.2.840.10008.1.2 1.2.840.10008.1.2.1 1.2.840.10008.1.2.2	SCP	None
Patient/Study Only Query/Retrieve Model – FIND	1.2.840.10008.5.1.4.1.2.3.1	Implicit VR Little Endian Explicit VR Little Endian Explicit VR Big Endian	1.2.840.10008.1.2 1.2.840.10008.1.2.1 1.2.840.10008.1.2.2	SCP	None

Table 25 Accepted Presentation Contexts - Find SCP

**Note:** C-FIND Extended Negotiation will NOT be supported.  
The order of preference for accepting Transfer Syntaxes is: 1. Explicit VR Little Endian, 2. Explicit VR Big Endian, 3. Implicit VR Little Endian

**9.1.3.1.3 SOP Specific Conformance Statement - Find SCP**

The AXIOM Artis VB22 DICOM Query/Retrieve SCP supports hierarchical queries with all mandatory and optional search keys.

The query attribute contents will be treated case-sensitive.

With wildcard queries the symbol “?” is treated as “\*” by the C-FIND SCP application. As a consequence the query string of “?abc\*” will be processed as “\*abc\*”.

If the value for the patient-level unique key “Patient ID” is not known, it may be returned with zero length. The attribute “Image Comments” will not be included in the C-FIND-RSP, if it is not set in the DB, even if it was requested as return key in the related C-FIND-RQ.

Usage of Storage Media File-Set ID, Retrieve AE Title with C-FIND-RSP message:

- The Storage Media File-Set ID - if existent - can be returned at Study/Series/Image Level. Only on Image Level, the values of ONLINE, NEARLINE or OFFLINE are returned to indicate the Storage Location of the related Instance.
- The Retrieve AE Title - if existent - can only be returned at Image Level (for Patient Root and Study Root models) or Study Level (for Patient/Study Only model).

Relational Queries are **not** supported.

A remote DICOM AE can cancel the running query by sending a C-FIND-CANCEL. Matches are possibly continuing (more C-FIND response with status PENDING) until the cancel operation has completed.

The supported attributes on the various query levels of the three supported information models are list in the tables of the following sections.

**9.1.3.1.3.1 Patient Root Information Model**

Attribute Name	Tag	Usage SCU	Matching
<b>Patient Level</b>			
Patient Name	(0010,0010)	R	single value, wildcard, universal
Patient ID	(0010,0020)	U	single value, wildcard, universal
Patient's Birth Date	(0010,0030)	O	single value, range, universal
Patient's Birth Time	(0010,0032)	O	single value, range, universal
Patient's Sex	(0010,0040)	O	single value, wildcard, universal
Ethnic Group	(0010,2160)	O	single value, wildcard, universal
Patient Comments	(0010,4000)	O	wildcard, universal
Number of Patient related Studies	(0020,1200)	O	universal
Number of Patient related Series	(0020,1202)	O	universal
Number of Patient related Instances	(0020,1204)	O	universal
<b>Study Level</b>			
Study Instance UID	(0020,000D)	U	single value, list of UIDs
Study ID	(0020,0010)	R	single value, wildcard, universal
Study Date	(0008,0020)	R	single value, range, universal
Study Time	(0008,0030)	R	single value, range, universal
Accession Number	(0008,0050)	R	single value, wildcard, universal
Referring Physician's Name	(0008,0090)	O	single value, wildcard, universal

Attribute Name	Tag	Usage SCU	Matching
Study Description	(0008,1030)	O	single value, wildcard, universal
Admitting Diagnoses Description	(0008,1080)	O	single value, wildcard, universal
Patient's Age	(0010,1010)	O	single value, wildcard, universal
Patient's Size	(0010,1020)	O	single value, universal
Patient's Weight	(0010,1030)	O	single value, universal
Occupation	(0010,2180)	O	single value, wildcard, universal
Additional Patient History	(0010,21B0)	O	wildcard, universal
Name of Physician reading Study	(0008,1060)	O	single value, wildcard, universal
Modalities in Study	(0008,0061)	O	multiple values, universal
Number of Study related Series	(0020,1206)	O	universal
Number of Study related Instances	(0020,1208)	O	universal
<b>Series Level</b>			
Series Instance UID	(0020,000E)	U	single value, list of UID
Series Number	(0020,0011)	R	single value, universal
Modality	(0008,0060)	R	single value, wildcard, universal
Laterality	(0020,0060)	O	single value, wildcard, universal
Body Part Examined	(0018,0015)	O	single value, wildcard, universal
Patient Position	(0018,5100)	O	single value, wildcard, universal
Smallest Pixel Value in Series	(0028,0108)	O	single value, universal
Largest Pixel Value in Series	(0028,0109)	O	single value, universal
Protocol Name	(0018,1030)	O	single value, wildcard, universal
Series Date	(0008,0021)	O	single value, range, universal
Series Time	(0008,0031)	O	single value, range, universal
Series Description	(0008,103E)	O	single value, wildcard, universal
Operators Name	(0008,1070)	O	single value, wildcard, universal
Performing Physician's Name	(0008,1050)	O	single value, wildcard, universal
Perf. Procedure Step Start Date	(0040,0244)	O	universal
Perf. Procedure Step Start Time	(0040,0245)	O	universal
Number of Series related Instances	(0020,1209)	O	universal
<b>Image Level</b>			
SOP Instance UID	(0008,0018)	U	single value, list of UID
Image Number	(0020,0013)	R	single value, universal
Image Date	(0008,0023)	O	single value, range, universal
Image Time	(0008,0033)	O	single value, range, universal
Modality	(0008,0060)	O	single value, wildcard, universal
Image Comments	(0020,4000)	O	Universal

Table 26 Supported Query attributes sorted by Query Level – Patient Root Information Model

## 9.1.3.1.3.2 Study Root Information Model

Attribute Name	Tag	Usage SCU	Matching
<b>Study Level</b>			
Patient Name	(0010,0010)	R	Single value, Wildcard, universal
Patient ID	(0010,0020)	R	Single Value, Wildcard, universal
Patient's Birth Date	(0010,0030)	O	Single Value, Range, universal
Patient's Birth Time	(0010,0032)	O	Single Value, Range, universal
Patient's Sex	(0010,0040)	O	Single Value, Wildcard, universal
Patient Comments	(0010,4000)	O	Wildcard, universal
Number of Patient related Studies	(0020,1200)	O	universal
Number of Patient related Series	(0020,1202)	O	universal
Number of Patient related Instances	(0020,1204)	O	universal
Study Instance UID	(0020,000D)	U	Single Value, List of UIDs
Study ID	(0020,0010)	R	Single Value, Wildcard, universal
Study Date	(0008,0020)	R	Single Value, Range, universal
Study Time	(0008,0030)	R	Single Value, Range, universal
Accession Number	(0008,0050)	R	Single Value, Wildcard, universal
Referring Physician's Name	(0008,0090)	O	Single Value, Wildcard, universal
Study Description	(0008,1030)	O	Single Value, Wildcard, universal
Admitting Diagnosis Description	(0008,1080)	O	Single Value, Wildcard, universal
Patient's Age	(0010,1010)	O	Single Value, Wildcard, universal
Patient's Size	(0010,1020)	O	Single Value, universal
Patient's Weight	(0010,1030)	O	Single Value, universal
Occupation	(0010,2180)	O	Single Value, Wildcard, universal
Additional Patient History	(0010,21B0)	O	Wildcard, universal
Name of Physician reading the Study	(0008,1060)	O	Single Value, Wildcard, universal
Modalities in Study	(0008,0061)	O	Multiple values, universal
Number of Study Related Series	(0020,1206)	O	universal
Number of Study Related Instances	(0020,1208)	O	universal
<b>Series Level</b>			
Series Instance UID	(0020,000E)	U	Single Value, List of UIDs
Series Number	(0020,0011)	R	Single Value, universal
Modality	(0008,0060)	R	Single Value, Wildcard, universal
Laterality	(0020,0060)	O	Single Value, Wildcard, universal
Body Part Examined	(0018,0015)	O	Single Value, Wildcard, universal
Patient Position	(0018,5100)	O	Single Value, Wildcard, universal
Smallest Pixel Value in Series	(0028,0108)	O	Single Value, universal
Largest Pixel Value in Series	(0028,0109)	O	Single Value, universal
Protocol Name	(0018,1030)	O	Single Value, Wildcard, universal
Series Date	(0008,0021)	O	Single Value, Range, universal
Series Time	(0008,0031)	O	Single Value, Range, universal
Series Description	(0008,103E)	O	Single Value, Wildcard, universal
Operator's Name	(0008,1070)	O	Single Value, Wildcard, universal
Performing Physician's Name	(0008,1050)	O	Single Value, Wildcard, universal
Performed Procedure Step Start Date	(0040,0244)	O	universal
Performed Procedure Step Start Time	(0040,0245)	O	universal
Number of Series related Instances	(0020,1209)	O	universal
<b>Image Level</b>			
SOP Instance UID	(0008,0018)	U	Single Value, List of UIDs
Image Number	(0020,0013)	R	Single Value, universal
Image Date	(0008,0023)	O	Single Value, Range, universal
Image Time	(0008,0033)	O	Single Value, Range, universal
Modality	(0008,0060)	O	Single Value, Wildcard, universal

Attribute Name	Tag	Usage SCU	Matching
Image Comments	(0020,4000)	O	universal

Table 27 Supported Query attributes sorted by Query Level – Study Root Information Model

9.1.3.1.3.3 Patient/Study Only Information Model

Attribute Name	Tag	Usage SCU	Matching
<b>Patient Level</b>			
Patient Name	(0010,0010)	R	Single value, Wildcard, universal
Patient ID	(0010,0020)	U	Single Value, Wildcard, universal
Patient's Birth Date	(0010,0030)	O	Single Value, Range, universal
Patient's Birth Time	(0010,0032)	O	Single Value, Range, universal
Patient's Sex	(0010,0040)	O	Single Value, Wildcard, universal
Ethnic Group	(0010,2160)	O	Single Value, Wildcard, universal
Patient Comments	(0010,4000)	O	Wildcard, universal
Number of Patient related Studies	(0020,1200)	O	universal
Number of Patient related Series	(0020,1202)	O	universal
Number of Patient related Instances	(0020,1204)	O	universal
<b>Study Level</b>			
Study Instance UID	(0020,000D)	U	Single Value, List of UIDs
Study ID	(0020,0010)	R	Single Value, Wildcard, universal
Study Date	(0008,0020)	R	Single Value, Range, universal
Study Time	(0008,0030)	R	Single Value, Range, universal
Accession Number	(0008,0050)	R	Single Value, Wildcard, universal
Referring Physician's Name	(0008,0090)	O	Single Value, Wildcard, universal
Study Description	(0008,1030)	O	Single Value, Wildcard, universal
Admitting Diagnosis Description	(0008,1080)	O	Single Value, Wildcard, universal
Patient's Age	(0010,1010)	O	Single Value, Wildcard, universal
Patient's Size	(0010,1020)	O	Single Value, universal
Patient's Weight	(0010,1030)	O	Single Value, universal
Occupation	(0010,2180)	O	Single Value, Wildcard, universal
Additional Patient History	(0010,21B0)	O	Wildcard, universal
Name of Physician reading the Study	(0008,1060)	O	Single Value, Wildcard, universal
Modalities in Study	(0008,0061)	O	Multiple values, universal
Number of Study Related Series	(0020,1206)	O	universal
Number of Study Related Instances	(0020,1208)	O	universal

Table 28 Supported Query attributes sorted by Query Level – Patient/Study only Information Model

The Find SCP returns following status codes:

Service Status	Meaning	Error Codes	Related Fields
Refused	Out of Resources	A700	(0000,0902)
Failed	Identifier does not match SOP Class	A900	(0000,0901) (0000,0902)
	Unable to process	C001	(0000,0901) (0000,0902)
Cancel	Matching terminated due to Cancel request	FE00	None
Success	Matching is complete - No final Identifier is supplied	0000	None
Pending	Matches are continuing - Current Match is supplied and any Optional Keys were supported in the same manner as Required Keys	FF00	Identifier
	Matches are continuing - Warning that one or more Optional Keys were not supported for existence and/or matching for this identifier	FF01	Identifier

Table 29 Status Codes

**9.1.3.2 Real-World Activity - Get SCP**

**9.1.3.2.1 Associated Real-World Activity - Get SCP**

The associated Real-World activity is to respond to retrieve requests initiated from a foreign SCU. The SCP supports the query model Patient Root, Study Root and Patient/Study Only. The Storage Service Class Conformance Statement describes the C-STORE service, which is generated by the C-GET service. Relational retrieve operation is NOT supported.

Multiple C-GET requests over the same association are NOT supported.

**9.1.3.2.2 Accepted Presentation Contexts - Get SCP**

The AXIOM Artis VB22 DICOM application will accept Presentation Contexts as shown in the following table:

Presentation Context Table					
Abstract Syntax		Transfer Syntax		Role	Ext. Neg.
Name	UID	Name List	UID List		
Patient Root Query/Retrieve Model – GET	1.2.840.10008.5.1.4.1.2.1.3	Implicit VR Little Endian Explicit VR Little Endian Explicit VR Big Endian	1.2.840.10008.1.2 1.2.840.10008.1.2.1 1.2.840.10008.1.2.2	SCP	None
Study Root Query/Retrieve Model – GET	1.2.840.10008.5.1.4.1.2.2.3	Implicit VR Little Endian Explicit VR Little Endian Explicit VR Big Endian	1.2.840.10008.1.2 1.2.840.10008.1.2.1 1.2.840.10008.1.2.2	SCP	None
Patient/Study Only Query/Retrieve Model – GET	1.2.840.10008.5.1.4.1.2.3.3	Implicit VR Little Endian Explicit VR Little Endian Explicit VR Big Endian	1.2.840.10008.1.2 1.2.840.10008.1.2.1 1.2.840.10008.1.2.2	SCP	None

Table 30 Accepted Presentation Contexts - Get SCP

**Note:** C-GET Extended negotiation will NOT be supported.  
The order of preference for accepting Transfer Syntaxes is: 1. Explicit VR Little Endian, 2. Explicit VR Big Endian, 3. Implicit VR Little Endian.

**9.1.3.2.3 SOP Specific Conformance Statement - Get SCP**

At association establishment time the C-GET presentation context must be negotiated along with the C-STORE sub-operations which must be accomplished on the same association as the C-GET operation. Relational retrieve operation is NOT supported.

The Get SCP returns following status codes:

Service Status	Meaning	Error Codes	Related Fields
Refused	Out of Resources - Unable to calculate number of matches	A701	(0000,0902)
	Out of Resources - Unable to perform sub operations	A702	(0000,1020) (0000,1021) (0000,1022) (0000,1023)
Failed	Identifier does not match SOP Class	A900	(0000,0901) (0000,0902)
	Unable to process	C001	(0000,0901) (0000,0902)
Cancel	Sub-operations terminated due to Cancel Indication	FE00	(0000,1020) (0000,1021) (0000,1022) (0000,1023)
Warning	Sub-operations Complete - One or more Failures of	B000	(0000,1020)

Service Status	Meaning	Error Codes	Related Fields
	Warnings		(0000,1021) (0000,1022) (0000,1023)
Success	Sub-operations Complete - No Failures or Warning	0000	(0000,1020) (0000,1021) (0000,1022) (0000,1023)
Pending	Sub-operations are continuing	FF00	(0000,1020) (0000,1021) (0000,1022) (0000,1023)

Table 31 Status Codes

### 9.1.3.3 Real-World Activity - Move SCP

#### 9.1.3.3.1 Associated Real-World Activity - Move SCP

The associated Real-World activity is to respond to retrieve requests to an SCU. The SCP supports the query model Patient Root, Study Root and Patient/Study Only. The Storage Service Class Conformance Statement describes the C-STORE service, which is generated by the C-MOVE service. Relational retrieve operation is NOT supported.

Multiple C-MOVE requests over the same association are NOT supported.

#### 9.1.3.3.2 Accepted Presentation Contexts - Move SCP

The AXIOM Artis VB22 DICOM application will accept Presentation Contexts as shown in the following table:

Presentation Context Table					
Abstract Syntax		Transfer Syntax		Role	Ext. Neg.
Name	UID	Name List	UID List		
Patient Root Query/Retrieve Model – MOVE	1.2.840.10008.5.1.4.1.2.1.2	Implicit VR Little Endian Explicit VR Little Endian Explicit VR Big Endian	1.2.840.10008.1.2 1.2.840.10008.1.2.1 1.2.840.10008.1.2.2	SCP	None
Study Root Query/Retrieve Model – MOVE	1.2.840.10008.5.1.4.1.2.2.2	Implicit VR Little Endian Explicit VR Little Endian Explicit VR Big Endian	1.2.840.10008.1.2 1.2.840.10008.1.2.1 1.2.840.10008.1.2.2	SCP	None
Patient/Study Only Query/Retrieve Model – MOVE	1.2.840.10008.5.1.4.1.2.3.2	Implicit VR Little Endian Explicit VR Little Endian Explicit VR Big Endian	1.2.840.10008.1.2 1.2.840.10008.1.2.1 1.2.840.10008.1.2.2	SCP	None

Table 32 Accepted Presentation Contexts - Move SCP

**Note:** C-MOVE Extended negotiation will NOT be supported.  
The order of preference for accepting Transfer Syntaxes is: 1. Explicit VR Little Endian, 2. Explicit VR Big Endian, 3. Implicit VR Little Endian.

#### 9.1.3.3.3 SOP Specific Conformance Statement - Move SCP

At association establishment time the C-MOVE presentation context shall be negotiated. The C-STORE sub-operations is done on a different association, specified in the C-MOVE request, to transfer images to a remote SCP of the Storage Service Class. Relational retrieve operation is NOT supported.

The Move SCP returns following status codes:

Service Status	Meaning	Error Codes	Related Fields
Refused	Out of Resources - Unable to calculate number of matches	A701	(0000,0902)
	Out of Resources - Unable to perform sub operations	A702	(0000,1020) (0000,1021) (0000,1022) (0000,1023)
Failed	Identifier does not match SOP Class	A900	(0000,0901) (0000,0902)
	Unable to process	C001	(0000,0901) (0000,0902)
Cancel	Sub-operations terminated due to Cancel Indication	FE00	(0000,1020) (0000,1021) (0000,1022) (0000,1023)
Warning	Sub-operations Complete - One or more Failures of Warnings	B000	(0000,1020) (0000,1021) (0000,1022) (0000,1023)
Success	Sub-operations Complete - No Failures or Warning	0000	(0000,1020) (0000,1021) (0000,1022) (0000,1023)
Pending	Sub-operations are continuing	FF00	(0000,1020) (0000,1021) (0000,1022) (0000,1023)

Table 33 Status Codes

## 10 Implementation Model Print

The Print Management Service Classes define an application-level class of services, which facilitate the printing of images on a hardcopy medium. The print management SCU and print management SCP are peer DICOM print management application entities. The *syngo* DICOM print application supports the print management DIMSE services to act as SCU.

### 10.1 Application Data Flow Diagram

The *syngo* DICOM network implementation acts as SCU for the print management network service. The product target Operating System is Windows XP.

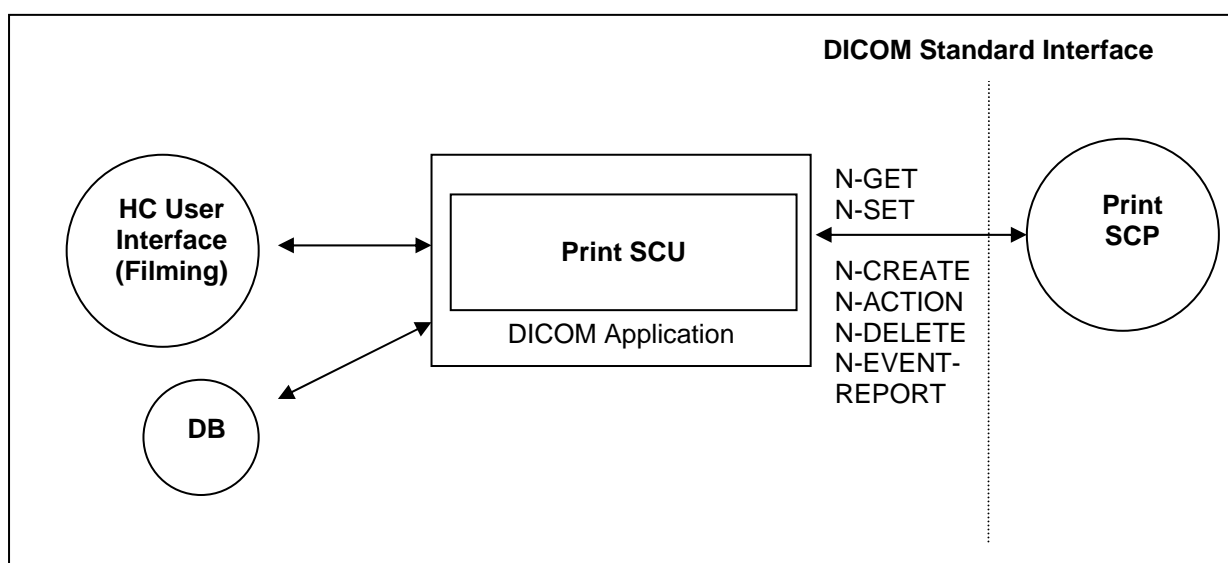

Figure 6 DICOM Application Data Flow Diagram – Print SCU

### 10.2 Functional Definition of Application Entities

The Print SCU is invoked by the user interface to setup film-sheet layout and whenever an image is ready to be printed on film. The Print SCU will hold and maintain all data needed to compile a complete film-sheet from the data (images, layout, configuration) received. Whenever a film-sheet is ready to print the related data is used to supply the Information to the SOP Classes of the Print Management Service Class. A queue is maintained, in order to intermediately store several film-sheets in case of resource problems on printer. The SCU will only supply and require the mandatory SOP Classes of the Print Management Service Class.

### 10.3 Sequencing of Real-World Activities

Not applicable

## 11 Application Entity Specification Print

### 11.1 Print Management AE Specification

The *syngo* print management SCU invokes print management DIMSE services to transfer images from the local AE to the remote SCP AE to print images with defined layout on a selected network-based DICOM hardcopy printer. This is done in a "full-page" print mode.

SIEMENS *syngo* DICOM products provide Standard Conformance to the following DICOM Print Management Meta SOP Classes as an SCU:

SOP Class Name	SOP Class UID
Basic Grayscale Print Management Meta SOP Class	1.2.840.10008.5.1.1.9
- Basic Film Session SOP Class	1.2.840.10008.5.1.1.1
- Basic Film Box SOP Class	1.2.840.10008.5.1.1.2
- Basic Grayscale Image Box SOP Class	1.2.840.10008.5.1.1.4
- Printer SOP Class	1.2.840.10008.5.1.1.16
Print Job SOP Class	1.2.840.10008.5.1.1.14

Table 34 Basic Grayscale Print Management Meta SOP Class

#### 11.1.1 Association Establishment Policies

##### 11.1.1.1 General

Whenever a film is completely set up and printed by command or automatism, the job is prepared for processing. As soon as the queue is ready to process, the job is activated and works according to the processing data. The related Print application will initiate an association to the print destination and process the printing of the related information.

The default PDU size used will be 256 KB.

##### 11.1.1.2 Number of Associations

The *syngo* DICOM Print application initiates one association at a time for each different print device configured.

##### 11.1.1.3 Asynchronous Nature

The *syngo* DICOM software does not support asynchronous communication (multiple outstanding transactions over a single association).

**11.1.1.4 Implementation Identifying Information**

Implementation Class UID	1.3.12.2.1107.5.5.9.20000101
Implementation Version Name	SIEMENS_SWFVX47A

Table 35 Implementation Identifying Information

**11.1.2 Association Initiation Policy**

Triggered by the Print job queue the Print Management SCU establishes an association by using the DICOM association services. With the help of the N-GET request for the Printer SOP Class the Status is determined before printing.

With no problem encountered with the N-CREATE/N-SET Services for the related Basic Print SOP Classes the film sheet is set up for printing and the image(s) is(are) transferred to the printer device.

After the last film is printed from queue, the Print application will leave open the association for another 60 seconds. If a new film job is ready for printing within this time-limit, the job will be immediately processed over the still open association. If there is no new job, the association is closed if the time-out elapsed. This is done to optimize automated printing.

During the “idle-time” (no open association to printer) the Print application will issue a cyclic camera status request (using N-GET of Printer SOP Class) every 5 minutes.

**11.1.2.1 Associated Real-World Activity**

**11.1.2.1.1 Associated Real-World Activity – Printing a Printer Job Queue Entry**

Whenever the user prepares a film-sheet it is forwarded to the Printer Job queue. If the associated Printer device is available, the job is activated by opening an association to this device.

The film sheet is internally processed, converted to a Standard/1-1 page and then the page image is sent.

If the response from the remote application contains a status other than Success or Warning the association is aborted.

**11.1.2.1.2 Proposed Presentation Context (Presentation Context Table)**

The Siemens *syngo* DICOM Print application will propose Presentation Contexts as shown in the following table:

Presentation Context Table					
Abstract Syntax		Transfer Syntax		Role	Ext. Neg.
Name	UID	Name List	UID List		
Basic Grayscale Print Management Meta SOP class	1.2.840.10008.5.1.1.9	Implicit VR Little Endian Explicit VR Little Endian Explicit VR Big Endian	1.2.840.10008.1.2 1.2.840.10008.1.2.1 1.2.840.10008.1.2.2	SCU	None
Basic film session SOP class	1.2.840.10008.5.1.1.1	Implicit VR Little Endian Explicit VR Little Endian Explicit VR Big Endian	1.2.840.10008.1.2 1.2.840.10008.1.2.1 1.2.840.10008.1.2.2	SCU	None
Basic Film Box SOP class	1.2.840.10008.5.1.1.2	Implicit VR Little Endian Explicit VR Little Endian Explicit VR Big Endian	1.2.840.10008.1.2 1.2.840.10008.1.2.1 1.2.840.10008.1.2.2	SCU	None
Basic Grayscale Image Box SOP class	1.2.840.10008.5.1.1.4	Implicit VR Little Endian Explicit VR Little Endian Explicit VR Big Endian	1.2.840.10008.1.2 1.2.840.10008.1.2.1 1.2.840.10008.1.2.2	SCU	None
Printer SOP class	1.2.840.10008.5.1.1.16	Implicit VR Little Endian Explicit VR Little Endian Explicit VR Big Endian	1.2.840.10008.1.2 1.2.840.10008.1.2.1 1.2.840.10008.1.2.2	SCU	None
Print Job SOP class	1.2.840.10008.5.1.1.14	Implicit VR Little Endian Explicit VR Little Endian Explicit VR Big Endian	1.2.840.10008.1.2 1.2.840.10008.1.2.1 1.2.840.10008.1.2.2	SCU	None

Table 36 Proposed Presentation Contexts

**11.1.2.1.3 SOP specific Conformance Statement – Meta SOP Classes**

The *syngo* DICOM print management SCU conforms to the DICOM Basic Grayscale Print Management Meta SOP.

The application uses a configuration platform to define the properties of the connected DICOM SCP, e.g.:

- maximum number of print jobs in the queue
- maximum number of print copies
- supported film sizes of the connected DICOM SCP
- supported film formats of the DICOM SCP
- lookup table definition.

The printing is only suspended in the case of a failure return status of the SCP.

**11.1.2.1.3.1 Basic Film Session SOP class**

The Basic Film Session information object definition describes all the user-defined parameters, which are common for all the films of a film session. The Basic Film Session refers to one or more Basic Film Boxes, that are printed on one hardcopy printer.

The *syngo* DICOM print management SCU supports the following DIMSE Service elements for the Basic Film Session SOP Class as SCU:

- N-CREATE
- N-DELETE

The Basic Film Session SOP Class N-CREATE-RQ (SCU) uses the following attributes:

Attribute Name	Tag	Usage SCU	Supported Values
Number of Copies	(2000,0010)	U	1
Medium Type	(2000,0030)	U	BLUE FILM CLEAR FILM PAPER
Film Destination	(2000,0040)	U	MAGAZINE PROCESSOR

Table 37 Used Basic Film Session N-CREATE-RQ attributes

The number of Copies sent to the DICOM Printer is always 1, the job is sent n times for n copies.

The affected SOP Instance UID received with N-CREATE-RSP message will be kept internally and used for later requests (e.g. N-DELETE-RQ) on the Basic Film Session – see below:

Attribute Name	Tag	Source of Information
Requested SOP Instance UID	(0000,1000) → (0000,1001)	Affected SOP Instance UID of N-CREATE-RSP on Basic Film Session

Table 38 Attributes of N-DELETE-RQ on Basic Film Session SOP Class

The N-DELETE-RQ on the Basic Film Session SOP Class is used to remove the complete Basic Film Session SOP Instance hierarchy.

The Basic Film Session SOP class interprets the following status codes (from N-CREATE-RSP, N-DELETE-RSP messages):

Service Status	Meaning	Error Codes
Failed	Film session SOP instances hierarchy does not contain film box SOP instances	C600
	Unable to create print job, print queue is full	C601
	Image size is larger than images box size	C603
Warning	Memory allocation not supported	B600
	Film session printing is not supported	B601
	Film box does not contain image box (empty page)	B602
Success	Film belonging to the film session are accepted for printing	0000

Table 39 Basic Film Session SOP Status

### 11.1.2.1.3.2 Basic Film Box SOP class

The Basic Film Box information object definition describes all the user-defined parameters of one film of the film session. The Basic Film Box information description defines the presentation parameters, which are common for all images on a given sheet of film.

The Basic Film Box refers to one or more Image Boxes.

Supported Service Elements as SCU are:

- N-CREATE
- N-ACTION
- N-DELETE

The Basic Film Box SOP class N-CREATE-RQ message uses the following attributes (the actual values for each attribute depend on DICOM printer configuration within the *syngo* DICOM print management SCU):

Attribute Name	Tag	Usage SCU	Supported Values
Image Display Format	(2010,0010)	M	STANDARD\1,1
Referenced Film Session Sequence	(2010,0500)	M	
> Referenced SOP Class UID	(0008,1150)	M	1.2.840.10008.5.1.1.1
> Referenced SOP Instance UID	(0008,1155)	M	
Film Orientation	(2010,0040)	M	PORTRAIT
Film Size ID	(2010,0050)	M	8INX10IN, 10INX12IN, 10INX14IN, 11INX14IN,, 14INX14IN, 14INX17IN, 24CMX24CM, 24CMX30CM
Magnification Type	(2010,0060)	M	BILINEAR, CUBIC, NONE, REPLICATE
Border Density	(2010,0100)	U	BLACK, WHITE
Max Density	(2010,0130)	U	0 < Value
Min Density	(2010,0120)	U	0 < Value < 50
Illumination	(2010,015E)	U	0 < Value Required if Presentation LUT is present.
Reflective Ambient Light	(2010,0160)	U	0 < Value Required if Presentation LUT is present.
Referenced Presentation LUT Sequence	(2050,0500)	U	

Table 40 Used Film Box N-CREATE-RQ attributes

The N-CREATE-RSP message from the Print SCP includes the Referenced Image Box Sequence with SOP Class/Instance UID pairs which will be kept internally to be further used for the subsequent Basic Image Box SOP Class N-SET-RQ messages.

When all Image Boxes (including parameters) for the film-sheet have been set, the *syngo* DICOM print manager will issue a N-ACTION-RQ message with the SOP Instance UID of the Basic Film Box and the Action Type ID of 1.

The affected SOP Instance UID received with N-CREATE-RSP message will be kept internally and used for later requests (e.g. N-DELETE-RQ) on the Basic Film Box - see below:

Attribute Name	Tag	Source of Information
Requested SOP Instance UID	(0000,1000) → (0000,1001)	Affected SOP Instance UID of N-CREATE-RSP on Basic Film Box

Table 41 Attributes of N-DELETE-RQ on Basic Film Session SOP Class

The Basic Film Box SOP class interprets the following status codes:

Service Status	Meaning	Error Codes
Failure	Unable to create print job, print queue is full	C602
	Image size is larger than images box size	C603
Warning	Film box does not contain image box (empty page)	B603
	Requested MinDensity or MaxDensity outside of Printer's operating range	B605
Success	Film accepted for printing	0000

Table 42 Basic Film Session SOP Status

### 11.1.2.1.3.3 Basic Grayscale Image Box SOP Class

The Basic Grayscale Image Box information object definition is the presentation of an image and image related data in the image area of a film. The Basic Image Box information describes the presentation parameters and image pixel data, which apply to a single image of a sheet of film.

The Grayscale Image Box SOP Class uses only the N-SET-RQ with the following attributes:

Attribute Name	Tag	Usage SCU	Supported Values
Image Position	(2020,0010)	M	1
BASIC Grayscale Image Sequence	(2020,0110)	M	
> Samples per Pixel	(0028,0002)	M	1
> Photometric Interpretation	(0028,0004)	M	MONOCHROME2
> Rows	(0028,0010)	M	
> Columns	(0028,0011)	M	
> Pixel Aspect Ratio	(0028,0034)	M	
> Bits Allocated	(0028,0100)	M	8 or 16
> Bits Stored	(0028,0101)	M	8 or 12
> High Bit	(0028,0102)	M	7 or 11
> Pixel Representation	(0028,0103)	M	0
> Pixel Data	(7FE0,0010)	M	

Table 43 Mandatory Basic Grayscale Image Box N-SET attributes

The Grayscale Image Box SOP class interpret the following status codes:

Service Status	Meaning	Error Codes
Failure	Image contains more pixel than printer can print in Image Box	C603
	Insufficient memory in printer to store the image	C605
Warning	Requested MinDensity or MaxDensity outside of Printer's operating range	B605
Success		0000

Table 44 Basic Grayscale Image Box SOP Status

#### 11.1.2.1.3.4 Printer SOP Class

The Printer SOP Class is the possibility to monitor the status of the hardcopy printer in a synchronous and an asynchronous way.

The SCU uses the mandatory N-EVENT Report DIMSE service to monitor the changes of the printer status in an asynchronous way.

It can directly ask the Printer (SCP) for its status or receive Events from the Printer asynchronously:

- N-GET as SCU
- N-EVENT-REPORT as SCU In both cases the following information is supported:

Used Printer N-EVENT Report attributes

Event-type Name	Event	Attributes	Tag	Usage SCU
Normal	1			
Warning	2	Printer Status Info	(2110,0020)	U
Failure	3	Printer Status Info	(2110,0020)	U

Table 45 Used Printer N-EVENT report attributes

#### 11.1.2.1.3.4.1.1 Mandatory Printer N-GET-RSP, N-EVENT-REPORT-RQ attributes

Attribute Name	Tag	Usage SCP	Supported Values
Printer Status	(2110,0010)	M	NORMAL, FAILURE, WARNING
Printer Status Info	(2110,0020)	M	See tables in Annex for details.

Table 46 Mandatory Printer N-GET-RSP, N-EVENT-RQ attributes

**Note:** For a detailed description on how *syngo* reacts on different printer status messages, please refer to the Annex section "DICOM Print SCU – detailed status displays".

11.1.2.1.3.5 Print Job SOP Class

The Print Job SOP Class is the possibility to monitor the execution of the print process.

The *syngo* DICOM Print Management application supports the optional N-EVENT-REPORT DICMSE Service to receive the changes of the Print Job Status in an asynchronous way.

It can receive Events from the Print SCP asynchronously

Note: *syngo* does not support receiving N-EVENT from camera during print sessions, normally this is configurable in the camera.

N-EVENT-REPORT The following information is supported:

Event-type Name	Event	Attributes	Tag	Usage SCU
Normal	1	Execution Status Info	(2100,0030)	U
		Print Job ID	(2100,0010)	-- (Print Queue Management SOP Class not supported)
		Film Session Label	(2000,0050)	U
		Printer Name	(2110,0030)	U
Printing	2	Execution Status Info	(2100,0030)	U
		Print Job ID	(2100,0010)	-- (Print Queue Management SOP Class not supported)
		Film Session Label	(2000,0050)	U
		Printer Name	(2110,0030)	U
Done	3	Execution Status Info	(2100,0030)	U
		Print Job ID	(2100,0010)	-- (Print Queue Management SOP Class not supported)
		Film Session Label	(2000,0050)	U
		Printer Name	(2110,0030)	U
Failure	4	Execution Status Info	(2100,0030)	U
		Print Job ID	(2100,0010)	-- (Print Queue Management SOP Class not supported)
		Film Session Label	(2000,0050)	U
		Printer Name	(2110,0030)	U

Table 47 Used Print Job N-EVENT Report attributes

**Note:** For a detailed description on how *syngo* reacts on different printer status messages, please refer to the Annex section "DICOM Print SCU – detailed status displays".

11.1.3 Association Acceptance Policy

Not applicable

## 12 Implementation Model Worklist

The Basic Worklist Management Service class defines an application-level class of service that facilitates the transfer of worklists from the information system to the imaging modality. The worklist is queried by the AE and supplies the SCU with the scheduled tasks, which have to be performed on the modality. The AXIOM Artis VB22 DICOM worklist application supports the worklist service as SCU.

### 12.1 Application Data Flow Diagram

The AXIOM Artis VB22 DICOM network implementation acts as SCU for the Basic Worklist Service using the Modality Worklist SOP Class. The product target Operating System is Windows XP.

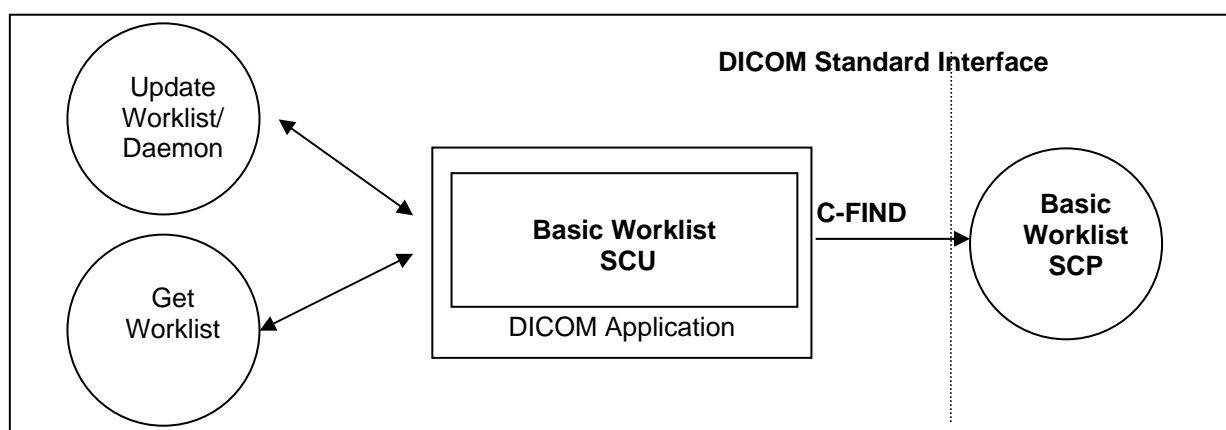

Figure 7 AXIOM Artis VB22 Application Flow Diagram – Basic Worklist SCU

### 12.2 Functional Definitions of Application Entities

The worklist SCU ("broad query") is invoked from the patient browser user interface or by timer to request the worklist from a remote Information System (Modality Worklist Class SCP). This is done to perform a match to the internal worklist query keys specified in the C-Find DIMSE service issued for the Modality Worklist Model.

The worklist SCP responses to the C-FIND query and scheduled imaging service requests (scheduled procedure steps) and patient demographic information will be downloaded from the information system to the AXIOM Artis VB22 modality. All information retrieved will be hold in the scheduling database for usage during Patient registration procedure.

Furthermore, the patient based Query dialog from the patient browser allows to enter specific matching criteria ("narrow query") for the worklist query. With the response data the Patient Registration dialog can be populated according availability within the worklist response identifier.

**12.3 Sequencing of Real-World Activities**

The “narrow” (interactive) Worklist Query requires that sufficient matching keys or a unique matching key are/is entered before the query is issued. Only then a single response can be expected to complete the registration dialog.

## 13 Application Entity Specification Worklist

### 13.1 Modality Worklist Service AE Specification

The Modality worklist SCU (patient registration in conjunction with the network application) requests that the remote SCP performs a match of all keys specified in the query against the information in its worklist database.

The AXIOM Artis VB22 DICOM network implementation acts as SCU for the Basic Worklist Service using the Modality Worklist SOP Class:

SOP Class Name	SOP Class UID
Modality Worklist Information Model - FIND	1.2.840.10008.5.1.4.31

Table 48 SOP Classes as a SCU

#### 13.1.1 Association Establishment Policies

##### 13.1.1.1 General

It is possible to configure a cyclic update of the modality scheduler database through a background worklist request with date/time and modality information.

In addition, the user can request worklist update with "Update Worklist". No duplicate entries will be added in the Scheduler DB. Entries are uniquely identified by the Study Instance UID (0020,000D) for the Requested Procedure and the SPS ID (0040,009) in the SPS Sequence (0040,0100).

An interactive worklist query can be issued with search criteria entered in the patient based Query dialog from the patient browser.

The default PDU size used will be 256 KB.

##### 13.1.1.2 Number of Associations

The AXIOM Artis VB22 DICOM application initiates one association at a time to query worklist entry data.

##### 13.1.1.3 Asynchronous Nature

The AXIOM Artis VB22 DICOM software does not support asynchronous communication (multiple outstanding transactions over a single association).

##### 13.1.1.4 Implementation Identifying Information

Implementation Class UID	1.3.12.2.1107.5.5.9.20000101
Implementation Version Name	SIEMENS_SWFVX47A

Table 49 Implementation Identifying Information

**13.1.2 Association Initiation Policy**

The network application will cyclically query the worklist provider and by request from the patient registration interface. It establishes an association by using the DICOM association services. During association establishment the negotiation of SOP classes to exchange the capabilities of the SCU and the SCP is not supported.

The following DIMSE-C operation is supported as SCU:

- C-FIND

**13.1.2.1 Real-World Activity**

**13.1.2.1.1 Associated Real-World Activity - Query (Update) Worklist**

A network application will perform worklist queries with the C-FIND request at regular intervals. In addition it can be triggered by immediate request. The received worklist items will be compared with the contents of the local scheduler database. New items will be inserted into scheduler database.

After each broad-query, all RP/SPS that were canceled or rescheduled to another modality at the RIS will be automatically removed from the Scheduler DB if :

1. the Examination of this procedure has not been started or finished yet, and
2. the corresponding configuration item “Automatic removal of canceled/rescheduled Request” was checked in the Service UI under DICOM/HIS-RIS Node.

No automatic clean-up of the scheduler DB is performed after a Patient base Query since the worklist received does not give the complete list of all currently scheduled procedures for the modality.

**13.1.2.1.2 Proposed Presentation Contexts**

The AXIOM Artis VB22 DICOM application will propose Presentation Contexts as shown in the following table:

Presentation Context Table					
Abstract Syntax		Transfer Syntax		Role	Ext. Neg.
Name	UID	Name List	UID List		
Modality Worklist Information Model- FIND	1.2.840.10008.5.1.4.31	Implicit VR Little Endian Explicit VR Little Endian Explicit VR Big Endian	1.2.840.10008.1.2 1.2.840.10008.1.2.1 1.2.840.10008.1.2.2	SCU	None

Table 50 Proposed Presentation Contexts

**13.1.2.1.3 SOP Specific Conformance Statement**

- Search Key Attributes of the Worklist C-FIND

The AXIOM Artis VB22 DICOM worklist SCU supports “broad worklist queries” with all required search keys. The following tables describe the “broad query” search keys that the SCU supports.

Attribute Name	Tag	Matching Key Type	Query Value
Scheduled Procedure Step			
Scheduled Procedure Step Sequence	(0040,0100)	R	
>Scheduled Station AE Title <i>(This depends on user configuration (Options-&gt;Configuration-&gt;Patient Registration) if the "own AET" is provided or not. Use the "HIS/RIS" tab card for configuration.)</i>	(0040,0001)	R	<own AET> or <zero length>
>Scheduled Procedure Step Start Date <i>(It depends on user configuration (Options-&gt;Configuration-&gt;Patient Registration) if the actual Date with a full time range or an interactive input dialog for date/time specification is used.)</i>	(0040,0002)	R	<act. Date>-<act. Date> or range from UI
>Scheduled Procedure Step Start Time <i>(It depends on user configuration (Options-&gt;Configuration-&gt;Patient Registration) if the actual Date with a full time range or an interactive input dialog for date/time specification is used.)</i>	(0040,0003)	R	00.00-235959.00 or range from UI
>Modality <i>(This depends on user configuration (Options-&gt;Configuration-&gt;Patient Registration) if the "own Modality" is provided or not. Use the "HIS/RIS" tabcard for configuration.)</i>	(0008,0060)	R	<zero length> or <own Modality>
>Scheduled Performing Physician	(0040,0006)	R	NULL

Table 51 Supported Broad Worklist Query Search Key Attributes

- Return Key Attributes of the Worklist C-FIND

The AXIOM Artis VB22 DICOM worklist SCU supports worklist queries with return key attributes of all types. The following tables describe the return keys that the SCU supports.

An “x” in the **UI** column will indicate the attribute is visualized when browsing the Worklist results with Patient Browser and/or during Patient Registration. The Patient Browser display is additionally influenced by the related Browser configuration.

A tag in the **IOD** column will indicate that the related attribute is included into the SOP Instances of the IODs created during processing of this worklist request.

A tag in the **MPPS** column will indicate that the related attribute is included into the SOP Instances of the MPPS objects created during processing of this worklist request. ( See also the tables “Attributes used for the Performed Procedure Step N-CREATE” and “Attributes used for the Performed Procedure Step N-SET”.)

Attribute Name	Tag	Return Key Type	UI	IOD	MPPS
<b>SOP Common</b>					
Specific Character Set	(0008,0005)	1C	-	(0008,0005)	(0008,0005)
<b>Scheduled Procedure Step</b>					
Scheduled Procedure Step Sequence	(0040,0100)	1			
>Modality	(0008,0060)	1	x	(0008,0060)	(0008,0060)
>Requested Contrast Agent	(0032,1070)	2C	x	(0032,1070)	
>Scheduled Station AE Title <i>(“Scheduled Station AE Title” is taken as default for “Performed Station AE Title”)</i>	(0040,0001)	1	x		(0040,0241)
>Scheduled Procedure Step Start Date	(0040,0002)	1	x		
>Scheduled Procedure Step Start Time	(0040,0003)	1	x		
>Scheduled Procedure Step End Date	(0040,0004)	3	-		
>Scheduled Procedure Step End Time	(0040,0005)	3	-		

Attribute Name	Tag	Return Key Type	UI	IOD	MPPS
>Scheduled Performing Physician's Name ( <i>"Scheduled Performing Physician's Name" is taken as default for "Performing Physician's Name"</i> )	(0040,0006)	1	x	(0008,1050)	(0008,1050)
>Scheduled Procedure Step Description ( <i>"Scheduled Procedure Step Description" is taken as default for "Performed Procedure Step Description"</i> )	(0040,0007)	1C	x	(0040,0007) (0040,0254)	(0040,0007) (0040,0254)
>Scheduled Protocol Code Sequence ( <i>universal Sequence Match</i> ) ( <i>"Scheduled Protocol Code Sequence" is taken as default for "Performed Protocol Code Sequence"</i> )	(0040,0008)	1C	-	(0040,0008) (0040,0260)	(0040,0008) (0040,0260)
>>Code Value	(0008,0100)	1C	x		
>>Coding Scheme Designator	(0008,0102)	1C	x		
>>Coding Scheme Version	(0008,0103)	3	x		
>>Code Meaning	(0008,0104)	3	x		
>Scheduled Procedure Step ID ( <i>"Scheduled Procedure Step ID" is taken as default for "Performed Procedure Step ID"</i> )	(0040,0009)	1	x	(0040,0009) (0040,0253)	(0040,0009) (0040,0253)
>Scheduled Station Name	(0040,0010)	2	x		
>Scheduled Procedure Step Location ( <i>"Scheduled Procedure Step Location" is taken as default for "Performed Location"</i> )	(0040,0011)	2	x		(0040,0242)
>Pre-Medication	(0040,0012)	2C	x		
>Scheduled Procedure Step Status	(0040,0020)	3	x		
>Comments on the Scheduled Procedure Step	(0040,0400)	3	-		
<b>Requested Procedure</b>					
Referenced Study Sequence ( <i>universal Sequence Match</i> )	(0008,1110)	2	-	(0008,1110)	(0008,1110)
>Referenced SOP Class UID	(0008,1150)	1C	-		
>Referenced SOP Instance UID	(0008,1155)	1C	-		
Study Instance UID	(0020,000D)	1	-	(0020,000D)	(0020,000D)
Requested Procedure Description	(0032,1060)	1C	x	(0032,1060)	(0032,1060)
Requested Procedure Code Sequence ( <i>universal Sequence Match</i> ) ( <i>"Requested Procedure Code Sequence" is taken as default for "Procedure Code Sequence"</i> )	(0032,1064)	1C	-	(0008,1032) (0032,1064)	(0008,1032)
>Code Value	(0008,0100)	1C	x		
>Coding Scheme Designator	(0008,0102)	1C	x		
>Coding Scheme Version	(0008,0103)	3	x		
>Code Meaning	(0008,0104)	3	x		
Requested Procedure ID ( <i>"Requested Procedure ID" is taken as default for "Study ID"</i> )	(0040,1001)	1	x	(0040,1001) (0020,0010)	(0040,1001) (0020,0010)
Reason for the Requested Procedure	(0040,1002)	3	-		
Requested Procedure Priority	(0040,1003)	2	x		
Patient Transport Arrangements	(0040,1004)	2	-		
Requested Procedure Location	(0040,1005)	3	-		
Confidentiality Code	(0040,1008)	3	-		
Reporting Priority	(0040,1009)	3	-		
Names of intended Recipients of Results	(0040,1010)	3	-	(0008,1048)	
Requested Procedure Comments	(0040,1400)	3	x		
<b>Imaging Service Request</b>					
Accession Number	(0008,0050)	2	x	(0008,0050)	(0008,0050)
Referring Physician's Name	(0008,0090)	2	x	(0008,0090)	
Requesting Physician	(0032,1032)	2	x	(0032,1032)	(0032,1032)
Requesting Service	(0032,1033)	3	x	(0032,1033)	
Reason for the Imaging Service Request	(0040,2001)	3	-		
Issuing Date of Imaging Service Request	(0040,2004)	3	-		
Issuing Time of Imaging Service Request	(0040,2005)	3	-		

Attribute Name	Tag	Return Key Type	UI	IOD	MPPS
Placer Order Number / Imaging Service Request <i>(Old tag (0040,2006) is retired and not used.)</i>	(0040,2016)	3	-		(0040,2016)
Filler Order Number / Imaging Service Request <i>(Old tag (0040,2007) is retired and not used.)</i>	(0040,2017)	3	-		(0040,2017)
Order entered by ...	(0040,2008)	3	-		
Order Enterer's location	(0040,2009)	3	-		
Order Callback Phone Number	(0040,2010)	3	-		
Imaging Service Request Comments	(0040,2400)	3	x		
<b>Visit Identification</b>					
Institution Name	(0008,0080)	3	x	(0008,0080)	
Institution Address	(0008,0081)	3	-	(0008,0081)	
Institution Code Sequence <i>(universal Sequence Match)</i>	(0008,0082)	3	-		
>Code Value	(0008,0100)	1C	-		
>Coding Scheme Designator	(0008,0102)	1C	-		
>Coding Scheme Version	(0008,0103)	3	-		
>Code Meaning	(0008,0104)	3	-		
Admission ID	(0038,0010)	2	x		
Issuer of Admission ID	(0038,0011)	3	-		
<b>Visit Status</b>					
Visit Status ID	(0038,0008)	3	-		
Current Patient Location	(0038,0300)	2	x		
Patient's Institution Residence	(0038,0400)	3	-		
Visit Comments	(0038,4000)	3	-		
<b>Visit Relationship</b>					
Referenced Study Sequence <i>(universal Sequence Match)</i>	(0008,1110)	3	-		
>Referenced SOP Class UID	(0008,1150)	1C	-		
>Referenced SOP Instance UID	(0008,1155)	1C	-		
Referenced Patient Sequence <i>(universal Sequence Match)</i>	(0008,1120)	2	-		(0008,1120)
>Referenced SOP Class UID	(0008,1150)	1C	-		
>Referenced SOP Instance UID	(0008,1155)	1C	-		
<b>Visit Admission</b>					
Referring Physician's Name	(0008,0090)	2	x	(0008,0090)	
Referring Physician's Address	(0008,0092)	3	-		
Referring Physician's Phone Numbers	(0008,0094)	3	-		
Admitting Diagnosis Description	(0008,1080)	3	x	(0008,1080)	
Admitting Diagnosis Code Sequence <i>(universal Sequence Match)</i>	(0008,1084)	3	-		
>Code Value	(0008,0100)	1C	-		
>Coding Scheme Designator	(0008,0102)	1C	-		
>Coding Scheme Version	(0008,0103)	3	-		
>Code Meaning	(0008,0104)	3	-		
Route of Admissions	(0038,0016)	3	-		
Admitting Date	(0038,0020)	3	-		
Admitting Time	(0038,0021)	3	-		
<b>Patient Identification</b>					
Patient's Name	(0010,0010)	1	x	(0010,0010)	(0010,0010)
Patient ID	(0010,0020)	1	x	(0010,0020)	(0010,0020)
Issuer of Patient ID	(0010,0021)	3	-	(0010,0021)	
Other Patient IDs	(0010,1000)	3	x	(0010,1000)	
Other Patient Names	(0010,1001)	3	x	(0010,1001)	
Patient's Birth Name	(0010,1005)	3	-	(0010,1005)	
Patient's Mother's Birth Name	(0010,1060)	3	-	(0010,1060)	

Attribute Name	Tag	Return Key Type	UI	IOD	MPPS
Medical Record Locator	(0010,1090)	3	-	(0010,1090)	
<b>Patient Demographic</b>					
Patient's Birth Date	(0010,0030)	2	x	(0010,0030)	(0010,0030)
Patient's Birth Time	(0010,0032)	3	-	(0010,0032)	
Patient's Sex	(0010,0040)	2	x	(0010,0040)	(0010,0040)
Patient's Insurance Plan Code Sequence ( <i>universal Sequence Match</i> )	(0010,0050)	3	-	(0010,0050)	
>Code Value	(0008,0100)	1C	-		
>Coding Scheme Designator	(0008,0102)	1C	-		
>Coding Scheme Version	(0008,0103)	3	-		
>Code Meaning	(0008,0104)	3	-		
Patient's Age	(0010,1010)	3	x	(0010,1010)	
Patient's Size	(0010,1020)	3	x	(0010,1020)	
Patient's Weight	(0010,1030)	2	x	(0010,1030)	
Patient's Address	(0010,1040)	3	x	(0010,1040)	
Military Rank	(0010,1080)	3	x	(0010,1080)	
Branch of Service	(0010,1081)	3	-	(0010,1081)	
Country of Residence	(0010,2150)	3	-	(0010,2150)	
Region of Residence	(0010,2152)	3	-	(0010,2152)	
Patient's Telephone Numbers	(0010,2154)	3	-	(0010,2154)	
Ethnic Group	(0010,2160)	3	x	(0010,2160)	
Occupation	(0010,2180)	3	-	(0010,2180)	
Patient's Religious Preference	(0010,21F0)	3	-	(0010,21F0)	
Patient Comments	(0010,4000)	3	x	(0010,4000)	
Patient Data Confidentiality Constraint Description	(0040,3001)	2	x	(0040,3001)	
<b>Patient Medical</b>					
Medical Alerts	(0010,2000)	2	x	(0010,2000)	
Contrast Allergies	(0010,2110)	2	x	(0010,2110)	
Pregnancy Status	(0010,21C0)	2	x	(0010,21C0)	
Smoking Status	(0010,21A0)	3	x	(0010,21A0)	
Last Menstrual Date	(0010,21D0)	3	x	(0010,21D0)	
Additional Patient History	(0010,21B0)	3	x	(0010,21B0)	
Special Needs	(0038,0050)	2	x	(0038,0050)	
Patient State	(0038,0500)	2	x	(0038,0500)	
<b>Patient Relationship</b>					
Referenced Study Sequence ( <i>universal Sequence Match</i> )	(0008,1110)	3	-		
>Referenced SOP Class UID	(0008,1150)	1C	-		
>Referenced SOP Instance UID	(0008,1155)	1C	-		
Referenced Visit Sequence ( <i>universal Sequence Match</i> )	(0008,1125)	3	-		
>Referenced SOP Class UID	(0008,1150)	1C	-		
>Referenced SOP Instance UID	(0008,1155)	1C	-		
Referenced Patient Alias Sequence ( <i>universal Sequence Match</i> )	(0038,0004)	3	-		
>Referenced SOP Class UID	(0008,1150)	1C	-		
>Referenced SOP Instance UID	(0008,1155)	1C	-		

Table 52 Basic Worklist C-FIND-RSP Return Key Attributes

**Note on Specific Character Set (0008,0005)**

If the C-FIND-RQ does not contain "specific characters", 0008,0005 will not be part of the C-FIND-RQ. If, however, the C-FIND-RSP contains "specific characters" in any of the Return Keys, it is expected, that 0008,0005 is part of the C-FIND-RSP from the MWL SCP.

**13.1.2.1.4 Associated Real-World Activity – Get Worklist**

With "Get Worklist" in the patient based Worklist Query dialog, the entered attributes are used to form a worklist request identifier. With the response data the Patient Registration dialog can be updated to perform examination in advance. The response data are additionally placed in the scheduler database.

**13.1.2.1.5 Proposed Presentation Contexts – Get Worklist**

This RWA will propose the same Presentation Contexts as with "Update Worklist". Please see table in section 13.1.2.1.2.

**13.1.2.1.6 SOP Specific Conformance – Get Worklist**

**13.1.2.1.6.1 Search Key Attributes of the Worklist C-FIND**

The AXIOM Artis VB22 DICOM worklist SCU supports "narrow worklist queries" with all required search keys. The following tables describe the "narrow query" search keys that the SCU supports.

Attribute Name	Tag	Matching Key Type	Query Value
Scheduled Procedure Step			
Scheduled Procedure Step Sequence	(0040,0100)	R	
>Scheduled Performing Physician's Name	(0040,0006)	R	input from UI or <zero length>
Requested Procedure			
Requested Procedure ID	(0040,1001)	O	input from UI or <zero length>
Imaging Service Request			
Accession Number	(0008,0050)	O	input from UI or <zero length>
Referring Physician's Name	(0008,0090)	O	input from UI or <zero length>
Visit Status			
Current Patient Location	(0038,0300)	O	input from UI or <zero length>
Patient Identification			
Patient's Name	(0010,0010)	R	input from UI or <zero length>
Patient ID	(0010,0020)	R	input from UI or <zero length>

Table 53 Patient based "narrow query" Search Key Attributes

**13.1.2.1.6.2 Return Key Attributes of the Worklist C-FIND**

Please see list for "Update Worklist" RWA.

13.1.2.1.6.3 Status Codes of the Worklist C-FIND

The worklist SCU interprets following status codes:

Service Status	Meaning	Error Codes	Related Fields
Refused	Out of Resources	A700	(0000,0902)
Failed	Identifier does not match SOP Class	A900	(0000,0901) (0000,0902)
	Unable to process	Cxxx	(0000,0901) (0000,0902)
Cancel	Matching terminated due to Cancel request	FE00	None
Success	Matching is complete - No final Identifier is supplied	0000	None
Pending	Matches are continuing - Current Match is supplied and any Optional Keys were supported in the same manner as Required Keys	FF00	Identifier
	Matches are continuing - Warning that one or more Optional Keys were not supported for existence and/or matching for this identifier	FF01	Identifier

Table 54 C-FIND-RSP Status

## 14 Implementation Model MPPS

The Modality Performed Procedure Step Service class defines an application-level class of service that facilitates the transfer of procedure, billing and radiation dose information from the imaging modality to the information system. The Performed Procedure Step is created and set by the AE and supplies the SCP with the information about a real-world procedure which is performed on the modality. The AXIOM Artis VB22 DICOM Modality Performed Procedure Step application supports the MPPS service as SCU.

### 14.1 Application Data Flow Diagram

The AXIOM Artis VB22 DICOM network implementation acts as SCU for the Modality Performed Procedure Step SOP Class. The product target Operating System is Windows XP.

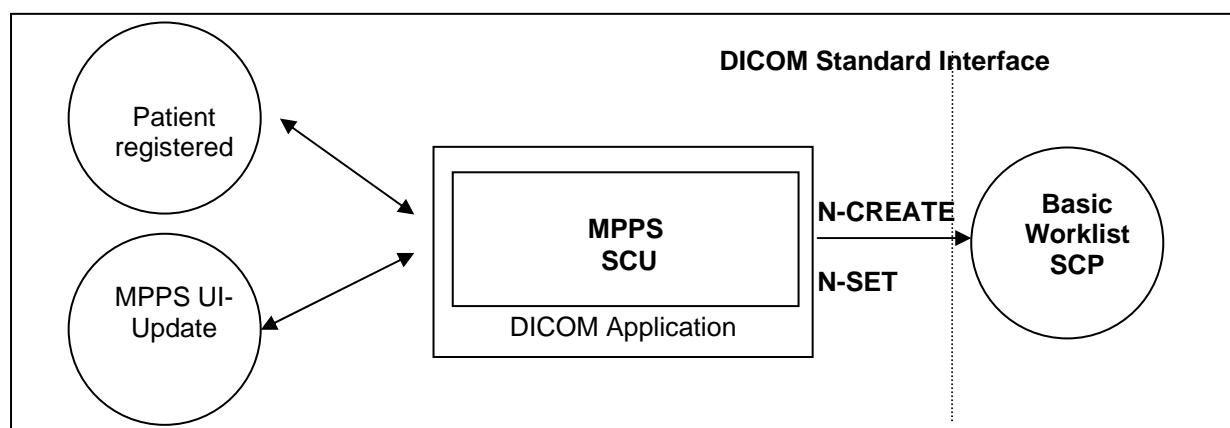

Figure 8 AXIOM Artis VB22 Application Flow Diagram – MPPS SCU

### 14.2 Functional Definitions of Application Entities

With registering a Patient (i.e. a Scheduled Procedure Step from Worklist), the AXIOM Artis VB22 DICOM application will create a MPPS Instance and communicate it to the MPPS SCP.

It is configurable to set the states of all related MPPS to "Completed" when a patient is closed. Furthermore, a manual update can be performed with the AXIOM Artis VB22 MPPS user interface. From the user interface it is possible to set the state of the MPPS to "Completed" or "Discontinued". After that the DICOM application will no longer allow updates on the related MPPS Instance.

The AXIOM Artis VB22 will not only allow a "1:1 -relationship" of Scheduled Procedure Steps and Performed Procedure Steps, but also supports the "simple group-case" (grouping several SPS of the same Requested Procedure), "complex group-case" (grouping several SPS from different Requested Procedures) and "append case" from the respective IHE-scenarios.

The AXIOM Artis VB22 will support creation of "unscheduled cases" by allowing MPPS Instances to be communicated for locally registered Patients.

### 14.3 Sequencing of real World Activities

An MPPS Update is only possible, if the MPPS Instance was created with Patient Registration before.

## 15 AE Specification MPPS

### 15.1 Modality Performed Procedure Step AE Specification

The Modality Performed Procedure Step SCU (Patient Registration and MPPS UI) provide information about a performed real-world Procedure to a remote SCP (Information System).

SIEMENS AXIOM Artis VB22 DICOM products provide Standard Conformance to the following DICOM V3.0 SOP Class as an SCU:

SOP Class Name	SOP Class UID
Modality Performed Procedure Step	1.2.840.10008.3.1.2.3.3

Table 55 SOP Classes as an SCU

#### 15.1.1 Association Establishment Policies

##### 15.1.1.1 General

The creation of MPPS Instance is done automatically by AXIOM Artis VB22 whenever a patient is registered for image acquisition through the Patient Registration dialog.

Further updates on the MPPS data can be done interactively from the related MPPS user interface. The MPPS “Complete” or “Discontinued” states can only be set from user interface.

The default PDU size used will be 256 KB.

##### 15.1.1.2 Number of Associations

The AXIOM Artis VB22 DICOM application initiates one association at a time to create or set MPPS instance.

##### 15.1.1.3 Asynchronous Nature

The AXIOM Artis VB22 DICOM software does not support asynchronous communication (multiple outstanding transactions over a single association).

##### 15.1.1.4 Implementation Identifying Information

Implementation Class UID	1.3.12.2.1107.5.5.9.20000101
Implementation Version Name	“SIEMENS_SWFVX47A”

Table 56 Implementation Identifying Information

#### 15.1.2 Association Initiation Policy

The AXIOM Artis VB22 DICOM Application Entity acts as a Service Class User (SCU) for the

- Modality Performed Procedure Step Service Class (to notify a RIS about status of a procedure while it is performed).

To do so, the AXIOM Artis VB22 will issue a

- N-CREATE DIMSE according to the CREATE Modality Performed Procedure Step SOP Instance operation or a
- N-SET DIMSE to update the contents and state of the MPPS according to the SET Modality Performed Procedure Step Information operation.

**15.1.2.1 Real World Activity**

**15.1.2.1.1 Associated Real-World Activity - Patient registered**

A patient is registered by the Patient Registration “Exam” action. From this event the trigger to create a MPPS Instance is derived. The related Instance is then immediately communicated to the configured RIS system. An association is established and the MPPS Instance is sent.

**15.1.2.1.2 Proposed Presentation Contexts - Patient registered**

The AXIOM Artis VB22 DICOM application will propose Presentation Contexts as shown in the following table:

Presentation Context Table					
Abstract Syntax		Transfer Syntax		Role	Ext. Neg.
Name	UID	Name List	UID List		
Modality Performed Procedure Step	1.2.840.10008.3.1.2.3.3	Implicit VR Little Endian Explicit VR Little Endian Explicit VR Big Endian	1.2.840.10008.1.2 1.2.840.10008.1.2.1 1.2.840.10008.1.2.2	SCU	None

Table 57 Proposed Presentation Contexts - MPPS

**15.1.2.1.3 SOP Specific Conformance Statement- Patient registered**

**15.1.2.1.3.1 Attributes used for the Performed Procedure Step N-CREATE**

The Siemens AXIOM Artis VB22 DICOM Modality Performed Procedure Step SCU informs the remote SCP when the examination of a scheduled procedure step will be performed (i.e. the patient is registered). The N-CREATE message is sent when the examination is started with successful registration of the patient data. The following table describes the supported attributes of a N-CREATE message.

Attribute Name	Tag	Type	Value
SOP Common			
Specific Character Set	(0008,0005)	1C	from MWL or created
Performed Procedure Step Relationship			
Scheduled Step Attribute Sequence	(0040,0270)	1	
>Study Instance UID	(0020,000D)	1	from MWL or created
>Referenced Study Sequence	(0008,1110)	2	from MWL or <zero length>
>>Referenced SOP Class UID	(0008,1150)	1C	
>>Referenced SOP Instance UID	(0008,1155)	1C	
>Accession Number	(0008,0050)	2	from MWL or user input
>Placer Order Number/Imaging Service Request	(0040,2016)	3	from MWL or <zero length>
>Filler Order Number/Imaging Service Request	(0040,2017)	3	from MWL or <zero length>
>Requested Procedure ID	(0040,0001)	2	from MWL or user input
>Requested Procedure Description	(0032,1060)	2	from MWL or <zero length>

Attribute Name	Tag	Type	Value
>Scheduled Procedure Step ID	(0040,0009)	2	from MWL or <zero length>
>Scheduled Procedure Step Description	(0040,0007)	2	from MWL or <zero length>
>Scheduled Protocol Code Sequence	(0040,0008)	2	from MWL or <zero length>
>>Code Value	(0008,0100)	1C	
>>Coding Scheme Designator	(0008,0102)	1C	
>>Coding Scheme Version	(0008,0103)	3	
>>Code Meaning	(0008,0104)	3	
Patient's Name	(0010,0010)	2	from MWL or user input
Patient ID	(0010,0020)	2	from MWL or user input
Patient's Birth Date	(0010,0030)	2	from MWL or user input
Patient's Sex	(0010,0040)	2	from MWL or user input
Referenced Patient Sequence	(0008,1120)	2	from MWL or <zero length>
>Referenced SOP Class UID	(0008,1150)	1C	
>Referenced SOP Instance UID	(0008,1155)	1C	
<b>Performed Procedure Step Information</b>			
Performed Procedure Step ID	(0040,0253)	1	From SPS ID or created
Performed Station AE Title	(0040,0241)	1	own AE Title
Performed Station Name	(0040,0242)	2	own hostname
Performed Location	(0040,0243)	2	from SPS location or <zero length>
Performed Procedure Step Start Date	(0040,0244)	1	created
Performed Procedure Step Start Time	(0040,0245)	1	created
Performed Procedure Step Status	(0040,0252)	1	"IN PROGRESS"
Performed Procedure Step Description	(0040,0254)	2	from SPS Description or <zero length>
Performed Procedure Type Description	(0040,0255)	2	<zero length>
Procedure Code Sequence	(0008,1032)	2	from Requested Procedure Code or <zero length>
>Code Value	(0008,0100)	1C	
>Coding Scheme Designator	(0008,0102)	1C	
>Coding Scheme Version	(0008,0103)	3	
>Code Meaning	(0008,0104)	3	
Performed Procedure Step End Date	(0040,0250)	2	<zero length>
Performed Procedure Step End Time	(0040,0251)	2	<zero length>
Comments on the Performed Procedure Steps	(0040,0280)	3	<zero length>
<b>Image Acquisition Results</b>			
Modality	(0008,0060)	1	XA
Study ID	(0020,0010)	2	from Requested Procedure ID or created
Performed Protocol Code Sequence	(0040,0260)	2	from Scheduled Protocol Code Sequence or <zero length>
>Code Value	(0008,0100)	1C	
>Coding Scheme Designator	(0008,0102)	1C	
>Coding Scheme Version	(0008,0103)	3	
>Code Meaning	(0008,0104)	3	
Performed Series Sequence	(0040,0340)	2	
>Performing Physician's Name	(0008,1050)	2C	from MWL or user input
>Operator's Name	(0008,1070)	2C	User input
>Series Instance UID	(0020,000E)	1C	created
>Series Description	(0008,103E)	2C	<zero length>
>Retrieve AE Title	(0008,0054)	2C	<zero length>
>Protocol Name	(0018,1030)	1C	from organ program
>Referenced Image Sequence	(0008,1140)	2C	<zero length>
>Referenced Non-Image Composite SOP Instance Sequence	(0040,0220)	2C	<zero length>
<b>Radiation Dose</b>			

Anatomic Structure, Space or Region Sequence	(0008,2229)	3	<zero length>
Attribute Name	Tag	Type	Value
Total Time of Fluoroscopy	(0040,0300)	3	<zero length>
Total Number of Exposures	(0040,0301)	3	<zero length>
Distance Source to Detector	(0018,1110)	3	<zero length>
Distance Source to Entrance	(0040,0306)	3	<zero length>
Entrance Dose	(0040,0302)	3	<zero length>
Exposed Area	(0040,0303)	3	<zero length>
Image Area Dose Product	(0018,115E)	3	<zero length>
Comments on Radiation Dose	(0040,0310)	3	<zero length>
Billing and Material Management Code			
Billing Procedure Step Sequence	(0040,0320)	3	<zero length>
Film Consumption Sequence	(0040,0321)	3	
>Number of Films	(2100,0170)	3	<zero length>
>Medium Type	(2000,0030)	3	<zero length>
>Film Size ID	(2010,0050)	3	<zero length>
Billing Supplies and Devices Sequence	(0040,0324)	3	
>Billing Item Sequence	(0040,0296)	3	<zero length>
>Quantity Sequence	(0040,0293)	3	
>>Quantity	(0040,0294)	3	<zero length>
>>Measuring Units Sequence	(0040,0295)	3	<zero length>

Table 58 Performed Procedure Step N-CREATE Attributes

### 15.1.2.1.3.2 Status Codes of the Performed Procedure Step N-CREATE

The Performed Procedure Step SCU interprets following status codes:

Service Status	Meaning	Error Codes (0000.0900)
Failure	Processing Failure	0110
	No such attribute	0105
	Invalid attribute value	0106
	Duplicate SOP Instance	0111
	No such SOP Instance	0112
	No such SOP Class	0118
	Class Instance conflict	0119
	Missing attribute	0120
	Missing attribute value	0121
	Resource limitation	0213
Success	MPPS Instance created	0000

Table 59 MPPS N-CREATE Response Status

### 15.1.2.1.4 Associated Real-World Activity – MPPS UI-Update

With the MPPS UI the status of the MPPS Instance can be set to “COMPLETED” or “DISCONTINUED”. During performance of the procedure the status will remain “IN PROGRESS”.

### 15.1.2.1.5 Proposed Presentation Contexts – MPPS UI-Update

This RWA will propose the same Presentation Contexts as with “Patient registered”. Please see table in section 15.1.2.1.2.

### 15.1.2.1.6 SOP Specific Conformance Statement – MPPS UI-Update

15.1.2.1.6.1 Attributes used for the Performed Procedure Step N-SET

The Siemens AXIOM Artis VB22 DICOM Modality Performed Procedure Step SCU informs the remote SCP about the performed examination and its status. The N-SET message is sent after each acquisition (status "IN PROGRESS") and per finished examination (finished status "COMPLETED" or incomplete status "DISCONTINUED"). The following table describes the supported attributes of a N-SET message.

Attribute Name	Tag	Type	Value
<b>Performed Procedure Step Information</b>			
Performed Procedure Step Status	(0040,0252)	3	"IN PROGRESS" during procedure, "COMPLETED" or "DISCONTINUED" for final N-SET
Performed Procedure Step Description	(0040,0254)	3	from SPS Description or user input
Performed Procedure Type Description	(0040,0255)	3	User input
Procedure Code Sequence	(0008,1032)	3	from Requested Procedure
>Code Value	(0008,0100)	1C	
>Coding Scheme Designator	(0008,0102)	1C	
>Coding Scheme Version	(0008,0103)	3	
>Code Meaning	(0008,0104)	3	
Performed Procedure Step End Date	(0040,0250)	1	created
Performed Procedure Step End Time	(0040,0251)	1	created
<b>Image Acquisition Results</b>			
Performed Protocol Code Sequence	(0040,0260)	3	from Scheduled Protocol Code Sequence
>Code Value	(0008,0100)	1C	
>Coding Scheme Designator	(0008,0102)	1C	
>Coding Scheme Version	(0008,0103)	3	
>Code Meaning	(0008,0104)	3	
Performed Series Sequence	(0040,0340)	1	
>Performing Physician's Name	(0008,1050)	2C	from MWL or user input
>Protocol Name	(0018,1030)	1C	from related SOP Instance
>Operator's Name	(0008,1070)	2C	user input
>Series Instance UID	(0020,000E)	1C	from related SOP Instance
>Series Description	(0008,103E)	2C	from related SOP Instance
>Retrieve AE Title	(0008,0054)	2C	
>Referenced Image Sequence	(0008,1140)	2C	Series related SOP Instances as items
>>Referenced SOP Class UID	(0008,1150)	1C	
>>Referenced SOP Instance UID	(0008,1155)	1C	
>Referenced Standalone SOP Instance Sequence	(0040,0220)	2C	<zero length>
<b>Radiation Dose</b>			
Total Number of Exposures	(0040,0301)	3	
Distance Source to Detector	(0018,1110)	3	
Image Area Dose Product	(0018,115E)	3	
<b>Billing and Material Management Code</b>			
Film Consumption Sequence	(0040,0321)	3	
>Number of Films	(2100,0170)	3	<zero length>
>Medium Type	(2000,0030)	3	<zero length>
>Film Size ID	(2010,0050)	3	<zero length>

Table 60 Performed Procedure Step N-SET Attributes

15.1.2.1.6.2 Status Codes of the Performed Procedure Step N-SET

The Performed Procedure Step SCU interprets following status codes:

Service Status	Meaning	Error Codes (0000.0900)
Failure	Processing Failure: Performed Procedure Step Object may no longer be updated.	0110
	No such attribute	0105
	Invalid attribute value	0106
	No such SOP Instance	0112
	Invalid Object instance	0117
	No such SOP Class	0118
	Class Instance conflict	0119
	Missing attribute value	0121
	Resource limitation	0213
Success	MPPS Instance set	0000

Table 61 MPPS N-SET Response Status

15.1.2.1.6.3 Performed Procedure Step ID without MPPS

Handling of Performed Procedure Step ID in case

- MPPS is not configured or
- Unscheduled case

The attribute "Performed Procedure Step ID" (0040,0235) will be encoded based on "YYYYMMDDHHMMSS". This date and time is based on the time when the first image is acquired. The "Performed Procedure Step ID" stays the same for all acquired or derived images as long as the patient is re-registered. A re-registered patient with a new study or new series within the existing study will get a newly assigned "Performed Procedure Step ID".

## **16 Communication Profiles**

### **16.1 Supported Communication Stacks**

The Siemens AXIOM Artis VB22 DICOM application provides DICOM TCP/IP Network Communication Support as defined in Part 8 of the DICOM Standard. The product target Operating System is Windows XP.

#### **16.1.1 TCP/IP Stack**

The AXIOM Artis VB22 DICOM application uses the TCP/IP stack from the target operating system upon which it executes. It uses the MergeCOM-3 subroutine library from Merge Technologies Inc. that is based on a Berkeley socket interface.

##### **16.1.1.1 API**

The AXIOM Artis VB22 DICOM application uses the MergeCOM library that is based on a TCP/IP socket interface.

##### **16.1.1.2 Physical Media Support**

The AXIOM Artis VB22 DICOM application is indifferent to the physical medium over which TCP/IP executes; it inherits this from the target operating system upon which it executes.

**17 Extensions / Specializations / Privatizations****17.1.1 Standard Extended / Specialized / Private SOPs**

Please refer to Annex A for further information on these topics. A detailed overview is given there.

**17.1.2 Private Transfer Syntaxes**

Not applicable

## 18 Configuration

### 18.1 AE Title/Presentation Address Mapping

To ensure unique identification within the network the hostname should be used as part of the AE Titles (see examples below, hostname = NAME1). The string can be up to 16 characters long and must not contain any extended characters, only 7-bit ASCII characters (excluding Control Characters) are allowed according to DICOM Standard.

**Note:** the current implementation of syngo does not support the full DICOM Standard. Spaces and special characters (like &<> ") in the AE title string are not supported.

#### 18.1.1 DICOM Verification

The Verification Service uses the AE configuration of the DICOM Service that is checked with the C-ECHO message. e.g. Verification will use the Storage AE, if initiated to check the configuration of a remote DICOM node.

#### 18.1.2 DICOM AE Titles

Within syngo there are local application entity titles for HIS/RIS, Study Transfer and Print. They can be configured via Service-UI in "Configuration / DICOM / General".

##### 18.1.2.1 DICOM Storage AE Title

The DICOM Storage application provides the application entity title which can be configured via Service UI in "Configuration/DICOM/General":

e.g. STU\_NAME1

The port number is set to the fixed value of

104

##### 18.1.2.2 DICOM Query/Retrieve AE Title

The DICOM Query/Retrieve application uses the same application entity title as the DICOM Storage AE.

##### 18.1.2.3 DICOM Print AE Title

The DICOM Print application provides the application entity title which can be configured via Service UI in "Configuration/DICOM/General":

e.g. PRI\_NAME1

The port number is set to the fixed value of

108

**18.1.2.4 DICOM Modality Worklist AE Title**

The DICOM Modality Worklist application provides the application entity title which can be configured via Service UI in "Configuration/DICOM/General", e.g. HRI\_NAME1.

**18.2 Configurable Parameters**

The Application Entity Titles, host names and port numbers for remote AE are configured using the AXIOM Artis VB22 Service/Installation Tool. For each AET the list of services supported can be configured.

**18.2.1 Storage, Storage Commitment and Query/Retrieve**

The AXIOM Artis VB22 Service/Installation Tool can be used to set the AETs, port-numbers, host-names, IP-addresses and capabilities for the remote nodes (SCPs). The service user can select transfer syntaxes, compression modes and query models for each SCP separately.

The sending of the private SOP Class (Exam Protocol) can be disabled.

For sending or exporting, it can be configured for each destination if resizing (512, 8 bit) and/or ready-processing (see further information below) shall be used. Resizing and ready-processing can be configured depending on image type.

**Additional configurable parameters for Storage Commitment are:**

- flag to indicate whether the association will be kept open to receive the response or to close the association and be prepared to receive the response on another association.
- time-out which defines how long the association of N-ACTION is kept to receive a N-EVENT-REPORT on the same association. The same value is used to wait for a N-EVENT-REPORT on an other association (default 1 h).

**Additional configurable parameters for ready-processed are:**

- three different packages are defined
  - Package 1: Modality LUT, DSA (subtracting) and pixel shift, edge enhance
  - Package 2: Windowing and invert
  - Package 3: Shutter, Zoom, Roam, Flip, Overlay Graphics/Text (additionally add shutter attributes to header)
- four different modules can be configured for customized ready-processing for each node (N means "ready-process disabled", Y means "ready-process enabled")
- SUB means subtracted display
- AB means anatomical background
- For this version only Module 2 and 4 can be configured.

Ready Processed	Gray Scale				Transformation	
	MOD LUT	SUB incl. AB incl. Pixel shift	EE	Window incl. Invert	Shutter	Zoom incl. Roam
disabled		N		N		N
Module 1		Y		N		N
Module 2		Y		Y		N
Module 3		Y		N		Y

Module 4	Y	Y	Y
----------	---	---	---

Table 62 Ready-processed configuration

### 18.2.2 Print

The AXIOM Artis VB22 Service/Installation Tool can be used to configure the SCP (DICOM-Printer).

These parameters are mandatory to set:

- AET,
- host-name,
- IP-address and
- Port-number.

These parameters have defaults as per configuration file and can be changed:

- default camera (yes/no),
- pixel size,
- additional or changed film sheet formats (e.g. inch 14x14, inch 14x17, ...),
- list with mapping pixel size to each film sheet format,
- minimal density,
- stored printed film jobs,
- media type,
- film destination.

### 18.2.3 Modality Worklist

The Service application can be used to set the AET, port number, host name, IP address, capabilities and time-outs for the remote node (SCP)

**Additional configurable parameters for Modality Worklist Query are:**

- Query Waiting time - the time to wait for the C-FIND-RSP after sending the C-FIND-RQ (default 20 sec.)
- Max Query Match Number - the maximum number of entries accepted in one worklist (default is 200)
- Query Interval: the time between two C-FIND-RQ to the Hospital Information system (default is 60 min., minimum is 3 min., maximum is 1440 min. i.e. 24 hours)
- Broad Worklist Query behavior (two values are defined):
  - Set the AE Title search attribute to the own AE Title, and the Modality search attribute to <zero length>.
  - Set the Modality search attribute to the own modality and the AE Title search attribute to <zero length>.

### 18.3 Default Parameters

This installation tool also uses some default parameters:

- max PDU size set to 262144 Bytes (256 KB)
- time-out for accepting/rejecting an association request: 60 s
- time-out for responding to an association open/close request: 60 s
- time-out for accepting a message over network: 60 s
- time-out for waiting for data between TCP/IP-packets: 60 s

The time-outs for waiting for a Service Request/Response message from the remote node are as follows:

- for Storage SCP/SCU: 600 s
- for Storage Commitment SCU:  
time-out for Response to N-ACTION: 600 s
- for Query/Retrieve SCP/SCU: 600 s

for Print Management SCU:

- time-out for Response to N-SET-RQ: 240 s
- time-out for Response to other Requests: 60 s

## 19 Support of Extended Character Sets

The AXIOM Artis VB22 DICOM application supports the ISO 8859 Latin 1 (ISO-IR 100) character set.

Also the Japanese language character sets JIS X 0201 (ISO-IR 13 Japanese katakana and ISO-IR 14 Japanese romaji), JIS X 0208 (ISO-IR 87 Japanese kanji) and JIS X 0212 (ISO-IR 159 Supplementary Japanese kanji) are supported.

When there is a mismatch between the "Specific Character Set" attribute (0008,0005) and the characters encoded in an IOD received by the system, then the following measures are taken to make the characters DICOM conform:

- Try to import with ISO\_IR 100. If ISO\_IR 100 fails, convert each illegal character to a '?'.

## 20 AXIOM Artis VB22 Offline Media Application Profile

Contains a AXIOM Artis VB22 specific Application Profile since DICOM does not provide a "General Angio/X-Ray Application Profile" for Storage on "Offline Media".

Structure of this Application Profile is defined in Part 11 of the [DICOM] Standard.

It is needed to describe the requirements for Offline Media Storage of the private IOD (Non-Image IOD).

The profile is shared with LEONARDO Workstation and therefore support of MOD Media is included, even if not used with AXIOM Artis based systems.

### 20.1 Class and Profile Identification

This document defines an Application Profile Class for X-Ray Modular Angiographic / Radiographic modalities or applications.

The identifier for this class shall be PRI-XAMAS. This class is intended to be used for interchange of extended and private Information Objects via CD-R or re-writeable magneto-optical disk (MOD) offline media between dedicated Angiography, Neuro-Radiology, Radiography applications build from a common architecture.

The specific application profiles in this class are shown in Table 1:

Application Profile	Identifier	Description
Universal X-Ray Modular Angio/ Radio System on CD-R	PRI-XAMAS-CD	Handles interchange of Composite SOP Instances and privately defined SOP Instances (Dose Reports, Object Graphics, Quantification Results and more).

Table 63 PRI-XAMAS Universal Angio/Radio Class Profile

Equipment claiming conformance for this X-Ray Modular Angiographic/Radiographic Application Profile Class shall make a clear statement on handling of the private defined SOP Instances.

### 20.2 Clinical Context

This application profile facilitates the interchange of original acquired and derived images and private data related to them. Typical media interchange would be from in-lab acquisition equipment to dedicated angio workstations and archive systems with specific extensions to handle the private data objects (in both directions).

Additionally, images (from MR, CT, US) used to prepare interventional procedures, multi-modality images (e.g. integrated US) and images derived from primary diagnostic images, such as annotations, quantitative analysis images, reference images may be interchanged via this profile.

#### 20.2.1 Roles and Service Class Options

This Application Profile uses the Media Storage Service Class defined in PS 3.4 with the Interchange Option.

The Application Entity shall support one or more of the roles of File Set Creator (FSC), File Set Reader (FSR), and File Set Updater (FSU), defined in PS 3.10.

### 20.2.1.1 File Set Creator

The Application Entity acting as a File-Set Creator generates a File Set under the PRI-XAMAS Application Profiles.

File Set Creators shall be able to generate the Basic Directory SOP Class in the DICOMDIR file with all the subsidiary Directory Records related to the Image SOP Classes and Private SOP Classes stored in the File Set.

In case of the PRI-XAMAS-CD profile, the FSC shall offer the ability to either finalize the disc at the completion of the most recent write session (no additional information can be subsequently added to the disc) or to allow multi-session (additional information may be subsequently added to the disc).

#### Note

A multiple volume (a logical volume that can cross multiple physical media) is not supported by this Application Profile Class. If a set of Files, e.g., a Study, cannot be written entirely on one CD-R, the FSC will create multiple independent DICOM File-Set such that each File-Set can reside on a single CD-R medium controlled by its individual DICOMDIR file. The user of the FSC can opt to use written labels on the discs to reflect that there is more than one disc for this set of files (e.g., a Study).

### 20.2.1.2 File Set Reader

The role of the File Set Reader shall be used by Application Entities which receive the transferred File Set.

File Set Readers shall be able to read all the defined SOP Instances files defined for the specific Application Profiles to which a conformance claim is made, using all the defined Transfer Syntaxes.

### 20.2.1.3 File Set Updater

The role of the File Set Updater shall be used by Application Entities, which receive a transferred File Set and update it by the addition of processed information.

File Set Updaters shall be able to read and update the DICOMDIR file. File-Set Updaters do not have to read the image/private information objects. File-Set Updaters shall be able to generate any of the SOP Instances files defined for the specific Application Profiles to which a conformance claim is made, and to read and update the DICOMDIR file.

In case of the PRI-XAMAS-CD profile, the FSU shall offer the ability to either finalize a disc at the completion of the most recent write session (no additional information can be subsequently added to the disc) or to allow multi-session (additional information may be subsequently added to the disc).

#### Note (for CD-R)

If the disc has not been finalized, the File-Set Updater will be able to update information assuming there is enough space on the disc to write a new DICOMDIR file, the information, and the fundamental CD-R control structures. CD-R control structures are the structures that inherent to the CD-R standards; see PS 3.12

**20.3 PRI-XAMAS Profiles**

**20.3.1 SOP Classes and Transfer Syntaxes**

These Application Profiles are based on the Media Storage Service Class with the Interchange Option.

Information Object Definition	SOP Class UID	Transfer Syntax UID	FSC	FSR	FSU
Basic Directory	1.2.840.10008.1.3.10	ELE	M	M	M
X-Ray Angiographic Image	1.2.840.10008.5.1.4.1.1.12.1	JPEG LL P14	M	M	O
		ELE	O	M	O
		EBE	O	M	O
		JPEG Lossy	O	O	O
X-Ray Radiofluoroscopic Image	1.2.840.10008.5.1.4.1.1.12.2	JPEG LL P14	M	M	O
		ELE	O	M	O
		EBE	O	M	O
		JPEG Lossy	O	O	O
Secondary Capture Image	1.2.840.10008.5.1.4.1.1.7	ELE	M	M	O
		JPEG LL P14	O	M	O
		EBE	O	M	O
		JPEG Lossy	O	O	O
CR Image	1.2.840.10008.5.1.4.1.1.1	ELE	M	M	O
		JPEG LL P14	O	M	O
		EBE	O	M	O
		JPEG Lossy	O	O	O
DX Image – For Processing	1.2.840.10008.5.1.4.1.1.1.1.1	ELE	M	M	O
		JPEG LL P14	O	M	O
		EBE	O	M	O
		JPEG Lossy	O	O	O
DX Image – For Presentation	1.2.840.10008.5.1.4.1.1.1.1	ELE	M	M	O
		JPEG LL P14	O	M	O
		EBE	O	M	O
		JPEG Lossy	O	O	O
CT image	1.2.840.10008.5.1.4.1.1.2	ELE	M	M	O
		JPEG LL P14	O	M	O
		EBE	O	M	O
		JPEG Lossy	O	O	O
MR Image	1.2.840.10008.5.1.4.1.1.4	ELE	M	M	O
		JPEG LL P14	O	M	O
		EBE	O	M	O
		JPEG Lossy	O	O	O
Ultrasound Image	1.2.840.10008.5.1.4.1.1.6.1	ELE	M	M	O
		JPEG LL P14	O	M	O
		EBE	O	M	O
		JPEG Lossy	O	O	O
		RLE	O	M	O
Ultrasound Multi-frame Image	1.2.840.10008.5.1.4.1.1.3.1	ELE	M	M	O
		JPEG LL P14	O	M	O
		EBE	O	M	O
		JPEG Lossy	O	O	O
		RLE	O	M	O
NM Image	1.2.840.10008.5.1.4.1.1.20	ELE	M	M	O
		JPEG LL P14	O	M	O
		EBE	O	M	O

Information Object Definition	SOP Class UID	Transfer Syntax UID	FSC	FSR	FSU
		<b>JPEG Lossy</b>	O	O	O
CSA Non-Image	1.3.12.2.1107.5.9.1	<b>ELE</b>	O	M	O
Detached Patient Management	1.2.840.10008.3.1.2.1.1	<b>ELE</b>	O	see DCS	O

Table 64 PRI-XAMAS SOP Classes and Transfer Syntaxes

Abbreviation	Transfer Syntax UID	Transfer Syntax
<b>ELE</b>	1.2.840.10008.1.2.1	Explicit VR Little Endian Uncompressed
<b>EBE</b>	1.2.840.10008.1.2.2	Explicit VR Big Endian Uncompressed
<b>JPEG LL P14</b>	1.2.840.10008.1.2.4.70	JPEG Lossless Process 14 (selection value 1)
<b>JPEG Lossy</b>	1.2.840.10008.1.2.4.50 1.2.840.10008.1.2.4.51	JPEG Lossy (baseline or extended)
<b>RLE</b>	1.2.840.10008.1.2.5	RLE Lossless

Table 65 Abbreviations for Transfer Syntaxes

FSC, FSR, FSU – denote the requirements for those roles  
 O – Optional  
 M - Mandatory

### 20.3.2 Physical Media and Formats

The PRI-XAMAS-CD Profile requires the 120mm CD-R physical media with the ISO/IEC 9660 Media Format, as defined in PS3.12.

The PRI-XAMAS-MOD23 Profile requires the 130mm 2.3 GB R/W MOD physical medium with the PCDOS Media Format, as defined in PS3.12.

The PRI-XAMAS-MOD41 Profile requires the 130mm 4.1 GB R/W MOD physical medium with the PCDOS Media Format, as approved by DICOM Supplement 62.

### 20.3.3 Directory Information in DICOMDIR

Conforming Application Entities shall include in the DICOMDIR File the Basic Directory IOD containing Directory Records at the Patient and subsidiary levels appropriate to the SOP Classes in the File-set. All DICOM files in the File-set incorporating SOP Instances defined for the specific Application profile, shall be referenced by Directory Records.

**Note**

DICOMDIRs with no directory information are not allowed by this Application Profile. Privately defined IODs will be referenced by "PRIVATE" Directory Records.

#### 20.3.3.1 Basic Directory IOD Specialization Option

This Application Profile makes use of optional attributes of the Basic Directory IOD to support recognition of Patient’s Storage Service request results in spanning multiple volumes (file sets). Therefore, the File Set Descriptor File can be used and is then referenced by optional Basic Directory IOD attributes. If existent, the specified Descriptor File may be used by FSR applications. Any FSU, FSC shall make a clear Statement if the Descriptor File mechanism is used according to the specialization defined in this Application Profile.

The Descriptor Files shall have the following contents:

One single Line without any control-characters and according to the Basic Character-Set having the following defined text:

"MULTIVOLUME: xx of yy"

xx, yy are replaced by the actual Number of the volume (xx) and the Total Number of Volumes in the set (yy).

If used, the Descriptor File shall have the File ID "README" and reside in same directory level as the DICOMDIR. It is referenced by the attribute [0004,1141] File-set Descriptor File ID having the defined content of "README".

**20.3.3.2 Additional Keys**

File-set Creators and Updaters are required to generate the mandatory elements specified in PS 3.3, Annex F of the DICOM Standard. Table "Table 66 PRI-XAMAS Additional DICOMDIR Keys

" specifies the additional associated keys. At each directory record level other additional data elements can be added, but it is not required that File Set Readers be able to use them as keys. Refer to the Basic Directory IOD in PS 3.3.

Key Attribute	Tag	Directory Record Level	Type	Notes
Date of Birth	(0010,0030)	PATIENT	2C	required, if present in SOP Instance
Patient's Sex	(0010,0040)	PATIENT	2C	required, if present in SOP Instance
Series Date	(0008,0021)	SERIES	3	
Series Time	(0008,0031)	SERIES	3	
Institute Name	(0008,0080)	SERIES	2C	required, if present in SOP Instance
Institution Address	(0008,0081)	SERIES	2C	required, if present in SOP Instance
Series Description	(0008,103E)	SERIES	3	
Performing Physician's Name	(0008,1050)	SERIES	2C	required, if present in SOP Instance
Image Type	(0008,0008)	IMAGE	1C	required, if present in SOP Instance
SOP Class UID	(0008,0016)	IMAGE	3	
SOP Instance UID	(0008,0018)	IMAGE	3	
Image Date	(0008,0023)	IMAGE	3	
Image Time	(0008,0033)	IMAGE	3	
Referenced Image Sequence	(0008,1140)	IMAGE	1C	required, if present in SOP Instance
> Referenced SOP Class UID	(0008,1150)			
> Referenced SOP Instance UID	(0008,1155)			
Image Position (Patient)	(0020,0032)	IMAGE	2C	required, if present in SOP Instance
Image Orientation (Patient)	(0020,0037)	IMAGE	2C	required, if present in SOP Instance
Frame of Reference UID	(0020,0052)	IMAGE	2C	required, if present in SOP Instance
Rows	(0028,0010)	IMAGE	3	
Columns	(0028,0011)	IMAGE	3	
Pixel Spacing	(0028,0030)	IMAGE	1C	required, if present in SOP Instance
Calibration Image	(0050,0004)	IMAGE	2C	required, if present in SOP Instance
Icon Image Sequence	(0088,0200)	IMAGE	3	Required for Image SOP Classes
> Samples per Pixel	(0028,0002)			1
> Photometric Interpretation	(0028,0004)			MONOCHROME2
> Rows	(0028,0010)			128 for XA, 64 for others
> Columns	(0028,0011)			128 for XA, 64 for others
> Bits Allocated	(0028,0100)			8
> Bits Stored	(0028,0101)			8
> High Bit	(0028,0102)			7
> Pixel Representation	(0028,0103)			0
> Pixel Data	(7FE0,0010)			Icon Image

Table 66 PRI-XAMAS Additional DICOMDIR Keys

### 20.3.3.3 Private Directory Record Keys

Private Directory Records are supported by this Application Profile Class at the following Level - IMAGE. The PRIVATE Directory Records will have required elements in addition to the mandatory elements specified in PS 3.3.

The following table will list the additional required keys for PRIVATE Directory Records:

Key Attribute	Tag	Directory Record Level	Type	Notes
Private Record UID	(0004,1432)	PRIVATE	1	See Conformance Statement
SOP Class UID	(0008,0016)	PRIVATE	1C	required, if present in SOP Instance
SOP Instance UID	(0008,0018)	PRIVATE	1C	required, if present in SOP Instance
Image Type	(0008,0008)	PRIVATE	3	
Acquisition Date	(0008,0022)	PRIVATE	3	
Acquisition Time	(0008,0032)	PRIVATE	3	
Acquisition Number	(0020,0012)	PRIVATE	3	
CSA Data Type	(0029,xx08)	PRIVATE	1	private owner code = SIEMENS CSA NON-IMAGE
CSA Data Version	(0029,xx09)	PRIVATE	3	private owner code = SIEMENS CSA NON-IMAGE

Table 67 PRI-XAMAS Additional PRIVATE Record Keys

### 20.3.3.4 Icon Images

Directory Records of type SERIES or IMAGE may include Icon Images. The Icon Image pixel data shall be as specified in PS 3.3 "Icon Image Key Definition", and restricted such, that Bits Allocated (0028,0100) and Bits Stored (0028,0101) shall be equal 8, and Rows (0028,0010) and Columns (0028,0011) shall be equal to 128 for XA Images and 64 for all other Images. The Photometric Interpretation (0028,0004) shall always be restricted to "MONOCHROME2".

PRIVATE Directory Records will not contain Icon Image information.

## 20.3.4 Other Parameters

This section defines other parameters common to all specific Application Profiles in the PRI-XAMAS class which need to be specified in order to ensure interoperable media interchange.

### 20.3.4.1 Multi-Frame JPEG Format

The JPEG encoding of pixel data shall use Interchange Format (with table specification) for all frames.

### 20.3.4.2 Attribute Value Precedence

The values of attributes contained in a Detached Patient Management SOP Instance referenced by a DicomDIR PATIENT Directory Record shall take precedence over the values of those attributes contained in the SOP Instance referenced by a subsidiary Directory Record. The DicomDIR Directory Records shall have key attribute values in accordance with this precedence.

#### Note

This allows patient identification and demographic information to be updated without changing the composite Image IOD files. The DicomDIR file thus is critical in establishing the link between the updated information and the image. As an example, at the time an Image file was written, the patient's name therein was incorrect, or inconsistent with the Hospital Information System records. Subsequently, a Detached Patient Management file with the corrected name is added to the file-set. The FSR should use the name from the Patient File rather than in the Image File.

## 21 Application Profile Conformance Statement

This chapter defines the Conformance Statement to all “Offline Media Application Profiles (incl. private extensions)” supported by the AXIOM Artis VB22 archive options.

Those application profiles supported shall be:

- 1024 Extended Cardiac Application Profile
- General Purpose CDR Profiles
- AXIOM Artis VB22 private Application Profile

### 21.1 Introduction

#### 21.1.1 Purpose

This DICOM Conformance Statement is written according to part PS 3.2 of [DICOM] .

The applications described in this conformance statement are the SIEMENS AXIOM Artis VB22 based on *syngo*® software<sup>a</sup>. The AXIOM Artis VB22 DICOM offline media storage service implementation acts as FSC, FSU and/or FSR for the specified application profiles and the related SOP Class instances.

#### 21.1.2 Scope

This DICOM Conformance Statement refers to SIEMENS AXIOM Artis VB22 based products using AXIOM Artis VB22 software. The following table relates AXIOM Artis VB22 software names to SIEMENS products:

Software Name	SIEMENS <i>syngo</i> -based Product
VB22	AXIOM Artis VB22

Table 68 Siemens AXIOM Artis VB22 based products

#### 21.1.3 Definitions, Abbreviations

##### 21.1.3.1 Definitions

DICOM Digital Imaging and Communications in Medicine  
 DIMSE DICOM Message Service Element  
 DIMSE-C DICOM Message Service Element with Composite information objects

##### 21.1.4 Abbreviations

ACR American College of Radiology  
 AE DICOM Application Entity  
 ASCII American Standard Code for Information Interchange  
 CD, CD-R Compact Disk Recordable  
 DB Database  
 DCS DICOM Conformance Statement  
 FSC File Set Creator  
 FSR File Set Reader  
 FSU File Set Updater

<sup>a</sup> *syngo* is a registered trademark of Siemens AG.

IOD	DICOM Information Object Definition
ISO	International Standard Organization
MAS or M.A.S.	AX-Workstation (for Angiographic/Radiographic viewing)
NEMA	National Electrical Manufacturers Association
O	Optional Key Attribute
PDU	DICOM Protocol Data Unit
R	Required Key Attribute
RWA	Real-World Activity
U	Unique Key Attribute

### 21.1.5 References

[DICOM] Digital Imaging and Communications in Medicine (DICOM), NEMA PS 3.1-16

### 21.1.6 Remarks

DICOM and this Conformance Statement, by itself, does not guarantee interoperability. However, the Conformance Statement facilitates a first-level validation for interoperability between different applications supporting the same DICOM functionality as SCU and SCP, respectively.

This Conformance Statement is not intended to replace validation with other DICOM equipment to ensure proper exchange of information intended.

The scope of this Conformance Statement is to facilitate communication with Siemens and other vendors' Medical equipment. The Conformance Statement should be read and understood in conjunction with the DICOM Standard [DICOM] . However, by itself it is not guaranteed to ensure the desired interoperability and a successful interconnectivity.

The user should be aware of the following important issues:

- **Interoperability**  
Interoperability refers to the ability of application functions, distributed over two or more systems, to work successfully together. The integration of medical devices into a networked environment may require application functions that are not specified within the scope of DICOM. Consequently, using only the information provided by this Conformance Statement does not guarantee interoperability of SIEMENS equipment with non-SIEMENS equipment. It is the user's responsibility to analyze thoroughly the application requirements and to specify a solution that integrates SIEMENS equipment with non-SIEMENS equipment.
- **Validation**  
SIEMENS equipment has been carefully tested to assure that the actual implementation of the DICOM interface corresponds with this Conformance Statement. Where SIEMENS equipment is linked to non-SIEMENS equipment, the first step is to compare the relevant Conformance Statements. If the Conformance Statements indicate that successful information exchange should be possible, additional validation test will be necessary to ensure the functionality, performance, accuracy and stability of image and image related data. It is the responsibility of the user (or user's agent) to specify the appropriate test suite and to carry out the additional validation tests.
- **New versions of the DICOM Standard**  
The DICOM Standard will evolve in future to meet the user's growing requirements and to incorporate new features and technologies. SIEMENS is actively involved in this evolution and plans to adapt its equipment to future versions of the DICOM Standard. In order to do so, SIEMENS reserves the right to make changes to its products or to discontinue its delivery. The user should ensure that any non-SIEMENS provider linking to SIEMENS equipment, also adapts to future versions of the DICOM Standard. If not, the incorporation of DICOM enhancements into SIEMENS equipment may lead to loss of connectivity (in case of networking) and incompatibility (in case of media).

## 21.2 Implementation Model

### 21.2.1 Application Data Flow Diagram

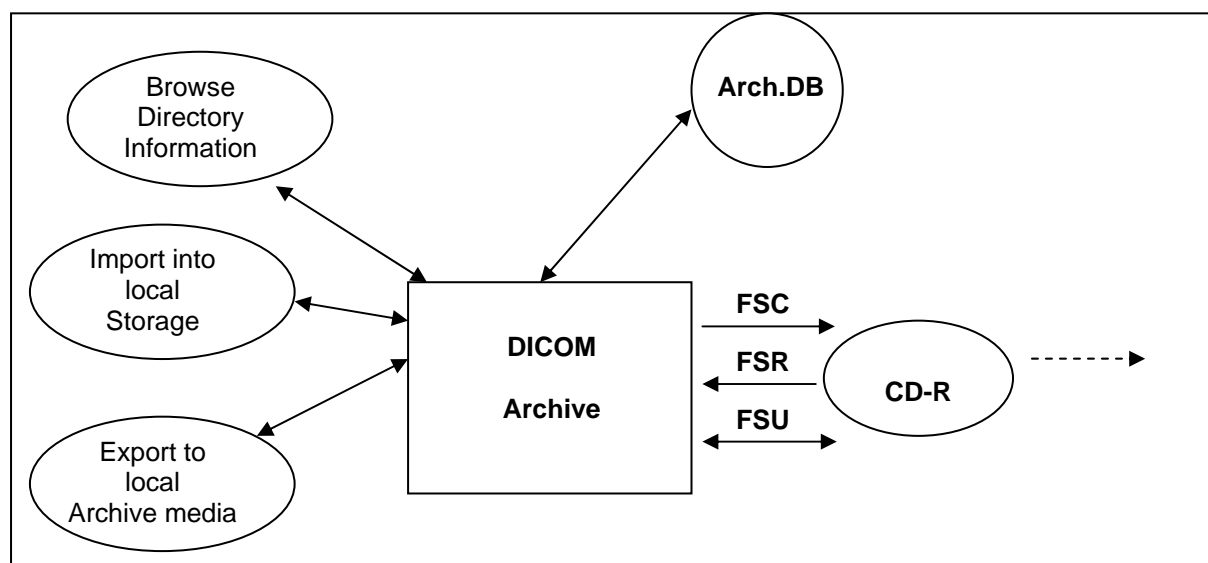

**Figure 9 Application Data Flow Diagram**

The DICOM archive application will serve as an interface to the CD-R offline medium device. It serves interfaces to include the offline media directory into the browser and to copy SOP instances to a medium or retrieve SOP Instances from medium into local storage.

The DICOM Archive application will support the 120mm CD-R medium.

The FSU role will update new SOP Instances only to media with pre-existing File-sets conforming to the Application Profiles supported.

The contents of the DICOMDIR will be temporarily stored in Archive-Database.

### 21.2.2 Functional Definitions of AEs

The AXIOM Artis VB22 DICOM offline media storage application consists of the DICOM Archive application entity serving all interfaces to access offline media. The DICOM Archive application is capable of

1. creating a new File-set onto an unwritten medium (Export to...).
2. updating an existing File-set by writing new SOP Instances onto the medium (Export to...).
3. importing SOP Instances from the medium onto local storage
4. reading the File-sets DICOMDIR information into temporary database and pass it to display applications.

### 21.2.3 Sequencing of Real-World Activities

The DICOM Archive application will not perform updates before the Directory information of the DICOMDIR is completely read.

When performing updates, the SOP instances are checked for existence before updating. Duplicate instances will be avoided.

**21.2.4 File Meta Information Options**

Implementation Class UID	1.3.12.2.1107.5.5.9.20000101
Implementation Version Name	“SIEMENS_SWFVX47A”

Table 69 File Meta Information Options

**21.3 AE Specifications**

**21.3.1 DICOM Archive Specification**

The DICOM Archive provides Standard conformance to Media Storage Service Class (Interchange Option). In addition Augmented conformance is provided to store extra data attributes important for the full feature support of the AXIOM Artis VB22 product SW. Details are listed in following Table:

Application Profiles Supported	Real-World Activity	Role	SC Option
PRI-XAMAS-CD AUG-XA1K-CD *1	Browse Directory Information	FSR	Interchange
	Import into local Storage	FSR	Interchange
	Export to local Archive Media	FSC, FSU	Interchange
STD-GEN-CD STD-XABC-CD STD-XA1K-CD	Browse Directory Information	FSR	Interchange
	Import into local Storage	FSR	Interchange

\*1 – With no Private SOP Class used, the PRI-SYNGO-CD profile definitions are appropriate to describe the augmentation of the related -STD Profiles.

Table 70 Application profiles, Activities, and Roles for DICOM Archive

On AXIOM Artis based Cardiac Systems the Private Extended MAS Profile (PRI-XAMAS-CD) will be preferably used by the system. The General Purpose Interchange Profile (STDGEN-CD), Basic Cardiac Profile (STD-XABC-CD) and 1024 X-Ray Angiographic Profile (STD-XA1K-CD) will be supported with read capability of the related media.

**21.3.1.1 File Meta Information for the Application Entity**

The Source Application Entity Title is set by configuration. See Chapter “Configuration” for details.

**21.3.1.2 Real-World Activities for this Application Entity**

**21.3.1.2.1 Real-World Activity: Browse Directory Information**

The DICOM Archive application acts as FSR using the interchange option when requested to read the media directory.

The DICOM archive application will read the DICOMDIR and insert those directory entries, that are valid for the application profiles supported, into a local database. The database can then be used for browsing media contents.

**Note**

IconImageSQ is also supported in DICOMDIR. But only those Icon Images with BitsAllocated (0028,0100) equal to 8 and size of 64x64 or 128x128 pixels are imported into database and are visible in the Browser.

**21.3.1.2.1.1 Application Profiles for the RWA: Browse Directory Information**

See Table in Chapter 21.3.1 for the Application Profiles listed that invoke this Application Entity for the Browse Directory Information RWA.

**21.3.1.2.2 Real-World Activity: Import into local Storage**

The DICOM Archive application acts as FSR using the interchange option when requested to read SOP Instances from the medium into the local storage.

The SOP Instance selected from the media directory will be copied into the local storage. Only SOP Instances, that are valid for the application profile supported and are listed as supported by the Storage SCP Conformance section (see chapter 5.1.3.1.2), can be retrieved from media storage. This is due to the fact that the Browse Directory Information will filter all SOP Instances not matching the Application profiles supported.

***During operation no “Attribute Value Precedence” is applied to the SOP Instances. Detached Patient Management is not supported.***

For media conforming to the STD-GEN-CD Profile the following SOP classes will be supported as an FSR:

Information Object Definition	SOP Class UID	Transfer Syntax UID
X-Ray Angiographic Image	1.2.840.10008.5.1.4.1.1.12.1	Explicit VR Little Endian Uncompressed 1.2.840.10008.1.2.1
CT image	1.2.840.10008.5.1.4.1.1.2	Explicit VR Little Endian Uncompressed 1.2.840.10008.1.2.1
MR Image	1.2.840.10008.5.1.4.1.1.4	Explicit VR Little Endian Uncompressed 1.2.840.10008.1.2.1
CSA Non-Image	1.3.12.2.1107.5.9.1	Explicit VR Little Endian Uncompressed 1.2.840.10008.1.2.1

Table 71 STD-GEN-CD Supported SOP Classes for FSR Role

**21.3.1.2.2.1 Application Profiles for the RWA: Import into local Storage**

See Table in section 21.3.1 for the Application Profiles listed that invoke this Application Entity for the Import into Local Storage RWA.

**21.3.1.2.3 Real-World Activity: Export to local Archive Media**

The DICOM Archive application acts as FSU (for media with existing DICOM file-set) or FSC (media not initialized) using the interchange option when requested to copy SOP Instances from the local storage to local Archive Medium.

The DICOM Archive application will receive a list of SOP Instances to be copied to the local archive medium. According to the state of the medium inserted (new medium, Medium with DICOM file-set) the validity of the SOP Instances according to the applicable profile is checked. Only valid SOP Instances are accepted.

When the DICOM archive application is requested to copy SOP Instances the preferred application profile according configuration (AUG-XA1K-CD or PRI-XAMAS-CD) will be used to validate and copy the referred SOP Instances. When creating a new file-set no Descriptor File will be allocated and the related ID is not used.

The DICOM archive application will not close the medium.

With the “Export” function and a copy of images in Cardiac Format (512x512, 8Bit) can be written onto medium (configurable). Please refer to the Storage section (5.1.2.1.6) RWA description to learn more about the type of conversion that is performed on the Instances.

**21.3.1.2.3.1 Application Profiles for the RWA: Export to local Archive Media**

See Table in section 21.3.1 for the Application Profiles listed that invoke this Application Entity for the Export to local Archive Media RWA.

**21.4 Augmented and Private Profiles**

**21.4.1 Augmented Application Profiles**

With no private Siemens Non-Images stored onto Medium, the definitions of the PRI-XAMAS-CD Profile are applicable to denote the augmentations for the STD-XA1K-CD Standard Profile.

Storage of Private Information Objects will only be supported with reference to a Private Application Profile (see next section).

**21.4.2 Private Application Profiles**

**21.4.2.1 PRI-XAMAS-CD**

The DICOM Archive application is conforming to the PRI-XAMAS-CD application profile provided in a separate document. Please refer to next section for detailed definition of SOP classes supported in accordance to this Application Profile.

**21.5 Extensions, Specialization and Privatization of SOP Classes and Transfer Syntaxes**

The SOP Classes listed refer in majority to those created by the equipment to which this conformance Statement is related to. For SOP classes not listed in this section, please refer to the Storage section of the DICOM Conformance Statement of the product. This will include all SOP Instances that can be received and displayed and therefore will be included into offline media storage even though these SOP Instances are not created by the equipment serving the Media Storage Service.

**21.5.1 SOP Specific Conformance Statement for Basic Directory**

The Basic Directory Header will not contain Information to indicate the current medium is part of a sequence of multiple media holding the Objects of one patient/study in total.

**21.5.1.1 Extension, Specialization for SIEMENS Non-Image Objects**

According to the PRI-XAMAS Application Profile Class the usage of the Private Creator UIDs and further optional keys for the Directory Records referring to SIEMENS Non-Image Objects are listed in the following tables.

Attribute	Tag	Value used
Private Record UID	(0004,1432)	1.3.12.2.1107.5.9.1
SOP Class UID	(0008,0016)	1.3.12.2.1107.5.9.1

Table 72 Extension, Specialization for SIEMENS Non-Image Objects

For those "Non-Images" no Icon Image Sequence will be generated.

**21.6 Configuration****21.6.1 AE Title Mapping****21.6.1.1 DICOM Media Storage AE Title**

The DICOM Storage application provides the application entity title:

CsalmageManager

**21.7 Support of Extended Character Sets**

The Siemens AXIOM Artis VB22 DICOM archive application supports the ISO 8859 Latin 1 (ISO-IR 100) character set.

Also the Japanese language character sets JIS X 0201 (ISO-IR 13 Japanese katakana and ISO-IR 14 Japanese romaji), JIS X 0208 (ISO-IR 87 Japanese kanji) and JIS X 0212 (IOS-IR 159 Supplementary Japanese kanji) are supported.

When there is a mismatch between the SCS tags (0008,0005) and the characters in an IOD received by the system, then the following measures are taken to make the characters DICOM conform:

- Try to import with ISO\_IR 100. If ISO\_IR 100 fails, convert each illegal character to a '?'.



**Annex A: Additional Information**

**A.1 SIEMENS Private Non-Image IOD**

For encoding binary data-streams not representing image data, Siemens has created a private “Non-Image IOD” according to the rules governed by the DICOM Standard. The following section will define this Private IOD. It can be communicated with Network Storage Service and Offline Media Storage Services.

The Siemens “Non-Image IOD” is identified by a private Non-Image Storage SOP Class UID.

Private Non-Image Object	Private Non-Image IOD
CSA Non-Image	1.3.12.2.1107.5.9.1

Table 73 SIEMENS Private Non-Image IOD

**A.1.1 Siemens Non-Image IOD – E-R Model**

The E-R model in A.1.2 depicts those components of the DICOM Information Model which directly refer to the Siemens Non-Image IOD. The Frame of Reference IE, Overlay IE, Modality Lookup-Table IE, VOI Lookup-Table IE and Curve IE are not components of the Siemens Non-Image IOD.

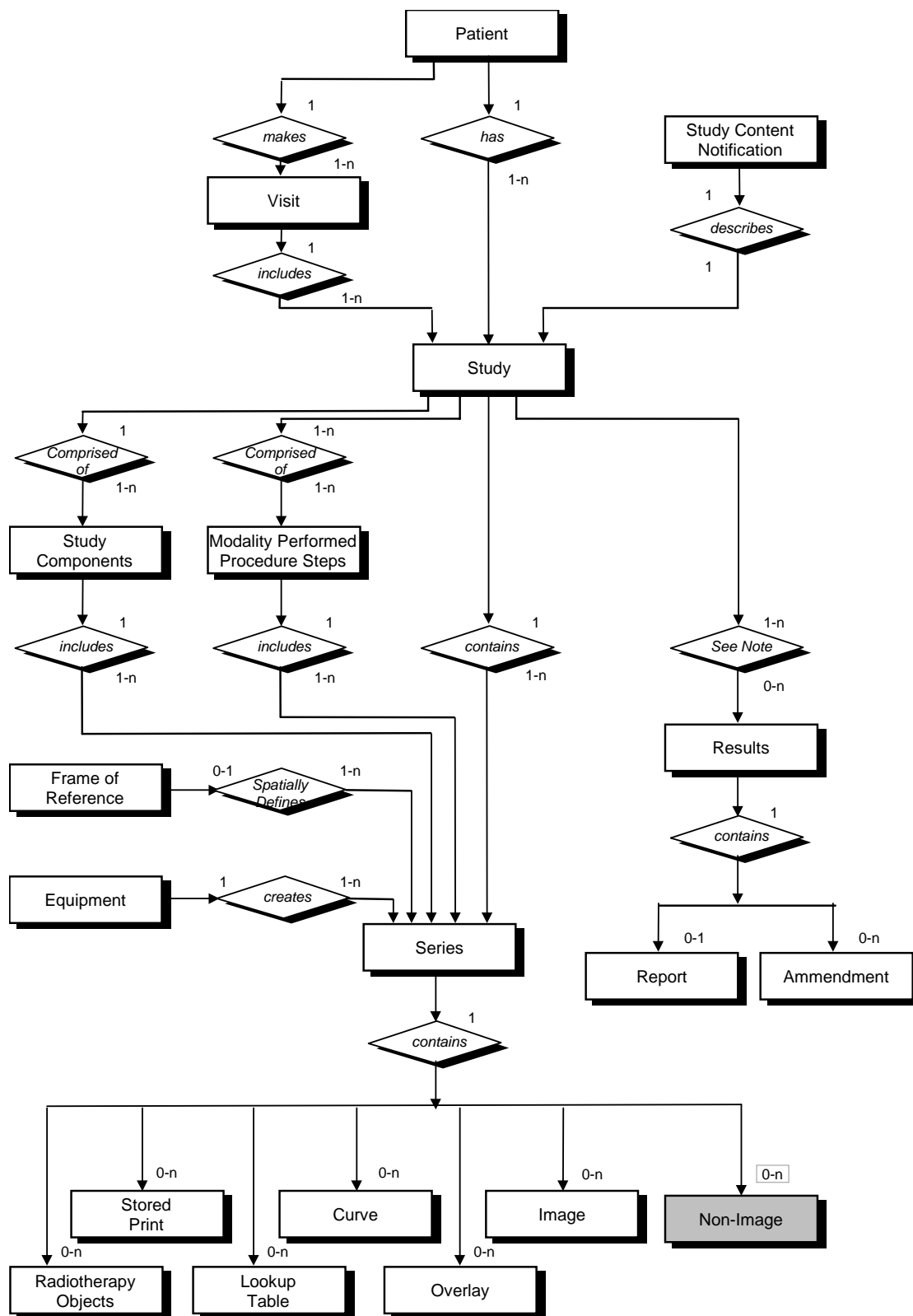

Figure 10 DICOM Information Model

**A.1.2 Siemens Non-Image IOD - Module Table**

IE	Module	Reference	Usage
Patient	Patient	[1] PS3.3 C.7.1.1	M
Study	General Study	[1] PS3.3 C.7.2.1	M
	Patient Study	[1] PS3.3 C.7.2.2	U
Series	General Series	[1] PS3.3 C.7.3.1	M
Equipment	General Equipment	[1] PS3.3 C.7.5.1	U
CSA	CSA Image Header	A.2.1	U
	CSA Series Header	A.2.2	U
	MEDCOM Header	A.2.3	U
	CSA Non-Image	A.1.3.1	M
	SOP Common	[1] PS3.3 C.12.1	M

Table 74 CSA Non-Image IOD Modules

**A.1.3 Siemens Non-Image IOD - Modules**

**A.1.3.1 CSA Non-Image Attributes**

The table in this section contains private IOD Attributes that describe CSA Non-Images.

Attribute Name	Tag	Owner	Type	Notes
Image Type	(0008,0008)	-	3	Image identification characteristics.
Acquisition Date	(0008,0022)	-	3	The date the acquisition of data that resulted in this data set started.
Acquisition Time	(0008,0032)	-	3	The time the acquisition of data that resulted in this data set started.
Conversion Type	(0008,0064)	-	3	Describes the kind of image conversion. Defined Terms: DV = Digitized Video, DI = Digital Interface, DF = Digitized Film, WSD = Workstation.
Referenced Image Sequence	(0008,1140)	-	3	A sequence which provides reference to a set of Image SOP Class/Instance identifying other images significantly related to this data set. Encoded as sequence of items: (0008,1150) and (0008,1155).
Derivation Description	(0008,2111)	-	3	A text description of how this data set was derived.
Source Image Sequence	(0008,2112)	-	3	A Sequence which identifies the set of Image SOP Class/Instance pairs of the Images which were used to derive this data set. Zero or more Items may be included in this Sequence. Encoded as sequence of items: (0008,1150) and (0008,1155).
Patient Position	(0018,5100)	-	3	Patient position descriptor relative to the equipment.
Acquisition Number	(0020,0012)	-	3	A number identifying the single continuous gathering of data over a period of time which resulted in this data set.
Instance Number	(0020,0013)	-	3	A number that identifies this data set.
Frame of Reference UID	(0020,0052)	-	3	Uniquely identifies the frame of reference for a Series.
Image Comments	(0020,4000)	-	3	User-defined comments about the image.
Quality Control Image	(0028,0300)	-	3	Indicates whether or not this image is a quality control or phantom image. If this Attribute is absent, then the image may or may not be a quality control or phantom image. Enumerated Values: YES, NO.

Attribute Name	Tag	Owner	Type	Notes
Burned in Annotation	(0028,0301)	-	3	Indicates whether or not image contains sufficient burned in annotation to identify the patient and date the image was acquired. If this Attribute is absent, then the image may or may not contain burned in annotation. Enumerated Values: YES, NO.
Lossy Image Compression	(0028,2110)	-	3	Specifies whether an Image has undergone lossy compression. Enumerated Values: 00 = Image has NOT been subjected to lossy compression, 01 = Image has been subjected to lossy compression.
Lossy Image Compression Ratio	(0028,2112)	-	3	Describes the approximate lossy compression ratio(s) that have been applied to this image. May be multi valued if successive lossy compression steps have been applied.
CSA Data Type	(0029,xx08)	SIEMENS CSA NON-IMAGE	1	CSA Data identification characteristics. Defined Terms: BSR REPORT = Study Report Data RT3D CONFIG = InSpaceIS Data
CSA Data Version	(0029,xx09)	SIEMENS CSA NON-IMAGE	3	Version of CSA Data Info (0029,xx10) format and CSA Non-Image Data (7FE1,xx10) format.
CSA Data Info	(0029,xx10)	SIEMENS CSA NON-IMAGE	3	Information to describe the CSA Data (7FE1,xx10).
CSA Data	(7FE1,xx10)	SIEMENS CSA NON-IMAGE	2	Binary data as byte stream.

Table 75 CSA Non-Image Attributes

**A.2 Siemens Standard Extended Modules**

IE	Module	Reference	Usage	Note
Image	CSA Image Header	A.2.1	U	private GG information
	CSA Series Header	A.2.2	U	
	MEDCOM Header	A.2.3	U	private <i>syngo</i> information
	MEDCOM OOG	A.2.4	U	if object graphics is attached to image
	Edge Enhancement	A.2.5	U	private Filter Information
	Angio Viewing	A.2.6	U	private Viewing information
	Angio Acquisition	A.2.7	U	additional private Information about image Acquisition
	Angio Quantification	A.2.8	U	if image is a Quant Report
	Original Image Info	A.2.9	U	if derived image

Table 76 CSA Image IOD Modules

**A.2.1 MEDCOM Header Module**

The table in this section contains private IOD Attributes that describe MEDCOM Header:

Attribute Name	Tag	Owner	Type	Notes
MedCom Header Type	(0029,xx08)	SIEMENS MEDCOM HEADER	1C	MedCom Header identification characteristics. Defined Terms: MEDCOM 1 (Required if MedCom Header Info (0029,xx10) present.)
MedCom Header Version	(0029,xx09)	SIEMENS MEDCOM HEADER	2C	Version of MedCom Header Info (0029,xx10) format. (Required if MEDCOM Header Info (0029,xx10) present.)
MedCom Header Info	(0029,xx10)	SIEMENS MEDCOM HEADER	3	Manufacturer model dependent information. The value of the attribute MedCom Header Info (0029,xx10) can be build up in any user defined format.
MedCom History Information	(0029,xx20)	SIEMENS MEDCOM HEADER	3	MedCom defined Patient Registration history information. See A.2.3.1.
PMTF Information 1	(0029,xx31)	SIEMENS MEDCOM HEADER	3	Transformation Information
PMTF Information 2	(0029,xx32)	SIEMENS MEDCOM HEADER	3	Transformation Information
PMTF Information 3	(0029,xx33)	SIEMENS MEDCOM HEADER	3	Transformation Information
PMTF Information 4	(0029,xx34)	SIEMENS MEDCOM HEADER	3	Transformation Information
PMTF Information 5	(0029,xx35)	SIEMENS MEDCOM HEADER	3	Transformation Information
Application Header Sequence	(0029,xx40)	SIEMENS MEDCOM HEADER	3	Sequence of Application Header items. Zero or more items are possible.
>Application Header Type	(0029,xx41)	SIEMENS MEDCOM HEADER	1C	Application Header identification characteristics. Required, if Sequence is sent.
>Application Header ID	(0029,xx42)	SIEMENS MEDCOM HEADER	3	Identification of an application header
>Application Header Version	(0029,xx43)	SIEMENS MEDCOM HEADER	3	Version of CSA Series Header Info (0029,xx44) format.
>Application Header Info	(0029,xx44)	SIEMENS MEDCOM HEADER	3	Application dependent information.
Workflow Control Flags	(0029,xx50)	SIEMENS MEDCOM HEADER	3	Eight free definable flags.
Archive Management Flag Keep Online	(0029,xx51)	SIEMENS MEDCOM HEADER	3	Flag to control remote archive management system to keep the image always online (also when already archived). Enumerated Values: 00 = remote control not required 01 = keep image online
Archive Management Flag Do Not Archive	(0029,xx52)	SIEMENS MEDCOM HEADER	3	Flag to control remote archive management system not to archive the related image. Enumerated Values: 00 = remote control not required 01 = don't archive image
Image Location Status	(0029,xx53)	SIEMENS MEDCOM HEADER	3	Image location status to control retrieving. Defined Terms: ONLINE = retrieving has to be done as usual, NEARLINE = move request to SCP and delay according to value of Estimated Retrieve Time (0029,xx54), OFFLINE = invoking a retrieve operation initiates an operator request, INVALID = invoking a retrieve operation would always result in an error.

Attribute Name	Tag	Owner	Type	Notes
Estimated Retrieve Time	(0029,xx54)	SIEMENS MEDCOM HEADER	3	Estimated retrieve time in seconds. A value less than zero (< 0) indicates location is OFFLINE or INVALID.
Data Size of Retrieved Images	(0029,xx55)	SIEMENS MEDCOM HEADER	3	Data size of images in MByte.
Series Workflow Status	(0029,xx60)	SIEMENS MEDCOM HEADER2	3	

Table 77 MEDCOM Header Modules

### A.2.1.1 MEDCOM History Information

The value of the attribute MEDCOM History Information (0029,xx20) is defined in the following way:

Part	Name	Type	Bytes	Notes
header	Identifier	string	32	Always "CSA HISTORY"
	Version	string	32	e.g. "V1.10"
n Items	Class Name	string	64	
	Modification String	string	1024	

Table 78 MEDCOM History Information

### A.2.2 MEDCOM OOG Module

The table in this section contains private IOD Attributes that describe MEDCOM Object Oriented Graphics (OOG). This module is used whenever object graphics is drawn on the image and need to be stored as graphic object properties. Given the condition that the module contents was not removed by other modalities, the graphic objects remain re-animatable if such an image was transferred and is then retrieved back

Attribute Name	Tag	Owner	Type	Notes
MedCom OOG Type	(0029,xx08)	SIEMENS MEDCOM OOG	1	MEDCOM Object Oriented Graphics (OOG) identification characteristics. Defined Terms: MEDCOM OOG 1 MEDCOM OOG 2
MedCom OOG Version	(0029,xx09)	SIEMENS MEDCOM OOG	3	Version of MEDCOM OOG Info (0029,xx10) format.
MedCom OOG Info	(0029,xx10)	SIEMENS MEDCOM OOG	3	MEDCOM Object Oriented Graphics (OOG) data.

Table 79 MEDCOM OOG Module

The graphics objects are also fully drawn in the Image Overlay Plane for compatibility with other products, which do not support the MedCom OOG module. Any system not supporting the MedCom OOG module shall remove the OOG module and its content when modifying the image overlay plane content.

### A.2.3 Edge Enhancement Module

The table in this section contains private IOD Attributes that describe Edge Enhancement extensions due to the Dynamic Cardio Review definition.

Attribute Name	Tag	Owner	Type	Notes
Standard Edge Enhancement Sequence	(0029,xx00)	CARDIO-D.R. 1.0	3	Standard formula according to Dynaview Extensions.
>Convolution Kernel Size	(0029,xx01)	CARDIO-D.R. 1.0	1C	x-/y-size value pair. Each value shall be greater or equal to 3. Required if sequence is present
>Convolution Kernel Coefficients	(0029,xx02)	CARDIO-D.R. 1.0	1C	Row-by-row list of the kernel Coefficients. Required if sequence is present
>Edge Enhancement Gain	(0029,xx03)	CARDIO-D.R. 1.0	1C	Applied Filter gain Factor. Range is from 0 to 100 Percent. Required if sequence is present

Table 80 Edge Enhancement Module

### A.2.4 Angio Viewing Module

The table in this section contains private IOD Attributes that describe additional Attributes for advanced Angio Viewing features

Attribute Name	Tag	Owner	Type	Notes
Review Mode	(0019,xx00)	SIEMENS SMS-AX VIEW 1.0	3	Special Modes for Angio Review. Defined Terms are 1 = REV_MAXFILL, 2 = REV_LOOP, 3 = REV_SCROLL, 4 = REV_STEREO_LOOP
Anatomical Background Percent	(0019,xx01)	SIEMENS SMS-AX VIEW 1.0	3	Percentage of Mix between Subtracted Image Result and Native Mask. Range is from 0 to 100.
Number of Phases	(0019,xx02)	SIEMENS SMS-AX VIEW 1.0	3	1-4 (1 or # of "Variable Frame Rate" acq phases)
Apply Anatomical Background	(0019,xx03)	SIEMENS SMS-AX VIEW 1.0	3	boolean
Pixel Shift Array	(0019,xx04)	SIEMENS SMS-AX VIEW 1.0	3	4 * Number of Frames (0028,0008)
Brightness	(0019,xx05)	SIEMENS SMS-AX VIEW 1.0	3	SUB windowing
Contrast	(0019,xx06)	SIEMENS SMS-AX VIEW 1.0	3	SUB windowing
Enabled Shutter	(0019,xx07)	SIEMENS SMS-AX VIEW 1.0	3	Visualize shutter
Native Edge Enhancement Percent Gain	(0019,xx08)	SIEMENS SMS-AX VIEW 1.0	3	Percent gain for native display of images.
Native Edge Enhancement LUT Index	(0019,xx09)	SIEMENS SMS-AX VIEW 1.0	3	
Native Edge Enhancement Kernel Size	(0019,xx0A)	SIEMENS SMS-AX VIEW 1.0	3	
Subtracted Edge Enhancement Percent Gain	(0019,xx0B)	SIEMENS SMS-AX VIEW 1.0	3	Percent gain for subtracted display of images.
Subtracted Edge Enhancement LUT Index	(0019,xx0C)	SIEMENS SMS-AX VIEW 1.0	3	
Subtracted Edge Enhancement Kernel Size	(0019,xx0D)	SIEMENS SMS-AX VIEW 1.0	3	

Fade Percent	(0019,xx0E)	SIEMENS SMS-AX VIEW 1.0	3	
Attribute Name	Tag	Owner	Type	Notes
Flipped before Laterality Applied	(0019,xx0F)	SIEMENS SMS-AX VIEW 1.0	3	
Apply Fade	(0019,xx10)	SIEMENS SMS-AX VIEW 1.0	3	
Zoom	(0019,xx12)	SIEMENS SMS-AX VIEW 1.0	3	
Pan X	(0019,xx13)	SIEMENS SMS-AX VIEW 1.0	3	
Pan Y	(0019,xx14)	SIEMENS SMS-AX VIEW 1.0	3	
Native Edge Enhancement Adverse Percent Gain	(0019,xx15)	SIEMENS SMS-AX VIEW 1.0	3	
Subtracted Edge Enhancement Adverse Percent Gain	(0019,xx16)	SIEMENS SMS-AX VIEW 1.0	3	
Invert Flag	(0019,xx17)	SIEMENS SMS-AX VIEW 1.0	3	
Quant 1K Overlay	(0019,xx1A)	SIEMENS SMS-AX VIEW 1.0	3	Only Store Monitor and Store Reference Images in Quant (128 kbyte)

Table 81 Angio Viewing Module

### A.2.5 Angio Acquisition Data Module

The table in this section contains private IOD Attributes that describe additional Attributes for saving specific Angio Acquisition data.

Attribute Name	Tag	Owner	Type	Notes
Acquisition Type	(0021,xx00)	SIEMENS SMS-AX ACQ 1.0	3	Technical Type of Acquisition performed to get image result. Defined Terms are 1 = fixed frame rate, 2 = variable frame rate (manually trigrd), 3 = variable frame rate (time triggered), 4 = peri manual to head, 5 = peri slow speed to head, 6 = peri fast speed to head, 7 = peri manual to feet, 8 = peri slow speed to feet, 9 = peri fast speed to feet, 10 = dynavision manual inject., 11 = dynavision automatic, 12 = direct technique, 13 = continuous fluoro, 14 = pulsed fluoro, 15 = ECG triggered fluoro
Acquisition Mode	(0021,xx01)	SIEMENS SMS-AX ACQ 1.0	3	Technical Mode of Acquisition performed to get image result. Defined Terms are: 0 = no mode specified, 1 = Digital Radiographie, 2 = DSA, 3 = Peri-DSA, 4 = DR stepping, 5 = DR Dynavision (nat), 6 = Dynavision (sub), 7 = Card, 8 = Direct technique, 20 = Roadmap Fluoro, 21 = Normal Fluoro, 22 = Card Fluoro
Foot Switch Index	(0021,xx02)	SIEMENS SMS-AX ACQ 1.0	3	

Acquisition Room	(0021,xx03)	SIEMENS SMS-AX ACQ 1.0	3	
Attribute Name	Tag	Owner	Type	Notes
Current Time Product	(0021,xx04)	SIEMENS SMS-AX ACQ 1.0	3	(uAs)
Dose	(0021,xx05)	SIEMENS SMS-AX ACQ 1.0	3	(uGy/pulse)
Skin Dose Percent	(0021,xx06)	SIEMENS SMS-AX ACQ 1.0	3	
Skin Dose Accumulation	(0021,xx07)	SIEMENS SMS-AX ACQ 1.0	3	mGy
Skin Dose Rate	(0021,xx08)	SIEMENS SMS-AX ACQ 1.0	3	Percent gain for native display of images.
Copper Filter	(0021,xx0A)	SIEMENS SMS-AX ACQ 1.0	3	
Measuring Field	(0021,xx0B)	SIEMENS SMS-AX ACQ 1.0	3	Decimal values are defined as follows: 1 = left 2 = middle (rectangular) 3 = left and middle 4 = right 5 = left and right 6 = right and middle 7 = left and right and middle 8 = central (approx. round) 9 = left and central 12 = right and central 13 = left and right and central
Post Blanking Circle	(0021,xx0C)	SIEMENS SMS-AX ACQ 1.0	3	left edge, upper edge, radius
Dyna Angles	(0021,xx0D)	SIEMENS SMS-AX ACQ 1.0	3	May be used in previous versions. Data is now encoded in Standard attributes.
Total Steps	(0021,xx0E)	SIEMENS SMS-AX ACQ 1.0	3	Number of Images which make up a Peri or DR-Step acquisition
Dyna X-Ray Info	(0021,xx0F)	SIEMENS SMS-AX ACQ 1.0	3	Multiplicity of (3 * Number of Frames). (kV value, uA value, ms value) Only with Dyna Images
Gamma Input	(0021,xx10)	SIEMENS SMS-AX ACQ 1.0	3	
Gamma Output	(0021,xx11)	SIEMENS SMS-AX ACQ 1.0	3	
SH_STPAR	(0021,xx12)	SIEMENS SMS-AX ACQ 1.0	3	1st Byte = version. Technical data-structure with Gantry information.
Acquisition Zoom	(0021,xx13)	SIEMENS SMS-AX ACQ 1.0	3	0 = Off, 1 = On. Not to be mixed up with digital zoom from Viewing module.
Dyna Angulation Step Width	(0021,xx14)	SIEMENS SMS-AX ACQ 1.0	3	Only with Dyna Images
Harmonization	(0021,xx15)	SIEMENS SMS-AX ACQ 1.0	3	
DR Single Flag	(0021,xx16)	SIEMENS SMS-AX ACQ 1.0	3	1 = DR SINGLE, else single Frame DR acquisition
Source to Isocenter	(0021,xx17)	SIEMENS SMS-AX ACQ 1.0	3	(mm)
Pressure Data	(0021,xx18)	SIEMENS SMS-AX ACQ 1.0	3	
ECG Index Array	(0021,xx19)	SIEMENS SMS-AX ACQ 1.0	3	
FD Flag	(0021,xx1A)	SIEMENS SMS-AX ACQ 1.0	3	
SH_ZOOM	(0021,xx1B)	SIEMENS SMS-AX ACQ 1.0	3	1st Byte = version. Technical data-structure with Gantry information.
SH_COLPAR	(0021,xx1C)	SIEMENS SMS-AX ACQ 1.0	3	1st Byte = version. Technical data-structure with Gantry information.
K-Factor	(0021,xx1D)	SIEMENS SMS-AX ACQ 1.0	3	
EVE	(0021,xx1E)	SIEMENS SMS-AX ACQ 1.0	3	
Total Scene Time	(0021,xx1F)	SIEMENS SMS-AX ACQ 1.0	3	

Restore Flag	(0021,xx20)	SIEMENS SMS-AX ACQ 1.0	3	
Attribute Name	Tag	Owner	Type	Notes
Stand Movement Flag	(0021,xx21)	SIEMENS SMS-AX ACQ 1.0	3	
FD Rows	(0021,xx22)	SIEMENS SMS-AX ACQ 1.0	3	
FD Columns	(0021,xx23)	SIEMENS SMS-AX ACQ 1.0	3	
Table Movement Flag	(0021,xx24)	SIEMENS SMS-AX ACQ 1.0	3	

Table 82 Angio Acquisition Data Module

### A.2.6 Angio Quantitation Module

The table in this section contains private IOD Attributes that describe additional Attributes for advanced Angio Quantitation and Calibration Results features

Attribute Name	Tag	Owner	Type	Notes
Horizontal Calibration Pixel Size	(0023,xx00)	SIEMENS SMS-AX QUANT 1.0	3	(in mm)
Vertical Calibration Pixel Size	(0023,xx01)	SIEMENS SMS-AX QUANT 1.0	3	(in mm)
Calibration Object	(0023,xx02)	SIEMENS SMS-AX QUANT 1.0	3	
Calibration Object Size	(0023,xx03)	SIEMENS SMS-AX QUANT 1.0	3	
Calibration Method	(0023,xx04)	SIEMENS SMS-AX QUANT 1.0	3	
Filename	(0023,xx05)	SIEMENS SMS-AX QUANT 1.0	3	
Frame Number	(0023,xx06)	SIEMENS SMS-AX QUANT 1.0	3	
Calibration Factor Multiplicity	(0023,xx07)	SIEMENS SMS-AX QUANT 1.0	3	Multiplicity Horizontal followed by Multiplicity for Vertical

Table 83 Angio Quantitation Module

**A.2.7 Original Image Info Module**

The table in this section contains private IOD Attributes that describe additional original image data for derived images (e.g. Store Monitor Image).

Attribute Name	Tag	Owner	Type	Notes
View Native	(0025,xx00)	SIEMENS SMS-AX ORIGINAL IMAGE INFO 1.0	3	
Original Series Number	(0025,xx01)	SIEMENS SMS-AX ORIGINAL IMAGE INFO 1.0	3	
Original Image Number	(0025,xx02)	SIEMENS SMS-AX ORIGINAL IMAGE INFO 1.0	3	
Win Center	(0025,xx03)	SIEMENS SMS-AX ORIGINAL IMAGE INFO 1.0	3	
Win Width	(0025,xx04)	SIEMENS SMS-AX ORIGINAL IMAGE INFO 1.0	3	
Win Brightness	(0025,xx05)	SIEMENS SMS-AX ORIGINAL IMAGE INFO 1.0	3	
Win Contrast	(0025,xx06)	SIEMENS SMS-AX ORIGINAL IMAGE INFO 1.0	3	
Original Frame Number	(0025,xx07)	SIEMENS SMS-AX ORIGINAL IMAGE INFO 1.0	3	
Original Mask Frame Number	(0025,xx08)	SIEMENS SMS-AX ORIGINAL IMAGE INFO 1.0	3	
Opac	(0025,xx09)	SIEMENS SMS-AX ORIGINAL IMAGE INFO 1.0	3	
Original Number of Frames	(0025,xx0A)	SIEMENS SMS-AX ORIGINAL IMAGE INFO 1.0	3	
Original Scene Duration	(0025,xx0B)	SIEMENS SMS-AX ORIGINAL IMAGE INFO 1.0	3	
Identifier LOID	(0025,xx0C)	SIEMENS SMS-AX ORIGINAL IMAGE INFO 1.0	3	
Original Scene VFR Info	(0025,xx0D)	SIEMENS SMS-AX ORIGINAL IMAGE INFO 1.0	3	Number of phases, then followed by n pairs (LastFrameNumber, then Frame Rate)
Original Frame ECG Position	(0025,xx0E)	SIEMENS SMS-AX ORIGINAL IMAGE INFO 1.0	3	
Original ECG 1st Frame Offset	(0025,xx0F)	SIEMENS SMS-AX ORIGINAL IMAGE INFO 1.0	3	<retired, no longer used>
Zoom Flag	(0025,xx10)	SIEMENS SMS-AX ORIGINAL IMAGE INFO 1.0	3	
<i>reserved</i>	(0025,xx11)	SIEMENS SMS-AX ORIGINAL IMAGE INFO 1.0	-	
Number of Mask Frames	(0025,xx12)	SIEMENS SMS-AX ORIGINAL IMAGE INFO 1.0	3	
Number of Fill Frames	(0025,xx13)	SIEMENS SMS-AX ORIGINAL IMAGE INFO 1.0	3	

Table 84 Original Image Info Module

**A.2.8 SOP Common Module – Image Type Extentions**

Additional values for the image type attribute are used to designate the purpose of the SOP instance created by the AXIOM Artis system. Please see the following table for details.

Type of Scene/Image	Image Type
Single Plane Scene	ORIGINAL\PRIMARY\SINGLE PLANE\SINGLE A (or B)
Biplane Scene	ORIGINAL\PRIMARY\BIPLANE A (or B)
Reference Image	DERIVED\SECONDARY\SINGLE PLANE\SINGLE A(B)\REFIMAGE
Reference Image from CT	DERIVED\SECONDARY\SINGLE PLANE\SINGLE A\REFIMAGE\CT REF
Reference Image from MR	DERIVED\SECONDARY\SINGLE PLANE\SINGLE A\REFIMAGE\MR REF
Dynamic Reference Image (Dynamap)	DERIVED\SECONDARY\SINGLE PLANE\SINGLE A(B)\DYNAMAP
Store Monitor	DERIVED\SECONDARY\SINGLE PLANE\SINGLE A(B)\STORE MONITOR
Secondary Capture	DERIVED\SECONDARY\SINGLE PLANE\PLANE A(B)\SC
Perivision - Mask Phase	ORIGINAL\PRIMARY\SINGLE PLANE\PLANE A\PER\MASK\ <sup>n</sup>
Perivision - Fill Phase	ORIGINAL\PRIMARY\SINGLE PLANE\PLANE A\PER\FILL\ <sup>n</sup>
Dynavision - Mask Phase	ORIGINAL\PRIMARY\SINGLE PLANE\PLANE A\DYNA\MASK
Dynavision - Fill Phase	ORIGINAL\PRIMARY\SINGLE PLANE\PLANE A\DYNA\FILL
Dynavision - Injection Phase	ORIGINAL\PRIMARY\SINGLE PLANE\PLANE A\DYNA\INJECTION
Dynavision - Washout Phase	ORIGINAL\PRIMARY\SINGLE PLANE\PLANE A\DYNA\WASHOUT
Store Fluoro Loop	DERIVED\PRIMARY\SINGLE PLANE\SINGLE A(or B)\STORE FLUORO
Store Biplan Fluoro Loop	DERIVED\PRIMARY\BIPLANE A(or B)\STORE FLUORO
Quant Result Image	DERIVED\SECONDARY\<3rd to nth value from Original>\QUANT
Study Report (Non-Image Object)	ORIGINAL\PRIMARY\SINGLE PLANE\STUDY REPORT

<sup>1</sup> the term "n" is replaced by the related Step Number where the Image was acquired. Step Numbers start with "1".

Table 85 Image Type Extentions

**A.3 Registry of private DICOM Data Elements**

Tag	Private Owner Code	Name	VR	VM
(0019,xx00)	SIEMENS SMS-AX VIEW 1.0	Review Mode	US	1
(0019,xx01)	SIEMENS SMS-AX VIEW 1.0	Anatomical Background Percent	US	1
(0019,xx02)	SIEMENS SMS-AX VIEW 1.0	Number of Phases	US	1
(0019,xx03)	SIEMENS SMS-AX VIEW 1.0	Apply Anatomical Background	US	1
(0019,xx04)	SIEMENS SMS-AX VIEW 1.0	Pixelshift Array	SS	4-4n
(0019,xx05)	SIEMENS SMS-AX VIEW 1.0	Brightness	US	1
(0019,xx06)	SIEMENS SMS-AX VIEW 1.0	Contrast	US	1
(0019,xx07)	SIEMENS SMS-AX VIEW 1.0	Enabled	US	1
(0019,xx08)	SIEMENS SMS-AX VIEW 1.0	Native Edge Enh. Percent Gain	US	1
(0019,xx09)	SIEMENS SMS-AX VIEW 1.0	Native Edge Enh. LUT Index	SS	1
(0019,xx0A)	SIEMENS SMS-AX VIEW 1.0	Native Edge Enh. Kernel Size	SS	1
(0019,xx0B)	SIEMENS SMS-AX VIEW 1.0	Subtr. Edge Enh. Percent Gain	US	1
(0019,xx0C)	SIEMENS SMS-AX VIEW 1.0	Subtr. Edge Enh. LUT Index	SS	1
(0019,xx0D)	SIEMENS SMS-AX VIEW 1.0	Subtr. Edge Enh. Kernel Size	SS	1
(0019,xx0E)	SIEMENS SMS-AX VIEW 1.0	Fade Percent	US	1
(0019,xx0F)	SIEMENS SMS-AX VIEW 1.0	Flipped Befor Laterality Applied	US	1
(0019,xx10)	SIEMENS SMS-AX VIEW 1.0	Apply Fade	US	1
(0019,xx12)	SIEMENS SMS-AX VIEW 1.0	Zoom	US	1
(0019,xx13)	SIEMENS SMS-AX VIEW 1.0	Pan X	SS	1
(0019,xx14)	SIEMENS SMS-AX VIEW 1.0	Pan Y	SS	1
(0019,xx15)	SIEMENS SMS-AX VIEW 1.0	Native Edge Enh. Adv Perc. Gain	SS	1
(0019,xx16)	SIEMENS SMS-AX VIEW 1.0	Subtr. Edge Enh. Adv Perc. Gain	SS	1
(0019,xx17)	SIEMENS SMS-AX VIEW 1.0	Invert Flag	US	1
(0019,xx1A)	SIEMENS SMS-AX VIEW 1.0	Quant 1K Overlay	OB	1

Table 86 Private Elements in Group 0019

Tag	Private Owner Code	Name	VR	VM
(0021,xx00)	SIEMENS SMS-AX ACQ 1.0	Acquisition Type	US	1
(0021,xx01)	SIEMENS SMS-AX ACQ 1.0	Acquisition Mode	US	1
(0021,xx02)	SIEMENS SMS-AX ACQ 1.0	Footswitch Index	US	1
(0021,xx03)	SIEMENS SMS-AX ACQ 1.0	Acquisition Room	US	1
(0021,xx04)	SIEMENS SMS-AX ACQ 1.0	Current Time Product	SL	1
(0021,xx05)	SIEMENS SMS-AX ACQ 1.0	Dose	SL	1
(0021,xx06)	SIEMENS SMS-AX ACQ 1.0	Skin Dose Percent	SL	1
(0021,xx07)	SIEMENS SMS-AX ACQ 1.0	Skin Dose Accumulation	SL	1
(0021,xx08)	SIEMENS SMS-AX ACQ 1.0	Skin Dose Rate	SL	1
(0021,xx0A)	SIEMENS SMS-AX ACQ 1.0	Copper Filter	UL	1
(0021,xx0B)	SIEMENS SMS-AX ACQ 1.0	Measuring Field	US	1
(0021,xx0C)	SIEMENS SMS-AX ACQ 1.0	Post Blanking Circle	SS	3
(0021,xx0D)	SIEMENS SMS-AX ACQ 1.0	Dyna Angles	SS	2-2n
(0021,xx0E)	SIEMENS SMS-AX ACQ 1.0	Total Steps	SS	1
(0021,xx0F)	SIEMENS SMS-AX ACQ 1.0	Dyna X-Ray Info	SL	3-3n
(0021,xx10)	SIEMENS SMS-AX ACQ 1.0	Modality LUT Input Gamma	ÚS	1
(0021,xx11)	SIEMENS SMS-AX ACQ 1.0	Modality LUT Output Gamma	US	1
(0021,xx12)	SIEMENS SMS-AX ACQ 1.0	SH_STPAR	OB	1-n
(0021,xx13)	SIEMENS SMS-AX ACQ 1.0	Acquisition Zoom	US	1
(0021,xx14)	SIEMENS SMS-AX ACQ 1.0	Dyna Angulation Step Width	SS	1
(0021,xx15)	SIEMENS SMS-AX ACQ 1.0	Harmonization	US	1
(0021,xx16)	SIEMENS SMS-AX ACQ 1.0	DR Single Flag	US	1

Tag	Private Owner Code	Name	VR	VM
(0021,xx17)	SIEMENS SMS-AX ACQ 1.0	Source to Isocenter	SL	1
(0021,xx18)	SIEMENS SMS-AX ACQ 1.0	Pressure Data	US	1
(0021,xx19)	SIEMENS SMS-AX ACQ 1.0	ECG Index Array	SL	1
(0021,xx1A)	SIEMENS SMS-AX ACQ 1.0	FD Flag	US	1
(0021,xx1B)	SIEMENS SMS-AX ACQ 1.0	SH_ZOOM	OB	1
(0021,xx1C)	SIEMENS SMS-AX ACQ 1.0	SH_COLPAR	OB	1
(0021,xx1D)	SIEMENS SMS-AX ACQ 1.0	K-Factor	US	1
(0021,xx1E)	SIEMENS SMS-AX ACQ 1.0	EVE	US	8
(0021,xx1F)	SIEMENS SMS-AX ACQ 1.0	Total Scene Time	SL	1
(0021,xx20)	SIEMENS SMS-AX ACQ 1.0	Restore Flag	US	1
(0021,xx21)	SIEMENS SMS-AX ACQ 1.0	Stand Movement Flag	US	1
(0021,xx22)	SIEMENS SMS-AX ACQ 1.0	FD Rows	US	1
(0021,xx23)	SIEMENS SMS-AX ACQ 1.0	FD Columns	US	1
(0021,xx24)	SIEMENS SMS-AX ACQ 1.0	Table Movement Flag	US	1

Table 87 Private Elements in Group 0021

Tag	Private Owner Code	Name	VR	VM
(0023,xx00)	SIEMENS SMS-AX QUANT 1.0	Horizontal Calibration Pixel Size	DS	2
(0023,xx01)	SIEMENS SMS-AX QUANT 1.0	Vertical Calibration Pixel Size	DS	2
(0023,xx02)	SIEMENS SMS-AX QUANT 1.0	Calibration Object	LO	1
(0023,xx03)	SIEMENS SMS-AX QUANT 1.0	Calibration Object Size	DS	1
(0023,xx04)	SIEMENS SMS-AX QUANT 1.0	Calibration Method	LO	1
(0023,xx05)	SIEMENS SMS-AX QUANT 1.0	Filename	ST	1
(0023,xx06)	SIEMENS SMS-AX QUANT 1.0	Frame Number	IS	1
(0023,xx07)	SIEMENS SMS-AX QUANT 1.0	Calibration Factor Multiplicity	IS	2

Table 88 Private Elements in Group 0023

Tag	Private Owner Code	Name	VR	VM
(0025,xx00)	SIEMENS SMS-AX ORIGINAL IMAGE INFO 1.0	View Native	US	1
(0025,xx01)	SIEMENS SMS-AX ORIGINAL IMAGE INFO 1.0	Original Series Number	US	1
(0025,xx02)	SIEMENS SMS-AX ORIGINAL IMAGE INFO 1.0	Original Image Number	US	1
(0025,xx03)	SIEMENS SMS-AX ORIGINAL IMAGE INFO 1.0	Win Center	US	1
(0025,xx04)	SIEMENS SMS-AX ORIGINAL IMAGE INFO 1.0	Win Width	US	1
(0025,xx05)	SIEMENS SMS-AX ORIGINAL IMAGE INFO 1.0	Win Brightness	US	1
(0025,xx06)	SIEMENS SMS-AX ORIGINAL IMAGE INFO 1.0	Win Contrast	US	1
(0025,xx07)	SIEMENS SMS-AX ORIGINAL IMAGE INFO 1.0	Original Frame Number	US	1
(0025,xx08)	SIEMENS SMS-AX ORIGINAL IMAGE INFO 1.0	Original Mask Frame Number	US	1
(0025,xx09)	SIEMENS SMS-AX ORIGINAL IMAGE INFO 1.0	Opac	US	1
(0025,xx0A)	SIEMENS SMS-AX ORIGINAL IMAGE INFO 1.0	Original Number of Frames	US	1
(0025,xx0B)	SIEMENS SMS-AX ORIGINAL IMAGE INFO 1.0	Original Scene Duration	DS	1
(0025,xx0C)	SIEMENS SMS-AX ORIGINAL IMAGE INFO 1.0	Identifier LOID	LO	1
(0025,xx0D)	SIEMENS SMS-AX ORIGINAL IMAGE INFO 1.0	Original Scene VFR Info	SS	1-n
(0025,xx0E)	SIEMENS SMS-AX ORIGINAL IMAGE INFO 1.0	Original Frame ECG Position	SS	1

Tag	Private Owner Code	Name	VR	VM
(0025,xx0F)	SIEMENS SMS-AX ORIGINAL IMAGE INFO 1.0	Original ECG 1st Frame Offset(retired)	SS	1
(0025,xx10)	SIEMENS SMS-AX ORIGINAL IMAGE INFO 1.0	Zoom Flag	SS	1
(0025,xx11)	SIEMENS SMS-AX ORIGINAL IMAGE INFO 1.0	<i>reserved</i>	-	-
(0025,xx12)	SIEMENS SMS-AX ORIGINAL IMAGE INFO 1.0	Number of Mask Frames	US	1
(0025,xx13)	SIEMENS SMS-AX ORIGINAL IMAGE INFO 1.0	Number of Fill Frames	US	1

Table 89 Private Elements in Group 0025

Tag	Private Owner Code	Name	VR	VM
(0029,xx08)	SIEMENS CSA NON-IMAGE	CSA Data Type	CS	1
(0029,xx09)	SIEMENS CSA NON-IMAGE	CSA Data Version	LO	1
(0029,xx10)	SIEMENS CSA NON-IMAGE	CSA Data Info	OB	1
(0029,xx08)	SIEMENS MEDCOM HEADER	MedCom Header Type	CS	1
(0029,xx09)	SIEMENS MEDCOM HEADER	MedCom Header Version	LO	1
(0029,xx10)	SIEMENS MEDCOM HEADER	MedCom Header Info	OB	1
(0029,xx20)	SIEMENS MEDCOM HEADER	MedCom History Information	OB	1
(0029,xx31)	SIEMENS MEDCOM HEADER	PMTF Information 1	LO	1
(0029,xx32)	SIEMENS MEDCOM HEADER	PMTF Information 2	UL	1
(0029,xx33)	SIEMENS MEDCOM HEADER	PMTF Information 3	UL	1
(0029,xx34)	SIEMENS MEDCOM HEADER	PMTF Information 4	CS	1
(0029,xx35)	SIEMENS MEDCOM HEADER	PMTF Information 5	UL	1
(0029,xx40)	SIEMENS MEDCOM HEADER	Application Header Sequence	SQ	1
(0029,xx41)	SIEMENS MEDCOM HEADER	Application Header Type	CS	1
(0029,xx42)	SIEMENS MEDCOM HEADER	Application Header ID	LO	1
(0029,xx43)	SIEMENS MEDCOM HEADER	Application Header Version	LO	1
(0029,xx44)	SIEMENS MEDCOM HEADER	Application Header Info	OB	1
(0029,xx50)	SIEMENS MEDCOM HEADER	Workflow Control Flags	LO	8
(0029,xx51)	SIEMENS MEDCOM HEADER	Arch. Management Flag Keep Online	CS	1
(0029,xx52)	SIEMENS MEDCOM HEADER	Arch. Mgmtnt Flag Do Not Archive	CS	1
(0029,xx53)	SIEMENS MEDCOM HEADER	Image Location Status	CS	1
(0029,xx54)	SIEMENS MEDCOM HEADER	Estimated Retrieve Time	DS	1
(0029,xx55)	SIEMENS MEDCOM HEADER	Data Size of Retrieved Images	DS	1
(0029,xx60)	SIEMENS MEDCOM HEADER2	Series Workflow Status	LO	1
(0029,xx08)	SIEMENS MEDCOM OOG	MedCom OOG Type	CS	1
(0029,xx09)	SIEMENS MEDCOM OOG	MedCom OOG Version	LO	1
(0029,xx10)	SIEMENS MEDCOM OOG	MedCom OOG Info	OB	1
(0029,xx00)	CARDIO-D.R. 1.0	Standard Edge Enhancement Sequence	SQ	1
(0029,xx01)	CARDIO-D.R. 1.0	Convolution Kernel Size	US	2
(0029,xx02)	CARDIO-D.R. 1.0	Convolution Kernel Coefficients	US	1-n
(0029,xx03)	CARDIO-D.R. 1.0	Edge Enhancement Gain	FL	1
(7FE1,xx10)	SIEMENS CSA NON-IMAGE	CSA Data	OB	1

Table 90 Private Elements in Group 0029 and 7FE1

**Note**

Please be informed that some of the Private Owner Codes contain double-spaces in the name definitions. The following terms (only double-spaces marked) are defined:

SIEMENS SMS-AX<spc><spc>VIEW 1.0, SIEMENS SMS-AX<spc><spc>ACQ 1.0,

SIEMENS SMS-AX<spc><spc>QUANT 1.0, SIEMENS SMS-AX<spc><spc>ORIGINAL IMAGE  
INFO 1.0 All spaces not specially marked, are single spaces.

**A.4 Extended XA IOD**

The AXIOM Artis system will create images during acquisition and with post processing applications. Those will be encoded as XA Standard Extended SOP Class. Images created during post processing will be marked as derived. Please see the following table for a complete overview of supplied Type 1/2/3 Standard and additional Private Attributes:

The Standard DICOM Modules will be used to encode ECG data.

Attribute Name	Tag	Value
Specific Character Set	(0008,0005)	From Configuration
Image Type	(0008,0008)	See "A.2.10. SOP Common Module-Image Type Extensions"
SOP Class UID	(0008,0016)	1.2.840.10008.5.1.4.1.1.12.1
SOP Instance UID	(0008,0018)	
Study Date	(0008,0020)	<yyyymmdd>
Series Date	(0008,0021)	<yyyymmdd>
Acquisition Date	(0008,0022)	Original: same as Content Date Derived: Date of Original Acquisition
Content Date	(0008,0023)	<yyyymmdd> (Date of Creation)
Study Time	(0008,0030)	<hhmmss>
Series Time	(0008,0031)	<hhmmss>
Acquisition Time	(0008,0032)	Time of Original Acquisition
Content Time	(0008,0033)	<hhmmss> (Time of Creation)
Accession Number	(0008,0050)	RIS or "Accession No." input
Modality	(0008,0060)	XA
Manufacturer	(0008,0070)	Siemens
Institution Name	(0008,0080)	RIS or "Institution Name" input
Institution Address	(0008,0081)	RIS
Referring Physician's Name	(0008,0090)	RIS or input
Station Name	(0008,1010)	from Configuration (VB22x or later)
Study Description	(0008,1030)	"Study" input
Series Description	(0008,103E)	"Organ Program" input or "Organ Program" + (REF)/(SM)/(FLM) or one of : STUDY REPORT, CARE GRAPH, QUANT or DYNAMAP
Physicians of Record	(0008,1048)	From RIS (0040,1010) Names of Intended Recipients of Results
Performing Physician's Name	(0008,1050)	"Performing Physician 1" "Performing Physician 2" input
Operator's Name	(0008,1070)	"Operator 1" "Operator 2" input
Admitting Diagnosis Description	(0008,1080)	"Admitting Diagnosis" input
Manufacturer's Model Name	(0008,1090)	AXIOM-Artis
Referenced Study Sequence	(0008,1110)	From RIS
>Referenced SOP Class UID	(0008,1150)	
>Referenced SOP Instance UID	(0008,1155)	
Referenced Patient Sequence	(0008,1120)	From RIS
>Referenced SOP Class UID	(0008,1150)	
>Referenced SOP Instance UID	(0008,1155)	
Referenced Image Sequence	(0008,1140)	Reference to related Plane with BIPLANE A/B Instances
>Referenced SOP Class UID	(0008,1150)	
>Referenced SOP Instance UID	(0008,1155)	
Derivation Description	(0008,2111)	Notes about transformation steps
Start Trim	(0008,2142)	<1 st frame to display>
Stop Trim	(0008,2143)	<last frame to display>

Attribute Name	Tag	Value
Recomm. Display Frame Rate	(0008,2144)	(in f/s)
Patient's Name	(0010,0010)	RIS or "Patient Name" input
Patient ID	(0010,0020)	RIS or "Patient ID" input
Patient's Birth Date	(0010,0030)	RIS or checked "DoB" input
Patient's Sex	(0010,0040)	RIS or input (M or F or O/unknown)
Other Patient IDs	(0010,1000)	From RIS
Other Patient Names	(0010,1001)	From RIS
Patient's Age	(0010,1010)	Calculated from "DoB" input
Patient's Size	(0010,1020)	(in meters)
Patient's Weight	(0010,1030)	(in kilograms)
Patient's Address	(0010,1040)	"Address" input
Military Rank	(0010,1080)	From RIS
Medical Alerts	(0010,2000)	From RIS
Contrast Allergies	(0010,2110)	From RIS
Ethnic Group	(0010,2160)	From RIS
Smoking Status	(0010,21A0)	From RIS
Additional Patient History	(0010,21B0)	From RIS
Pregnancy Status	(0010,21C0)	From RIS
Last Menstrual Date	(0010,21D0)	From RIS
Patient Comment	(0010,4000)	"Additional Info" input
Contrast/Bolus Agent	(0018,0010)	
Cine Rate	(0018,0040)	<acquired frame rate>
KVP	(0018,0060)	<peak KV used> (KV)
Device Serial Number	(0018,1000)	<modality serial number>
Software Version	(0018,1020)	
Protocol Name	(0018,1030)	"Organ Program" input
Contrast Bolus Ingredient	(0018,1048)	
Frame Time	(0018,1063)	(msec/frame)
Frame Time Vector	(0018,1065)	<number of Frame values>(msec)
Distance Source to Detector	(0018,1110)	(mm)
Distance Source to Patient	(0018,1111)	(mm)
Estimated Radiographic Magnification Factor	(0018,1114)	<Ratio of SID/SOD>
Exposure Time	(0018,1150)	<duration of x-Ray exposure>(msec)
X-Ray Tube Current	(0018,1151)	(mA)
Average Pulse Width	(0018,1154)	(msec)
Radiation Setting	(0018,1155)	SC   GR
Radiation Mode	(0018,115A)	CONTINUOUS   PULSED
Image Area Dose Product	(0018,115E)	(dGy*cm*cm)
Intensifier Size	(0018,1162)	<(zoomed) diameter> (mm)
Imager Pixel Spacing	(0018,1164)	<row space, col space>(mm)
Focal Spot	(0018,1190)	DYNAMIC   STATIC
Positioner Motion	(0018,1500)	(degrees); 0 with DYNAMIC
Positioner Primary Angle	(0018,1510)	(degrees); 0 with DYNAMIC
Positioner Secondary Angle	(0018,1511)	Only with DYNAMIC (absolute values)
Positioner Primary Angle Increment	(0018,1520)	Only with DYNAMIC (absolute values)
Positioner Secondary Angle Increment	(0018,1521)	RECTANGULAR and/or CIRCULAR and/or POLYGONAL
Shutter Shape	(0018,1600)	DYNAMIC   STATIC
Shutter Left Vertical Edge	(0018,1602)	<column number left edge>
Shutter Right Vertical Edge	(0018,1604)	<column number right edge>
Shutter Upper Horizontal Edge	(0018,1606)	<row number upper edge>
Shutter Lower Horizontal Edge	(0018,1608)	<row number lower edge>
Center of Circular Shutter	(0018,1610)	<row number>,<column number>
Radius of Circular Shutter	(0018,1612)	<number of pixels in row direction>

Attribute Name	Tag	Value
Vertices of the Polygonal Shutter	(0018,1620)	<list of row/column coordinate pairs>
Collimator Shape	(0018,1700)	RECTANGULAR and/or CIRCULAR and/or POLYGONAL
Collimator Left Vertical Edge	(0018,1702)	<column number left edge>
Collimator Right Vertical Edge	(0018,1704)	<column number right edge>
Collimator Upper Horizontal Edge	(0018,1706)	<row number upper edge>
Collimator Lower Horizontal Edge	(0018,1708)	<row number lower edge>
Center of Circular Collimator	(0018,1710)	<row number>,<column number>
Radius of Circular Collimator	(0018,1712)	<number of pixels in row direction>
Vertices of the Polygonal Collimator	(0018,1720)	<list of row/column coordinate pairs>
Patient Position	(0018,5100)	Mandatory "Patient Position" input
Private Creator	(0019,00xx)	SIEMENS SMS-AX VIEW 1.0
<i>Attributes according to "A.2.6 Angio Viewing Module"</i>		
Study Instance UID	(0020,000D)	RIS or system generated
Series Instance UID	(0020,000E)	
Study ID	(0020,0010)	
Series Number	(0020,0011)	
Instance Number	(0020,0013)	
Patient Orientation	(0020,0020)	calculated from "Patient Position" input and from Gantry coordinate data.
Laterality	(0020,0060)	input via L or R marker annotation, else absent
Images in Acquisition	(0020,1002)	
Image Comments	(0020,4000)	Not encoded or "SM" or "REF"
Private Creator	(0021,00xx)	SIEMENS SMS-AX ACQ 1.0
<i>Attributes according to "A.2.7 Angio Acquisition Data Module"</i>		
Private Creator	(0023,00xx)	SIEMENS SMS-AX QUANT 1.0
<i>Attributes according to "A.2.8 Angio Quantitation Module" if image was calibrated</i>		
Private Creator	(0025,00xx)	SIEMENS SMS-AX ORIGINAL IMAGE INFO 1.0
<i>Attributes according to "A.2.9 Original Image Info Module"</i>		
Samples per Pixel	(0028,0002)	1
Photometric Interpretation	(0028,0004)	MONOCHROME2
Number of Frames	(0028,0008)	
Frame Increment Pointer	(0028,0009)	(0018,1063) or (0018,1065) for VFR
Rows	(0028,0010)	Up to 1024
Columns	(0028,0011)	Up to 1024
Bits Allocated	(0028,0100)	8   16
Bits Stored	(0028,0101)	8   12
High Bit	(0028,0102)	7   11
Pixel Representation	(0028,0103)	0
Pixel Intensity Relationship	(0028,0103)	LIN   LOG   DISP
Window Center	(0028,1050)	<NAT value>
Window Width	(0028,1051)	<NAT value>
Recommended Viewing Mode	(0028,1090)	SUB   NAT
Lossy Image Compression	(0028,2110)	
Modality LUT sequence	(0028,3000)	(if [0028,1040] = LOG)
>LUT Descriptor	(0028,3002)	<num of LUT entries>, <first pixel val mapped>, <Entry bits alloc>
>Modality LUT Type	(0028,3004)	US
>LUT data	(0028,3006)	<array of data, accord. descriptor>
Representative Frame Number	(0028,6010)	<e.g. frame number of Icon Image>
Mask Subtraction Sequence	(0028,6100)	
>Mask Operation	(0028,6101)	AVG_SUB
>Mask Frame Number	(0028,6110)	(only for AVG_SUB)
Private Creator	(0029,00xx)	CARDIO-D.R. 1.0

Attribute Name	Tag	Value
Standard Edge Enhancement Sequence	(0029,xx00)	(if applied) contains two items
>Private Creator	(0029,00xx)	CARDIO-D.R. 1.0
>Convolution Kernel Size	(0029,xx01)	<value Pair x-,y-size>
>Convolution kernel Coefficients	(0029xx02)	<row by row, as specified by size>
>Edge Enhancement Gain	(0029,xx03)	(in %)
>Private Creator	(0029,00xx)	SIEMENS MEDCOM HEADER
<i>Attributes according to "A.2.3 MEDCOM Header Module"</i>		
Requesting Physician	(0032,1032)	From RIS
Requesting Service	(0032,1033)	From RIS
Requested Procedure Description	(0032,1060)	From RIS
Requested Procedure Code Sequence	(0032,1064)	From RIS
>Code Value	(0008,0100)	From RIS
>Coding Scheme Designator	(0008,0102)	From RIS
>Coding Scheme Version	(0008,0103)	From RIS
>Code Meaning	(0008,0104)	From RIS
Requested Contrast Agent	(0032,1070)	From RIS
Study Comments	(0032,4000)	"Exam Comment" input
Special Needs	(0038,0050)	From RIS
Patient State	(0038,0500)	From RIS
Performed Procedure Step Start Date	(0040,0244)	supplied, even if MPPS SOP class is not supported
Performed Procedure Step Start Time	(0040,0245)	supplied, even if MPPS SOP class is not supported
Performed Procedure Step ID	(0040,0253)	supplied, even if MPPS SOP class is not supported, "XAyyyyymmddhhmmss" is set with 1st Image acquired
Request Attributes Sequence	(0040,0275)	only if SOP is done under Scheduled Procedure Step, else Sequence is not encoded
>Scheduled Procedure Step Description	(0040,0007)	From RIS
>Scheduled Procedure Step ID	(0040,0009)	From RIS
>Requested Procedure ID	(0040,1001)	From RIS or "Request ID" input
Confidentiality Constraint on Patient Data Description	(0040,3001)	From RIS
Curve Dimensions	(5000,0005)	2
Number of Points	(5000,0010)	<number of data points>
Type of Data	(5000,0020)	EKG
Axis Units	(5000,0030)	DPPSNONE (DPPS = data points per second)
Data Value Presentation	(5000,0103)	0000h
Curve Data Descriptor	(5000,0110)	0\1
Coordinate Start Value	(5000,0112)	0
Coordinate Step Value	(5000,0114)	<sampling rate>
Curve Data	(5000,3000)	
Overlay Rows	(60xx,0010)	
Overlay Columns	(60xx,0011)	
Number of Frames in Overlay	(60xx,0015)	<number>
Overlay Description	(60xx,0022)	
Overlay Type	(60xx,0040)	G
Overlay Origin	(60xx,0050)	1\1
Image Frame Origin	(60xx,0051)	<1-based number>
Overlay Bits Allocated	(60xx,0100)	1 or 16 (if uncompressed)
Overlay Bit Position	(60xx,0102)	12 or 0 (if Overlay encoded in [60xx,3000])
Overlay Data	(60xx,3000)	<contains Overlay> (not with uncompressed)
Pixel Data	(7FE0,0010)	

Table 91 Overview of supplied attributes- X-Ray-Angiographic images (Original, Derived)

**A.5 Private Non-Image IOD**

The AXIOM Artis VB22 will create numerical data that cannot be correlated to an individual image instance and therefore need to be stored in separate instance(s). This is necessary to correlate the information in the right level of the DICOM data model hierarchy. Since there is no fitting DICOM SOP Class definition, SIEMENS has created a private “Non-Image IOD” to contain numerical data heaps to be managed within a DICOM structure. Please see previous chapters of the Appendix for IOD definition and the following tables for detailed encoding of the different “Non-Image SOP Class Instances”.

Attribute Name	Tag	Value
Specific Character Set	(0008,0005)	from Configuration
Image Type	(0008,0008)	ORIGINAL\PRIMARY\SINGLE PLANE\STUDY REPORT
SOP Class UID	(0008,0016)	1.3.12.2.1107.5.9.1
SOP Instance UID	(0008,0018)	
Study Date	(0008,0020)	<yyyymmdd>
Series Date	(0008,0021)	<yyyymmdd>
Study Time	(0008,0030)	<hhmmss>
Series Time	(0008,0031)	<hhmmss>
Accession Number	(0008,0050)	RIS or “Accession Number” input
Modality	(0008,0060)	XA
Manufacturer	(0008,0070)	SIEMENS
Institution Name	(0008,0080)	
Referring Physician’s Name	(0008,0090)	RIS or input
Station Name	(0008,1010)	from Configuration
Study Description	(0008,1030)	“Study” input
Series Description	(0008,103E)	STUDY REPORT
Performing Physician’s Name	(0008,1050)	input via “Correct”
Manufacturer’s Model Name	(0008,1090)	from Original
Patient’s Name	(0010,0010)	from Original
Patient ID	(0010,0020)	from Original
Patient’s Birth Date	(0010,0030)	from Original
Patient’s Sex	(0010,0040)	from Original
Patient’s Age	(0010,1010)	from Original
Device Serial Number	(0018,1000)	from Original
Software Version	(0018,1020)	from Original + “<WS version>”
Study Instance UID	(0020,000D)	from Original
Series Instance UID	(0020,000E)	
Study ID	(0020,0010)	from Original
Series Number	(0020,0011)	
Image Number	(0020,0013)	
Patient Comments	(0020,4000)	“Exam Comment” input
Private Creator	(7FE1,00xx)	SIEMENS CSA NON-IMAGE
Non-Image Data	(7FE1,xx10)	<Study Report data> (encoded as 8-Bit ASCII data, with <LF> as line separator)

Table 92 Data Dictionary of private IOD Definition –Study-Report

**A.6 Quant Report Images**

The AXIOM Artis system will create result images from performing Quantitative Analysis Functions. To ensure image interchange, the resulting reports are converted to XA multiframe with dedicated header data.

Attribute Name	Tag	Value
Specific Character Set	(0008,0005)	From Configuration
Image Type	(0008,0008)	DERIVED\SECONDARY\<3rd to nth value from Original>\QUANT
SOP Class UID	(0008,0016)	1.2.840.10008.5.1.4.1.1.12.1
SOP Instance UID	(0008,0018)	
Study Date	(0008,0020)	<yyyymmdd>
Series Date	(0008,0021)	<yyyymmdd>(Quant Series)
Acquisition Date	(0008,0022)	Date of Original Acquisition
Content Date	(0008,0023)	<yyyymmdd> (Date of Creation)
Study Time	(0008,0030)	<hhmmss>
Series Time	(0008,0031)	<hhmmss>
Acquisition Time	(0008,0032)	Time of Original Acquisition
Content Time	(0008,0033)	<hhmmss> (Time of Creation)
Accession Number	(0008,0050)	From Original
Modality	(0008,0060)	XA
Manufacturer	(0008,0070)	Siemens
Institution Name	(0008,0080)	From Original
Referring Physician's Name	(0008,0090)	From Original
Station Name	(0008,1010)	from Configuration (VB22x or later)
Study Description	(0008,1030)	From Original
Series Description	(0008,103E)	Input from Analysis
Performing Physician's Name	(0008,1050)	From Original
Operator's Name	(0008,1070)	From Original
Admitting Diagnosis Description	(0008,1080)	From Original
Manufacturer's Model Name	(0008,1090)	AXIOM-Artis
Referenced Patient Sequence	(0008,1120)	From Original
>Referenced SOP Class UID	(0008,1150)	
>Referenced SOP Instance UID	(0008,1155)	
Start Trim	(0008,2142)	<1 st frame to display>
Stop Trim	(0008,2143)	<last frame to display>
Recomm. Display Frame Rate	(0008,2144)	(in f/s)
Patient's Name	(0010,0010)	From Original
Patient ID	(0010,0020)	From Original
Patient's Birth Date	(0010,0030)	From Original
Patient's Sex	(0010,0040)	From Original
Other Patient IDs	(0010,1000)	From Original
Other Patient Names	(0010,1001)	From Original
Patient's Age	(0010,1010)	From Original
Patient's Size	(0010,1020)	(in meters)
Patient's Weight	(0010,1030)	(in kilograms)
Medical Alerts	(0010,2000)	From Original
Contrast Allergies	(0010,2110)	From Original
Pregnancy Status	(0010,21C0)	From Original
Patient Comment	(0010,4000)	From Original
Contrast/Bolus Agent	(0018,0010)	From Original

Attribute Name	Tag	Value
Cine Rate	(0018,0040)	1
KVP	(0018,0060)	From Original
Device Serial Number	(0018,1000)	<modality serial number>
Software Version	(0018,1020)	
Protocol Name	(0018,1030)	From Original
Contrast Bolus Ingredient	(0018,1048)	From Original
Frame Time	(0018,1063)	1000
Distance Source to Detector	(0018,1110)	From Original
Distance Source to Patient	(0018,1111)	From Original
Exposure Time	(0018,1150)	<duration of x-Ray exposure>(msec)
X-Ray Tube Current	(0018,1151)	From Original
Average Pulse Width	(0018,1154)	From Original
Radiation Setting	(0018,1155)	From Original
Radiation Mode	(0018,115A)	From Original
Image Area Dose Product	(0018,115E)	From Original
Intensifier Size	(0018,1162)	From Original
Imager Pixel Spacing	(0018,1164)	From Original
Focal Spot	(0018,1190)	From Original
Positioner Motion	(0018,1500)	From Original
Positioner Primary Angle	(0018,1510)	From Original
Positioner Secondary Angle	(0018,1511)	From Original
Positioner Primary Angle Increment	(0018,1520)	From Original (Only with DYNAMIC)
Positioner Secondary Angle Increment	(0018,1521)	From Original (Only with DYNAMIC)
Patient Position	(0018,5100)	From Original
Private Creator	(0019,00xx)	SIEMENS SMS-AX VIEW 1.0
<i>Attributes according to "A.2.6 Angio Viewing Module"</i>		
Study Instance UID	(0020,000D)	From Original
Series Instance UID	(0020,000E)	
Study ID	(0020,0010)	From Original
Series Number	(0020,0011)	
Acquisition Number	(0020,0012)	From Original
Instance Number	(0020,0013)	
Patient Orientation	(0020,0020)	From Original
Images in Acquisition	(0020,1002)	
Private Creator	(0021,00xx)	SIEMENS SMS-AX ACQ 1.0
<i>Attributes according to "A.2.7 Angio Acquisition Data Module"</i>		
Private Creator	(0023,00xx)	SIEMENS SMS-AX QUANT 1.0
<i>Attributes according to "A.2.8 Angio Quantitation Module" if image was calibrated</i>		
Private Creator	(0025,00xx)	SIEMENS SMS-AX ORIGINAL IMAGE INFO 1.0
<i>Attributes according to "A.2.9 Original Image Info Module"</i>		
Samples per Pixel	(0028,0002)	1
Photometric Interpretation	(0028,0004)	MONOCHROME2
Number of Frames	(0028,0008)	1 to 4
Frame Increment Pointer	(0028,0009)	(0018,1063)
Rows	(0028,0010)	1024
Columns	(0028,0011)	1024
Bits Allocated	(0028,0100)	16
Bits Stored	(0028,0101)	12
High Bit	(0028,0102)	11
Pixel Representation	(0028,0103)	0
Pixel Intensity Relationship	(0028,0103)	LIN
Window Center	(0028,1050)	2047
Window Width	(0028,1051)	4095

Attribute Name	Tag	Value
Lossy Image Compression	(0028,2110)	From Original
Representative Frame Number	(0028,6010)	1
Study Status ID	(0032,000A)	From Original
Scheduled Study Start Date	(0032,1000)	From Original
Scheduled Study Start Time	(0032,1001)	From Original
Scheduled Study Location	(0032,1020)	From Original
Scheduled Study Location AE Title(s)	(0032,1021)	From Original
Requesting Physician	(0032,1032)	From Original
Requesting Service	(0032,1033)	From Original
Requested Procedure Description	(0032,1060)	From Original
Requested Procedure Code Sequence	(0032,1064)	From Original
>Code Value	(0008,0100)	From Original
>Coding Scheme Designator	(0008,0102)	From Original
>Coding Scheme Version	(0008,0103)	From Original
>Code Meaning	(0008,0104)	From Original
Requested Contrast Agent	(0032,1070)	From Original
Study Comments	(0032,4000)	From Original
Performed Procedure Step Start Date	(0040,0244)	From Original
Performed Procedure Step Start Time	(0040,0245)	From Original
Performed Procedure Step ID	(0040,0253)	From Original
Request Attributes Sequence	(0040,0275)	From Original
>Scheduled Procedure Step Description	(0040,0007)	From Original
>Scheduled Procedure Step ID	(0040,0009)	From Original
>Requested Procedure ID	(0040,1001)	From Original
Confidentiality Constraint on Patient Data Description	(0040,3001)	From Original
Pixel Data	(7FE0,0010)	

Table 93 Overview of supplied attributes- X-Ray-Angiographic image (Quant Report Image)

## A.7 CT/MR Image Converted to XA IOD

The AXIOM Artis system will create reference images from CT or MR images. Those will be encoded as derived XA Standard Extended SOP Class. Please see the following table for a complete overview of supplied Type 1/2/3 Standard and additional Private Attributes:

Attribute Name	Tag	Value
Specific Character Set	(0008,0005)	From Configuration
Image Type	(0008,0008)	See "A.2.10. SOP Common Module-Image Type Extensions"
SOP Class UID	(0008,0016)	1.2.840.10008.5.1.4.1.1.12.1
SOP Instance UID	(0008,0018)	<new UID>
Study Date	(0008,0020)	From Original or changed by CorRea (Drag&Drop)
Series Date	(0008,0021)	<yyyymmdd>
Acquisition Date	(0008,0022)	Date of Original Acquisition if provided by CT
Content Date	(0008,0023)	<yyyymmdd> (Date of Creation)
Study Time	(0008,0030)	From Original or changed by CorRea (Drag&Drop)
Series Time	(0008,0031)	<hhmmss>
Acquisition Time	(0008,0032)	Time of Original Acquisition
Content Time	(0008,0033)	<hhmmss> (Time of Creation)
Accession Number	(0008,0050)	From Original or changed by CorRea (Drag&Drop)
Modality	(0008,0060)	XA
Manufacturer	(0008,0070)	Siemens
Institution Name	(0008,0080)	From Original (Equipment)
Referring Physician's Name	(0008,0090)	From Original or changed by CorRea (Drag&Drop)
Station Name	(0008,1010)	Artis Station Name (VB22x or later)
Study Description	(0008,1030)	From Original or changed by CorRea (Drag&Drop)
Series Description	(0008,103E)	From Original
Institutional Department Name	(0008,1040)	From Original (Equipment)
Performing Physician's Name	(0008,1050)	From Original (series)
Operator's Name	(0008,1070)	From Original (series)
Admitting Diagnosis Description	(0008,1080)	From Original or changed by CorRea (Drag&Drop)
Manufacturer's Model Name	(0008,1090)	AXIOM-Artis
Source Image Sequence	(0008,2112)	Reference to original CT image
>Referenced SOP Class UID	(0008,1150)	1.2.840.10008.5.1.4.1.1.2 (CT image)
>Referenced SOP Instance UID	(0008,1155)	From Original (0008,0018)
Patient's Name	(0010,0010)	From Original or changed by CorRea (Drag&Drop)
Patient ID	(0010,0020)	From Original or changed by CorRea (Drag&Drop)
Patient's Birth Date	(0010,0030)	From Original or changed by CorRea (Drag&Drop)
Patient's Sex	(0010,0040)	From Original or changed by CorRea (Drag&Drop)
Patient's Age	(0010,1010)	From Original or changed by CorRea (Drag&Drop)
Patient's Size	(0010,1020)	From Original or changed by CorRea (Drag&Drop)
Patient's Weight	(0010,1030)	From Original or changed by CorRea (Drag&Drop)
Medical Alerts	(0010,2000)	From Original
Contrast Allergies	(0010,2110)	From Original
Pregnancy Status	(0010,21C0)	From Original
Patient Comment	(0010,4000)	From Original or changed by CorRea (Drag&Drop)
Contrast/Bolus Agent	(0018,0010)	From Original (Contrast/Bolus)
KVP	(0018,0060)	From Original (image)
Device Serial Number	(0018,1000)	<Artis serial number>
Software Version	(0018,1020)	<Artis software version>
Protocol Name	(0018,1030)	From Original (Series Description)

Attribute Name	Tag	Value
Contrast Bolus Ingredient	(0018,1048)	From Original (Contrast/Bolus)
Estimated Radiographic Magnification Factor	(0018,1114)	1.0
Exposure Time	(0018,1150)	From Original (CT image)
X-Ray Tube Current	(0018,1151)	From Original (CT image)
Radiation Setting	(0018,1155)	GR
Image Area Dose Product	(0018,115E)	<zero length>
Imager Pixel Spacing	(0018,1164)	Values taken from original "(0028,0030) Pixel Spacing" (Image Plane)
Positioner Primary Angle	(0018,1510)	<zero length>
Positioner Secondary Angle	(0018,1511)	<zero length>
Private Creator	(0019,00xx)	SIEMENS SMS-AX VIEW 1.0
<i>Attributes according to "A.2.6 Angio Viewing Module"</i>		
Study Instance UID	(0020,000D)	From Original or changed by CorRea (Drag&Drop)
Series Instance UID	(0020,000E)	<new UID>
Study ID	(0020,0010)	From Original or changed by CorRea (Drag&Drop)
Series Number	(0020,0011)	"1000-based counter"
Acquisition Number	(0020,0012)	From Original (image)
Instance Number	(0020,0013)	"2000-based" counter
Patient Orientation	(0020,0020)	From Original (series)
Images in Acquisition	(0020,1002)	
Image Comments	(0020,4000)	From Original (image)
Private Creator	(0021,00xx)	SIEMENS SMS-AX ACQ 1.0
<i>Attributes according to "A.2.7 Angio Acquisition Data Module"</i>		
Samples per Pixel	(0028,0002)	1
Photometric Interpretation	(0028,0004)	MONOCHROME2
Rows	(0028,0010)	From Original (image) <i>only 512 supported</i>
Columns	(0028,0011)	From Original (image) <i>only 512 supported</i>
Bits Allocated	(0028,0100)	16
Bits Stored	(0028,0101)	12 (converted)
High Bit	(0028,0102)	11 (converted)
Pixel Representation	(0028,0103)	0 (converted to unsigned)
Pixel Intensity Relationship	(0028,0103)	LIN or DISP
Window Center	(0028,1050)	Calculated from Original Window Center and Rescale intercept (VOI LUT, MOD LUT)
Window Width	(0028,1051)	From Original (VOI LUT)
Lossy Image Compression	(0028,2110)	From Original (image)
Study Status ID	(0032,000A)	From Original
Scheduled Study Start Date	(0032,1000)	From Original
Scheduled Study Start Time	(0032,1001)	From Original
Scheduled Study Location	(0032,1020)	From Original
Scheduled Study Location AE Title(s)	(0032,1021)	From Original
Requesting Physician	(0032,1032)	From Original
Requesting Service	(0032,1033)	From Original
Requested Procedure Description	(0032,1060)	From Original
Requested Contrast Agent	(0032,1070)	From Original
Study Comments	(0032,4000)	From Original or changed by CorRea (Drag&Drop)
Performed Procedure Step Start Date	(0040,0244)	From Original (series), if existent
Performed Procedure Step Start Time	(0040,0245)	From Original (series), if existent
Performed Procedure Step ID	(0040,0253)	From Original (series), if existent
Request Attributes Sequence	(0040,0275)	From Original (series), if existent
>item contents as provided		As set from Original (series)
Overlay Rows	(60xx,0010)	Same as (0028,0010)
Overlay Columns	(60xx,0011)	Same as (0028,0011)
Overlay Description	(60xx,0022)	from Original (Overlay)

Attribute Name	Tag	Value
Overlay Type	(60xx,0040)	from Original (Overlay)
Overlay Origin	(60xx,0050)	1\from Original (Overlay)
Overlay Bits Allocated	(60xx,0100)	from Original (Overlay)
Overlay Bit Position	(60xx,0102)	from Original (Overlay)
Overlay Data	[60xx,3000]	from Original (Overlay)
Pixel Data	(7FE0,0010)	Possibly converted from original pixel data

Table 94 Overview of supplied attributes- XA image (Derived) from CT image

Attribute Name	Tag	Value
Specific Character Set	(0008,0005)	From Configuration
Image Type	(0008,0008)	See "A.2.10. SOP Common Module-Image Type Extensions"
SOP Class UID	(0008,0016)	1.2.840.10008.5.1.4.1.1.12.1
SOP Instance UID	(0008,0018)	<new UID>
Study Date	(0008,0020)	From Original or changed by CorRea (Drag&Drop)
Series Date	(0008,0021)	<yyyymmdd>
Acquisition Date	(0008,0022)	Date of Original Acquisition if provided by MR
Content Date	(0008,0023)	<yyyymmdd> (Date of Creation)
Study Time	(0008,0030)	From Original or changed by CorRea (Drag&Drop)
Series Time	(0008,0031)	<hhmmss>
Acquisition Time	(0008,0032)	Time of Original Acquisition if provided by MR
Content Time	(0008,0033)	<hhmmss> (Time of Creation)
Accession Number	(0008,0050)	From Original or changed by CorRea (Drag&Drop)
Modality	(0008,0060)	XA
Manufacturer	(0008,0070)	Siemens
Institution Name	(0008,0080)	From Original (Equipment)
Referring Physician's Name	(0008,0090)	From Original or changed by CorRea (Drag&Drop)
Station Name	(0008,1010)	Artis Station Name (VB22x or later)
Study Description	(0008,1030)	From Original or changed by CorRea (Drag&Drop)
Series Description	(0008,103E)	From Original
Institutional Department Name	(0008,1040)	From Original (Equipment)
Performing Physician's Name	(0008,1050)	From Original (series)
Operator's Name	(0008,1070)	From Original (series)
Admitting Diagnosis Description	(0008,1080)	From Original or changed by CorRea (Drag&Drop)
Manufacturer's Model Name	(0008,1090)	AXIOM-Artis
Source Image Sequence	(0008,2112)	Reference to original MR image
>Referenced SOP Class UID	(0008,1150)	1.2.840.10008.5.1.4.1.1.4 (MR image)
>Referenced SOP Instance UID	(0008,1155)	From Original (0008,0018)
Patient's Name	(0010,0010)	From Original or changed by CorRea (Drag&Drop)
Patient ID	(0010,0020)	From Original or changed by CorRea (Drag&Drop)
Patient's Birth Date	(0010,0030)	From Original or changed by CorRea (Drag&Drop)
Patient's Sex	(0010,0040)	From Original or changed by CorRea (Drag&Drop)
Patient's Age	(0010,1010)	From Original or changed by CorRea (Drag&Drop)
Patient's Size	(0010,1020)	From Original or changed by CorRea (Drag&Drop)
Patient's Weight	(0010,1030)	From Original or changed by CorRea (Drag&Drop)
Medical Alerts	(0010,2000)	From Original
Contrast Allergies	(0010,2110)	From Original
Pregnancy Status	(0010,21C0)	From Original
Patient Comment	(0010,4000)	From Original or changed by CorRea (Drag&Drop)
Contrast/Bolus Agent	(0018,0010)	From Original (Contrast/Bolus)
KVP	(0018,0060)	<zero length>
Device Serial Number	(0018,1000)	<Artis serial number>

Attribute Name	Tag	Value
Software Version	(0018,1020)	<Artis software version>
Protocol Name	(0018,1030)	From Original (Series Description)
Contrast Bolus Ingredient	(0018,1048)	From Original (Contrast/Bolus)
Estimated Radiographic Magnification Factor	(0018,1114)	1.0
Radiation Setting	(0018,1155)	SC (even if created w/o radiation!)
Image Area Dose Product	(0018,115E)	<zero length>
Imager Pixel Spacing	(0018,1164)	Values taken from original "(0028,0030) Pixel Spacing" (Image Plane)
Positioner Primary Angle	(0018,1510)	<zero length>
Positioner Secondary Angle	(0018,1511)	<zero length>
Private Creator	(0019,00xx)	SIEMENS SMS-AX VIEW 1.0
<i>Attributes according to "A.2.6 Angio Viewing Module"</i>		
Study Instance UID	(0020,000D)	From Original or changed by CorRea (Drag&Drop)
Series Instance UID	(0020,000E)	<new UID>
Study ID	(0020,0010)	From Original or changed by CorRea (Drag&Drop)
Series Number	(0020,0011)	"1000-based counter"
Acquisition Number	(0020,0012)	From Original (image)
Instance Number	(0020,0013)	"2000-based" counter
Patient Orientation	(0020,0020)	From Original (series)
Images in Acquisition	(0020,1002)	
Image Comments	(0020,4000)	From Original (image)
Private Creator	(0021,00xx)	SIEMENS SMS-AX ACQ 1.0
<i>Attributes according to "A.2.7 Angio Acquisition Data Module"</i>		
Samples per Pixel	(0028,0002)	1
Photometric Interpretation	(0028,0004)	MONOCHROME2
Rows	(0028,0010)	From Original (image) <i>only 512 supported</i>
Columns	(0028,0011)	From Original (image) <i>only 512 supported</i>
Bits Allocated	(0028,0100)	16
Bits Stored	(0028,0101)	12 (converted)
High Bit	(0028,0102)	11 (converted)
Pixel Representation	(0028,0103)	0 (converted to unsigned)
Pixel Intensity Relationship	(0028,0103)	LIN or DISP
Window Center	(0028,1050)	Calculated from Original Window Center and Rescale intercept (VOI LUT, MOD LUT)
Window Width	(0028,1051)	From Original (VOI LUT)
Lossy Image Compression	(0028,2110)	From Original (image)
Study Status ID	(0032,000A)	From Original
Scheduled Study Start Date	(0032,1000)	From Original
Scheduled Study Start Time	(0032,1001)	From Original
Scheduled Study Location	(0032,1020)	From Original
Scheduled Study Location AE Title(s)	(0032,1021)	From Original
Requesting Physician	(0032,1032)	From Original
Requesting Service	(0032,1033)	From Original
Requested Procedure Description	(0032,1060)	From Original
Requested Contrast Agent	(0032,1070)	From Original
Study Comments	(0032,4000)	From Original or changed by CorRea (Drag&Drop)
Performed Procedure Step Start Date	(0040,0244)	From Original (series), if existent
Performed Procedure Step Start Time	(0040,0245)	From Original (series), if existent
Performed Procedure Step ID	(0040,0253)	From Original (series), if existent
Request Attributes Sequence	(0040,0275)	From Original (series), if existent
>item contents as provided		As set from Original (series)
Overlay Rows	(60xx,0010)	Same as (0028,0010)
Overlay Columns	(60xx,0011)	Same as (0028,0011)
Overlay Description	(60xx,0022)	from Original (Overlay)

Attribute Name	Tag	Value
Overlay Type	(60xx,0040)	from Original (Overlay)
Overlay Origin	(60xx,0050)	1\from Original (Overlay)
Overlay Bits Allocated	(60xx,0100)	from Original (Overlay)
Overlay Bit Position	(60xx,0102)	from Original (Overlay)
Overlay Data	[60xx,3000]	from Original (Overlay)
Pixel Data	(7FE0,0010)	Possibly converted from original pixel data

Table 95 Overview of supplied attributes- XA image (Derived) from MR image

**A.8 Sorting Order AXIOM Artis VB22**

This section discusses the sorting algorithms for Artis within the patient browser and directory overview.

**A.8.1 Identification of Images**

Original acquired images are identified by the following attribute contents:

Attribute Name	Tag	Value
Image Type	(0008,0008)	ORIGINAL\PRIMARY\SINGLE PLANE\SINGLE A ORIGINAL\PRIMARY\SINGLE PLANE\SINGLE B ORIGINAL\PRIMARY\BIPLANE A ORIGINAL\PRIMARY\BIPLANE B ORIGINAL\PRIMARY\SINGLE PLANE/PLANE A/PERI/MASK/n ORIGINAL\PRIMARY\SINGLE PLANE/PLANE A/PERI/FILL/n ORIGINAL\PRIMARY\SINGLE PLANE/PLANE A/DYNA/MASK ORIGINAL\PRIMARY\SINGLE PLANE/PLANE A/DYNA/INJECTION ORIGINAL\PRIMARY\SINGLE PLANE/PLANE A/DYNA/FILL ORIGINAL\PRIMARY\SINGLE PLANE/PLANE A/DYNA/WASHOUT DERIVED\PRIMARY\SINGLE PLANE\SINGLE A\STORE FLUORO DERIVED\PRIMARY\SINGLE PLANE\SINGLE B\STORE FLUORO DERIVED\PRIMARY\BIPLANE A\STORE FLUORO DERIVED\PRIMARY\BIPLANE B\STORE FLUORO
Series Time	(0008,0031)	Same as Acquisition Time
Acquisition Time	(0008,0032)	Time the acquisition of this image was performed
Content Time	(0008,0033)	Same as Acquisition Time (rule for acquired images)
Series Number	(0020,0011)	Same as Acquisition Number
Acquisition Number	(0020,0012)	Counts number of acquisitions. All images created during performance of this acquisition have the same number.
Instance Number	(0020,0013)	"1-based" counter for images. Indicates the creation order within the acquisition.

Table 96 Identifications of images

Store Monitor images, derived from original images or Fluoro LIH, are identified by the following attribute contents:

Attribute Name	Tag	Value
Image Type	(0008,0008)	DERIVED\SECONDARY\SINGLE PLANE\SINGLE A\STORE MONITOR DERIVED\SECONDARY\SINGLE PLANE\SINGLE B\STORE MONITOR
Series Time	(0008,0031)	Same as Acquisition Time. Store Monitor is in same series.
Acquisition Time	(0008,0032)	Time the acquisition of the original image was performed
Content Time	(0008,0033)	Time this image was created (Store Monitor was performed)
Series Number	(0020,0011)	Same Number as Acquisition Number. (Reference to original image)
Acquisition Number	(0020,0012)	Counts number of acquisitions. Refers to the acquisition number of the original image where this image was derived from.
Instance Number	(0020,0013)	"300-based" counter for images. Indicates the creation order of Store Monitor Reference images within this series

Table 97 Identifications of Store Monitor images

Store Reference images, derived from original images or Fluoro LIH, are identified by the following attribute contents:

Attribute Name	Tag	Value
Image Type	(0008,0008)	DERIVED\SECONDARY\SINGLE PLANE\SINGLE A\REFIMAGE DERIVED\SECONDARY\SINGLE PLANE\SINGLE B\REFIMAGE
Series Time	(0008,0031)	Same as Acquisition Time. Store Reference image is in same series.
Acquisition Time	(0008,0032)	Time the acquisition of the original image was performed
Content Time	(0008,0033)	Time this image was created (Store Reference image was performed)

Attribute Name	Tag	Value
Series Number	(0020,0011)	Same Number as Acquisition Number. (Reference to original Image)
Acquisition Number	(0020,0012)	Counts number of acquisitions. Refers to the acquisition number of the original image where this image was derived from.
Instance Number	(0020,0013)	"100-based" counter for images. Indicates the creation order of Store Reference images within this series

Table 98 Identifications of Reference images

**Quant Report images**, derived from original images or Fluoro LIH, are identified by the following attribute contents:

Attribute Name	Tag	Value
Image Type	(0008,0008)	DERIVED\SECONDARY\SINGLE PLANE\SINGLE A\QUANT DERIVED\SECONDARY\SINGLE PLANE\SINGLE B\QUANT
Series Time	(0008,0031)	Time this Quant image was created (Quant was performed)
Acquisition Time	(0008,0032)	Time the acquisition of the original image was performed
Content Time	(0008,0033)	Time this Quant image was created (Quant was performed)
Series Number	(0020,0011)	Same Number as Acquisition Number. (Reference to original Image)
Acquisition Number	(0020,0012)	Counts number of acquisitions. Refers to the acquisition number of the original image where this image was derived from.
Instance Number	(0020,0013)	"1-based" counter for images. Quant Reports are stored in new series.

Table 99 Identifications of Quant report images

**EXAM PROTOCOL non-image**, created once per study, is identified by the following attribute contents:

Attribute Name	Tag	Value
Image Type	(0008,0008)	ORIGINAL\PRIMARY\SINGLE PLANE\EXAM PROTOCOL
SOP Class UID	(0008,0016)	1.3.12.2.1107.5.9.1
Series Time	(0008,0031)	Study Report is allocated with Patient Registration.
Acquisition Time	(0008,0032)	Not set
Content Time	(0008,0033)	Not set
Series Number	(0020,0011)	Fixed value of "999"
Acquisition Number	(0020,0012)	Not set
Instance Number	(0020,0013)	Not set

Table 100 Identifications of Exam Protocol non-images

### A.8.2 The Sorting Algorithms of the Artis Viewer

AXIOM Artis has implemented sorting algorithms to display DICOM objects in the directory overview in a specific order. Sorting/Grouping in the Viewer Directory Overview occurs according the following rules:

1. Sort by Series Number
2. If Series Number matches: Group on Series Number, Sort by Content Number
3. If Series Number and Content Number each match: Group on Series Number, Sort by Content Time

In the case, that the user has selected "Scenes + Ref Images" or "Scenes + Store Monitor", the reference images or the store monitor images follow directly the image they had been derived from.

**Example 1:**

Patient "Test 1" with one Study, three Series with one acquired image, three Store Monitor Images and one Reference Image in each Series. "Scenes" is selected under the "Dir Overview" button => only the acquired images are displayed.

**Patient "Test 1"**

Study 1 Series 1 Image 1	Study 1 Series 2 Image 1	Study 1 Series 3 Image 1	

	Acquired Image
	Store Monitor Image
	Store Reference Image

Figure 11 Image ordering – simple case

**Example 2:**

Patient "Test 2" with one Study, three Series with one acquired image, three Store Monitor Images and one Reference Image in each Series. "Scenes+Ref Images" is selected under the "Dir Overview" button => the acquired images and the corresponding reference images are displayed.

**Patient "Test 2"**

Study 1 Series 1 Image 1	Study 1 Series 1 Image 100	Study 1 Series 2 Image 1	Study 1 Series 2 Image 100
Study 1 Series 3 Image 1	Study 1 Series 3 Image 100		

	Acquired Image
	Store Monitor Image
	Store Reference Image

Figure 12 Image ordering – with reference images

**Example 3:**

Patient "Test 3" with one Study, three Series with one acquired image, three Store Monitor Images and one Reference Image in each Series. "Scenes+Store Monitor" is selected under the "Dir Overview" button => the acquired images and the corresponding store monitor images are displayed.

**Patient "Test 31"**

Study 1 Series 1 Image 1	Study 1 Series 1 Image 300	Study 1 Series 1 Image 301	Study 1 Series 1 Image 302
Study 1 Series 2 Image 1	Study 1 Series 2 Image 300	Study 1 Series 2 Image 301	Study 1 Series 2 Image 302
Study 1 Series 3 Image 1	Study 1 Series 3 Image 300	Study 1 Series 3 Image 301	Study 1 Series 3 Image 302

	Acquired Image
	Store Monitor Image
	Store Reference Image

Figure 13 Image ordering – with Store Monitor images

**Example 4:**

For Scene #2 of Patient "Test 3" now a Quant Report is performed. According to Example 3, the Overview now sorts as follows:

**Patient "Test 1"**

Study 1 Series 1 Image 1	Study 1 Series 1 Image 300	Study 1 Series 1 Image 301	Study 1 Series 1 Image 302
Study 1 Series 2 Image 1	Study 1 Series 2(Quant) Image 1(Quant)	Study 1 Series 2 Image 300	Study 1 Series 2 Image 301
Study 1 Series 2 Image 302	Study 1 Series 3 Image 300	Study 1 Series 3 Image 301	Study 1 Series 3 Image 302
Study 1 Series 3 Image 1			

	Acquired Image
	Store Monitor Image
	Store Reference Image
	Quant Report Image

Figure 14 Image ordering – with Store Monitor and Quant images

**A.8.3 The Sorting Algorithms of Artis Browser**

Besides the default sorting criteria, Artis supports the following sorting algorithms for the patient browser.

The default syngo sorting settings are as follows

- Artis displays images - within a Series - with the order they had been acquired
- Artis displays Series - within a Study - with the order they had been acquired
- Artis displays Studies - within a Patient - with the order they had been acquired

Therefore the Quant Report Series will not necessarily be displayed adjacent to the original scene, if created later at the end of all scenes.

**A.9 DICOM Print SCU – detailed status displays**

The following tables document the behavior of the AXIOM Artis VB22 DICOM Print AE in response to messages received for the printer SOP class and the print job SOP class.

Definitions of camera symbols:

- Idle: Camera is installed and ready; idle icon is displayed.
- Interact: The user has to react in near future, but not immediately.  
Example: A camera was low in 8x10 clear sheets: LOW 8x10 CLR was sent by n-event-report.
- Queue Stopped: The user has to react immediately. Either the camera needs immediate interaction or a job has been aborted.  
Example: A camera is out of 8x10 clear sheets, or camera is down, or a film job is aborted.

Note: different camera symbols are displayed according to the Printer Status Info.

The Printer Status (Success, Warning, Failure) is not evaluated, since the Printer Status Info is much more detailed and allows a more appropriate reaction of the system.

**A.9.1 Common Status Information**

*“Printer Status Infos within Printer SOP Class/Execution Status Infos within Print Job SOP class”*

Printer Status Info/ Execution Status Info	Description	Message string visible in 'Status Bar'	Other action for UI/ 'camera symbol'
NORMAL	Camera is ready	Camera is ready	<None>/idle
BAD RECEIVE MGZ	There is a problem with the film receive magazine. Films from the printer cannot be transported into the magazine.	Problem with receive magazine.	<None>/interact
BAD SUPPLY MGZ	There is a problem with the film supply magazine. Films from this magazine cannot be transported into the printer.	Problem with supply magazine.	<None>/interact
CALIBRATING	Printer is performing self calibration, it is expected to be available for normal operation shortly.	Self calibration. Please wait.	<None>/idle
CALIBRATION ERR	An error in the printer calibration has	Problem in calibration.	<None>/interact

Printer Status Info/ Execution Status Info	Description	Message string visible in 'Status Bar'	Other action for UI/ 'camera symbol'
	been detected, quality of processed films may not be optimal.	Film quality may not be optimal.	
CHECK CHEMISTRY	A problem with the processor chemicals has been detected, quality of processed films may not be optimal.	Problem with chemistry. Film quality may not be optimal.	<None>/interact
CHECK SORTER	There is an error in the film sorter	Error in film sorter.	<None>/interact
CHEMICALS EMPTY	There are no processing chemicals in the processor, films will not be printed and processed until the processor is back to normal.	Camera chemistry empty. Please check.	<None>/interact
CHEMICALS LOW	The chemical level in the processor is low, if not corrected, it will probably shut down soon.	Camera chemistry low. Please check.	<None>/interact
COVER OPEN	One or more printer or processor covers, drawers, doors are open.	Camera cover, drawer or door open.	<None>/interact
ELEC CONFIG ERR	Printer configured improperly for this job.	Camera configured improperly for this job. Queue stopped.	<b>Queue for this camera will be STOPPED/ Queue stopped</b>
ELEC DOWN	Printer is not operating due to some unspecified electrical hardware problem.	Camera electrical hardware Problem.	<None>/interact
ELEC SW ERROR	Printer not operating for some unspecified software error.	Camera software problem. Queue stopped.	<b>Queue for this camera will be STOPPED/ Queue stopped</b>
EMPTY 8x10	The 8x10 inch film supply magazine is empty.	8x10 film supply empty.	<None>/interact
EMPTY 8x10 BLUE	The 8x10 inch blue film supply magazine is empty.	8x10 blue film supply empty.	<None>/interact
EMPTY 8x10 CLR	The 8x10 inch clear film supply magazine is empty.	8x10 clear film supply empty.	<None>/interact
EMPTY 8x10 PAPR	The 8x10 inch paper supply magazine is empty.	8x10 paper supply empty.	<None>/interact
EMPTY 10x12	The 10x12 inch film supply magazine is empty.	10x12 film supply empty.	<None>/interact
EMPTY 10x12 BLUE	The 10x12 inch blue film supply magazine is empty.	10x12 blue film supply empty.	<None>/interact
EMPTY 10x12 CLR	The 10x12 inch clear film supply magazine is empty.	10x12 clear film supply empty.	<None>/interact
EMPTY 10x12 PAPR	The 10x12 inch paper supply magazine is empty.	10x12 paper supply empty.	<None>/interact
EMPTY 10x14	The 10x14 inch film supply magazine is empty.	10x14 film supply empty.	<None>/interact
EMPTY 10x14 BLUE	The 10x14 inch blue film supply magazine is empty.	10x14 blue film supply empty.	<None>/interact
EMPTY 10x14 CLR	The 10x14 inch clear film supply magazine is empty.	10x14 clear film supply empty.	<None>/interact
EMPTY 10x14 PAPR	The 10x14 inch paper supply magazine is empty.	10x14 paper supply empty.	<None>/interact
EMPTY 11x14	The 11x14 inch film supply magazine is empty.	11x14 film supply empty.	<None>/interact
EMPTY 11x14 BLUE	The 11x14 inch blue film supply magazine is empty.	11x14 blue film supply empty.	<None>/interact
EMPTY 11x14 CLR	The 11x14 inch clear film supply magazine is empty.	11x14 clear film supply empty.	<None>/interact
EMPTY 11x14 PAPR	The 11x14 inch paper supply magazine is empty.	11x14 paper supply empty.	<None>/interact
EMPTY 14x14	The 14x14 inch film supply magazine is empty.	14x14 film supply empty.	<None>/interact
EMPTY 14x14 BLUE	The 14x14 inch blue film supply magazine is empty.	14x14 blue film supply empty.	<None>/interact
EMPTY 14x14 CLR	The 14x14 inch clear film supply magazine is empty.	14x14 clear film supply empty.	<None>/interact
EMPTY 14x14 PAPR	The 14x14 inch paper supply magazine is empty.	14x14 paper supply empty.	<None>/interact
EMPTY 14x17	The 14x17 inch film supply magazine is empty.	14x17 film supply empty.	<None>/interact
EMPTY 14x17 BLUE	The 14x17 inch blue film supply magazine is empty.	14x17 blue film supply empty.	<None>/interact

Printer Status Info/ Execution Status Info	Description	Message string visible in 'Status Bar'	Other action for UI/ 'camera symbol'
EMPTY 14x17 CLR	The 14x17 inch clear film supply magazine is empty.	14x17 clear film supply empty.	<None>/interact
EMPTY 14x17 PAPR	The 14x17 inch paper supply magazine is empty.	14x17 paper supply empty.	<None>/interact
EMPTY 24x24	The 24x24 inch film supply magazine is empty.	24x24 film supply empty.	<None>/interact
EMPTY 24x24 BLUE	The 24x24 inch blue film supply magazine is empty.	24x24 blue film supply empty.	<None>/interact
EMPTY 24x24 CLR	The 24x24 inch clear film supply magazine is empty.	24x24 clear film supply empty.	<None>/interact
EMPTY 24x24 PAPR	The 24x24 inch paper supply magazine is empty.	24x24 paper supply empty	<None>/interact
EMPTY 24x30	The 24x30 inch film supply magazine is empty.	24x30 film supply empty.	<None>/interact
EMPTY 24x30 BLUE	The 24x30 inch blue film supply magazine is empty.	24x30 blue film supply empty.	<None>/interact
EMPTY 24x30 CLR	The 24x30 inch clear film supply magazine is empty.	24x30 clear film supply empty.	<None>/interact
EMPTY 24x30 PAPR	The 24x30 inch paper supply magazine is empty.	24x30 paper supply empty.	<None>/interact
EMPTY A4 PAPR	The A4 paper supply magazine is empty.	A4 paper supply empty	<None>/interact
EMPTY A4 TRANS	The A4 transparency supply magazine is empty.	A4 transparency supply empty.	<None>/interact
EXPOSURE FAILURE	The exposure device has failed due to some unspecified reason.	Exposure device has failed.	<None>/interact
FILM JAM	A film transport error has occurred and a film is jammed in the printer or processor.	Film jam.	<None>/interact
FILM TRANSP ERR	There is a malfunction with the film transport, there may or may not be a film jam.	Film transport problem.	<None>/interact
FINISHER EMPTY	The finisher is empty.	Finisher is empty.	<None>/interact
FINISHER ERROR	The finisher is not operating due to some unspecified reason	Finisher problem.	<None>/interact
FINISHER LOW	The finisher is low on supplies.	Finisher low.	<None>/interact
LOW 8x10	The 8x10 inch film supply magazine is low.	8x10 film supply low.	<None>/interact
LOW 8x10 BLUE	The 8x10 inch blue film supply magazine is low.	8x10 blue film supply low.	<None>/interact
LOW 8x10 CLR	The 8x10 inch clear film supply magazine is low.	8x10 clear film supply low.	<None>/interact
LOW 8x10 PAPR	The 8x10 inch paper supply magazine is low.	8x10 paper supply low.	<None>/interact
LOW 10x12	The 10x12 inch film supply magazine is low.	10x12 film supply low.	<None>/interact
LOW 10x12 BLUE	The 10x12 inch blue film supply magazine is low.	10x12 blue film supply low.	<None>/interact
LOW 10x12 CLR	The 10x12 inch clear film supply magazine is low.	10x12 clear film supply low.	<None>/interact
LOW 10x12 PAPR	The 10x12 inch paper supply magazine is low.	10x12 paper supply low.	<None>/interact
LOW 10x14	The 10x14 inch film supply magazine is low.	10x14 film supply low.	<None>/interact
LOW 10x14 BLUE	The 10x14 inch blue film supply magazine is low.	10x14 blue film supply low.	<None>/interact
LOW 10x14 CLR	The 10x14 inch clear film supply magazine is low.	10x14 clear film supply low.	<None>/interact
LOW 10x14 PAPR	The 10x14 inch paper supply magazine is low.	10x14 paper supply low.	<None>/interact
LOW 11x14	The 11x14 inch film supply magazine is low.	11x14 film supply low.	<None>/interact
LOW 11x14 BLUE	The 11x14 inch blue film supply magazine is low.	11x14 blue film supply low.	<None>/interact
LOW 11x14 CLR	The 11x14 inch clear film supply magazine is low.	11x14 clear film supply low.	<None>/interact
LOW 11x14 PAPR	The 11x14 inch paper supply magazine is low.	11x14 paper supply low.	<None>/interact
LOW 14x14	The 14x14 inch film supply magazine is	14x14 film supply low.	<None>/interact

Printer Status Info/ Execution Status Info	Description	Message string visible in 'Status Bar'	Other action for UI/ 'camera symbol'
	low.		
LOW 14x14 BLUE	The 14x14 inch blue film supply magazine is low.	14x14 blue film supply low.	<None>/interact
LOW 14x14 CLR	The 14x14 inch clear film supply magazine is low.	14x14 clear film supply low.	<None>/interact
LOW 14x14 PAPER	The 14x14 inch paper supply magazine is low.	14x14 paper supply low.	<None>/interact
LOW 14x17	The 14x17 inch film supply magazine is low.	14x17 film supply low.	<None>/interact
LOW 14x17 BLUE	The 14x17 inch blue film supply magazine is low.	14x17 blue film supply low.	<None>/interact
LOW 14x17 CLR	The 14x17 inch clear film supply magazine is low.	14x17 clear film supply low.	<None>/interact
LOW 14x17 PAPER	The 14x17 inch paper supply magazine is low.	14x17 paper supply low.	<None>/interact
LOW 24x24	The 24x24 inch film supply magazine is low.	24x24 film supply low.	<None>/interact
LOW 24x24 BLUE	The 24x24 inch blue film supply magazine is low.	24x24 blue film supply low.	<None>/interact
LOW 24x24 CLR	The 24x24 inch clear film supply magazine is low.	24x24 clear film supply low.	<None>/interact
LOW 24x24 PAPER	The 24x24 inch paper supply magazine is low.	24x24 paper supply low.	<None>/interact
LOW 24x30	The 24x30 inch film supply magazine is low.	24x30 film supply low.	<None>/interact
LOW 24x30 BLUE	The 24x30 inch blue film supply magazine is low.	24x30 blue film supply low.	<None>/interact
LOW 24x30 CLR	The 24x30 inch clear film supply magazine is low.	24x30 clear film supply low.	<None>/interact
LOW 24x30 PAPER	The 24x30 inch paper supply magazine is low.	24x30 paper supply low.	<None>/interact
LOW A4 PAPER	The A4 paper supply magazine is low.	A4 paper supply low.	<None>/interact
LOW A4 TRANS	The A4 transparency supply magazine is low..	A4 transparency supply low.	<None>/interact
NO RECEIVE MGZ	The film receive magazine is not available.	Film receiver not available.	<None>/interact
NO RIBBON	The ribbon cartridge needs to be replaced.	Replace ribbon cartridge.	<None>/interact
NO SUPPLY MGZ	The film supply magazinespecified for this job is not available.	Film supply not available.	<None>/interact
CHECK PRINTER	The printer is not ready at this time, operator intervention is required to make the printer available.	Check camera.	<None>/interact
CHECK PROC	The processor is not ready at this time, operator intervention is required to make the printer available.	Check processor.	<None>/interact
PRINTER DOWN	The printer is not operating due to some unspecified reason.	Camera down.	<None>/interact
PRINTER INIT	The printer is not ready at this time, it is expected to become available without intervention. For example, it may be in a normal warm-up state.	Camera initializing.	<None>/Idle
PRINTER OFFLINE	The printer has been disabled by an operator or service person.	Camera off-line.	<None>/interact
PROC DOWN	The processor is not operating due to some unspecified reason.	Processor down.	<None>/interact
PROC INIT	The processor is not ready at this time, it is expected to become available without intervention. For example, it may be in a normal warm-up state.	Processor initializing.	<None>/Idle
PROC OVERFLOW FL	Processor chemicals are approaching the overflow full mark.	Processor chemicals near overflow.	<None>/interact
PROC OVERFLOW HI	Processor chemicals have reached the overflow full mark.	Processor chemicals overflow.	<None>/interact
QUEUED	Print job in Queue	--	<None>/Idle
RECEIVER FULL	The film receive magazine is full.	Receiver full.	<None>/interact
REQ MED NOT INST	The requested film, paper, or other media supply magazine is installed in the printer, but may be available with	Install media supply.	<None>/interact

Printer Status Info/ Execution Status Info	Description	Message string visible in 'Status Bar'	Other action for UI/ 'camera symbol'
	operator intervention.		
REQ MED NOT AVAI	The requested film, paper, or other media requested is not available on this printer.	Media supply not available on this camera. Queue stopped. Change camera.	<b>Queue for this camera will be STOPPED/ Queue stopped</b>
RIBBON ERROR	There is an unspecified problem with the print ribbon.	Error with print ribbon.	<None>/interact
SUPPLY EMPTY	The printer is out of film.	Camera out of film.	<None>/interact
SUPPLY LOW	The film supply is low.	Film supply low.	<None>/interact
UNKNOWN	There is an unspecified problem.	Unspecified problem with camera.	<None>/interact

Table 101 Printer Status Information

### A.9.2 Additional Status Information – AGFA printers

*"Printer Status Infos: Additional Agfa printer Status Infos"*

Printer Status Info/ Execution Status Info	Description	Message string visible in 'Status Bar'	Other action for UI/ 'camera symbol'
WARMING UP	Printer is in the warm-up stage. Spooling of print jobs to disk is still possible.	Camera is warming up.	<None>/idle
OFFLINE	OFFLINE Printer is switched off-line. Spooling of print jobs to disk is still possible.	Camera is switched off-line.	<None>/interact
NONE	General printer warning, no specific information is available. Spooling of print jobs to disk is still possible.	--	<None>/idle

Table 102 Printer Status Information - Agfa

### A.9.3 Additional Status Information – Kodak PACS Link (formerly Imation)

*"Printer Status Infos: Additional Kodak infos for PACS Link (formerly Imation Cameras)"*

Printer Status Info/ Execution Status Info	Description	Message string visible in 'Status Bar'	Other action for UI/ 'camera symbol'
SUPPLY MGZ ERR	The supply magazine has an error.	Film supply has an error.	<None>/interact

Table 103 Printer Status Information – Kodak (Imation)

### A.9.4 Additional Status Information – Kodak 190

*"Printer Status Infos: Additional Kodak infos for Kodak 190"*

Printer Status Info/ Execution Status Info	Description	Message string visible in 'Status Bar'	Other action for UI/ 'camera symbol'
PRINTER STOPPED	The printer has stopped.	Camera has stopped.	<None>/interact
FATAL ERROR	Fatal Error.	Fatal Error. Queue stopped.	<b>Queue for this camera will be STOPPED/ Queue stopped</b>

Table 104 Printer Status Information – Kodak 190

**A.9.5 Additional Status Information – Kodak 2180/1120***“Printer Status Infos: Additional Kodak infos for Kodak 2180/1120”*

Printer Status Info/ Execution Status Info	Description	Message string visible in 'Status Bar'	Other action for UI/ 'camera symbol'
PRINTER NOT RDY	Printer not ready.	Camera not ready..	<None>/interact
CHECK PROCESSOR	Check processor.	Check processor.	<None>/interact
NO TONER	No toner.	No toner.	<None>/interact
FATAL	Fatal Error.	Fatal Error. Queue stopped.	<b>Queue for this camera will be STOPPED/ Queue stopped</b>

Table 105 Printer Status Information – Kodak 2180/1120

**A.9.6 Additional Status Information – Codonics**

Printer Status Info/ Execution Status Info	Description	Message string visible in 'Status Bar'	Other action for UI/ 'camera symbol'
STANDARD	Printer is ready.	Camera is ready.	<None>/Normal
LOAD A-SIZE	Load A-Size media.	Load A-Size media.	<None>/interact
LOAD A-DVPAPER	Load A-Size black and white paper.	Load A-Size black and white paper.	<None>/interact
LOAD A-CVPAPER	Load A-Size color paper.	Load A-Size color paper.	<None>/interact
LOAD A-CVTRANS	Load A-Size transparencies.	Load A-Size transparencies.	<None>/interact
LOAD A4-SIZE	Load A4-Size media.	Load A4-Size media.	<None>/interact
LOAD A4-DVPAPER	Load A4-Size black and white paper.	Load A4-Size black and white paper.	<None>/interact
LOAD A4-CVPAPER	Load A4-Size color paper.	Load A4-Size color paper.	<None>/interact
LOAD A4-CVTRANS	Load A4-Size transparencies.	Load A4-Size transparencies.	<None>/interact
LOAD LA-SIZE	Load LA-Size media.	Load LA-Size media.	<None>/interact
LOAD LA-DVPAPER	Load LA-Size black and white paper.	Load LA-Size black and white paper.	<None>/interact
LOAD LA-CVPAPER	Load LA-Size color paper.	Load LA-Size color paper.	<None>/interact
LOAD LA-CVTRANS	Load LA-Size transparencies.	Load LA-Size transparencies.	<None>/interact
LOAD LA4-SIZE	Load LA4-Size media.	Load LA4-Size media.	<None>/interact
LOAD LA4-DVPAPER	Load LA4-Size black and white paper.	Load LA4-Size black and white paper.	<None>/interact
LOAD LA4-CVPAPER	Load LA4-Size color paper.	Load LA4-Size color paper.	<None>/interact
LOAD LA4-CVTRANS	Load LA4-Size transparencies.	Load LA4-Size transparencies.	<None>/interact
LOAD XLA-SIZE	Load XLA-Size media.	Load XLA-Size media.	<None>/interact
LOAD XLA-DVPAPER	Load XLA-Size black and white paper.	Load XLA-Size black and white paper.	<None>/interact
LOAD XLA-CVPAPER	Load XLA-Size color paper.	Load XLA-Size color paper.	<None>/interact
LOAD XLA-CVTRANS	Load XLA-Size transparencies.	Load XLA-Size transparencies.	<None>/interact
LOAD XLA4-SIZE	Load XLA4-Size media.	Load XLA4-Size media.	<None>/interact
LOAD XLA4-DVPAPER	Load XLA4-Size black and white paper.	Load XLA4-Size black and white paper.	<None>/interact
LOAD XLA4-CVPAPER	Load XLA4-Size color paper.	Load XLA4-Size color paper.	<None>/interact
LOAD XLA4-CVTRANS	Load XLA4-Size transparencies.	Load XLA4-Size transparencies.	<None>/interact
LOAD XLW-SIZE	Load XLW-Size media.	Load XLW-Size media.	<None>/interact
LOAD XLW-DVPAPER	Load XLW-Size black and white paper.	Load XLW-Size black and white paper.	<None>/interact

Printer Status Info/ Execution Status Info	Description	Message string visible in 'Status Bar'	Other action for UI/ 'camera symbol'
LOAD XLW-CVPAPER	Load XLW-Size color paper.	Load XLW-Size color paper.	<None>/interact
LOAD 8X10-SIZE	Load 8x10 media.	Load 8x10 media.	<None>/interact
LOAD 8X10-DVFILM	Load XLW-Size black and white film.	Load XLW-Size black and white film.	<None>/interact
SUPPLY MISSING	The film supply magazine specified for this job is not available.	Film supply not available.	<None>/interact
RIBBON MISSING	Ribbon is missing.	Ribbon is missing.	<None>/interact
RIBBON EMPTY	Ribbon is empty.	Ribbon is empty.	<None>/interact
TOP COVER OPEN	Top cover of printer is open.	Top cover of camera is open.	<None>/interact

Table 106 Printer Status Information – Codonics

**A.9.7 Additional DICOM Execution Status Information**

Printer Status Info/ Execution Status Info	Description	Message string visible in 'Status Bar'	Other action for UI/ 'camera symbol'
INVALID PAGE DES	The specified page layout cannot be printed or other page description errors have been detected.	Film Job cannot be printed on this camera. Queue stopped. Please redirect film job.	<b>Queue for this camera will be STOPPED/ Queue stopped</b>
INSUFFICIENT MEMORY	There is not enough memory available to complete this job.	Not enough memory available in camera. Queue stopped. Please continue queue or change camera.	<b>Queue for this camera will be STOPPED/ Queue stopped</b>
NONE	General printer warning, no specific information is available. Spooling of print jobs to disk is still possible.	--	<None>/Idle

Table 107 Additional DICOM Execution Status Infos